

SUPER SHOT™

table tennis table



www.sportcraft.com

TO ORDER PARTS, visit our website.



24971 ZD

MODEL # / no. de modelo / N° de modèle

Assembly and Instructions

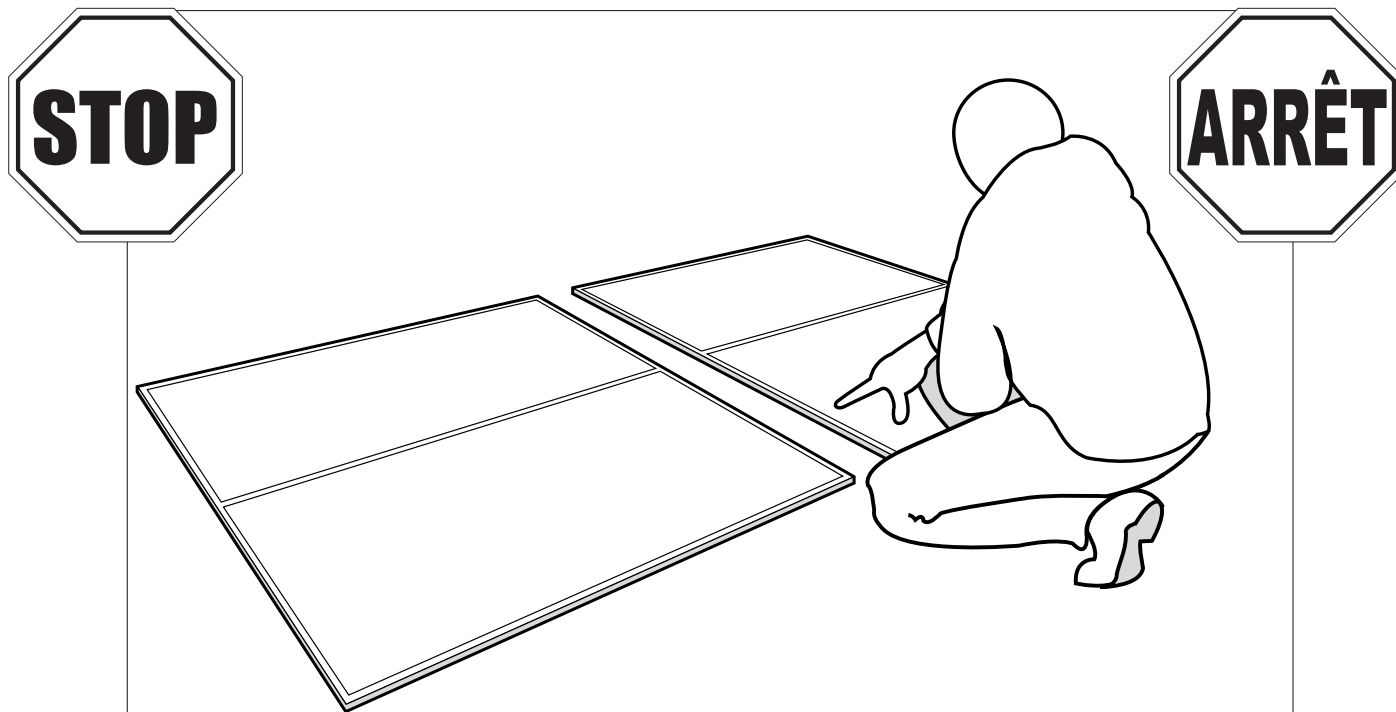

INSPECT YOUR PLAYFIELD BEFORE ASSEMBLY!

- Your playfield/main table frame is **NOT** replaceable and the product will need to be returned to the original place of purchase if damaged. Please make sure to check it before beginning assembly.
- Please make sure you received 1 box(es).

¡INSPECCIONE SU SUPERFICIE DE JUGAR ANTES DE ASAMBLEA!

- Su campo de juego/marco de mesa **NO** es reemplazable e el producto debería ser devuelto a la tienda de ser dañada. Por favor asegúrese para inspeccionarlo antes de la asamblea que comienza.
- Por favor asegúrese que usted recibió 1 caja(s).

INSPECTEZ LA SURFACE DE JEU AVANT D'ASSEMBLER LA TABLE

- La table de billard doit être retournée à l'entrepôt si la surface de jeu est endommagée, car celle-ci ne peut être remplacée. Assurez-vous de l'inspecter attentivement avant de procéder à l'assemblage.
- Veuillez vous assurer d'avoir reçu 2 boîte(s).



CONTACT INFORMATION / INFORMACIÓN DE CONTACTO / NOUS JOINDRE

Hours: Mon.-Fri., 9:00 a.m. to 5:00 p.m. EST
/ Horas: lunes a viernes, 9:00 a.m. a 5:00 p.m. EST / Heures d'ouverture : du lundi au vendredi, de 9 h à 17 h HNE

Replacement Parts: **www.Sportcraft.com / 1-800-526-0244**
/ Piezas de recambio / Pièces de rechange

Technical Support: **1-800-526-0244 / CustomerService@Sportcraft.com**
/ Soporte técnico / Soutien technique

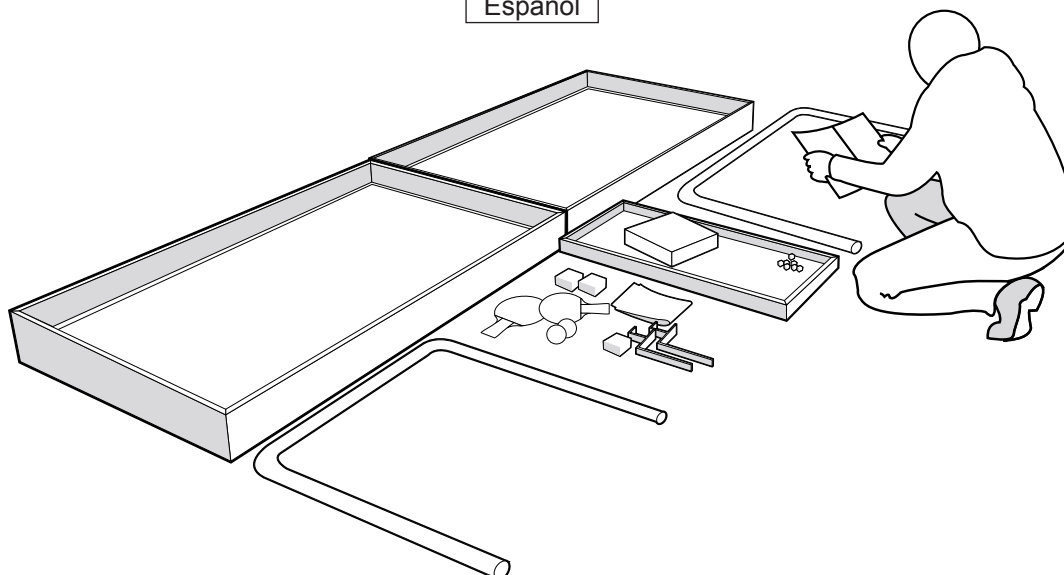
**IMPORTANT!****PLEASE KEEP YOUR INSTRUCTIONS AND RECEIPT/PROOF-OF-PURCHASE!**

- Please review the replacement parts guide and make sure that you have all your parts before beginning assembly.
- For questions that may arise or for missing/damaged parts, PLEASE CONTACT US AT [1-800-526-0244](tel:1-800-526-0244) BEFORE RETURNING THE GAME TO THE STORE.
- Please keep your Proof-of-Purchase (or Store Receipt) with your manual. Your model number and proof-of-purchase will be required for you to receive customer service help and warranty parts service. Please staple below.

¡IMPORTANTE!**¡IMPORTANTE! ¡POR FAVOR GUARDE ESTAS INSTRUCCIONES Y SU RECIBO/PRUEBA-DE-COMPRA!**

- Por favor consultar la guía de piezas de recambio y asegurarse que usted tiene todas sus piezas antes de comenzar la asamblea.
- Para preguntas o para piezas que no se hayan incluidos/dañadas, POR FAVOR PÓNGASE EN CONTACTO CON NOSOTROS AL [1-800-526-0244](tel:1-800-526-0244) ANTES DE DEVOLVER A LA TIENDA.
- Por favor guardar su prueba-de-compra (o su recibo de tienda) con su manual. Su número de modelo y su prueba-de-compra serán requeridos para recibir la ayuda del servicio de consumidor y del servicio para las piezas conforme a la garantía. Por favor graparlo debajo.

IMPORTANT!**CONSERVEZ CES INSTRUCTIONS ET VOTRE REÇU OU PREUVE D'ACHAT**

- Avant de commencer l'assemblage, utilisez le guide des pièces pour vous assurer que vous avez toutes les pièces.
- Si vous avez des questions ou qu'il vous manque des pièces, COMMUNIQUEZ AVEC NOUS EN COMPOSANT LE [1-800-526-0244](tel:1-800-526-0244), AVANT DE RETOURNER L'ARTICLE EN ENTREPÔT.
- Gardez votre preuve d'achat avec le présent guide d'assemblage. Vous aurez besoin de votre preuve d'achat et du numéro de modèle pour avoir droit au service à la clientèle et pour commander des pièces sous garantie. Veuillez agraffer votre preuve d'achat ci-dessous.

STAPLE YOUR RECEIPT HERE –

Proof-of-Purchase is required to order parts under warranty.

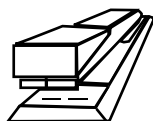
**GRAPA SU RECIBO AQUÍ-**

La prueba-de-compra es requerido para ordenar piezas conforme a la garantía.

AGRAFEZ VOTRE REÇU ICI-

La preuve-d'achat est exigée pour commander des pièces conformes à la garantie.

Do not use or keep product outdoors. For indoor use only. No wet/humid conditions.



No use y no guarde el producto al aire libre. Para el empleo de interior sólo. Ningunas condiciones mojadas/húmedas.



Ne pas utiliser ni laisser le produit à l'extérieur. Pour l'utilisation intérieur seulement. Aucune condition humide.

! WARNING!

This is not a child's toy. Adult supervision is required for children playing this game. Please read instructions carefully. Proper use of this set can prevent damage or injury.

! CHOKING HAZARD -- Product contains small balls and/or small parts. Not for children under 3 years.

! ¡ADVERTENCIA!

Esto no es un juguete de niños. La supervisión adulta es requerida cuando los niños juegan este juego. Por favor leer las instrucciones con cuidado. El empleo apropiado de este juego puede evitar el daño o la herida.

! RIESGO DE ASFIXIA - el producto contiene pequeñas pelotas y/o pequeñas piezas. No es apropiado para niños menores de 3 años.

! MISE EN GARDE

Ceci n'est pas un jouet. La présence d'un adulte est nécessaire lorsque des enfants jouent à ce jeu. Veuillez lire les instructions attentivement. L'utilisation appropriée de ce jeu peut prévenir les dommages matériels et les blessures.

! RISQUE D'ÉTOUFFEMENT - le produit contient des petites balles et de petites pièces. Non recommandé pour des enfants de moins de 3 ans.

ATTENTION

REMOVE NET BEFORE FOLDING TABLE FOR STORAGE POSITION.

Failure to remove net prior to folding for storage may result in Gravity Lock malfunction.

ATENCIÓN

QUITTE LA RED ANTES DE DOBLAR LA MESA EN LA POSICIÓN DE ALMACENAJE.

Fracaso de quitar la red antes de doblar para almacenaje puede causar el mal funcionamiento de la cerradura de gravedad.

ATTENTION

ENLEVEZ LE FILET AVANT DE PLIER LA TABLE DANS LA POSITION DE STOCKAGE.

L'échec d'enlever le filet avant de plier pour le stockage peut aboutir à la défaillance du verrou par gravité.

(Siga a la página siguiente.)

LIMITED WARRANTY

Sportcraft, Ltd. (the "Company") warrants the Product to be free from defects in workmanship and materials under normal use and conditions **FOR A PERIOD OF 90 DAYS FROM THE DATE OF ORIGINAL PURCHASE** in the United States and Canada.

Product Registration Card

The Product Registration Card must be filled out completely and mailed to the Company at the address printed on the card within 10 days from the date of your purchase of the Product.

What Is Covered

Except as provided below, this Limited Warranty covers all defects in materials and workmanship. This Limited Warranty is void if the Product is:

- Damaged through improper usage, negligence, misuse, abuse, transportation damage, acts of nature, or accident (including failure to follow the instructions supplied with the Product)
- Used in commercial applications or rentals
- Modified or repaired by anyone not authorized by the Company.

What Is Not Covered

This Limited Warranty does not cover:

- Any expendable items such as batteries, light bulbs, fuses, accessories, cosmetic parts, tools and other items that wear out due to normal usage.
- Any costs you may incur for delivery, installation, assembly or transport of your product.

What The Company Will Pay For

If during the Limited Warranty period, any part or component of the Product is found by the Company to be defective, the Company will, at its option, repair the Product, replace the Product with a new Product (either the same or an equivalent model) or cause the original retailer of the Product to exchange the Product with a new Product (either the same or an equivalent model) or refund the original purchase price of the Product, without charge for labor or parts. The Company's obligation to repair, replace or exchange the Product, however, shall be limited to the amount of the original purchase price of the Product.

How To Obtain Warranty Service

In order to enforce your rights under this Limited Warranty, you must follow these procedures:

- You must have completed and mailed the Product Registration Card to the Company within 10 days of purchase of the Product.
- You must include **THE ORIGINAL COPY OF YOUR SALES RECEIPT**.
- You must call the Company's Consumer Service Department at 1-800-526-0244 from 9:00 a.m. to 5:00 p.m. (EST) to notify the Company of the nature of the problem.
- If you are instructed to return the Product to the Company for servicing, you are responsible for shipping the Product, at your expense, to the address designated by the Company in packaging that will protect against further damage.
- You must also include your name, address, daytime telephone number, model number of the Product and a description of the problem.

THIS LIMITED WARRANTY IS AVAILABLE ONLY TO THE ORIGINAL PURCHASER OF THE PRODUCT AND IS VALID IN THE UNITED STATES AND CANADA ONLY.

THE COMPANY'S LIABILITY IS LIMITED TO THE REPAIR OR REPLACEMENT, AT ITS OPTION, OF ANY DEFECTIVE PRODUCT AND SHALL NOT INCLUDE ANY LIABILITY FOR INDIRECT, INCIDENTAL OR CONSEQUENTIAL DAMAGES OF ANY KIND.

THIS WARRANTY IS EXPRESSLY MADE IN LIEU OF ALL OTHER WARRANTIES, EXPRESSED OR IMPLIED.

SOME STATES DO NOT ALLOW LIMITATIONS ON HOW LONG AN IMPLIED WARRANTY LASTS OR DO NOT ALLOW FOR EXCLUSION OF INCIDENTAL OR CONSEQUENTIAL DAMAGES. TO THAT EXTENT, THE ABOVE LIMITATIONS MAY NOT APPLY TO YOU.

This Limited Warranty gives you specific legal rights, but you may also have other rights that vary from state to state.

If you have questions regarding this Limited Warranty or the operation of the Product, you may call or write us:

Consumer Service Department
313 Waterloo Valley Rd.
Budd Lake, NJ 07498
1-800-526-0244
www.sportcraft.com

0510 TG

GARANTIA LIMITADA

Sportcraft, Ltd. (la "Compañía") garantiza que este producto no tiene defectos de fabricación ni materiales bajo condiciones y uso normales **POR UN PERIODO DE 90 DÍAS A PARTIR DE LA FECHA DE COMPRA ORIGINAL**, en Estados Unidos y Canadá.

Tarjeta de registro del producto

La tarjeta de registro del producto se debe llenar por completo y enviar por correo a la Compañía a la dirección impreso sobre la tarjeta dentro de 10 días a partir de la fecha de compra del Producto.

La cobertura

Esta garantía cubre todos los defectos de fabricación y materiales, excepto lo que se indica a continuación. Esta garantía limitada no tiene validez si el producto:

- Se daña por uso inapropiado, negligencia, mal uso, abuso, daño de transporte, fenómenos naturales o accidentes (incluyendo el no seguir las instrucciones que se proporcionan con el producto).
- Se usa en aplicaciones comerciales o se alquila
- Alguna persona no autorizada por la Compañía lo modifica o repara.

Lo que la garantía no cubre

La garantía limitada no cubre:

- Ningún artículo perecedero tales como baterías, focos, fusibles, accesorios, partes cosméticas, herramientas, y otros artículos que se gastan con el uso normal.
- Ningún gasto que se puede incurrir para la entrega, la instalación, la asamblea o el transporte de su producto.

Pagos de la Compañía

Si durante el periodo de la Garantía Limitada, la Compañía determina que alguna pieza o componente del producto tiene defectos, a su discreción, lo reparará o reemplazará el Producto con un nuevo Producto (ya sea con un modelo similar o equivalente) o causa la tienda original del Producto para cambiar el Producto con un Producto nuevo (sea con un modelo similar o equivalente) o reembolsa el precio de compra original del Producto, sin cargos por la mano de obra o las piezas. La obligación de la Compañía de reparar, sustituir, o reemplazar el Producto, sin embargo, será limitada con el precio de compra original del Producto.

Cómo obtener servicios de garantía

Para hacer cumplir sus derechos de esta Garantía Limitada, debe seguir estos procedimientos:

- Debe haber completado y ha enviado la tarjeta de registro de Producto a la Compañía dentro de 10 días de compra del Producto.
- Debe incluir LA COPIA ORIGINAL DE SU RECIBO DE LAS VENTAS.
- Debe llamar al departamento de Servicio al Cliente de la Compañía al 1-800-526-0244 entre las 9:00 a.m. y 5:00 p.m. (hora del este) para notificar a la Compañía la naturaleza del problema.
- Si está instruido a devolver el Producto a la Compañía para la manutención, está responsable para el envío del Producto, a su gusto, a la Compañía a la dirección situada debajo, en un embalaje que protegerá contra el remoto daño.
- Asimismo, debe incluir su nombre, dirección, número de teléfono durante el día, el modelo del producto y una descripción del problema.

ESTA GARANTÍA LIMITADA ES DISPONIBLE SÓLO AL COMPRADOR ORIGINAL DEL PRODUCTO Y ES VÁLIDA SOLAMENTE EN ESTADOS UNIDOS Y CANADÁ.

LA RESPONSABILIDAD DE LA COMPAÑÍA SE LIMITA A REPARAR O REEMPLAZAR, A SU DISCRECIÓN, CUALQUIER PRODUCTO DEFECTUOSO Y NO INCLUIRÁ RESPONSABILIDAD POR DAÑOS INDIRECTOS, INCIDENTALES O CONSECUENTES DE NINGUNA CLASE.

ESTA GARANTÍA OTORGADA SUPERSEDE A CUALQUIER OTRA GARANTÍA, EXPRESO O IMPLÍCITO.

ALGUNOS ESTADOS NO PERMITEN LIMITACIONES EN LA DURACIÓN DE GARANTÍAS IMPLÍCITAS O NO PERMITEN LA EXCLUSIÓN DE DAÑOS CONSECUENTES O INCIDENTALES. EN ESE CASO, LAS LIMITACIONES MENCIONADAS ARRIBA NO SE APLICAN A USTED.

Esta garantía limitada le otorga derechos legales específicos, pero usted también tiene otros derechos que varían de un estado a otro.

Si tiene alguna pregunta con respecto a esta Garantía Limitada o la operación del producto, usted puede llamar o escribir a:

Consumer Service Department
313 Waterloo Valley Rd.
Budd Lake, NJ 07498
1-800-526-0244
www.sportcraft.com

0510 TG

GARANTIE LIMITÉE

Sportcraft Ltd. (la « société ») garantit cet article contre tout défaut de fabrication et de matériel **PENDANT 90 JOURS À PARTIR DE LA DATE D'ACHAT**, pourvu qu'il ait été utilisé normalement. La garantie est valide aux États-Unis et au Canada.

Carte d'enregistrement

L'acheteur doit s'assurer de remplir la carte d'enregistrement et de la poster à la compagnie, à l'adresse imprimée sur la carte, dans les 10 jours suivant la date d'achat.

Ce qui est couvert

La garantie limitée couvre tous les défauts de matériel et de fabrication, mais ne couvre pas les dommages :

- dus à un usage abusif, incorrect ou négligent, à un accident ou au transport, ni les dommages causés par le non-respect des instructions fournies avec l'article;
- si le jeu est loué ou utilisé à des fins commerciales;
- si le jeu est modifié ou réparé par une personne non autorisée par la société.

Ce qui n'est pas couvert

Cette garantie limitée ne couvre pas :

- les produits de consommation comme les piles, les ampoules et les fusibles, les accessoires, les pièces cosmétiques, les outils ni aucun autre composant qui est sujet à l'usure normale;
- les frais engagés pour la livraison, l'installation, l'assemblage ou le transport de l'article.

Frais assumés par la société

Si au cours de la période de garantie limitée, la société juge qu'une pièce ou un composant du produit est défectueux, elle s'engage à réparer l'article ou à le remplacer par un nouvel article (soit du même modèle ou d'un modèle équivalent). Elle peut aussi exiger du détaillant qu'il échange l'article défectueux avec un nouvel article (soit du même modèle ou d'un modèle équivalent) ou qu'il rembourse le prix d'achat de l'article, sans aucun frais de main-d'œuvre ou de pièces. Toutefois, la responsabilité de la société de réparer, de remplacer ou d'échanger le produit se limite au prix d'achat du produit.

Réclamation sous garantie

Voici comment vous devez procéder pour avoir droit aux privilèges de la présente garantie :

- vous êtes tenu de remplir la carte d'enregistrement de l'article et la poster à la société dans les 10 jours suivant l'achat;
- vous devez inclure LE REÇU DE CAISSE D'ORIGINE;
- vous devez communiquer avec le service à la clientèle en composant le 1-800-526-0244 (en anglais seulement), de 9 h à 17 h (HE) pour aviser la société de la nature du problème et pour obtenir des instructions sur la façon de procéder;
- si la société vous demande de retourner l'article à un endroit spécifique pour le faire réparer, vous êtes responsable d'expédier l'article à vos frais, à l'adresse indiquée. Vous devez emballer le produit de sorte qu'il ne subisse aucun dommage durant le transport;
- vous devez également donner votre nom, votre adresse, votre numéro de téléphone (durant le jour), le numéro de modèle de l'article et une description du problème.

CETTE GARANTIE LIMITÉE N'EST OFFERTE QU'À L'ACHETEUR INITIAL ET N'EST VALIDE QU'AUX ÉTATS-UNIS ET AU CANADA.

LA RESPONSABILITÉ DE LA SOCIÉTÉ SE LIMITE À LA RÉPARATION OU AU REMPLACEMENT (À SA DISCRÉTION) DE TOUT ARTICLE DÉFECTUEUX. LA SOCIÉTÉ NE PEUT ÊTRE TENUE RESPONSABLE D'AUCUN DOMMAGE INDIRECT OU ACCESSOIRE.

CETTE GARANTIE REMPLACE EXPRESSÉMENT TOUTE AUTRE GARANTIE, FORMELLE OU IMPLICITE.

COMME CERTAINES PROVINCES OU CERTAINS ÉTATS NE PERMETTENT PAS LA LIMITE DE LA DURÉE DES GARANTIES IMPLIQUES NI L'EXCLUSION DES DOMMAGES INDIRECTS OU ACCESSOIRES, IL SE PEUT QUE LES RESTRICTIONS SUSMENTIONNÉES NE S'APPLIQUENT PAS À VOUS.

La présente garantie vous donne des droits spécifiques, et il se peut aussi que vous ayez d'autres droits selon la province ou l'état où vous demeurez.

Si vous avez des questions concernant la garantie ou le fonctionnement de l'article, vous pouvez nous appeler ou nous écrire à :

Consumer Service Department
313 Waterloo Valley Rd.
Budd Lake, NJ 07498
1-800-526-0244
www.sportcraft.com

0510 TG-CA

TOOLS REQUIRED / HERRAMIENTAS NECESARIAS / OUTILS REQUIS



Do Not Use Drill
No use el taladro
Ne pas utiliser de perceuse



Phillips Screwdriver (included)
Destornillador Phillips (incluido)
Tournevis à pointe cruciforme (compris)

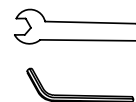

Wrenches (included)
Llaves (incluidas)
Clés (comprises)

PARTS GUIDE / GUÍA DE PIEZAS / GUIDE DES PIÈCES

For replacement, missing or defective parts, order online or call:

Para las piezas de recambio, que faltan o defectuosas, ordenar a la página web o pongase en contacto:

Pour obtenir des pièces de rechange, commandez en ligne ou composez le numéro sans frais :

www.sportcraft.com

1-800-526-0244

Example Consumer-Install Part /

Pieza de ejemplo instalada por el consumidor /
Exemple de pièce à installer par le consommateur

 ID # / No. de secuencia / N° du schéma	(X 4)	CASTER WITH LOCK RUEDECILLA CON CARRADURA ROULETTE BLOCABLE 24922GD32	← = No Shading / Ningún color / Fond blanc
	Quantity / Cantidad / Quantité	← Part Number / No. de pieza / N° de pièce	

Example Pre-Installed Part /

Pieza de ejemplo preinstalada /
Exemple de pièce préinstallée

 ID # / No. de secuencia / N° du schéma	(X 1)	SAFETY STRAP WITH BUCKLE CORREA DE SEGURIDAD CON HEBILLA COURROIE AVEC BOUCLE 24922GD38	← = Shading / color / Fond ombragé
	Quantity / Cantidad / Quantité	← Part Number / No. de pieza / N° de pièce	

TABLE & LEG COMPONENTS / COMPONENTES DE MESA Y PIERNA / COMPOSANTS DE LA TABLE ET DES PIEDS

1 (X 1)	PLAYFIELD - 2 PC - A - HALF ONLY - W/ STRAP AND BUCKLE NON-REPLACEABLE	2 (X 1)	PLAYFIELD - 2 PC - B - HALF ONLY - W/BUCKLE NON-REPLACEABLE
3 (X 2)	TUBE - LINKAGE - W/O STOP BRACKET 24971ZD03	4 (X 2)	TUBE - LINKAGE - W/ STOP BRACKET 24971ZD04

(Siga a la página siguiente.)

REPLACEMENT PARTS / PIEZAS DE RECAMBIO /
PIÈCES DE RECHANGE www.sportcraft.com

Shaded box = pre-installed part / Caja coloreada = pieza preinstalada / Fond ombragé = pièce préinstallée

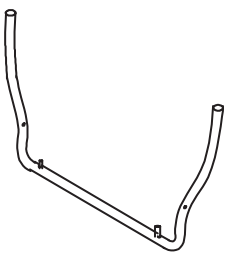
5		LEG - CURVED - OUTER - W/ CAPS & PIN
		(X 2) 24971ZD05

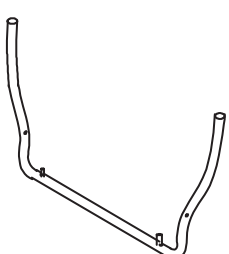
6		LEG - CURVED INNER - W/ CASTER INSERTS AND PIN
		(X 2) 24971ZD06

7		SPREADER - WELDED - W/ MOLDED LOGO
		(X 2) 24971ZD07

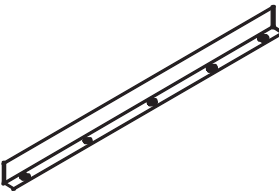
8		APRON - SIDE - WELDED
		(X 4) 24971ZD08

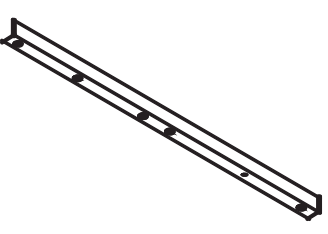
9		APRON - END - WELDED
		(X 2) 24971ZD09

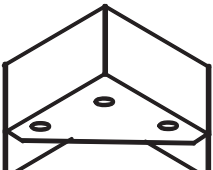
10		CAP - CORNER - MOLDED - BLACK
		(X 4) 24971ZD10

11		CASTER - W/ LOCK
		(X 4) 24971ZD11

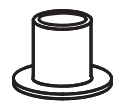
12		CAP - INNER - LEG - W/ CASTER INSERT
		(X 4) 24971ZD12

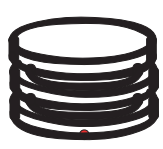
13		CAP - OUTER - LEG - W/O CASTER INSERT
		(X 4) 24971ZD13

(Siga a la página siguiente.)

REPLACEMENT PARTS / PIEZAS DE RECAMBIO /
PIÈCES DE RECHANGE www.sportcraft.com

 Shaded box = pre-installed part / Caja coloreada = pieza preinstalada / Fond ombragé = pièce préinstallée

SMALL PRODUCT PARTS / PEQUEÑAS PIEZAS DE PRODUCTO / PETITES PIÈCES

20		LOCK - GRAVITY
		(X 2) 24971ZD16

21		SAFETY STRAP - MALE - W/O BUCKLE
		(X 1) 24971ZD17

22		SAFETY STRAP - FEMALE - W/ BUCKLE
		(X 2) 24971ZD18

ELECTRONIC SCORER COMPONENTS / ELECTRONIC SCORER COMPONENTS / COMPOSANTS DE MARQUEUR ÉLECTRONIQUE

23		SCORER - LED DISPLAY - HOME W/ WIRE
		(X 1) 24971HX37

24		SCORER - LED DISPLAY - VISITOR W/ WIRE
		(X 1) 24971HX38

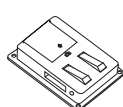
25		SCORER - CONTROL BOX
		(X 1) 24971HX39

ACCESSORIES & MAINTENANCE / ACCESORIOS Y MANTENIMIENTO / ACCESSOIRES ET PIÈCES D'ENTRETIEN

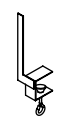
27		POST - TABLE TENNIS
		(X 2) 24971ZD19

28		NET - TABLE TENNIS
		(X 1) 24971ZD20

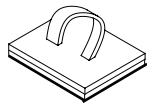
29		TAPE - DOUBLE SIDED
		(X 4) 24971HX21

HARDWARE & TOOLS / FERRETERÍA Y HERRAMIENTA / QUINCAILLERIE ET OUTILS

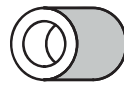
35		BUSHING - 8 MM
		(X 6) 24971ZD23









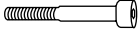

36		SCREW - ROUND HEAD - 4 X 14 MM
		(+83 PRE-INSTALLED)
		(X 24) 24971ZD24

37		WASHER - 6 MM (+8 PRE-INSTALLED)
		(X 30) 24971ZD25

(Siga a la página siguiente.)

REPLACEMENT PARTS / PIEZAS DE RECAMBIO /
PIÈCES DE RECHANGE www.sportcraft.com

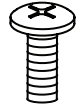
Shaded box = pre-installed part / Caja coloreada = pieza preinstalada / Fond ombragé = pièce préinstallée

<p>38</p>  <p>(X 16)</p>	<p>BOLT - ALLEN KEY (5 MM) - 6 X 60 MM</p> <p>24971ZD26</p>	<p>39</p>  <p>(X 12)</p>	<p>SCREW - HEX HEAD - 5 X 15 MM</p> <p>24971ZD27</p>	<p>40</p>  <p>(X 1)</p>	<p>WRENCH - HEX METAL - 6 MM & 10 MM</p> <p>24971ZD28</p>
<p>41</p>  <p>(X 10)</p>	<p>NUT - LOCK W/ WASHER - 6 MM (+10 PRE-INSTALLED)</p> <p>24971ZD29</p>	<p>42</p>  <p>(X 4)</p>	<p>BRACKET - SINGLE METAL (+8 PRE-INSTALLED)</p> <p>24971ZD30</p>	<p>43</p>  <p>(X 1)</p>	<p>SCREWDRIVER - PHILLIPS HEAD - MINI</p> <p>24971ZD31</p>
<p>44</p>  <p>(X 8)</p>	<p>BOLT - ROUND HEAD - 6 X 30 MM</p> <p>24971ZD32</p>	<p>45</p>  <p>(X 1)</p>	<p>WRENCH - ALLEN KEY - 5 MM</p> <p>24971ZD33</p>	<p>46</p>  <p>(X 1)</p>	<p>BOLT - ROUND HEAD - 2.3 X 6 MM</p> <p>24971HX36</p>
<p>47</p>  <p>(X 4)</p>	<p>SCREW - WASHER HEAD - 3.5 X 12 MM</p> <p>24971HX35</p>				

NOTE: a printed instruction manual, hardware blister pack and additional accessories may be ordered at: www.sportcraft.com.

NOTA: Ud. puede pedir un manual de instrucciones impreso, el paquete de plástico de ferretería y accesorios adicionales al: www.sportcraft.com.

REMARQUE : Le livret d'instruction imprimé, le sac de quincaillerie ainsi que des accessoires peuvent être commandés sur le site www.sportcraft.com.

(Siga a la página siguiente.)



Strong Adults Needed: 4
Adultos fuertes necesarios
Adultes forts requis



No Children in Assembly Area
Ningunos niños en el área de asamblea
Pas d'enfants dans la zone d'assemblage



No Pets in Assembly Area
Ningunas mascotas en el área de asamblea
Pas d'animaux domestiques dans la zone d'assemblage

English	Español	Français
<p><u>ASSEMBLY INSTRUCTIONS:</u></p> <p>We recommend that adults work together to assemble this table.</p> <ul style="list-style-type: none"> • <i>The table will be assembled upside down and then turned over onto its legs. This is a very heavy table and turning it over will require strong adults.</i> • <i>We suggest that you use the bottom carton as a clean flat work area to protect the table.</i> 	<p><u>INSTRUCCIONES DE ENSAMBLAJE</u></p> <p>Recomendamos que adultos ayuden a armar esta mesa.</p> <ul style="list-style-type: none"> • <i>La mesa puede armarse de manera invertida y después darse vuelta para que se asiente sobre las piernas. Esta mesa es pesado y para darle vuelta será necesaria la participación de adultos fuertes.</i> • <i>Sugerimos que utilice el fondo de la caja como área de trabajo limpia y plana para la protección de la mesa.</i> 	<p><u>INSTRUCTIONS D'ASSEMBLAGE</u></p> <p>Nous recommandons que des adultes procèdent à l'assemblage de cette table.</p> <ul style="list-style-type: none"> • <i>Cette table doit être assemblée à l'envers, puis retournée sur ses pieds. Étant très lourde, il faudra des adultes forts pour retourner la table à l'endroit.</i> • <i>Nous recommandons d'utiliser le carton du fond comme surface de travail propre et plate afin de protéger la table.</i>

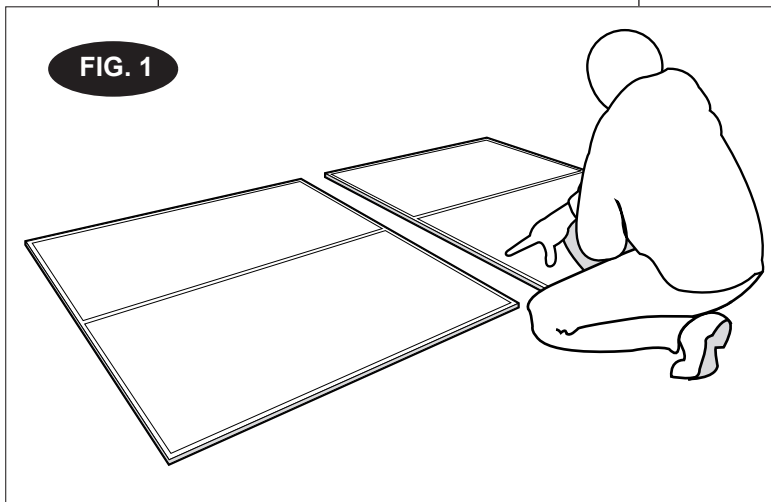

STEP 1:

- Your playfield/main table frame is NOT replaceable and the product will need to be returned to the original place of purchase if damaged. Please make sure to check it before beginning assembly.

PASO 1:

- Su campo de juego/marco de mesa no es reemplazable e el producto debe ser devuelto a la tienda de ser dañada. Por favor asegúrese para inspeccionarlo antes de la asamblea que comienza.

ÉTAPE 1

- La table de billard doit être retournée à l'entrepôt si la surface de jeu est endommagée, car celle-ci ne peut être remplacée. Assurez-vous de l'inspecter attentivement avant de procéder à l'assemblage.

(Siga a la página siguiente.)

English

STEP 2



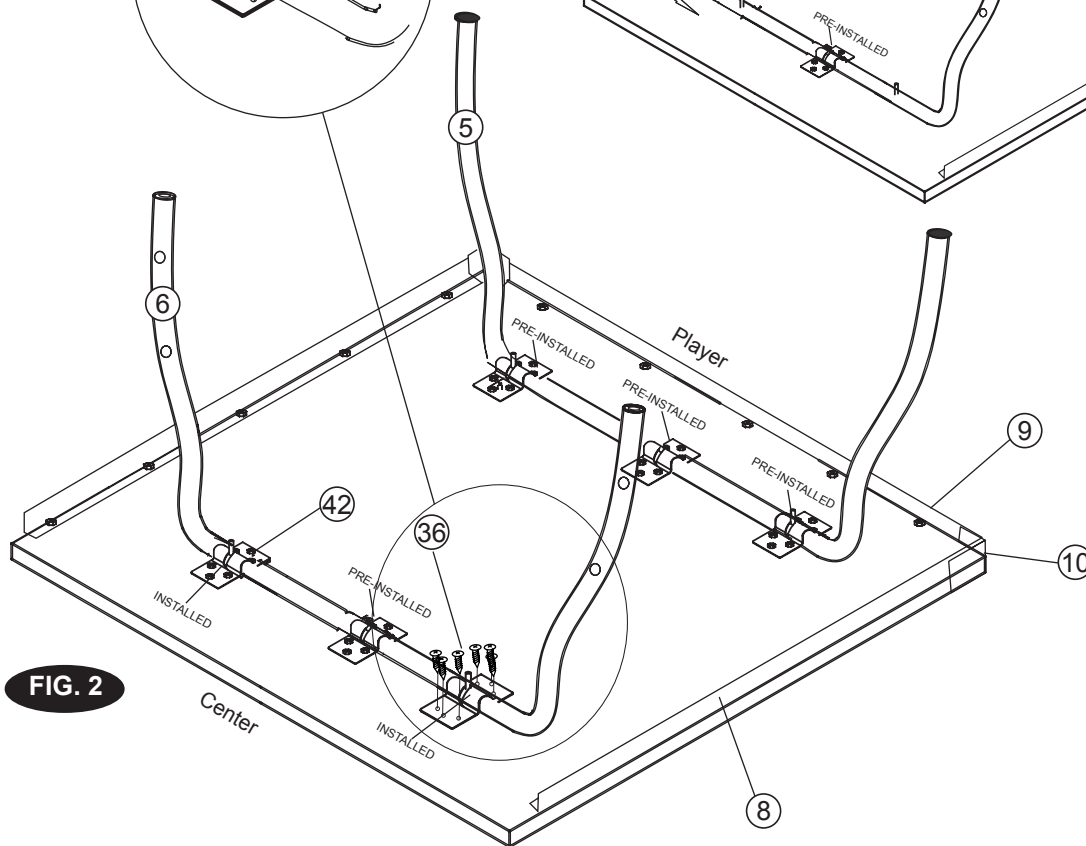
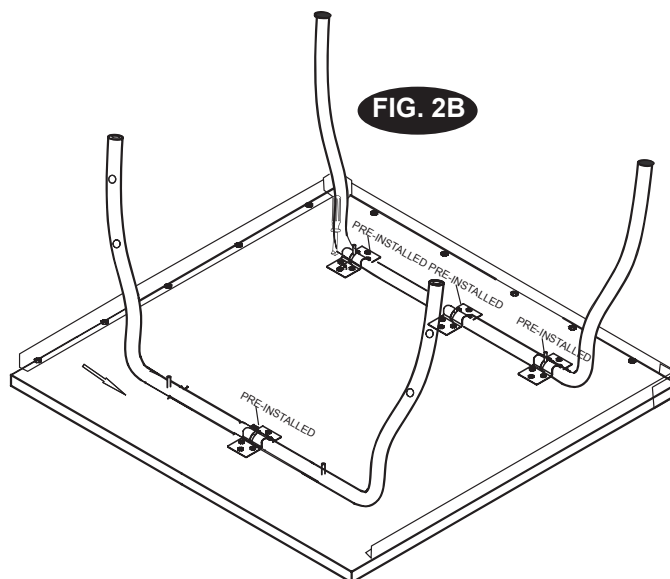
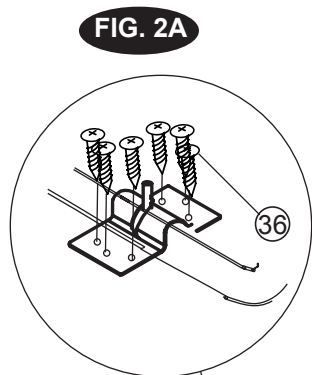
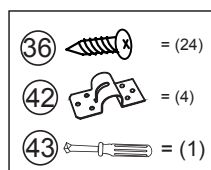





- Make sure the Pre-Installed Metal Brackets (#42) are attached over the Curved Inner Leg (#6) and the Curved Outer Leg (#5).
- Attach two Single Metal Brackets (#42) over the ends of the Curved Inner Leg (#6) using six Screws (#36) per bracket. See Fig. 2 and 2A. **NOTE:** Make sure the slots in the brackets are facing the center.
- Repeat the above steps for the other table half.



English

STEP 3:

- Attach one end of the Linkage Tube (#3) to the inside of the Curved Outer Leg (#5) and the other end of the Linkage Tube to the outside of the Curved Inner Leg (#6) using one Bolt (#38), two Washers (#37), one Bushing (#35), and one Nut (#41) in the order shown in Fig. 3.
- Attach one end of the Linkage Tube with Stop Bracket (#4) to the inside of the Curved Outer Leg (#5) using one Bolt (#38), two Washers (#37), one Bushing (#35) and one Nut (#41).
- Attach the other end of the Linkage Tube with Stop Bracket (#4) to the outside of the Curved Inner Leg (#6) using one Bolt (#38), three Washers (#37) and one Nut (#41). **NOTE:** Do not use a Bushing when attaching the Linkage Tube with Stop Bracket (#4). See Fig. 3.
- Repeat the above steps for the other table half.

③		= (2)	④		= (2)	③⑤		= (6)	③⑧		= (8)
④①		= (8)	③⑦		= (18)	④①		= (1)	④⑤		= (1)

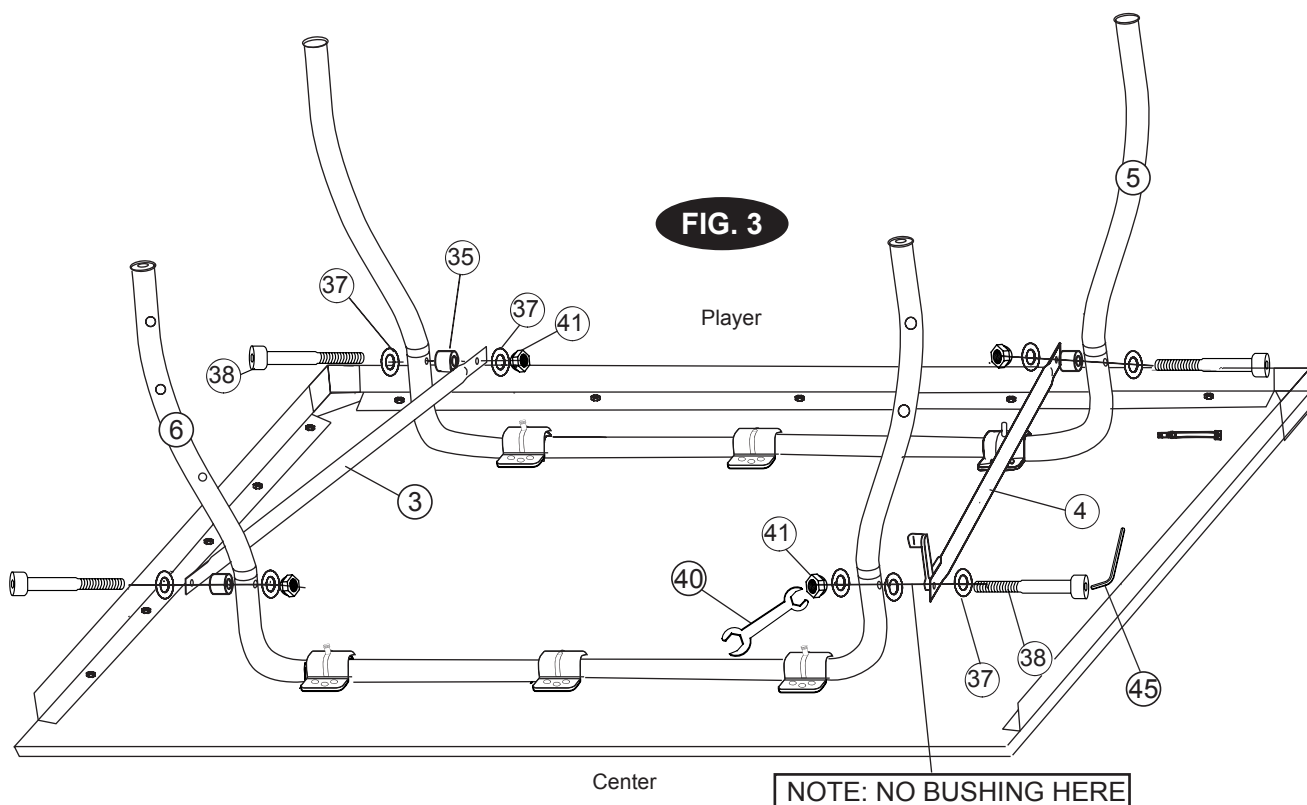

English

STEP 4:

- Make sure that the Inner Leg Caster Caps (#12) are installed into the ends of the Inner Leg with Caster Inserts (#6). Place one Caster with Lock (#11) into each Inner Leg. Lock Casters. See Fig. 4.
- Make sure that the Outer Leg Caps (#13) are installed into the ends of the Curved Outer Leg (#5) as shown in Fig. 4.
- With the logo upside-down, attach one Molded Spreader with Logo (#7) to the Curved Inner Leg (#6) of the two table halves using four Bolts (#38) and four Washers (#37). See Fig. 4 and 4A.
- Repeat the above steps for the other side.

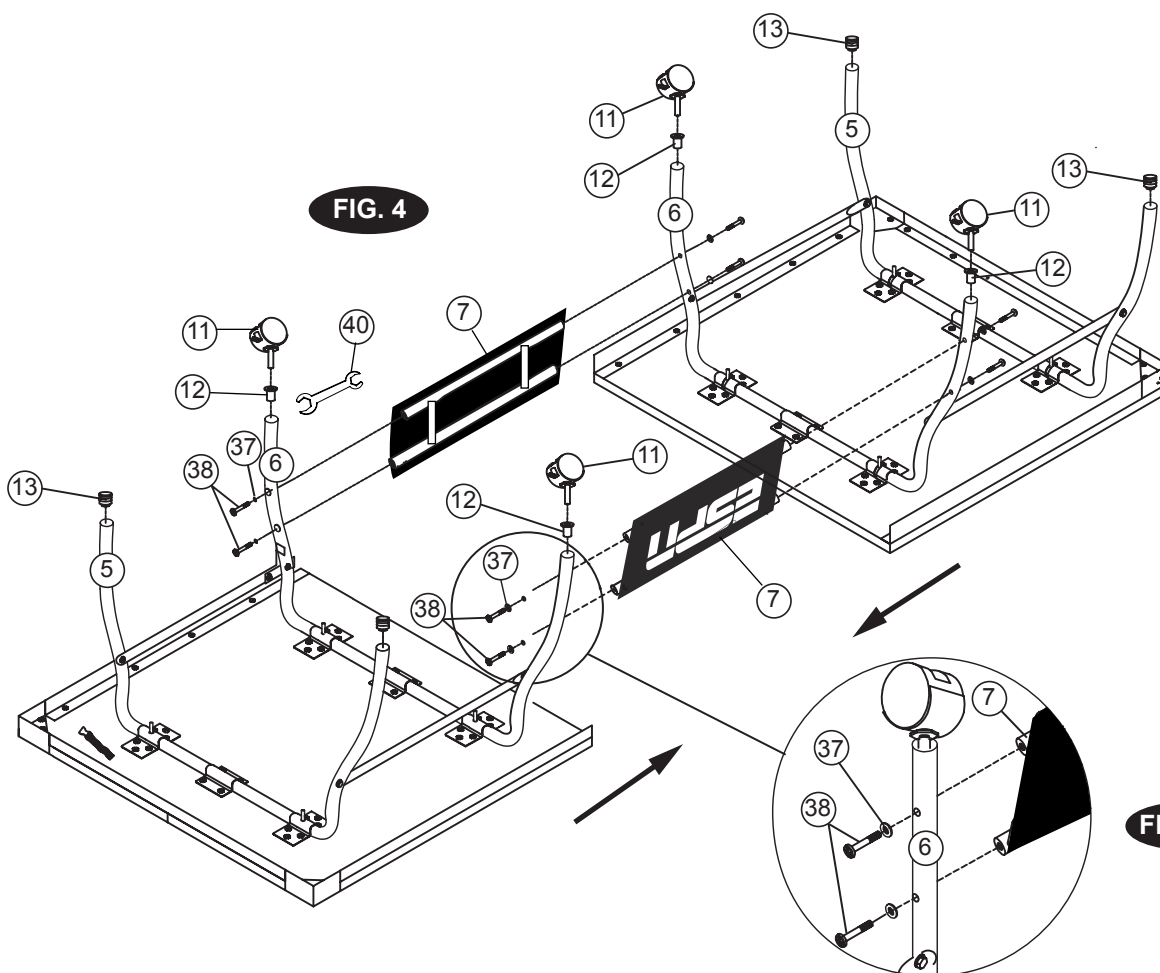
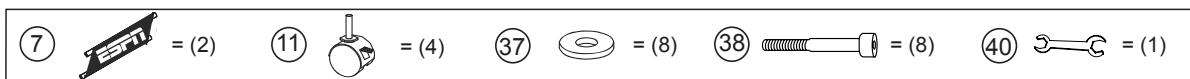

English

STEP 5:

- The frame is connected.
- **Three or more adults are required to turn this table over.**
- **NOTE:** Check that the Casters are locked from Step 4.
- Lift the table onto its side edge. Make sure one person is at each corner while one supports the center. See Fig. 5 and 5A.

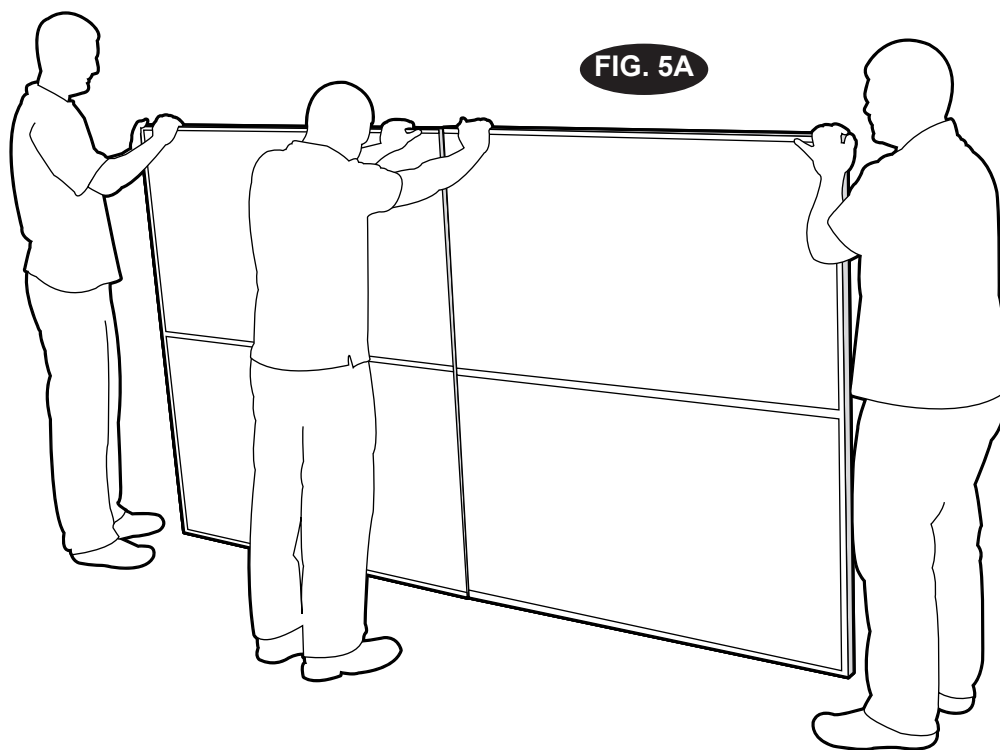
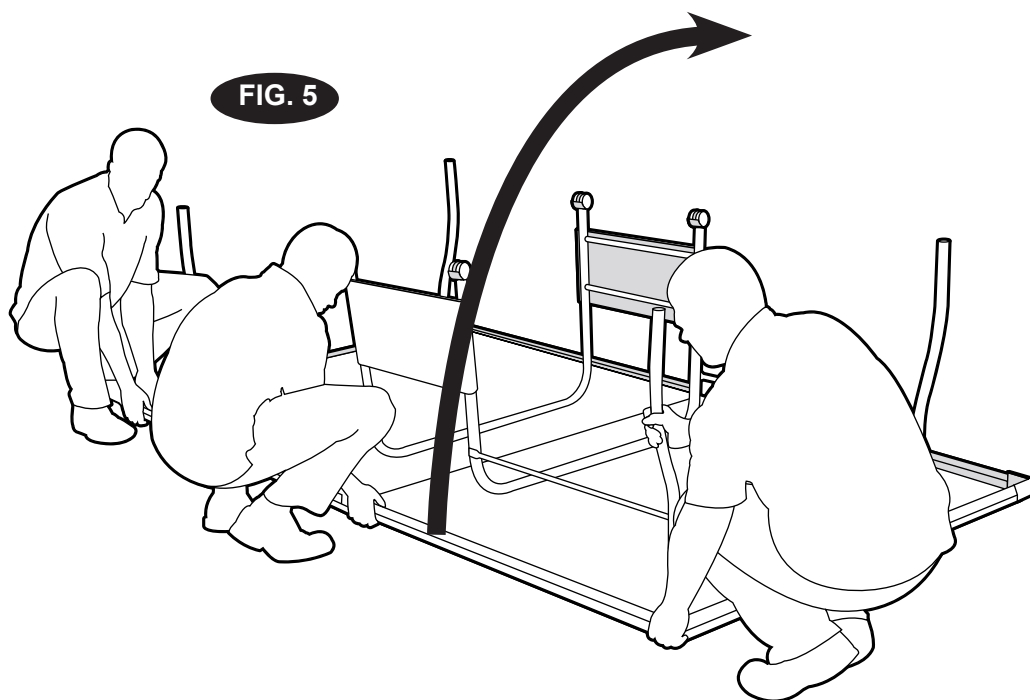

English

STEP 6:

- Fold the table halves together so the blue surfaces face each other. See Fig. 6 and 6A.
- While the table is supported, buckle the red safety strap around the table halves. See Fig. 6A.

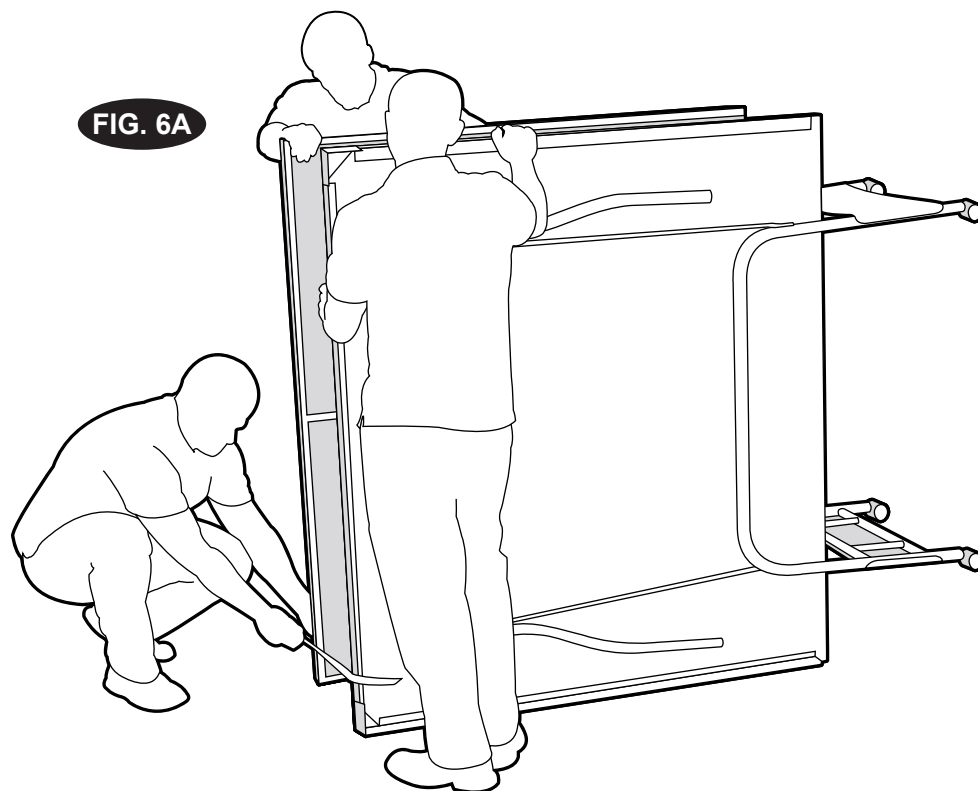
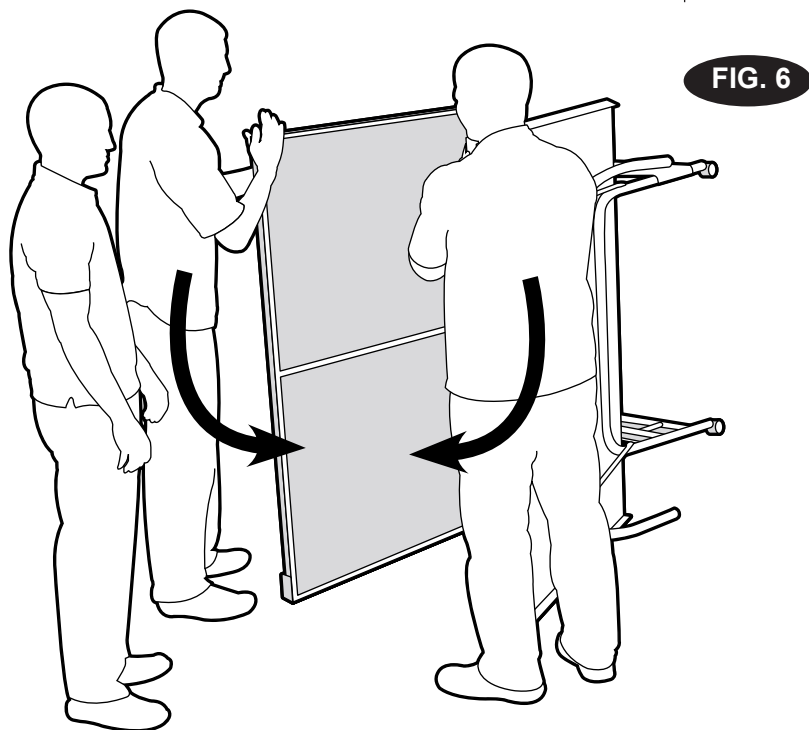

English

STEP 7:

- Using two adults, carefully lift the table halves so the Casters move towards the floor. The third person should support the opposite side of the table.
- Continue moving the table so the casters are placed on the floor. See Fig. 7A and 7B.
- Unbuckle the safety strap and unfold the table into play position.

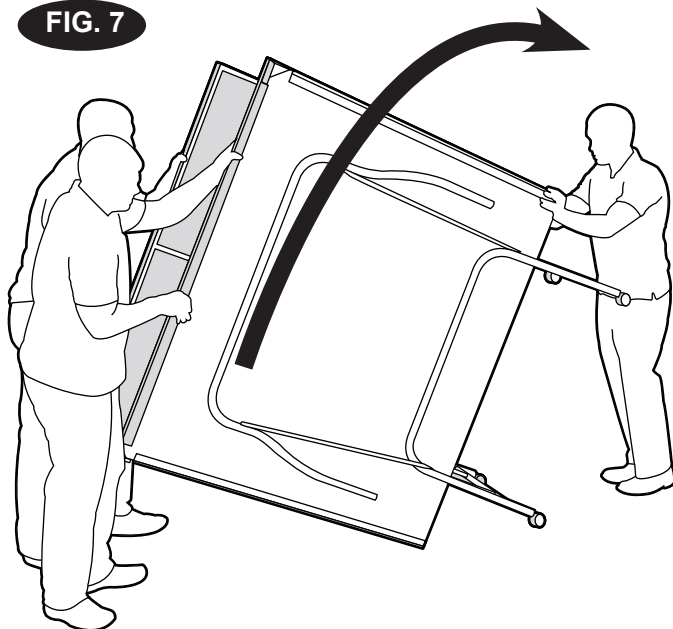
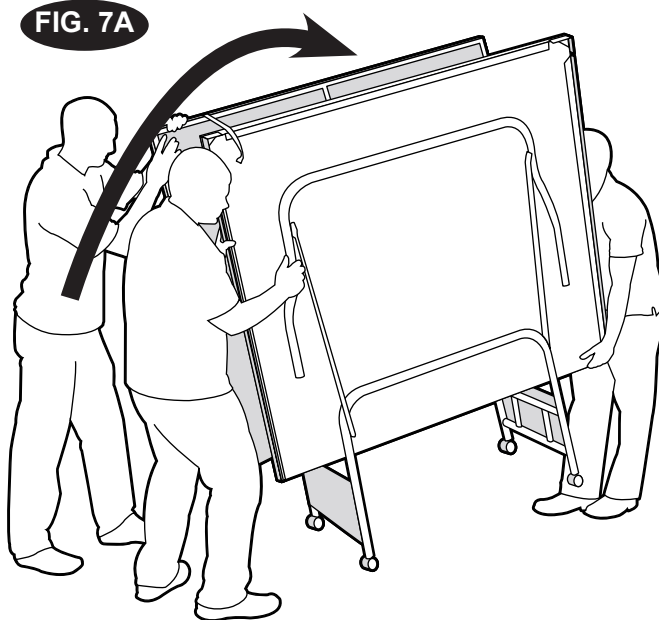
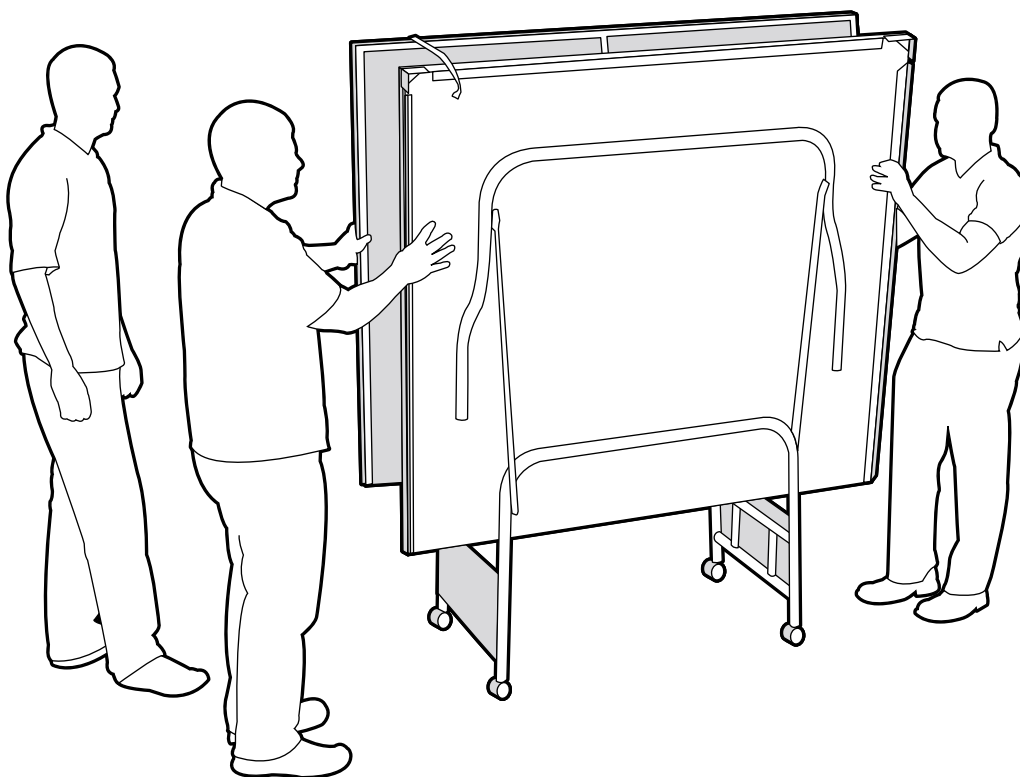
FIG. 7**FIG. 7A****FIG. 7B**

English

STEP 8:

- Attach the Gravity Lock (#20) to the Curved Inner Leg (#6) using two Washers (#37) and one Locking Nut (#41). See Fig. 8 and 8A.
- Repeat the above steps for the other Gravity Lock.

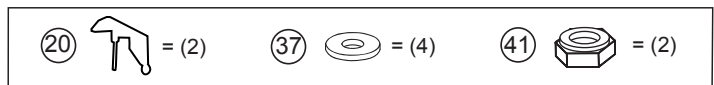

FIG. 8

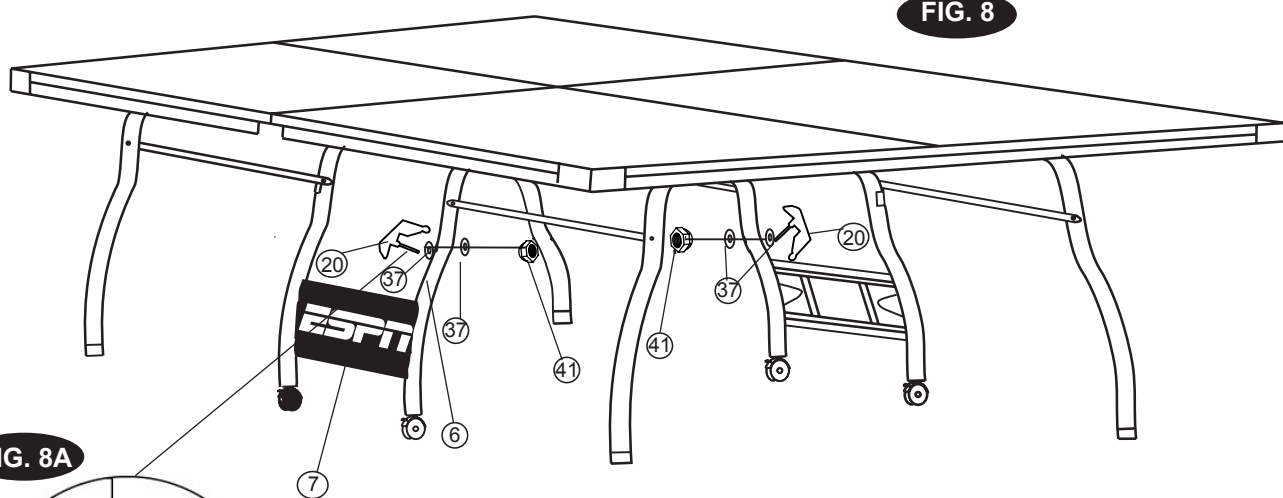
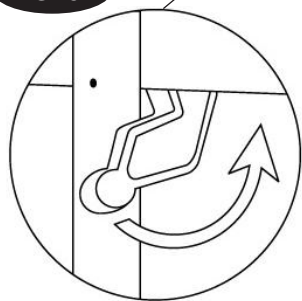

FIG. 8A



English

STEP 9:

- Place the Net Posts (#27) onto both sides of the same table half. See Fig. 9.
- Slide the Net (#28) over the post at one end of the table, stretch it to the opposite side, and slide it over the corresponding post. See Fig. 9 and 9A.

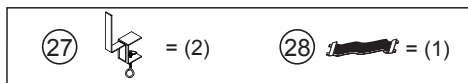

FIG. 9A

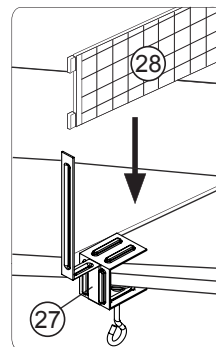
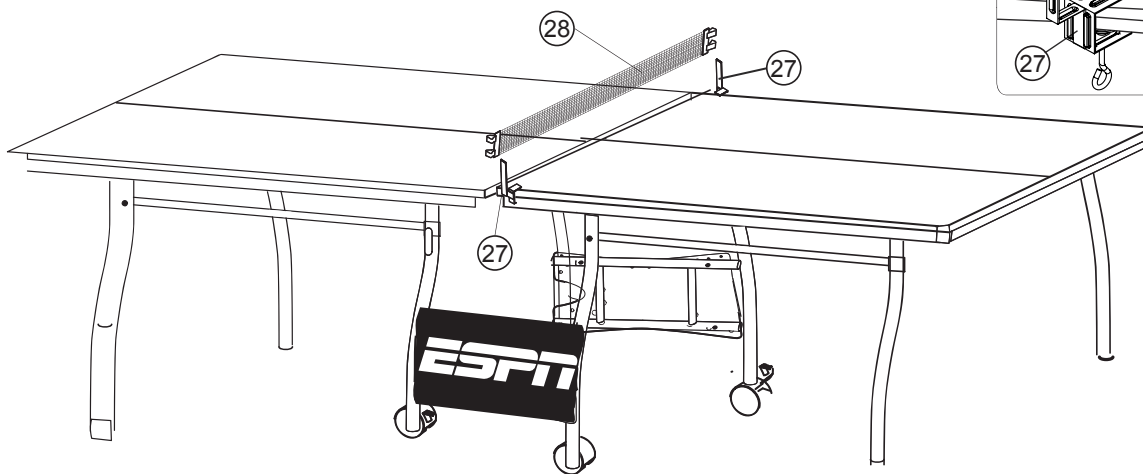

FIG. 9



English

STEP 10:

- Attach the Control Box (#25) to the underside of the table surface using four Screws (#47) as shown in figures 10 and 10A. **NOTE:** The Control Box must be attached to the same table half as the net.
- Place the two Electronic Scorers (#23 and #24) onto the Net Post (#27) as shown in Fig. 10. **NOTE:** Make sure to gently slide the front gap of the Electronic Scorers over the net.





23		= (1)
24		= (1)
25		= (1)
47		= (4)

FIG. 10A

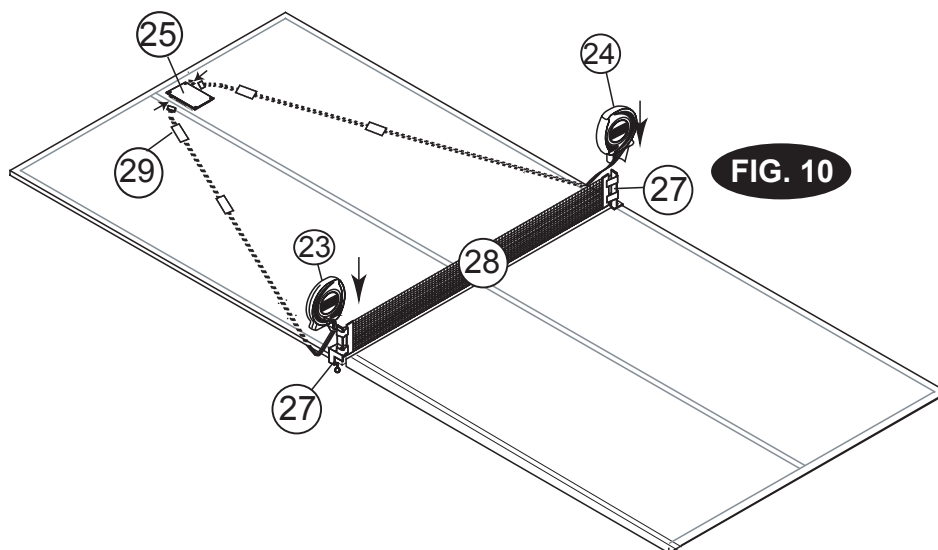
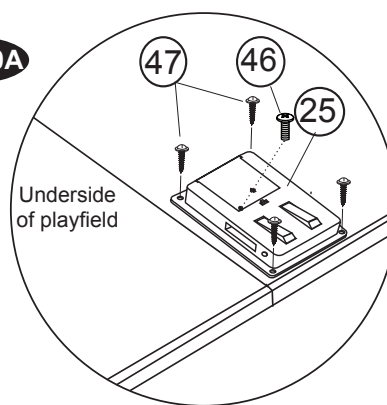

FIG. 10

English

STEP 11:

- From underneath the table, connect the wires coming off the Scorers into the Control Box (#25). See Fig. 11B.
- **NOTE:** There are "Home" and "Visitor" labels on the Control Box. Make sure the Electronic Scorer - Home is connected to "Home" and Electronic Scorer - Visitor is connected to "Visitor".
- Remove the battery cover and insert three AA Batteries (not included) in the order of the polarity as shown on the inside of the battery box.
- Peel the wax paper off the self-adhesive tape and attach it to the wires at the underside of the table. See figures 11 and 11C. Assembly of your table is completed. **YOU ARE NOW READY TO PLAY.**
- **NOTE:** Please clean the battery contacts of the device prior to battery installation. Make sure to remove batteries from the scorer when not used for an extended period of time. Remove used batteries promptly.
- **NOTE:** Do not mix old and new batteries. Do not mix alkaline, standard (carbon - zinc), or rechargeable (nickel cadmium) batteries.

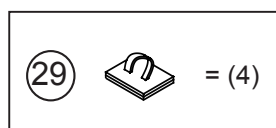

FIG. 11C

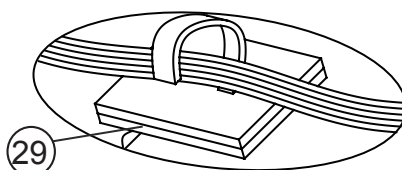

FIG. 11B

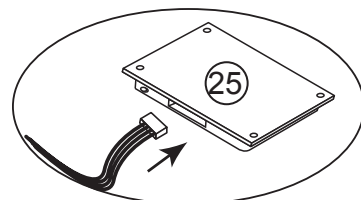
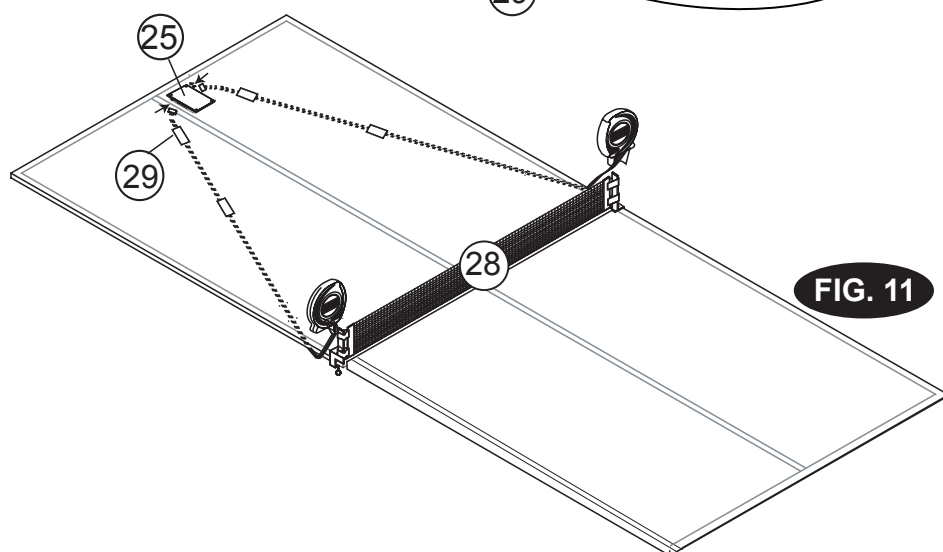

FIG. 11



English

STEP 12:

- **ATTENTION:** REMOVE NET BEFORE FOLDING TABLE FOR STORAGE POSITION. Failure to remove net prior to folding for storage may result in Gravity Lock malfunction.
- To Close the Table: Engage the Caster Locks. See Fig. 12.
- Raise one end of the table (no net) and close the legs until the Gravity Lock latches onto the table. See Fig. 12A.
- Close the Safety Strap Buckle (#22) and Safety Strap (#21) together. See Fig. 12C.
- To open the table, do the reverse of the above. See Fig. 12D.

FIG. 12

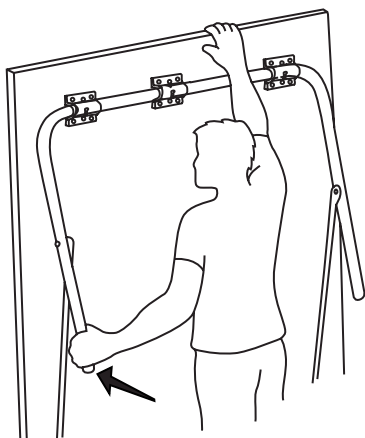

TO CLOSE

FIG. 12A

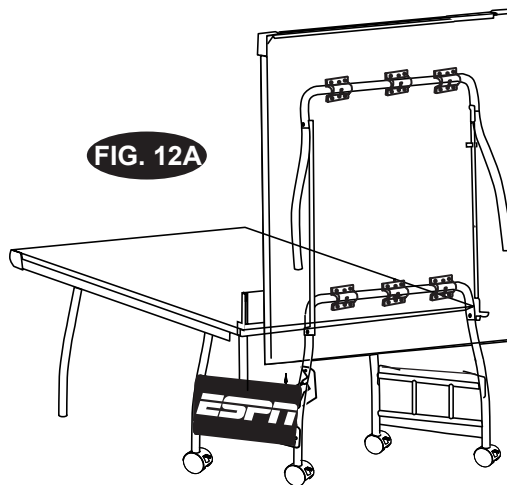

TO OPEN

FIG. 12B

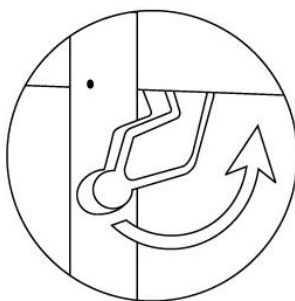

FIG. 12D

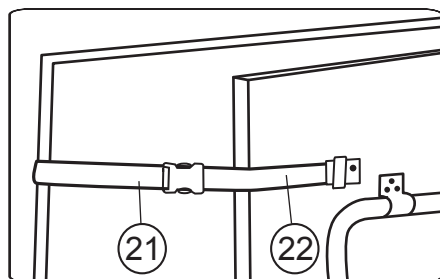

FIG. 12C



Frequently Asked Questions (FAQs):

1) **Q:** How can I tell which leg is left or right?

A: The left and right of a table are determined by the player's starting position. See illustration below.

- 1 = Left
- 2 = Right
- 3 = End

2) **Q:** Should there be a gap in the table halves?

A: Yes, you should have a 1/2-1" gap.

3) **Q:** What if the gap on my table too big?

A: If the gap is larger than one inch, the Welded Spreaders with Threads have been assembled upside down. Complete the following steps for each Welded Spreader.

- Make sure the table is open, in the play position, and make sure to support the table before attempting to fix the other side.
- Remove the assembled Plastic Leg Panel/Welded Spreader with Threads.
- Flip the Welded Spreader with Threads over, and reinstall both part.

Preguntas frecuentes (FAQs):

1) **P:** ¿Cómo puedo determinar cual carrile de mesa es el izquierdo o el derecho?

R: El izquierdo y el derecho de una mesa son determinados por la posición de partida del jugador. Ver la ilustración abajo.

- 1 = Izquierdo
- 2 = Derecho
- 3 = Extremo

2) **P:** ¿Debería haber un hueco entre las mitades de mesa?

R: Sí, usted debería tener un hueco de 1/2 pulg. a 1 pulg. (1,27 cm a 2,54 cm).

3) **P:** ¿Y si el hueco de mi mesa es demasiado grande?

R: Si el hueco es más grande que una pulgada, los apoyos de marco soldado con hilos han sido montadas al revés. Complete los pasos siguientes para cada apoyos de marco soldado con hilos.

- Asegúrese que la mesa está abierta, en la posición de juego, y asegúrese apoyar la mesa antes del intento de fijar el otro lado.
- Quite el apoyo de marco soldado con hilos/panel de pierna plástico montados.
- Haga girar el apoyo de marco soldado con hilos, e instale de nuevo ambas piezas.

Foire Aux Questions (la FAQ):

1) **Q:** Comment distingue-t-on le côté gauche et le côté droit de la table?

R: C'est la position du joueur au début qui détermine le côté gauche et le côté droit de la table (voir illustration ci-dessous).

- 1 = gauche
- 2 = droit
- 3 = extrémité

2) **Q:** Devrait-il y avoir une vide entre les moitiés de table ?

R: Oui, vous devriez avoir une vide de 1/2 po à 1 po (1,27 cm à 2,54 cm).

3) **Q:** Et si la vide de ma table trop large?

R: Si la vide est plus large qu'un pouce, les cadres soudés avec supports ont été montés à l'envers. Faites les étapes suivantes pour chaque cadre soudé avec supports.

- Assurez-vous que la table est ouverte, dans la position à jouer et assurez-vous de soutenir la table avant la tentative de fixer l'autre côté.

- Enlèvez l'assemblée d'entretoise de pattes plastique/cadre soudé avec supports.

- Renversez le cadre soudé avec supports et fixez de nouveau les deux pièces.

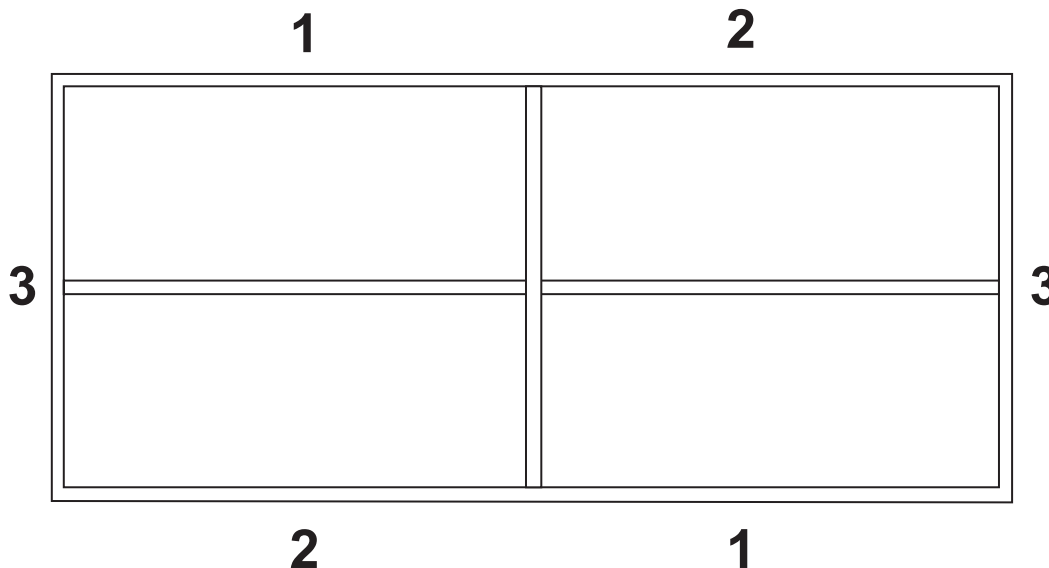

SCORER OPERATION:

- **NOTE:** This automatic serve count electronic scorer is tournament approved for scoring up to 11 points only. New rules for the United States Table Tennis Association (USTTA), and International Table Tennis Federation (ITTF) specify 11 point games. Remove the battery cover and insert three AA Batteries (not included) in the order of the polarity as shown on the inside of the battery box. (If the game will not be used for a long period of time, we recommend that the batteries be removed.)
- Turn on the scorer by turning the ON/OFF switch to the ON position. Scorer will proceed with its self-evaluation and “11” will be shown on both screens with all Server lights blinking.
- There are two modes of serving:
 - 1) Two serves per side.
 - 2) Five serves per side.
- You may choose to play a game up to 11, 15, or 21 points. Press the “11/15/21 Points” button to select and “11” or “15” or “21” which will show on both screens.
Press the “SERVE” button to select the desired server mode. Five Server Lights will blink to serve five times and two Server Lights will blink to serve two times. If there is no mode selected, the scorer will default to five serves per side.
- Press “HOME+” or “VISITOR+” to select the Player who will serve the ball first. When “HOME+” is selected, the “HOME” Server LED Light will turn on and the “VISITOR” Server LED Light will turn off. Both scores will now be “00”.
- To record points press the “HOME+” button when the “HOME” Player scores or “VISITOR+” when the “VISITOR” Player scores.
- Press the “HOME -” button and “VISITOR -” button to reverse the scorer for each player.
- After one team finishes serving, the Server Lights will change to the opposite Player’s Server Lights.
- To win:
 - 1) 11 Point-Game - the first Player to reach 11 points wins.
 - 2) 15 Point-Game - the first Player to reach 15 points wins.
 - 3) 21 Point-Game - the first Player to reach 21 points wins.

In the case of a tie, both players have 10 (or 14 or 20) points in an 11 (or 15 or 21)-point game. You must continue to play until one player and wins by a 2 points. The serve will follow the serving mode chosen at the beginning of the game.
- The winner’s light will flash for 30 seconds to signal they have won the game. Now press the “HOME+” or “VISITOR+” button to select which Player will begin to serve the ball next game. If you do not select a player, the computer will automatically turn back reset to the

English

beginning status, and you will need to select the server mode again.

- **NOTE:** The scoreboard will shut off automatically after 15 minutes if not in use. However, we suggest turning the power off when the game will not be used for an extended period of time.

TABLE TENNIS RULES:

DEFINITIONS:

- A “rally” is the period during which the ball is in play.
- A ball is “In Play” once the ball is intentionally projected in service.
- A “let” is a rally, the result of which is not scored.
- A “point” is a rally, the result of which is scored.
- A “racket hand” is the hand which holds the racket.
- To “strike” is to touch the ball with the racket while carried in the racket hand, or with the racket hand below the wrist.
- To “volley” is to strike the ball in play without it having first touched the playing surface on the player’s side of the net since last being struck by the opponent.
- The “server” is the player required to strike the ball first in a rally.
- “Around the net” means under or around the projection of the net and its supports outside the table, but not between the end of the net and post.
- The part of the playing surface nearest the server and to his right of the center line is called the “server’s right hand court” and to his left the “server’s left hand court.” The part of the playing surface on the other side of the net from the server and to his left of the center line is called the “receiver’s right hand court.”
- A player “obstructs” the ball if he, or anything he wears or carries, touches it in play when it is above or traveling towards the playing surface, not having touched his court since last being struck by his opponent.

THE ORDER OF PLAY:

In singles: The server first makes a good service and then the receiver makes a good return. Thereafter, server and receiver alternately each make a good return.

In doubles: The server first makes a good service and the receiver returns the ball. Then the partner of the server makes a good return, followed by the partner of the receiver returning the ball. Thereafter, each player alternately in that sequence makes a good return.

A GOOD SERVICE:

Service begins with the ball resting on the palm of the free hand, which must be open and flat. The server then projects the ball upwards and strikes it before the ball touches anything. At the moment of impact of the racket on the ball, the ball must be behind the end line of the server’s court or any imaginary extension thereof and above the level of the playing surface. From the start of service until it is struck, the ball shall be above the level of the playing surface and behind the server’s end line, and it shall not be hidden from the receiver.

English

In singles: After striking it, the ball must first touch the server's own court and pass directly over the net or around the net assembly, then touching the receiver's court.

In doubles: The ball must first touch the server's right half-court or center line, pass over the net, and then touch the receiver's right half-court or center line. If, in attempting to serve, a player fails to strike the ball while it is in play, he loses a point.

A GOOD RETURN:

The ball, having been served or returned, shall be struck so that it passes over or around the net assembly and touches the opponent's court, either directly or after touching the net assembly.

BALL IS IN PLAY-UNTIL:

The ball is in play from the last moment at which it is stationary on the palm of the server's free hand before being projected in service until:

- A point is scored.
- It touches the same court twice consecutively.
- It has been volleyed.
- It touches a player, or anything he wears or carries, other than his racket or his racket hand below his wrist.
- It touches any object other than the net or its support (referred to above).
- It is struck by a player more than once consecutively.
- It is struck, in doubles, by a player out of sequence, except where there has been a genuine error in playing order.

A ball which strikes the top edge of the table is still in play. A ball that strikes the side of the table below the edge, is out of play, so the play and the point are counted against the last striker.

A LET:

The rally is a let:

- If the ball is served, and in passing over or around the net it touches the net or its supports, provided the service is otherwise good or the ball is obstructed by the receiver or his partner.
- If a service is delivered when the receiver or his partner is not ready, except that a player may not be considered unready if he or his partner attempts to strike the ball.
- If owing to an accident outside his control, a player fails to make a good service or a good return or otherwise violates a rule.
- If it is interrupted for correction of an error in playing order.

LOSS OF POINT:

Unless the rally is a let, a player loses a point:

- If he fails to make a good serve.
- If he fails to make a good return.
- If he volleys the ball.
- If he strikes the ball with the side of the racket blade which has an illegal surface.
- If he, or anything he wears or carries, moves the playing

English

surface while the ball is in play.

- If he, or anything he wears or carries, touches the ball in play before it has passed over the end line or side line not yet having touched the playing surface on his side of the net since being struck by his opponent.
- If his free hand touches the playing surface while the ball is in play.
- If he, or anything he wears or carries, touches the net or its supports while the ball is in play.
- If, in doubles, he strikes the ball out of proper sequence.

A GAME:

House Rules: A game is won by the player or pair first scoring 21 points unless both players or pairs have scored 20 points. In this case, the winner is the player or pair to first score 2 points more than the opposing player or pair.

International Rules: A game shall be won by the player or pair first scoring 11 points unless both players or pairs score 10 points, when the game shall be won by the first player or pair subsequently gaining a lead of 2 points.

A MATCH:

A match shall consist of the best of any three or five games.

THE CHOICE OF ENDS AND SERVICE:

The choice of ends and the right to serve or receive first in a match shall be decided by a toss. The winner of the toss may:

- Choose to serve or receive first, and then the loser has the choice of ends.
- Choose an end, and then the loser has the choice to serve or receive first.
- Require the loser to make first choice.

In doubles: The pair having the right to serve first in any game decides which partner will do so. In the first game of a match, the opposing pair then decides which partner will receive first. In subsequent games of a match, the serving pair chooses their first server and the first receiver then is established automatically to correspond to the first server.

THE CHANGE OF ENDS:

House Rules: The player or pair who started at one end in a game starts at the other end in the next game and so on, until the end of the match. In the last possible game of a match, the players or pairs shall change ends when the first player or pair reaches the score of 10.

International Rules: The player or pair starting at one end in a game shall start at the other end in the next game of the match and in the last possible game of a match the players or pairs shall change ends when the first one player or pair scores 5 points.

THE CHANGE OF SERVICE:

In singles: After five points, the receiver becomes the server and so on, until the end of the game or the score 20-20. From the score of 20-20, each player delivers only one service in turn until the end of the game.

In doubles:

- The first five services are delivered by the selected partner of the pair who has the right to serve and are received by the appropriate partner of the opposing pair.
- The second five services are delivered by the receiver of the first five services and are received by the partner of the first server.
- The third five services are delivered by the partner of the first server and are received by the partner of the first receiver.
- The fourth five services are delivered by the partner of the first receiver and are received by the first server.
- The fifth five services are delivered and received as the first five, and so on until the end of the game, or the score 20-20.
- From the score 20-20 the sequence of serving and receiving are the same, but each player delivers only one service in turn until the end of the game.

The player or pair who served first in a game receives first in the next game and so on, until the end of the match. In the last possible game of a doubles match, the receiving pair changes the order of receiving when either pair first reaches the score of 10. In each game of a doubles match, the initial order of receiving is opposite to that in the immediately preceding game.

SERVING OR RECEIVING OUT OF ORDER:

- If, by mistake, the players neglect to change ends when required, play is interrupted as soon as the error is discovered and the players change ends. If a game has been completed since the error, the error is ignored.
- If, by mistake, a player serves or receives out of turn, play is interrupted and continues with that player serving or receiving who, according to the sequence established at the beginning of the match, should be server or receiver respectively at the score that has been reached.

