



PALI spa
 via del Collio 67
 33048 San Giovanni al Natisone
 Udine Italy
 Tel. +39 0432 756074
 info@pali.it
 www.pali.it

cot / berceau / lettino / cuna
TUCSON

CONFORMS TO THE SAFETY REGULATIONS
 CONFORME AUX EXIGENCES DE SECURITE
 CONFORME ALLE NORME DI SICUREZZA
 CONFORME A LAS NORMAS DE SEGURIDAD









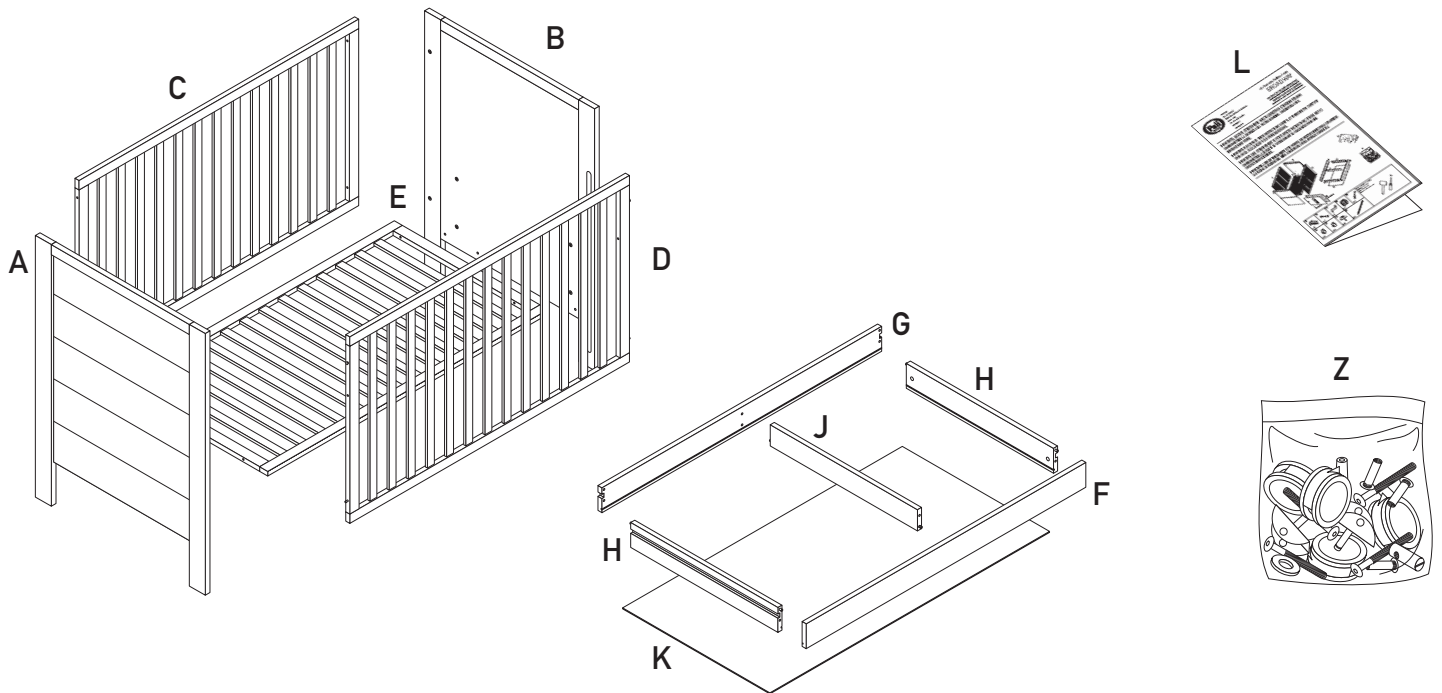

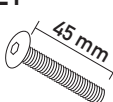
IMPORTANTE: LEGGERE ATTENTAMENTE QUESTO LIBRETTO DI ISTRUZIONI PER NON COMPROMETTERE LA SICUREZZA DEL VOSTRO BAMBINO. CONSERVARLO PER INFORMAZIONI FUTURE.

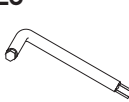
IMPORTANT: PLEASE READ THESE INSTRUCTIONS CAREFULLY TO ENSURE THE SAFETY OF YOUR CHILD. PLEASE KEEP FOR FUTURE REFERENCE.

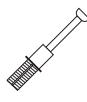
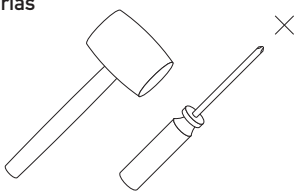
IMPORTANT: LIRE ATTENTIVEMENT CE PETIT LIVRET D'INSTRUCTIONS AFIN DE NE PAS COMPROMETTRE LA SÉCURITÉ DE VOTRE ENFANT. LE CONSERVER POUR UNE CONSULTATION ULTÉRIEURE.

IMPORTANTE: LEER DETENIDAMENTE ESTE MANUAL DE INSTRUCCIONES PARA GARANTIZAR LA MÁXIMA SEGURIDAD DEL NIÑO. CONSERVARLO PARA FUTURAS CONSULTAS.



Z1  x 8	Z2  x 2	Z3  x 1	Z4  x 6	Z5  x 6	Tools needed for assembly Outillage nécessaire Attrezzi necessari Herramientas necesarias 
Z6  x 2	Z7  x 2	Z8  x 4	Z9  x 4	Z10  x 2	

UK Since the lowest position of the base is the safest, use it as soon as the baby is at an age when he can sit up. It is dangerous to: - leave something in the cot that could represent a foot-hold or constitute a suffocation or strangulation hazard for the child; - put the cot near a heat source (gas or electrical appliances), which could constitute a fire hazard. The mattress selected must be such that the inner height (that is the distance between the surface of the mattress and the top of the bed) is at least 500 mm in the lowest position of the base and at least 200 mm in the highest position. We recommend using a mattress that is 118x58 cm and 10 cm thick max. The assembly devices must always be properly tightened. Regularly check to make sure that the screws are properly tightened; if not, tighten them to avoid snagging or hooking (clothing, chain, etc.) as this could constitute a strangulation hazard.

IMPORTANT: In order to properly assemble the cot, carry out the operations in the order specified. Failure to assemble the crib in the manner recommended could make the crib hazardous.

Never use the cot if even a single part is damaged, worn or missing. Use only manufacturer-approved spare parts. Do not place more than one mattress in the cot.

F La position la plus basse du sommier étant la plus sûre, utiliser cette position dès que le bébé est en âge de s'asseoir. Il est dangereux: de laisser quelque chose dans le lit qui pourrait fournir une prise pour le pied de l'enfant ou présenter un danger d'étouffement ou d'étranglement, de placer le lit auprès d'une source de chaleur (appareils à gaz ou électriques) ce qui pourrait déclencher un risque d'incendie. Le matelas choisi doit être tel que la hauteur intérieure (c'est à dire la distance de la surface du matelas jusqu'à la partie supérieure du lit) soit d'au moins 500 mm dans la position la plus basse du sommier et d'au moins 200 mm dans la position la plus haute. Il est recommandé d'utiliser un matelas de dimensions 118x58 cm, épaisseur 10 cm maxi. Les dispositifs d'assemblage doivent toujours être convenablement serrés. Vérifier régulièrement le vissage des vis, et revisser si nécessaire afin d'éviter tous risques d'accrochage (vêtements, chaînette, etc...) ce qui pourrait présenter un risque d'étranglement.

IMPORTANT: Pour obtenir un montage correct, veuillez effectuer les opérations dans l'ordre indiqué. Un montage différent de celui préconisé peut rendre le lit dangereux.

Ne pas utiliser le lit s'il a des parties endommagées, usées ou manquantes, et n'utiliser que des pièces de rechange approuvées par le fabricant. Ne jamais utiliser plus d'un matelas dans le lit. Pour prévenir tout risque de chute, quand l'enfant devient capable de grimper hors du lit, ne plus utiliser ce dernier.

I La posizione bassa della rete è la più sicura; utilizzare tale posizione appena il bambino comincia a stare seduto. È pericoloso: - lasciare qualcosa nella culla che possa imprigionare i piedi o creare rischi di soffocamento o strangolamento per il bambino; - avvicinare il lettino a fonti di calore (apparecchi a gas o elettrici), che possano creare rischi d'incendio. Il materasso scelto deve essere tale da avere almeno una distanza di 500 mm tra la superficie del materasso e i lati superiori delle sponde con la rete in posizione bassa e 200 mm con la rete in posizione alta. Raccomandiamo di utilizzare un materasso di dimensioni 118x58 cm, spessore 10 cm max. Le varie parti del lettino devono sempre essere serrate saldamente. Controllare periodicamente che le viti siano ben avvitate; in caso contrario, serrarle completamente per evitare che qualcosa (catenine, indumenti ecc.) vi si possano agganciare causando rischi di strangolamento.

IMPORTANTE: Per il corretto montaggio, seguire le operazioni nell'ordine indicato. Un montaggio errato potrebbe rendere il lettino pericoloso.

Non utilizzare il lettino se una parte fosse danneggiata, usurata o mancante e utilizzare solamente parti di ricambio approvate dal costruttore. Non utilizzare più di un materasso nel letto. Per prevenire il rischio di cadute, quando il bambino è in grado di arrampicarsi al di fuori del lettino, tale lettino non va più utilizzato.

E La posición baja del somier es la más segura; utilizar dicha posición en cuanto el niño empiece a estar sentado. Es peligroso: - dejar algo en la cuna que pueda atrapar los pies o generar riesgos de ahogo o estrangulamiento para el bebé; - acercar la cuna a fuentes de calor (aparatos a gas o eléctricos), que puedan generar riesgos de incendio. El colchón seleccionado, deberá tener como mínimo una distancia de 500 mm. entre la superficie del colchón y los lados superiores de las barandillas, con el somier en posición baja, y 200 mm. con el somier en posición alta. Recomendamos utilice un colchón de tamaño 118x58 cm., espesor 10 cm. máx. Las diferentes partes de la cuna, deberán estar siempre bien apretadas. Controle periódicamente que los tornillos estén bien atornillados; de lo contrario, apretarlos totalmente para evitar que algo (cadenas, prendas, etc.) se enganche causando riesgos de estrangulamiento.

IMPORTANTE: Para el correcto montaje, llevar a cabo las operaciones en el orden indicado. La cuna mal montada podría ser peligrosa.

No utilizar la cuna si falta alguna parte o está dañada y utilizar sólo piezas de recambio aprobadas por el fabricante. No utilizar más de un colchón en la cuna. Para prevenir el riesgo de caídas, cuando el niño sea capaz de salirse de la cuna trepando, no seguir utilizándola.

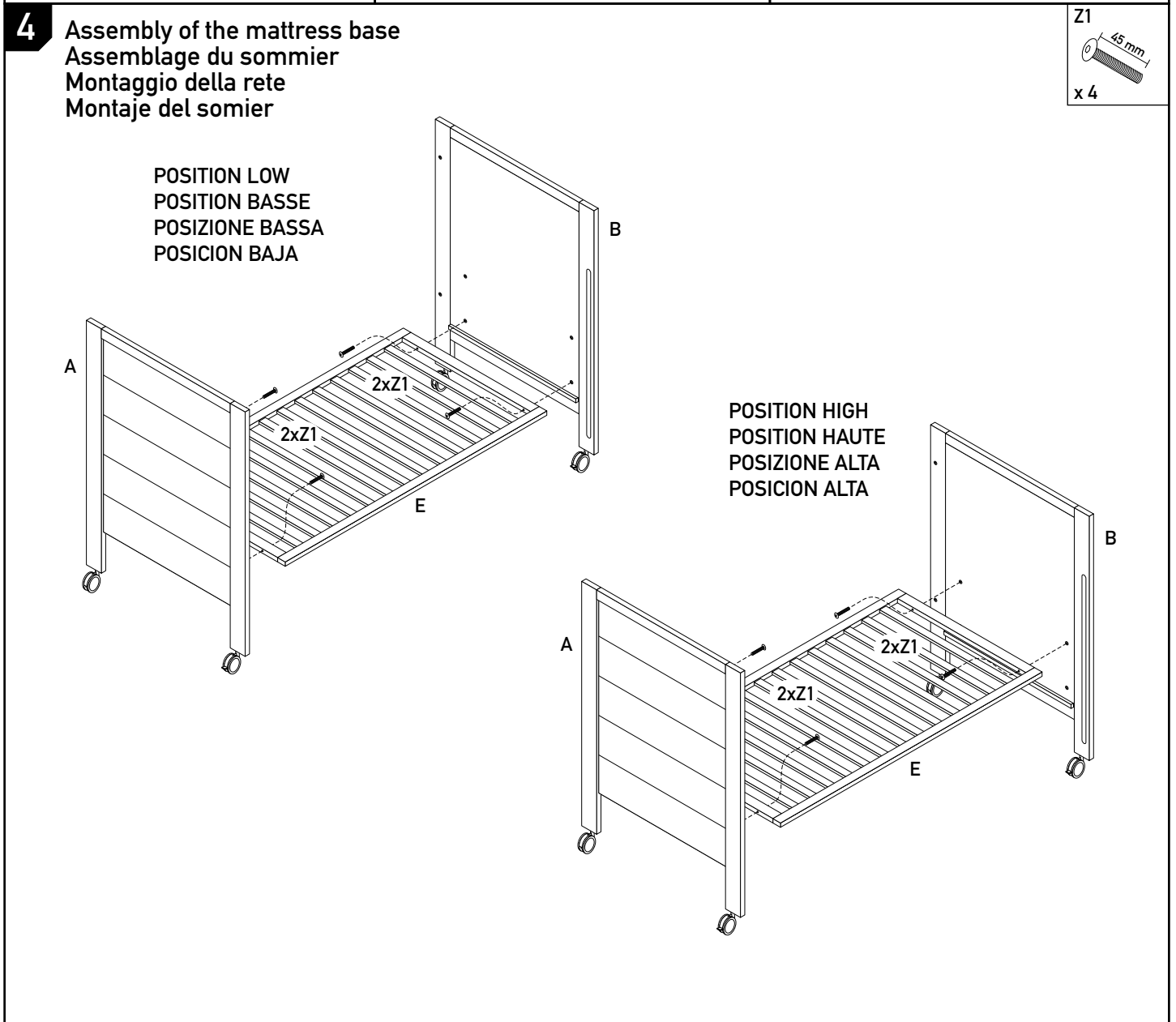
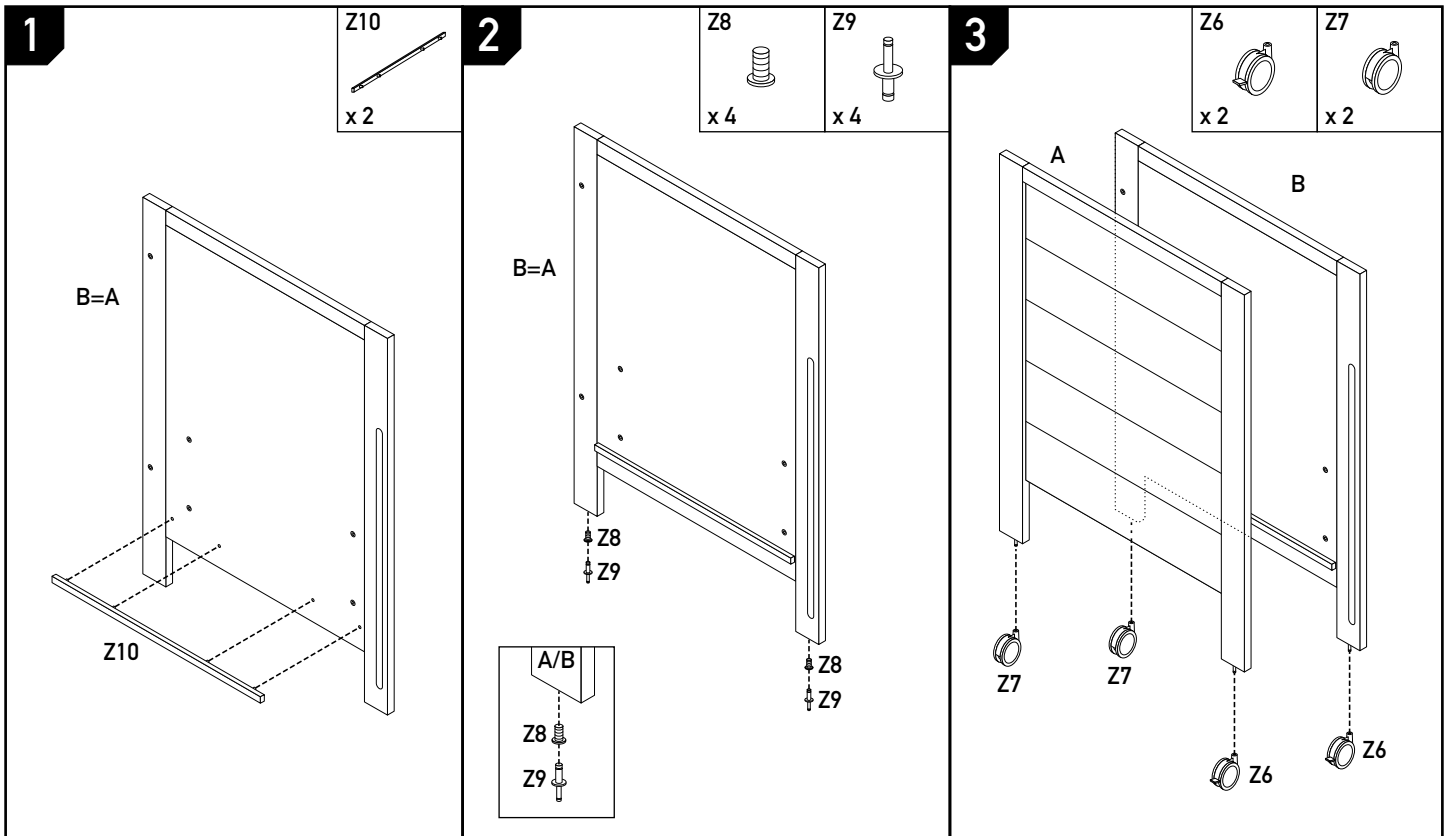

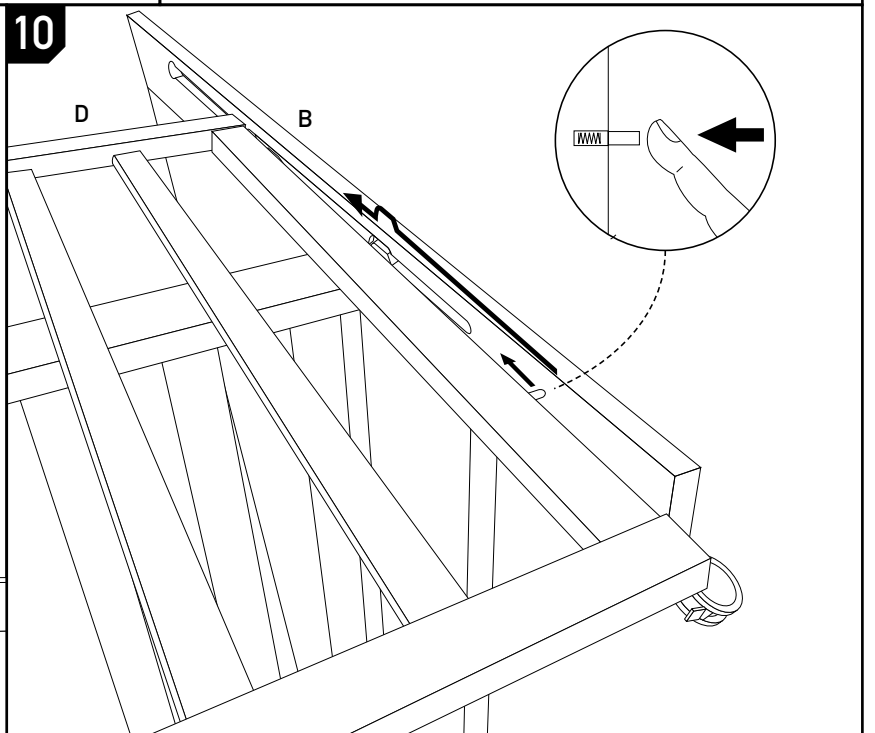
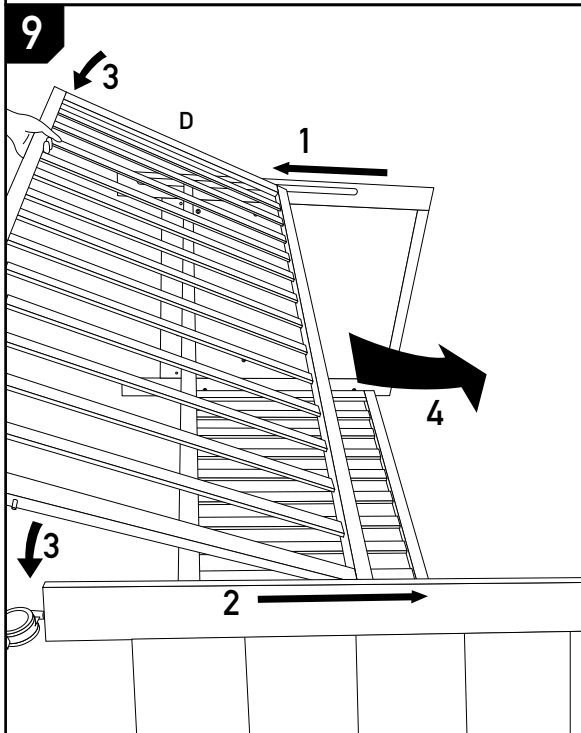
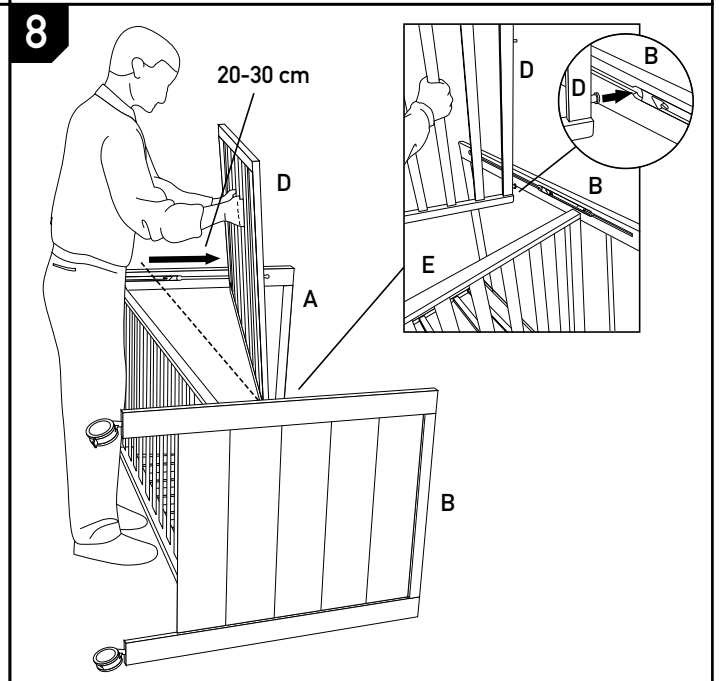
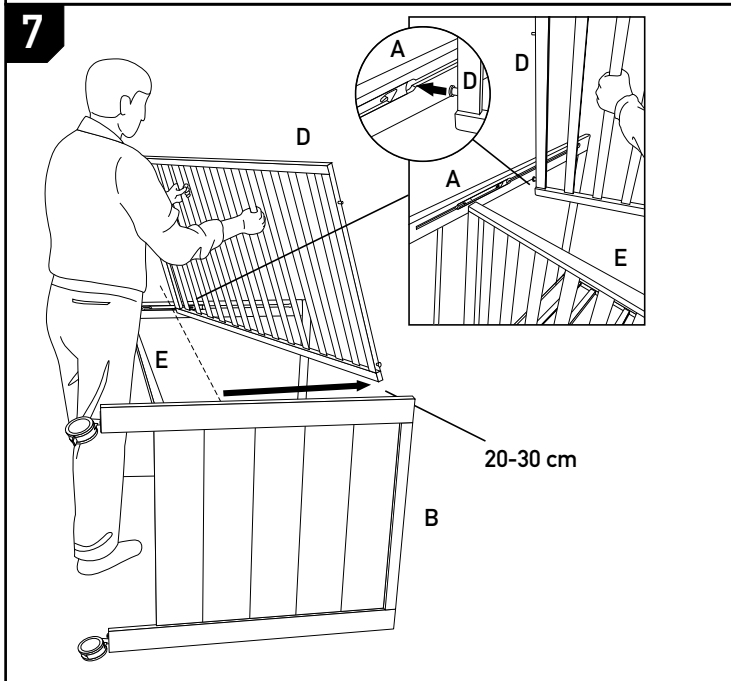
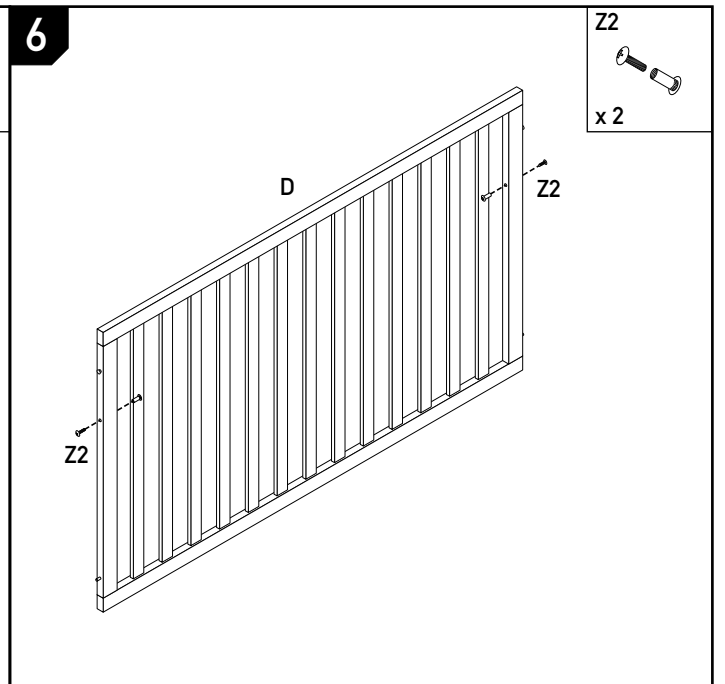
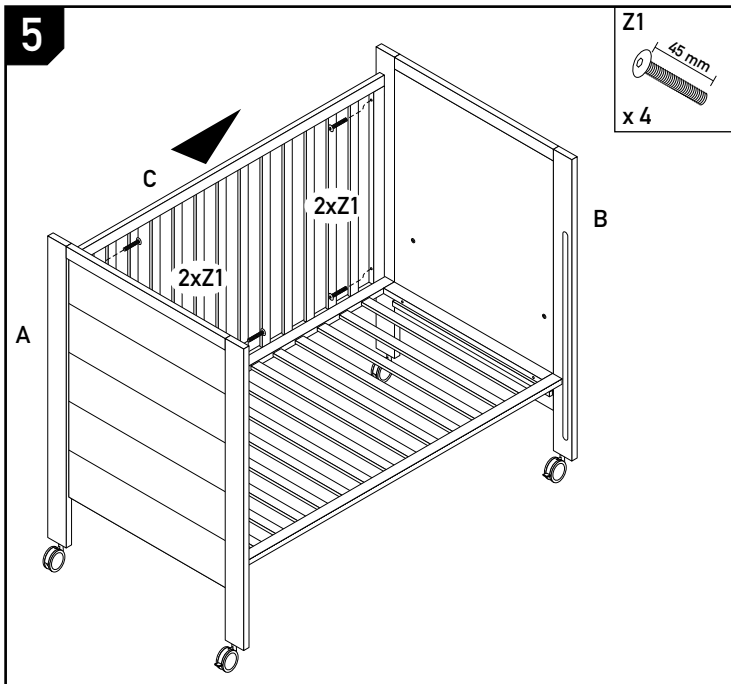

11

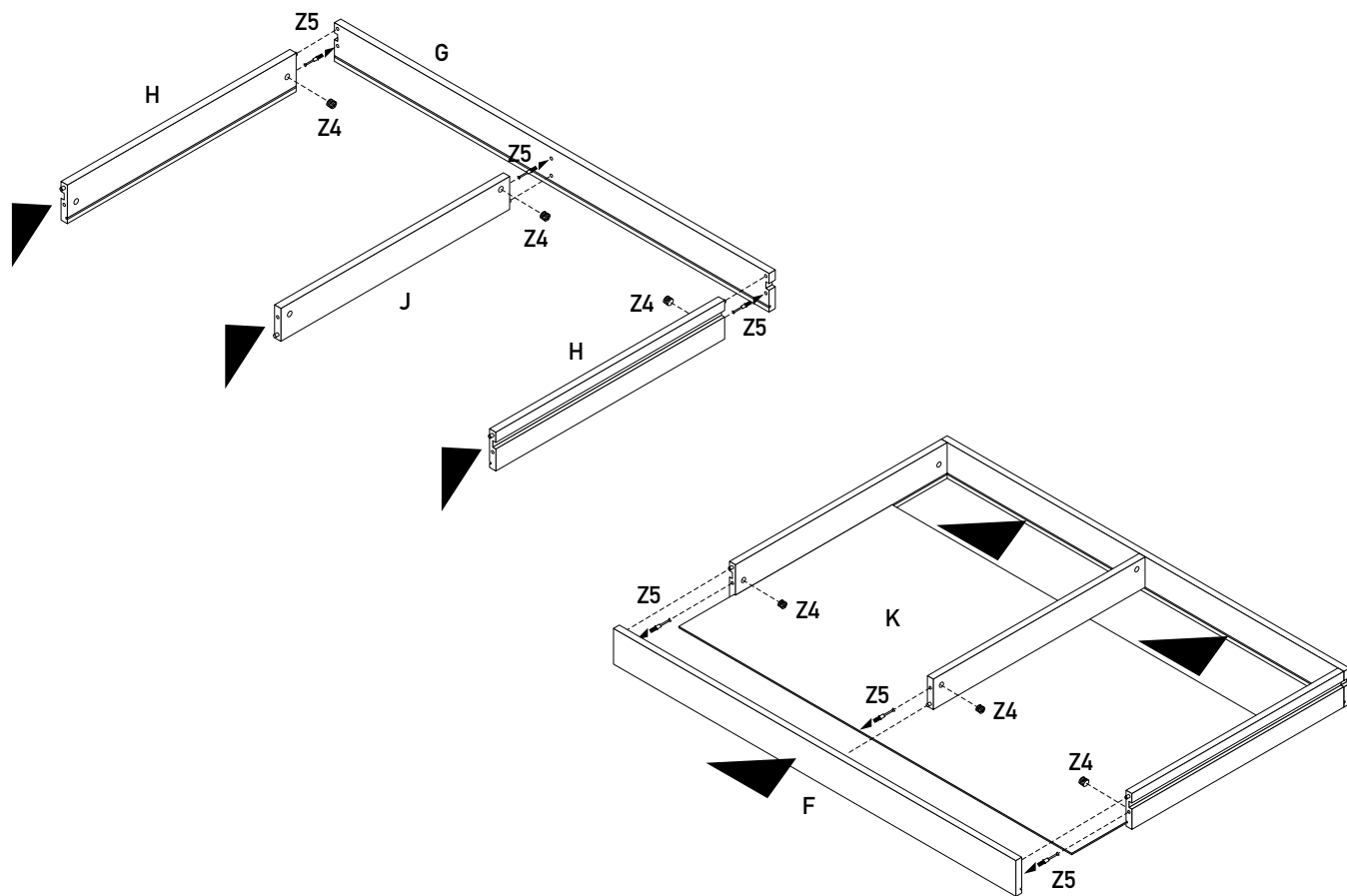
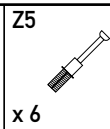
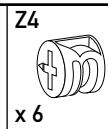
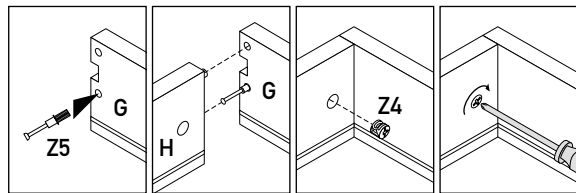

12

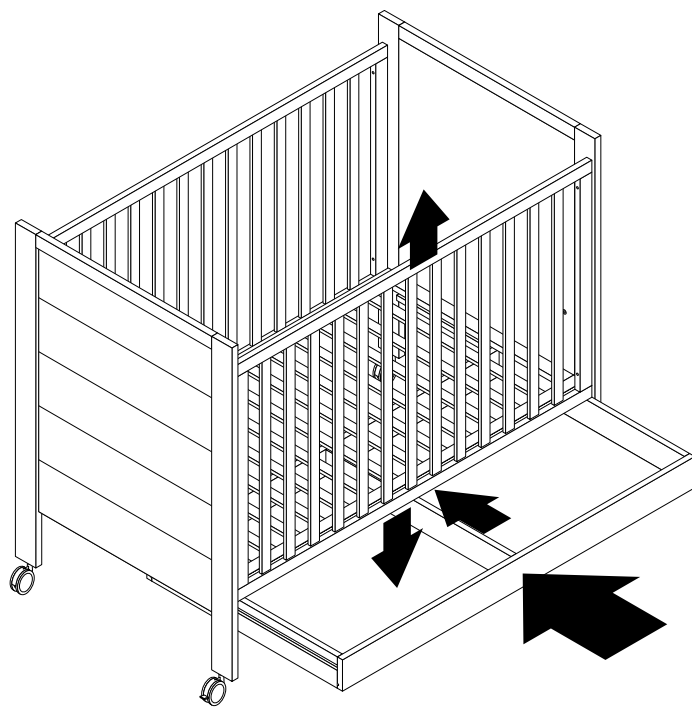

PARTS REPERE COMPONENTI ELEMENTOS	Q.TY Q.TE Q.TÀ C.DAD	DESCRIPTION PART DESIGNATION PIECE DESCRIZIONE ELEMENTO DESCRIPCIÓN ELEMENTO	COMPOSITION DESIGNATION MATIERE DESCRIZIONE MATERIALE COMPOSICIÓN
A	1	FOOTBOARD PIED PEDIERA PIE	BEECH+MDF COATED WITH POLYURETHANE VARNISH HETRE+MDF VERNIS POLYURETHANE FAGGIO+MDF VERNICIATO VERNICIATO CON VERNICE POLIURETANICA HAYA+MDF BARNIZADA CON PINTURA POLIURETÁNICA
B	1	HEADBOARD TETE TESTIERA CABECERA	BEECH+MDF COATED WITH POLYURETHANE VARNISH HETRE+MDF VERNIS POLYURETHANE FAGGIO+MDF VERNICIATO VERNICIATO CON VERNICE POLIURETANICA HAYA+MDF BARNIZADA CON PINTURA POLIURETÁNICA
C	1	STATIONARY SIDE COTE FIXE SPONDINA FISSA BARANDILLA FIJA	BEECH COATED WITH POLYURETHANE VARNISH HETRE MASSIV VERNIS POLYURETHANE FAGGIO VERNICIATO VERNICIATO CON VERNICE POLIURETANICA HAYA BARNIZADA CON PINTURA POLIURETÁNICA
D	1	DROPSIDE COTE MOBILE SPONDINA SCORREVOLE BARANDILLA MÓVIL	BEECH COATED WITH POLYURETHANE VARNISH HETRE MASSIV VERNIS POLYURETHANE FAGGIO VERNICIATO VERNICIATO CON VERNICE POLIURETANICA HAYA BARNIZADA CON PINTURA POLIURETÁNICA
E	1	MATTRESS BASE SOMMIER RETE SOMIER	BEECH HETRE MASSIV FAGGIO HAYA
F	1	DRAWER FRONT PANNEAU AVANT DE TIROIR FRONTALE CASSETTO FRENTE DEL CAJÓN	MELAMMINIC PARTICLEBOARD PANNEAU DE PARTICULES MELAMINE PANNELLO TRUCIOLARE MELAMMINICO TABLERO AGLOMERADO MELAMINICO
G	1	DRAWER BACK PANNEAU ARRIERE DE TIROIR PANNELLO POSTERIORE CASSETTO POSTERIOR DEL CAJÓN	MELAMMINIC PARTICLEBOARD PANNEAU DE PARTICULES MELAMINE PANNELLO TRUCIOLARE MELAMMINICO TABLERO AGLOMERADO MELAMINICO
H	2	DRAWER SIDE LATERAUX DU TIROIR FIANCO CASSETTO LADO DEL CAJÓN	MELAMMINIC PARTICLEBOARD PANNEAU DE PARTICULES MELAMINE PANNELLO TRUCIOLARE MELAMMINICO TABLERO AGLOMERADO MELAMINICO
J	1	DRAWER CENTER PARTITION SEPARATEUR DE TIROIR DIVISORIO CENTRALE CASSETTO PANEL CENTRAL DEL CAJÓN	MELAMMINIC PARTICLEBOARD PANNEAU DE PARTICULES MELAMINE PANNELLO TRUCIOLARE MELAMMINICO TABLERO AGLOMERADO MELAMINICO
K	1	DRAWER BOTTOM FOND DU TIROIR FONDO CASSETTO FONDO DEL CAJÓN	MDF MDF MDF MDF
L	1	ASSEMBLY INSTRUCTIONS NOTICE DE MONTAGE ISTRUZIONI DI MONTAGGIO INSTRUCCIONES DE MONTAJE	
Z	1	HARDWARE SET QUINCAILLERIE SACCHETTO FERRAMENTA BOLSAS DE HERRAJES	

HARDWARE SET
QUINCAILLERIE
SACCHETTO FERRAMENTA
BOLSAS DE HERRAJES

PARTS REPERE COMPONENTI ELEMENTOS	Q.TY Q.TE Q.TÀ C.DAD	DESCRIPTION PART DESIGNATION PIECE DESCRIZIONE ELEMENTO DESCRIPCIÓN ELEMENTO	PARTS REPERE COMPONENTI ELEMENTOS	Q.TY Q.TE Q.TÀ C.DAD	DESCRIPTION PART DESIGNATION PIECE DESCRIZIONE ELEMENTO DESCRIPCIÓN ELEMENTO
Z1	8	ALLENHEAD BOLT 45 mm VIS 45 mm VITE 45 mm TORNILLO 45 mm	Z6	2	CASTER WITH BRAKE ROULETTE AVEC FREINAGE RUOTA CON FRENO RUEDA FRENADA
Z2	2	COVER BOLTS CACHE TROUS COPPIA VITI COPRIFORO PAR DE TORNILLOS	Z7	2	CASTER ROULETTE RUOTA RUEDA
Z3	1	ALLEN KEY CLE DE MONTAGE CHIAVETTA ESAGONALE LLAVE HEXAGONAL	Z8	4	PLASTIC INSERT SUPPORT AXE ROULETTE BOCCOLA IN PLASTICA CASQUILLO DE INSERCIÓN PLASTICO
Z4	6	ECCENTRIC EXCENTRIQUE ECCENTRICO EXCÉNTRICA	Z9	4	METAL PIN TOURILLON DE METAL PERNO METALLICO PERNO METALICO
Z5	6	TIRANTE STAY BOLT TIRANT TIE	Z10	2	DRAWER PLASTIC GLIDE GLISSIERE PLASTIQUE POUR TIROIR GUIDE CASSETTO IN PLASTICA GUÍAS DE PLÁSTICO DEL CAJÓN