

Hotpoint Service and Spares

FOR SERVICE: If you have a problem with your appliance ring your local Service Office.
 FOR SPARES and ACCESSORIES: To purchase spares and accessories send your Accessories Order Form to your Spares Centre. If the accessory or spare part you want is not on the form, contact your Spares Centre for prices and availability.
 Please address all correspondence to Hotpoint Spares Centre or Hotpoint Service Office as applicable.

Service Offices and Spares Centres are open between 8.00am-5.00pm Monday to Friday, except on Public Holidays. 8.30am-12.30pm on Saturdays.

- Service Office and Spares Centre
- Service Office only

- EAST**
- **ESSEX:** Industrial Buildings, Beehive Lane, Chelmsford, CM2 9TE
Post Codes RM & IG Tel: (0245) 492433
Reminder of Essex Tel: (0245) 263931
 - **LUTON:** 5 Crawley Road, LU1 1HK, Tel: (0822) 452211
Celia Road, PE2 9JB, Tel: (0733) 64741
Spares Administration Dept. Tel: (0733) 556520
 - **PETERBOROUGH:**
 - **LONDON**
 - **WESHLEY:** 68 East Lane, HA9 7PQ, Tel: 081-904 4399
S. Harb and Middlesex Tel: 081-908 4722
Post Codes N, NW, E, EC Tel: 081-908 4722
Post Codes W, WC, SE, SW Tel: 081-908 2311
Tel: 081-904 0201
 - **MIDLANDS**
 - **BIRMINGHAM:** Westgate, Aldridge, W Midlands, WS9 8UX
Post Codes B Tel: (0922) 743374
All other Post Codes Tel: (0922) 743376
Tel: (0922) 743377
 - **NOTTINGHAM:** Ashling Street, NG2 3JB, For Spares Tel: (0692) 860387
Tel: (0692) 862437/864322 For Spares Tel: (0692) 860387
 - **STOKE:** West Ave, Nelson Estate, Talke, ST7 1TN, Tel: (0782) 774511
 - **NORTH EAST**
 - **HULL:** Custom House Building, Whitefriargate, HU1 2EU
Tel: (0482) 224777
8 Bede House, Tower Road, Gower Est. District 11, NE37 2SH
Tel: 091-417 3500/419 3535
Sandbeck Lane, LS22 4TW
Tel: (0957) 581261/581444 For Spares Tel: (0957) 581221
 - **WASHINGTON:**
 - **WETHERBY:** For Service
 - **NORTH WEST**
 - **KENDAL:** Murnford House, 20 Highgate, LA9 4SX, Tel: (0539) 724483
44/46 Station Road, Heaton Mersey, Stockport, SK4 3OT.
Manchester North Tel: 061-432 0513
Manchester South Tel: 061-442 8677
Tel: 061-432 0255
 - **MANCHESTER:** 7 Bridge Way, Messegate, Tel: 051-525 2342/524 2339
24/25 Cannon Street, Fri 3AM, Tel: (01772) 824311
 - **NEFTERTON:** For Spares
 - **PRESTON:**
 - **SCOTLAND**
 - **ABERDEEN:** Holbeck House, 66 Garden Place, AB1 1UL, Tel: (0224) 642283
35 West Bowling Green Street, Leith, EH6 5NX, Tel: 031-554 1431
West Lodge Road, Blythwood Estate, PA4 9FN
Tel: 041-866 6241 For Spares Tel: 041-866 5611
 - **RENFREW:** For Service
 - **SOUTH**
 - **KENT:** Lakfield Trading Est, New Hythe Lane, Larkfield, ME20 6SW
CT DA, ME & TN Kent Post Codes Tel: (0822) 716571
CR, KT, RH, SM Surrey & BR Kent Post Codes (0822) 790707
GU Post Codes in Surrey Tel Southampton (0703) 603734
Tel: (0822) 716531
 - **SOUTHAMPTON:** Unit R, S Hampshire Ind Park, Salisbury Rd, Totton, SO4 3SA
Tel: (0703) 861981/867374 For Spares Tel: (0703) 867933
1 Kingswood North St, Hantsham BN27 1DU, Tel: (0323) 842733
69 Mulvey Plain, PL4 6JH, Tel: (0152) 262931
 - **WALES**
 - **NORTH:** Conwy Rd, Llandudno Junction, LL31 9RE, Tel: (0492) 582626
18 Western Ave, Bridgend Ind Estate, Bridgend, CF31 3SL
Post Codes CF, SA & SY23-25 Tel: (0656) 664121
Post Codes BS, GL, (incl 55), HR, SY15-18, LD1-8, NP, Tel: (0696) 665554
Tel: (0656) 786111
 - **SOUTH:** For Service
 - **For Spares**

In accordance with its policy of progressive product design, the Company reserves the right to alter specifications.

Hotpoint Ltd, Peterborough, PE2 9JB, England
01604172207

<p>IRELAND</p> <ul style="list-style-type: none"> ● NORTHERN: 226 Ormeau Road, Belfast, BT7 2FZ, Tel: (0232) 647111 ● ERE: 49 Airways Ind Estate, Dublin 17, Tel: Dublin 4268068 Tel: Dublin 4268366 <p>For Service For Spares</p>	<p>CHANNEL ISLANDS – Service provided by Agents. Normal Guarantees apply and all Service Schemes are available.</p> <p>JERSEY: 19 Dun Street, St. Helier, Jersey, Tel: (0534) 21625 Clos D'Ormes, Pontac, St Clements, Tel: (0534) 54808</p> <p>GUERNSEY & SARK: Valons Spies, Grande Rue, St Martins, Guernsey, Tel: (0481) 38422 Barras Lane, Vale, Tel: (0481) 51610 32 High Street, Tel: (0481) 822896</p> <p>ALDERNEY: or</p>	<p>ISLE OF MAN – Service provided by Agents. Normal Guarantees apply and all Service Schemes are available</p> <p>from 5 Durnagold St, Douglas, Tel: (0524) 673233 or Torndon Works, Cronkbourne Village, Douglas, Tel: (0524) 676066 or 17 Ridgeway Street, Douglas, Tel: (0524) 25811/25948</p>	<p>SHETLAND, ORKNEY & WESTERN ISLES – Service provided by Agents. Normal Guarantees apply but Service Schemes are NOT available</p> <p>SHETLAND: Fort Road, Lerwick, Tel: (0363) 2567</p> <p>ORKNEYS: Halstone Ind, Esdale, Kirkwall, Tel: (0566) 54657</p> <p>WESTERN ISLES: 27 Bayhead Street, Stromoway, Isle of Lewis, Tel: (0851) 3387</p> <p>OTHER ISLANDS, EXCEPT ARRAN, BUTE & SKYE – Local Hydro Electric Shops, which are covered by Hotpoint.</p>
---	--	--	---

USER HANDBOOK – MODEL 9529

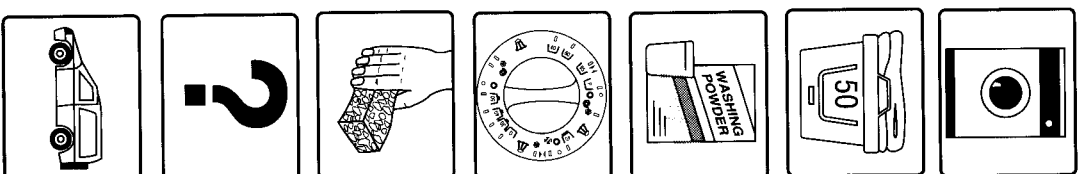

Contents	page
Before you operate your washing machine	2
Know your machine	3
How to do a wash	4
Sorting your laundry	6-7
Load your machine	8
Washing detergent	9
Fabric conditioner	10
Selecting your programme	10-11
Additional wash features	12
The machine at work	13
Caring for your machine	14
If you think you have a problem . . .	15-17
If it still won't work	18
Hotpoint Service Cover	19
Hotpoint Service Offices and Spares Centres	back page

Hotpoint®



Before you operate your Washing Machine

1. Make sure that your machine is correctly installed. Follow the Installation Instructions supplied with the machine. If the Installation Instructions are missing, please contact your nearest Hotpoint Spares Centre (see back page).

2. REMOVE THE TRANSIT BRACKET. YOU MUST NOT OPERATE THE MACHINE WITH THIS BRACKET IN PLACE.

Disconnect the machine from the electricity supply then follow the procedure as shown on the label on the back of the machine.

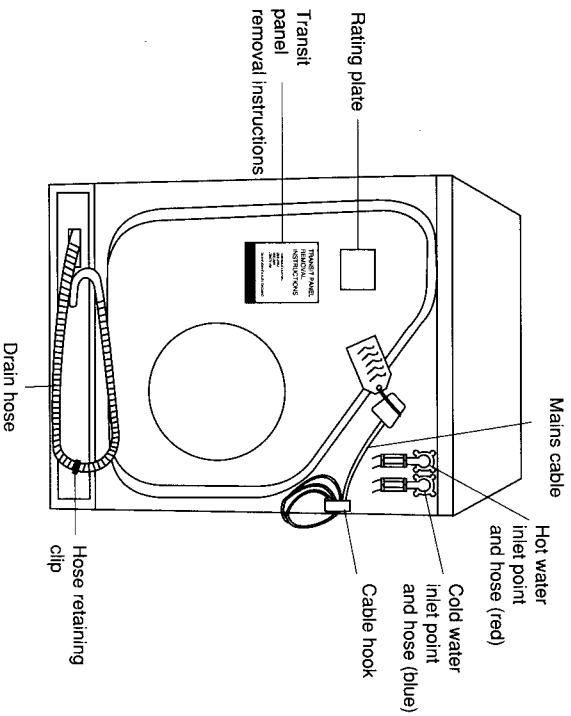

- After the transit bracket has been removed it is normal for the door seal to appear creased. This will not impair the function of the machine.
3. Read these Instructions **before** using your machine.

NOTE: Do not sit or stand on top of your washing machine; you could injure yourself or damage the machine by such abuse.

WARNING: IT IS POSSIBLE FOR CHILDREN AND ANIMALS TO CLIMB INTO WASHING MACHINES AND INJURE THEMSELVES

Hotpoint Service Cover

Satisfaction Guaranteed or Your Money Back

Hotpoint gives you a unique 'Satisfaction Guaranteed' promise – valid for ninety days after you have purchased your Hotpoint product. If there is a problem with your Hotpoint appliance just call your Hotpoint Service Office. If necessary we will arrange for an engineer to call. If the problem is not resolved by us under this Guarantee, Hotpoint will replace your appliance or, if you prefer, give you your money back. This Guarantee is additional and subject to the terms of Hotpoint's Five Year Parts Guarantee.

Hotpoint's Free Five Year Guarantee

From the moment your appliance is delivered, Hotpoint guarantees it for **FIVE YEARS**.

- In the Five Years all replacement parts are **FREE** provided they are fitted by our own Service Engineer. During the first year our Engineer's time and labour is also free.
- After the first year we will charge for our Engineer's time and labour. We do, however, operate a range of Service Plans (see opposite) which for an annual payment enables you to cover any repair costs which may be necessary.
- All of our service repairs are guaranteed for twelve months in respect of our labour and any parts fitted.
- The appliance must be used in the United Kingdom and must not be tampered with or taken apart by anyone other than our own Service Engineer.
- You may, however, buy parts which can be safely fitted without specialist knowledge or equipment. The correct fitting of such parts, provided they are genuine Hotpoint spares, will not affect your Guarantee. Parts are available from our main Hotpoint Spares Centres.
- Our Guarantee does not cover the cost of any repair which is needed because of power cuts, accidents or misuse. Nor does it cover the cost of any visit to advise you on the use of the appliance except for our Free Installation Check for Automatic Washing Machines and Dishwashers. Please read the instruction book thoroughly.
- If at any time during the Guarantee period we are unable to repair your appliance, we will refund any repair costs paid to us in the previous twelve months. We will also offer you a new appliance at a reduced charge instead of a repair.
- Our Guarantee is in addition to and does not affect your legal rights.
- Should you need independent advice on your consumer rights, help is available from your Consumer Advice Centre, Law Centre, Trading Standards Department and Citizens Advice Bureau.
- All Hotpoint servicing is done by our own Service Organisation located throughout the United Kingdom and Southern Ireland. It will be happy to deal with any problems.



Hotpoint's Installation Check

If you ask at your local Service Office (see back page), Hotpoint will send one of its trained Engineers to make sure that the appliance has been properly unpacked and correctly connected to existing water and electrical supplies. If you wish, the Engineer will be happy to explain how to use your new appliance.

Hotpoint's Service Care

Whether you have just one or a number of Hotpoint appliances in your kitchen, Hotpoint has a range of Service Schemes to give you complete peace of mind.

Service Cover

A single payment covers you for all repairs during the period of cover, which can be from 1 to 4 years. There is also an option of Service Cover with Maintenance at an additional cost. This includes an annual Electrical and Safety check and replacement of any parts as necessary. For 1 year contracts this takes place towards the end of the contract period.

Kitchen Cover

An annual payment covers you for all repairs for all your Hotpoint appliances which are less than 10 years old. It also covers the cost of loss of food up to £250 in our refrigeration and freezer products. There is also the option of Kitchen Cover with Maintenance at an additional cost. Any additional Hotpoint appliances purchased after you have joined Hotpoint Kitchen Cover will automatically be included during the annual period of cover without further charge.

Appliance Registration

To ensure that you have the opportunity to benefit from any of the above Service Schemes you should complete and return immediately the Appliance Registration Form supplied with your appliance. Full details and costs of our Service Schemes together with an application form will be sent to you at the end of the first year of the guarantee.

Annual Safety/Maintenance Checks

Hotpoint strongly recommends that all its appliances are regularly checked for electrical and mechanical safety whether or not they are covered by a Service Plan.

Proof of Purchase

For future reference please attach your purchase receipt to this booklet and keep it in a safe place.

Spares and Accessories

Spares and accessories can be ordered from your local Hotpoint Spares Centre (listed on the back page), using the order form enclosed.

NOTE: Our Engineer will use every effort to avoid damage to floor coverings and adjacent units when carrying out repair/service work but in locations where the Engineer advises you that it will be impossible to move the appliance without risk of damage, he will only proceed with your approval that no liability is accepted.



If it still won't work . . .

Know your Machine



Contact your local Service Office

If something is still wrong with your machine after you've been through the check-lists:

1. Switch off and unplug machine from the mains.
2. Turn off hot and cold taps.
3. Call your nearest Hotpoint Service Office or local importer (outside the UK). The telephone number is on the back page. Note down the number here for convenience.

Emergency door opening

If the machine is full of water with your clothes inside, you can open the door by following these instructions. You will need a bucket. First you have to empty some of the water, so that the safety latch will release the door.

1. Turn off the hot and cold taps, switch off the electricity and unplug the machine. Do not use machine again until the Service Engineer has called.
2. Pull out the machine so that you can get at the back of it.
3. Place the end of the Hose in a bucket to drain the water. Draw off about two bucketfuls.

WARNING: BE CAREFUL, THE WATER MAY BE VERY HOT.

4. When sufficient water has been removed you will be able to open the door.

If it still won't Work

6. If you have taken out a Hotpoint Service Cover Plan.

Please make sure you have all these details ready when you call.

5. The date of purchase. Enter the date here:

Retention of this Instruction Book

This Instruction Book must be kept handy for reference as it contains important details on the safe and proper use of the appliance.

If you sell or pass the appliance to someone else, or move house and leave it behind, make sure this Book is also provided so the new owner can become familiar with the appliance and safety warnings.

If the Book is lost or damaged a copy may be obtained from Hotpoint Ltd, Celita Road, Peterborough, PE2 9UB.

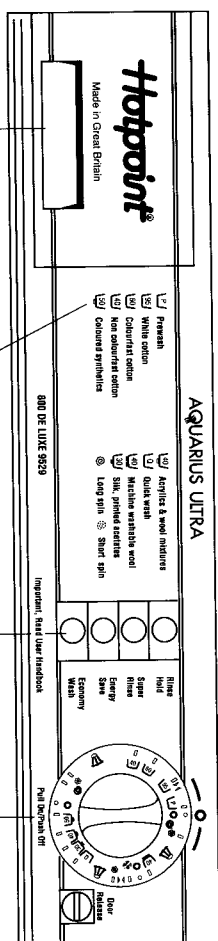

How to Open the Door

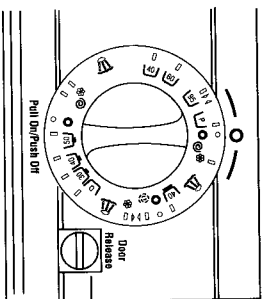

Programme Selector

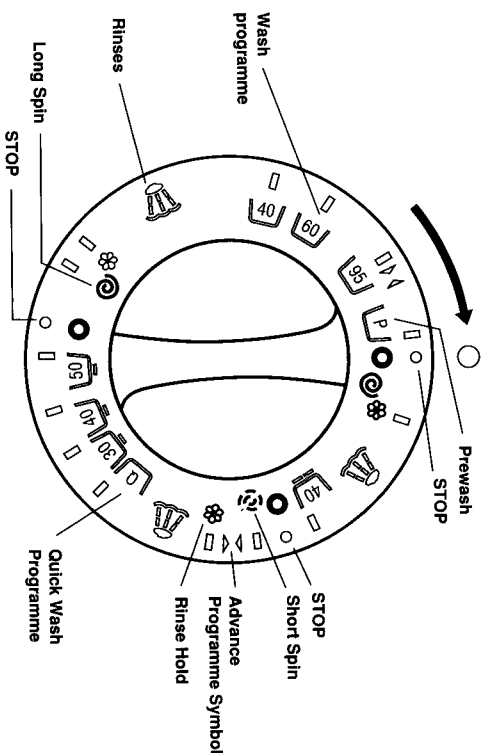

WARNING: CHILDREN SHOULD NOT BE ALLOWED TO PLAY WITH THE APPLIANCE OR TAMPER WITH THE CONTROLS.

Know Your Machine



How to do a wash

BEFORE THE WASH

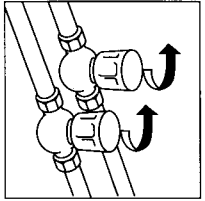

1. Turn on hot and cold water
Hot water should ideally be at 60°C (140°F) and must not be above 70°C (160°F).

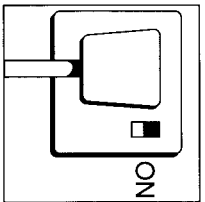

2. Plug in, switch on electricity

WARNING: ENSURE HANDS ARE DRY.

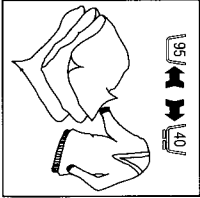

3. Sort your laundry
See page 6
Make up a load of similar fabrics

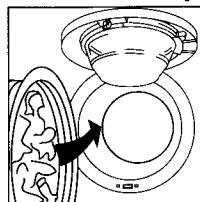

4. Load the machine
See page 8
Don't overload the machine

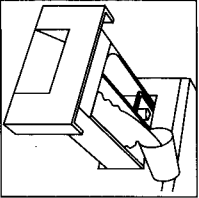

5. Detergent and fabric conditioner
See pages 9 and 10

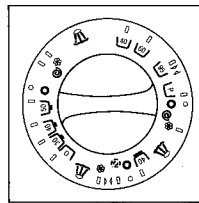

6. Select a programme to suit your laundry
See page 10

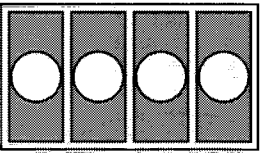

7. Select optional wash features
See page 12

Rinse Hold
Super Rinse
Energy Save
Economy Wash

Stops the machine during the final rinse (progs 50, 40, 30 and 2 only).
Increases water level for deeper rinsing, use with heavy soiled clothes or if people have sensitive skins
Reduced temperature wash
'No heat' wash for light soiling only

<i>The door won't open</i>	Has the door lock been set, see page 12. Is the door locked? Has the programme finished? Could it be on Rinse Hold? Is there water still in the machine? Check your drain outlet and waste pipe connections. If your waste installation is wrong, water could be running back into the machine causing the door to lock! Spin out and try again. Emergency door opening procedure is explained on page 18.
<i>The clothes are not dry enough</i>	Did you select the right programme for the type of fabric? Did the water pump out? (Check waste plumbing arrangements.)
<i>Machine takes a long time</i>	Have you selected a hot wash? See page 13. Hot programmes can take a long time, especially if the water has to be heated up from cold. Other things that can lengthen the programme are: – Prewash – Low water pressure – Modifying your machine to cold fill only
<i>The clothes are not clean</i>	Did you select the correct programme? (Try a prewash next time and the correct wash programme.) Did you use the correct quantity of detergent? (See page 9.) Did you use the Economy Button? Did you select the correct wash options? Was the machine overloaded? Good wash results are only obtainable with the recommended wash load.

IF YOU INSTALL YOUR MACHINE CORRECTLY AND FOLLOW THE USER INSTRUCTIONS SUPPLIED, YOU ARE UNLIKELY TO EXPERIENCE DIFFICULTIES.



It's stopped in mid programme

After the initial fill, the machine may sometimes pause while the heater comes into operation. It should continue after the selected temperature is reached.

Has it stopped on RINSE HOLD? If so, press the button to continue the programme.

NOTE: The Rinse Hold light (if fitted) only operates when the Rinse Hold feature is reached in the programme.

Steam is coming out of the detergent dispenser drawer

During HOT washes the machine is designed to vent steam from the dispenser drawer and this is quite normal.

Water flowing into the machine and out of the drain hose at the same time

Is the drain standpipe at least 500mm (20in) above floor level? See Installation Instructions booklet.

Has the drain hose been pushed down the standpipe more than 50mm (2in)? If so, then raise it.

Suds are coming out from the detergent dispenser

Did you use the right quantity of **LOW SUDS AUTOMATIC DETERGENT**?
Select a rinse programme and flush the machine through.

It makes a noise or vibrates during spin

Your Automatic will make some noises, especially while spinning. **If vibration is excessive, check that you have removed the transit packing. See Installation Instructions.**

Small loads of heavy or bulky items (towels, bath mats, jeans, etc) can cause out of balance conditions but the machine will usually sort itself out.

Check also that your machine is resting firmly on the floor. See Installation Instructions regarding levelling of the machine.

Note: Rattling and scraping noises are not normal and may need attention!

It won't pump out

Has the drain hose been installed correctly? (See the Installation Instructions.) Is the hose kinked? If you have connected to a sink waste spigot, is the spigot blocked?



8. CLOSE THE DOOR SAFETY LOCK

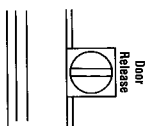

It is recommended that the door is locked if children are nearby. To lock, turn the slot 90° in a clockwise direction.

For safety reasons with or without the lock the door cannot be opened whilst the drum is rotating or contains water.

DURING THE WASH

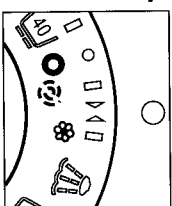

Rinse hold
(Programmes 50', 40', 30' and 0').
See page 13

9.

Start the machine
See page 10

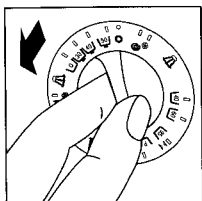

Pull out the Programme Selector. The machine will automatically carry out the programme selected.

If selected with programmes 50', 40', 30' or 0' the machine will stop at this symbol during the final rinse. To continue, release Rinse Hold button. See page 12.



AFTER THE WASH

11. Switch off machine

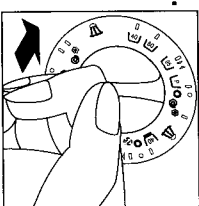

Push in the Programme Selector when programme has finished

12.

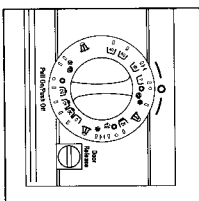

If applicable: Unlock door release button. Press the Door Release button.
Take out laundry

13.

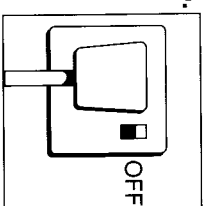

Switch off electricity

14.

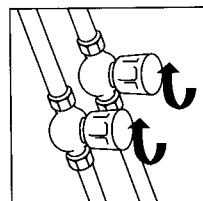

Turn off water

WARNING: WHEN SWITCHING ELECTRICITY OR MACHINE ON OR OFF, PLEASE ENSURE THAT YOUR HANDS ARE DRY.

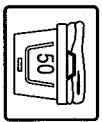

Sorting your laundry

Wash codes appear on the labels on most washable items. You may have some items with the old wash code printed on the garment label. For easy reference, the new and old wash codes are shown below. The new codes are shown on your Programme Selector.

New	Old	Fabric	Energy Wash Maximum		
			Save °C	Temp °C	Full Load
95	95	White cotton and linen without special finishes	80	90	5kg 11lb
60	2	Colourfast cotton, linen or viscose without special finishes	50	60	5kg 11lb
50	4	Coloured nylon polyester acrylic/cotton mixtures, cotton or viscose with special finishes (eg. drip dry), coloured polyester/cotton mixtures	40	50	3kg 6.6lb
40	5	Non-colourfast cotton, linen and viscose	30	40	5kg 11lb
40	6	Acrylics, acetates and tri-acetates, blends of these fabrics with wool, polyester/wool blends	30	40	3kg 6.6lb
40	7	Woolen blankets, wool mixtures with cotton or rayon, silk	30	40	2.7kg 6lb Wash blankets singly
40	7	Shrink resistant machine-washable and Superwash Woolmark garments	30	40	1.4kg 3lb
30	8	Silk and printed acetate fabrics with colours not fast at 40°C	20	30	1.8kg 4lb
Q		Lightly soiled items (not wool – machine washable; wool mixtures)	No Heat	No Heat	0.9kg 2lb

It is advisable to separate light and dark colours. There are often other symbols on the garment label also. These are explained on the opposite page.

If you think you have a problem . . .



Look at this list, then check the adjacent suggestions. They may give you the answer to your problem, without having to telephone your Hotpoint Service Office.

If you cannot solve the problem, follow the advice given on page 18.

Problem	Check these things first
<i>Powder dispenser drawer won't close properly</i>	Ensure flap is fitted correctly. See page 14. Is the drawer jammed with detergent?
<i>It won't start</i>	Have you selected the programme and pulled out the selector knob? Is the loading door closed firmly? Is it plugged in and switched on at the mains? Is the socket OK? (Try another appliance in it.) Has the fuse blown? (Try a new fuse of the correct rating.)
<i>It won't fill or take in the detergent</i>	Are the taps turned on fully? Are the fill hoses kinked behind the machine? Have you got the hoses connected correctly. See page 2. Have you selected the programme correctly and pulled out the selector knob to start the machine? If you have a liquid detergent dispenser – did you put powder in the liquid detergent dispenser by mistake?
<i>The programme sticks at the end of the wash or during the rinses</i>	Has the drain hose been installed correctly? If not, syphoning could occur and this will halt the programme. Check the installation instructions. It is important that you do not remove hooked end support and push the hose too far down the waste standpipe.
<i>It's leaking</i>	Are the fill hoses tightened correctly? – Perhaps the washers are not sealed properly. Is your standpipe blocked? Is your household drainage system blocked? If you cannot clear the blockage yourself, you will need a plumber. Removal of the hooked end support may cause a leakage.



Caring for your machine

- When programme has finished:**
- press in the Programme Selector
 - cancel any feature buttons.

- After each wash:**
- open door, remove clothes and rotate drum to check for small items left behind.
 - remove dispenser drawer for cleaning:

- To clean dispenser:**
1. Pull out the drawer until it reaches its stop, then lift slightly and give it a sharp tug to remove it completely (see diagram).

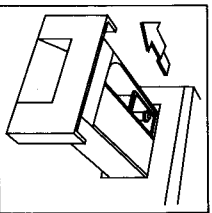

2. Remove fabric conditioner compartment.
 3. Pull off syphon tube and clean conditioner compartment.
 4. Push syphon tube **firmly** back into place in the conditioner compartment.
 5. Clean the dispenser drawer and dry thoroughly.
 6. Replace the conditioner compartment in the dispenser drawer, with the syphon tube towards the back.
 7. Check that the flap at the back is in place and pivots correctly.
- To locate drawer into the machine, hold the top of the flap away from you until it locates under the top of the dispenser opening, then push the drawer back in firmly.

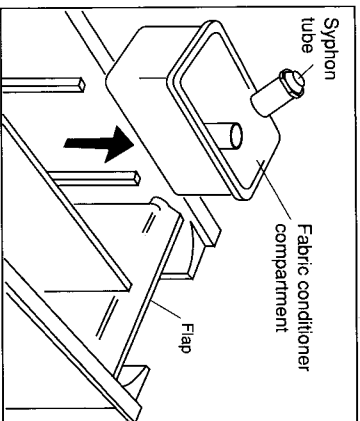

As necessary

Clean exterior surfaces with a damp cloth or silicon polish only.

Do not use abrasive cleaners, scouring agents, acids, chlorine bleach or metal polish to clean any part of the machine. This could damage it.

Yearly. We recommend you take out a Hotpoint Service Cover Plan with annual safety/maintenance check which ensures the machine is professionally serviced every year. Details are given at the end of this book.

Hotpoint strongly recommends that its machines are regularly checked for electrical and mechanical safety whether or not they are covered by a Hotpoint Service Cover Plan. This is to avoid such things as worn door gaskets or hoses which may cause a leak on a machine which could become dangerous if neglected.

NOTE: The hole in the door gasket is designed to help water drain into the drum.

WASHING:

- Hand wash only.
- Do not machine or hand wash

Dry Cleaning:

- All of these are dry cleaning symbols. The letters are to instruct the cleaner what type of solvent should be used.
- Garments bearing these symbols should not be washed in your machine, unless the label says otherwise.**
- Do not dry clean.

Bleaching:

- Bleach may be used. In this case the letters 'Cl' show that a chlorine household bleach such as 'Domestos' can be used. NB This applies to hand washing only. **Do not use bleach in your machine.**
- Do not bleach.

NOTE: Do not wash non-colourfast items, woollens or really dirty clothes in a mixed load.

Woollens

Machine-washable woollens may be washed on programme but remember:

1. Limit the load to 1.4kg (3lb).
2. Do not use a Prewash (soaking may harm woollens).
3. Do not tumble dry.

Do not machine wash woollens which don't have a Washcare label or any label stating they are machine washable.

NOTE: Some 'woollens' are not made of wool at all but acrylic, which should be washed on programme . Check the label to make sure.

Pre-treating dirt and stains

Brush a little washing detergent dissolved in water onto stains like collars and cuffs to help shift the dirt.

Treat stains immediately

Plunge the stained area into **cold** water, or sponge it down. This prevents the stain from setting. Wash as soon as possible afterwards.

Nappies: Scrape off any excess baby cream, such as Vaseline[®] from the nappies before washing. Use a Prewash programme (page 11) to prevent the cream being transferred to other items in the wash.

Pockets and Zips

DO MAKE SURE ALL YOUR POCKETS ARE EMPTY.

Tissues can disintegrate and cover all your washing.

Sharp objects like coins and keys can damage clothes and the machine.

Close all zips and tie belts and strings to prevent tangling.



Sorting Your Laundry



Load your machine

Don't overload your machine.

Clothes won't wash properly and damage may be caused to your machine and garments. See page 6 for maximum wash loads.

Typical Weights

To help you wash the correct quantity of clothes, the chart below lists typical clothes weights.

Clothes	Weight		
Blouse	Cotton	150g	5oz
	Other	100g	3½oz
Dress	Cotton	500g	1lb 2oz
	Other	350g	12oz
Jeans		700g	1lb 8oz
10 Nappies		1000g	2lb 3oz
Shirt	Cotton	300g	10½oz
	Other	200g	7oz
T-Shirt		125g	4½oz
Household items			
Duvet Cover (Double)	Cotton	1500g	3lb 5oz
	Other	1000g	2lb 3oz
Large Tablecloth		700g	1lb 8oz
Small Tablecloth		250g	9oz
Tea Towel		100g	3½oz
Bath Towel		700g	1lb 8oz
Hand Towel		350g	12oz
Double Sheet		500g	1lb 2oz
Single Sheet		350g	12oz

Additional tips:

- Blankets, double bedspreads and other bulky articles should be washed one at a time.
- To load a blanket, hold it by the centre and allow the corners to drop down. Feed it into the machine centre first.
- Highly absorbent loads such as towels and nappies should be limited to 3kg (7lb) per load to ensure adequate rinsing.
- Place small items in a washbag.
- Check the wash symbol on items such as T-Shirts. They may require a cool wash eg.
- Whenever possible wash a full load of clothes to obtain maximum cost and time efficiency.**

The machine at work

Your Aquarius washing machine has been designed to use the minimum amount of water for economy, do not worry if you notice less water in the drum than your previous machine.

What's it doing?

During use you will be aware that your machine will be making some noise and will stop at various intervals during the programme. This is normal. During the wash the machine will:

- Fill** with water, tumbling to mix the detergent.
- Heat** to temperature, with the occasional tumble. This may take some time, so don't be worried if it appears to have stopped working.
- Wash** the clothes, by tumbling, stopping and reverse tumbling.
- Cool rinse.** On programmes , and , the first rinse has a stepped 'cool down' feature by which cold water is added to the hot wash water to gradually reduce its temperature and prevent shock creasing of the washing.
- Dispense fabric conditioner.** If added, this is dispensed on the final rinse.
- Rinse Hold.** Machine stops on the final rinse on programmes , , and , if you've pushed in the Rinse Hold button (see page 12). Push Rinse Hold button to restart programme.
- Spin.** Follows each rinse at one of two different speeds.

WARNING: IT IS POSSIBLE FOR CHILDREN AND ANIMALS TO CLIMB INTO WASHING MACHINES AND INJURE THEMSELVES.



How long can programmes take?

It depends on many things for example:

- Water flow rate.
- Temperature of incoming water.
- Time taken for machine to heat up the water.
- Features selected.
- Type and weight of clothes load.

The approximate programme times are:

Programme	Approximate time	
		115-120 mins
		85-90 mins
		60-65 mins
		65-70 mins
		45-50 mins
		40-45 mins
		35-40 mins
		30-35 mins

Prewash adds 20-30 minutes.

Economy Wash saves up to 15 minutes.

WARNING: DO NOT TOUCH THE GLASS DOOR WHEN THE MACHINE IS IN OPERATION AS THIS AREA CAN BECOME HOT.

The Machine at Work



Additional Wash Features

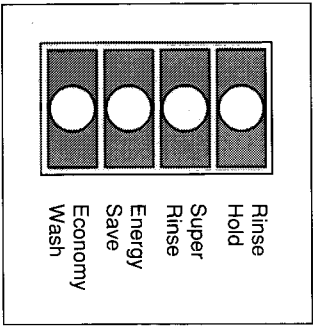

One or more option buttons can be pressed in to give you the versatility of wash programme you require.

Select your own wash option BEFORE pulling out the Programme Selector. Press button(s) again to cancel option.

Rinse Hold
minimises creasing of synthetic fabrics

Programme stops at final rinse with washing immersed in water until they are spun dry.

Press Rinse Hold button to complete programme.

Super Rinse
By pressing this button the amount of water used for rinsing will increase.

Energy Save
For a reduced temperature wash.

By selecting Energy Save you reduce the temperature of the wash, for example a 60 programme would wash at 50, thus saving time and electricity. Use Energy Save for normal or lightly soiled clothes, not for really dirty clothes

Economy Wash
For lightly soiled washing; saves electricity and time.

Economy Wash switches off the machine's own water heater so your clothes are washed at the temperature of the water entering your machine from the hot and cold water supply. This saves you electricity, but means a cooler wash. Use Economy Wash for lightly soiled clothes, not for really dirty clothes.

PULL OUT PROGRAMME SELECTOR TO START THE MACHINE.

DON'T FORGET TO CANCEL BUTTONS AT THE END OF THE PROGRAMME.

Additional Features

Safety Lock
If children are nearby it is recommended that the door is locked. To lock, turn the slot 90° in a clockwise direction. To unlock turn 90° in an anti-clockwise direction.

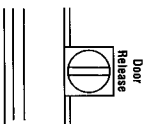

Washing Detergent

Which one to use?

Use any low suds automatic powder. Non-automatic powders reduce wash performance and can cause overfoaming.

Your machine has been specially developed to take advantage of biological powders. Hotpoint recommends Biological Persil Automatic.

How much to use

It is important to use the correct quantity in soft or hard water areas: too little won't get the clothes clean, and too much is a waste.

In soft water you will not need to use the total quantity supplied in the trial sample packed in the drum.

Quantities indicated below apply to Persil Original Automatic Powder.

For other detergents refer to the packet.

The Aquarius range of washing machines have been designed to use less detergent and water. The table below will give you a guide which if necessary you can amend in the light of your own experience.

Detergent	Cottons Hard water/ Soft water*	Synthetics Hard water/ Soft water*	Woollens Hard water/ Soft water*
Prewash	75/50 grams	75/50 grams	-
Full load	180/140 grams	110/80 grams	110/90 grams
Reduced load	120/80 grams	90/70 grams	90/70 grams

These doses are for normally soiled loads
1 cup = 265ml = approximately 160g.

*If you are unsure, check with your local water company.

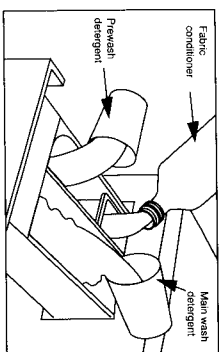

Where to put it

Pull-out drawer on the left of the machine. Powders or liquids which cannot be dispensed through the drawer should be used in detergent dispensers as recommended by the detergent manufacturer, whose instructions on use and quantity of detergents should be followed.

Concentrated detergents

Are now becoming more widely available. Follow the detergent manufacturer's guide regarding quantities to use.

Liquid detergent

To dispense all liquid detergents (which do not require their own dispenser) we recommend using the Hotpoint Liquid Detergent Dispenser (Part No. 9003) which is obtainable from your nearest Hotpoint Spares Centre (see back page) using the order form enclosed. Place the Liquid Detergent Dispenser in the right hand section of the dispenser drawer.

Remove any water remaining from the previous wash before adding liquid detergent and ensure that the syphon tube is firmly in position.

When using liquid detergents in their own dispensers, follow manufacturer's instructions.

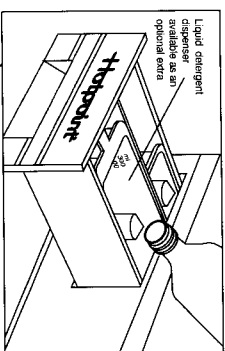

DON'T FORGET TO CANCEL BUTTONS AT THE END OF THE PROGRAMME.

Additional Wash Features



Fabric Conditioner

Hotpoint recommends Comfort. It will soften your washing; eliminate static cling from synthetics and make ironing easier. Add conditioner when adding your detergent. Use the quantity recommended on the bottle. Don't exceed the quantity.
 Remove the fabric conditioner compartment and tip out any water remaining in it before adding conditioner. Replace it as shown with the siphon tube towards the back.

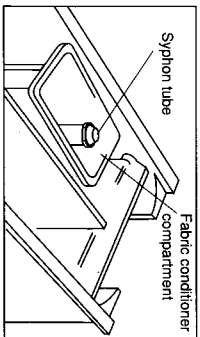

A Lockable Dispenser Drawer

(Part No. 9002) is available, to prevent young children from opening the drawer whilst the machine is running, or from hiding objects in the drawer. This can be ordered from your local Hotpoint Spares Centre (see back page), using the order form enclosed.

WARNING: DO NOT PULL OUT THE DISPENSER DRAWER WHILE THE MACHINE IS OPERATING AS THERE MAY BE HOT WATER PASSING THROUGH IT.



Selecting your Programme

Turn the Programme Selector clockwise to the wash programme according to the clothes label code (see page 6) or one of the alternative programmes on page 11. The symbol selected should be at the top, eg. 50/

Do not turn the Programme Selector anti-clockwise and do not turn it when it is pulled out. Push it in to select another programme.

Select any additional features.
 Pull Programme Selector OUT to start the programme.

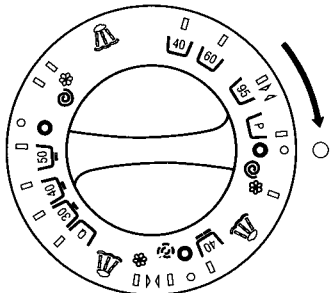

Programme Selector

Do not attempt to open the door once the programme has started

Selecting your Programme

The following additional programmes may be selected.

Prewash

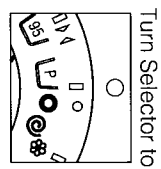

Select Prewash for really dirty clothes, like football kit and nappies. Select Prewash before any programme except 40/.

When finished Programme Selector will stop at the symbol . Push Programme Selector in and turn to select the main wash you want. For a cold Prewash, press the Economy Wash button as well.

Quick Wash

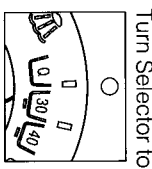

A quick cool wash to freshen up lightly soiled items in just over 30 minutes. Max load 0.9kg (2lb). Not recommended for woollen or machine washable wool.

Spin Only

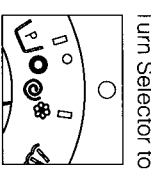

Long Fast Spin
 Natural fabrics— wash codes 95 60 40 40

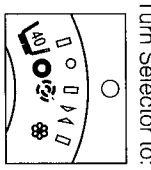

Short Slow Spin
 Synthetic fabrics— wash codes 50 40 30 10

NB: Do not fill more than half full with wet clothes (natural fabrics) or one-third full of synthetics. Short Slow Spin has a burst at high speed at the end of its cycle.

Rinse and Spin

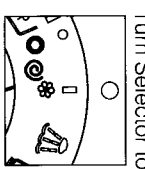

Choose the rinse symbol on the Selector just before the type of spin you want – Long Fast (☺) or Short Slow (☹) to suit the fabric.

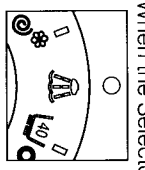

Rinses
 When the Selector reaches: The machine is in its rinse programme.

NB: Woollens and other Hand-Wash only items should only be spin dried, but it is advisable to rinse and spin all other washable fabrics.

End of Programme

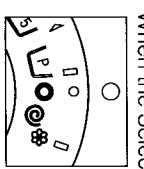

When the Selector reaches: The programme has finished. To switch off, push in the Programme Selector, open the door and remove the clothes.

