

**CITROËN XSARA PICASSO ( '99- )**

**CITROËN BERLINGO ( '96- )**

**PEUGEOT PARTNER ( '96- )**

D8.863 Rev.0 / 2005.10.28

- 
- ✳ **Enganche fabricado por URBENI adaptable a la marca del vehículo.**
  - ✳ **Towbar made by URBENI adaptable to the brand of the vehicle.**
  - ✳ **Attelage fabriqué par URBENI adaptable à la marque de ce véhicule.**
  - ✳ **Für dieses Fahrzeug angepasst und hergestellt durch URBENI**
  - ✳ **Dispositivo de traino URBENI adeguato alla marca di questo veicolo.**

URBENI le ofrece una garantía del producto por un periodo de 2 años desde la fecha de entrega. conforme lo dispuesto en la directiva 1999/44/CE y la ley 23/2003, esta garantía está limitada a reemplazar el producto defectuoso y en ningún caso se extenderá a daños o perjuicios consecuenciales.

THE URBENI's products have a warranty period of 2 years after the delivery date, conform to the standard 1999/44/CE, this warranty is limited to the replacement of the defective products, and it will not never cover any derivate damages.

Les produits d'URBENI ont une garantie de 2 ans depuis la date de livraison ce qui est conforme à la Normative Européenne 1999/44CE. Cette garantie inclue de remplacer le produit défectueux, mais en aucun cas les dommages ou préjudices conséquents

URBENI gewährt eine Garantie von einen 2 Jahre in ordnung nach dem Fertigungsnorm. Der Hersteller behält sich das Recht vor die schadhafte Ware zu repaieren oder zu ersetzen und in keinem Fall übernimmt er Folgekosten für Schäden an Dritten.

Bemerkung: Für einen Mangel am Produkt, der durch den Fahrzeughalter oder eine andere. Person aufgrund unsachgemäßer Benutzung verursacht wurde, übernimmt Urbeni keine Haftung. Alle befestigungsschrauben der KmH nach ca. 1000 Anhänger-Km und bei jeder Fahrzeuginspektion gemäss den angegebenen Anziehdrehmomenten nachziehen

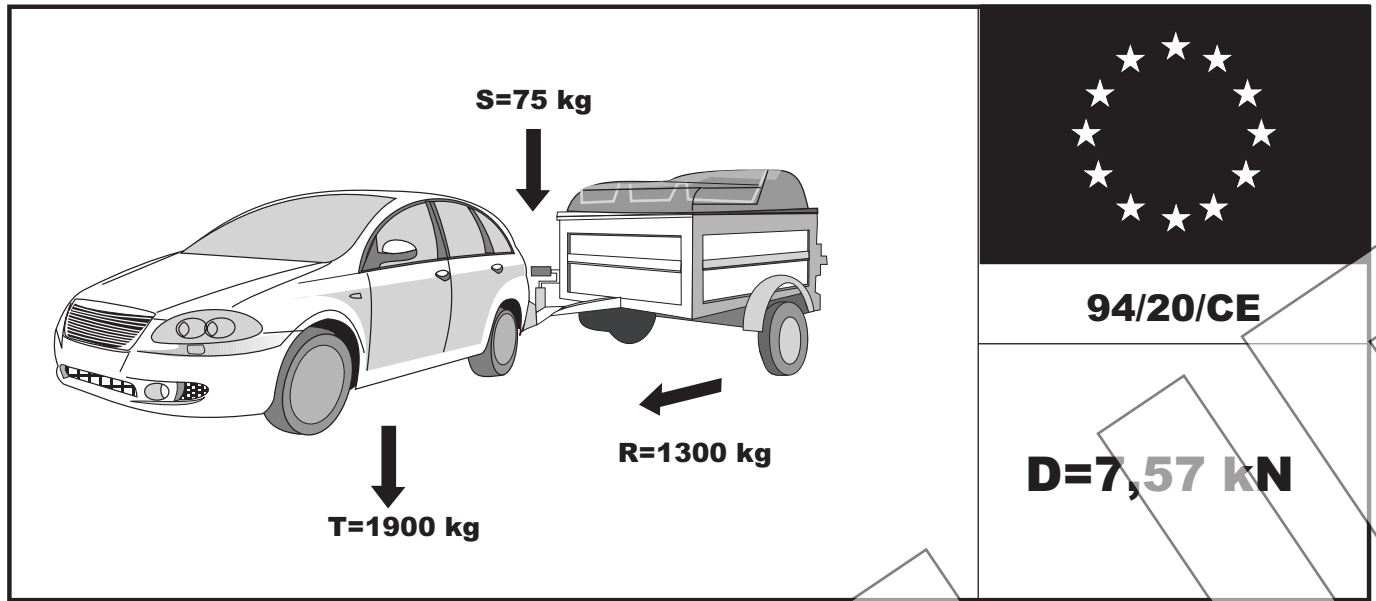

$g = 9,81 \text{ m/sg}^2$

$$D = \frac{T \cdot R}{1000 \cdot (T + R)} \cdot g \quad T = \frac{R \cdot D \cdot 1000}{(g \cdot R) - (1000 \cdot D)} \quad R = \frac{T \cdot D \cdot 1000}{(g \cdot T) - (1000 \cdot D)}$$

kN                      kg                      kg



	<b>M8</b>	<b>M10</b>	<b>M12</b>	<b>M14</b>	<b>M16</b>
<b>N·m</b>	<b>23</b>	<b>50</b>	<b>80</b>	<b>135</b>	<b>200</b>

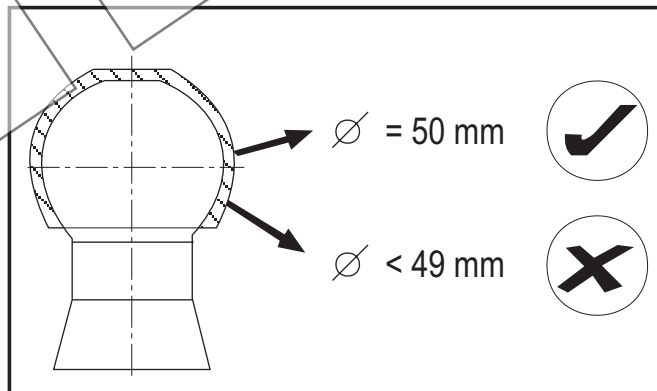

**URBENi**

**75 kg**

**S**

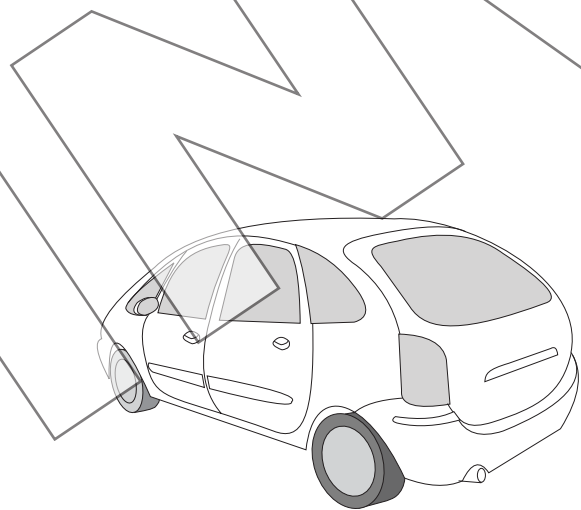
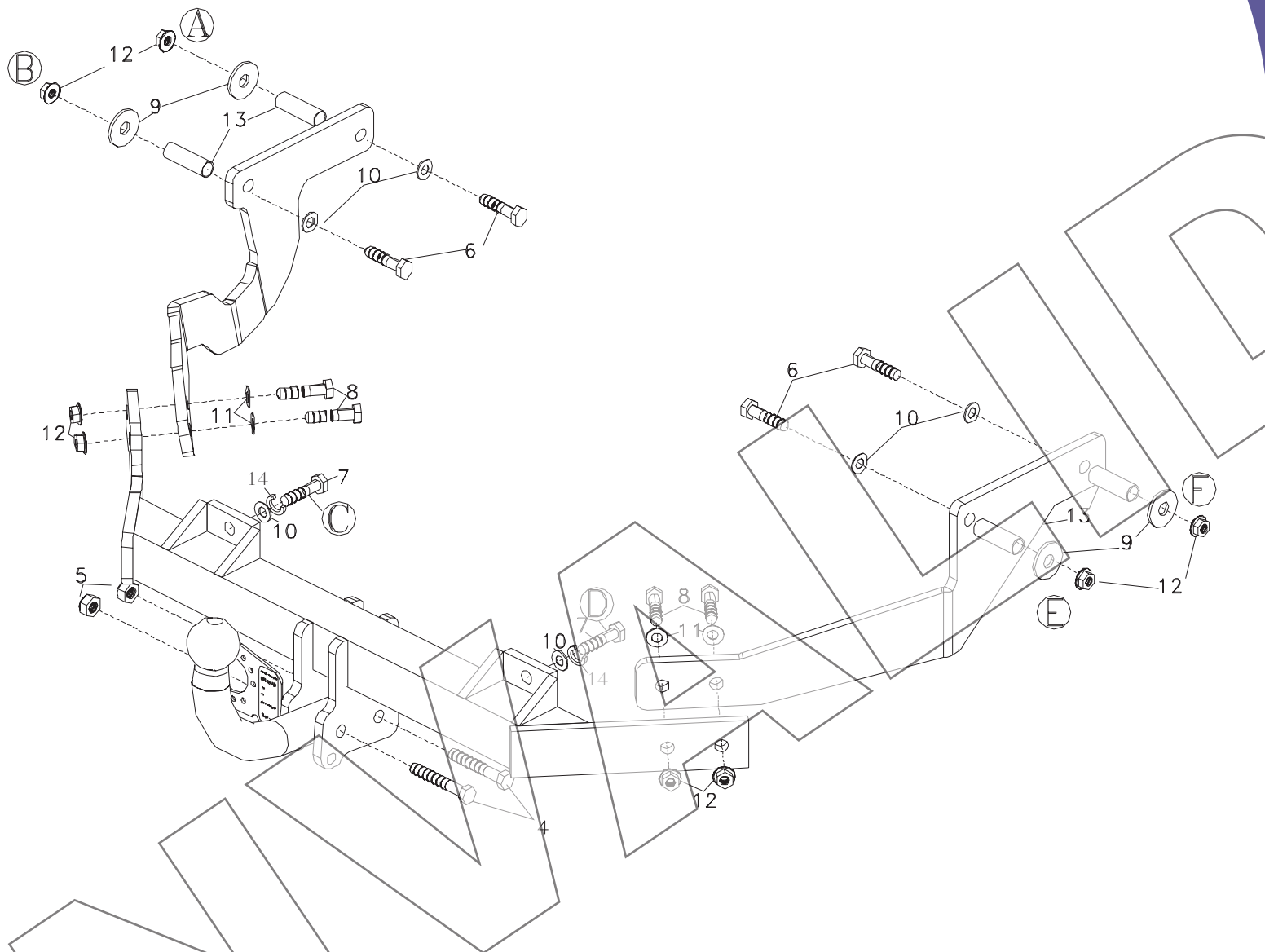

CITROËN XSARA  
PICASSO

REF: 00745

**URBENI**

CLASS **A50-X**

**e13** APPROVAL NUMBER  
**00\*0752**

TYPE **C 016 F**

D-VALUE  
D **7,57** kN

MAX. VERT. LOAD.  
S **75** kg

www.urbeni.com  
MADE IN SPAIN

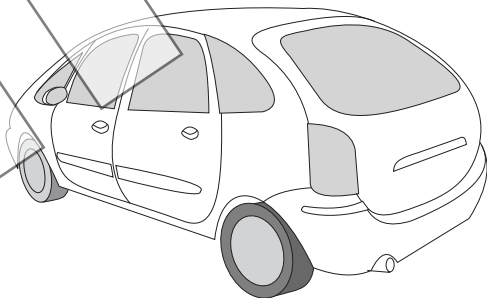
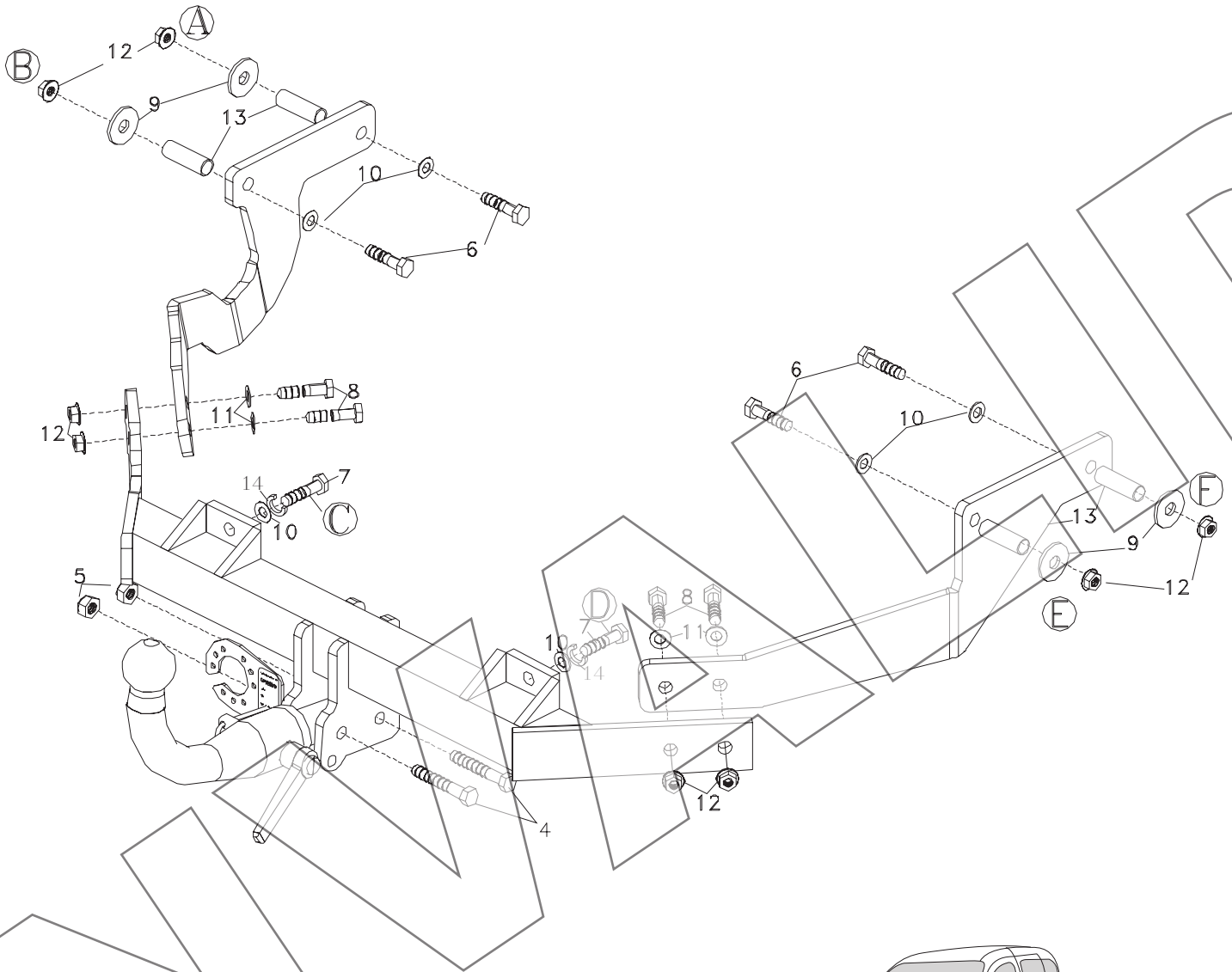

CITROËN XSARA  
PICASSO

REF: 20745

**URBENi**

CLASS **A50-X**

**e13** APPROVAL NUMBER  
00\*0752

TYPE **C 016 FD**

D-VALUE  
D **7,57** kN

MAX.VERT.LOAD.  
S **75** kg



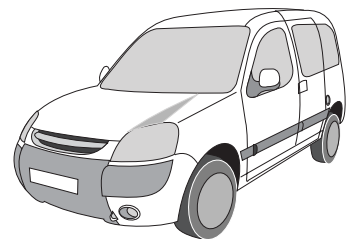



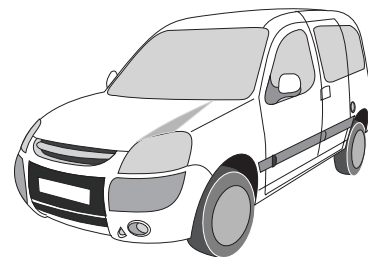



www.urbeni.com  
MADE IN SPAIN

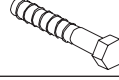
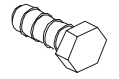
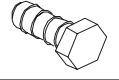

CITROËN BERLINGO

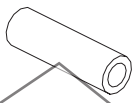

PEUGEOT PARTNER

N°		Q	
1		1	
2		1	
3		1	
6		4	M10x90 DIN 931
7		2	M12x30 DIN 933
8		4	M10x40 DIN 933
9		4	M10 DIN 9021
10		6	M12 DIN 125
11		4	M10 DIN 125
12		8	M10 DIN 6923
13		4	DIAM. 14x50 mm.
14		2	M12 DIN 7980
			
4		2	M12x80 DIN 931
5		2	M12 DIN 985

1

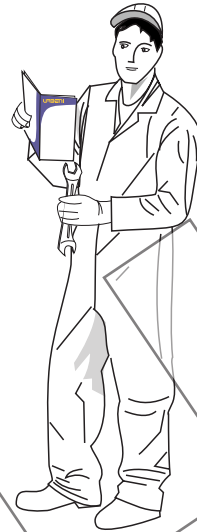
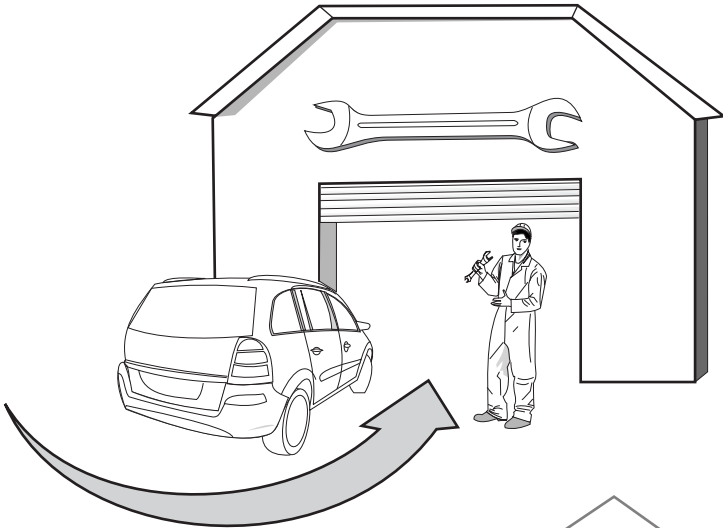

2

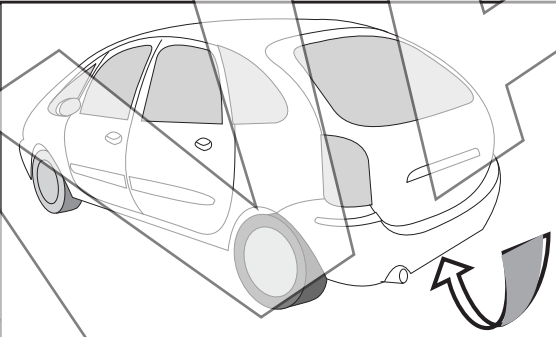

CITROËN BERLINGO  
PEUGEOT PARTNER  
CITROËN PICASSO

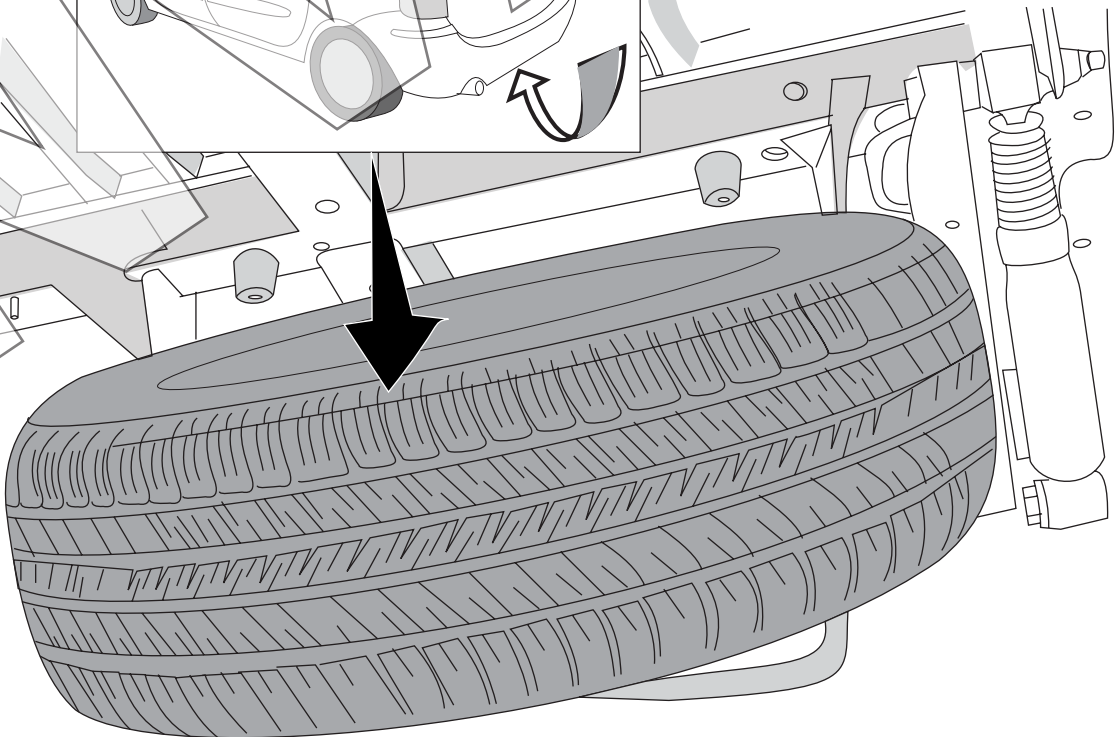

3

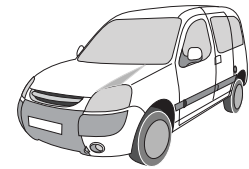
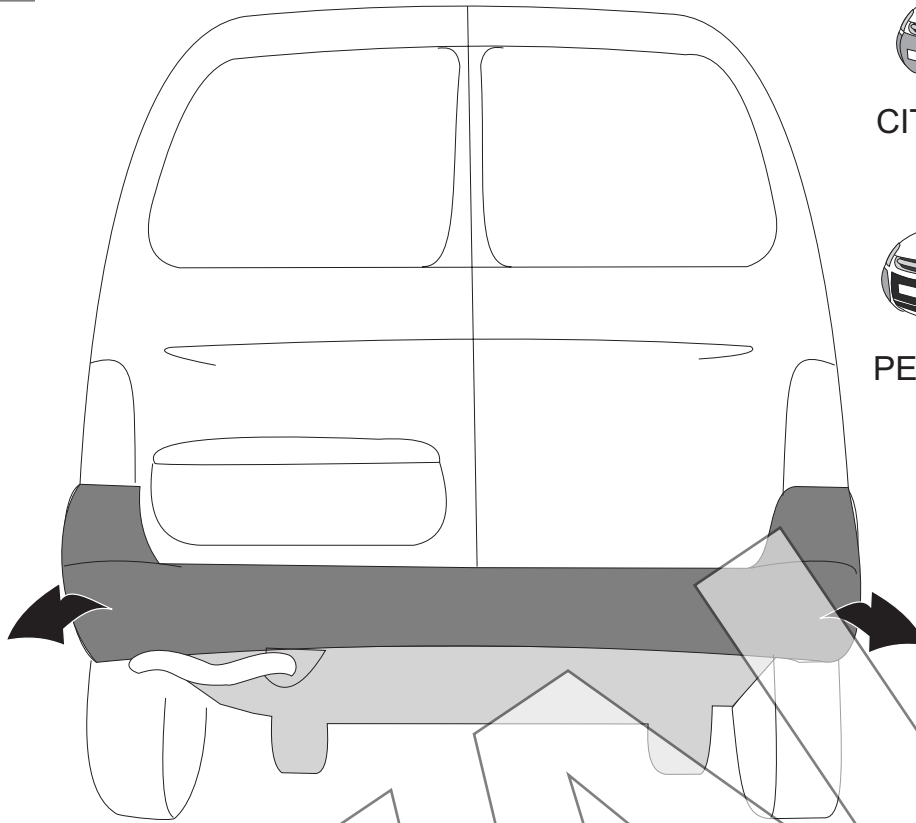

CITROËN BERLINGO



PEUGEOT PARTNER

4

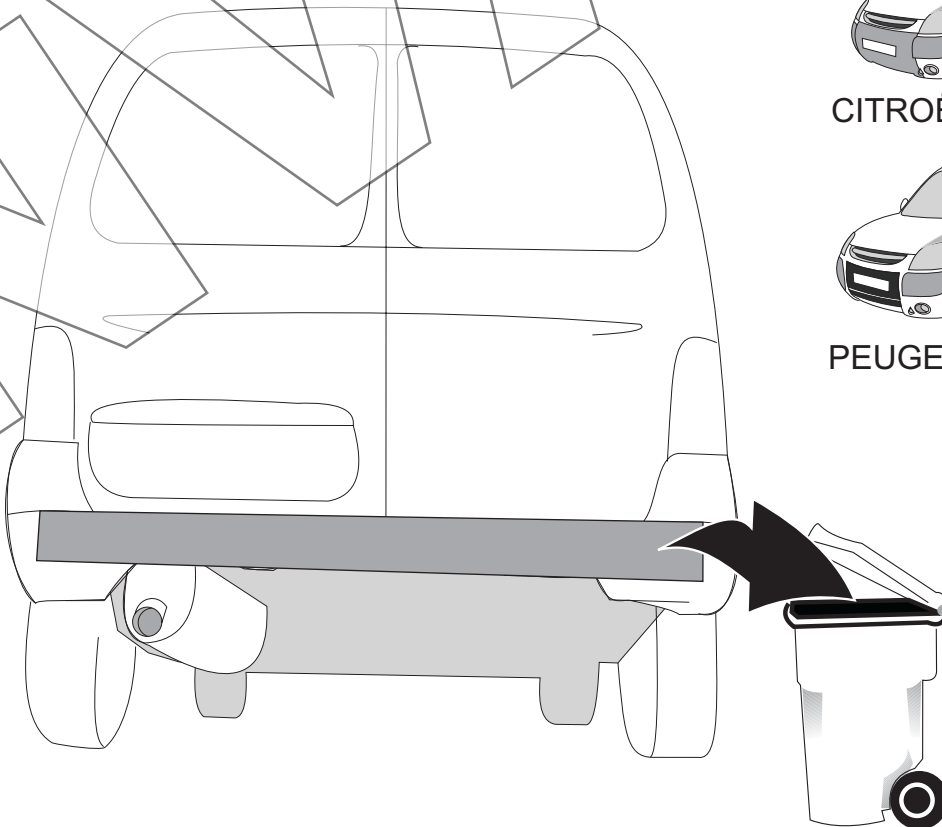

CITROËN BERLINGO



PEUGEOT PARTNER



5

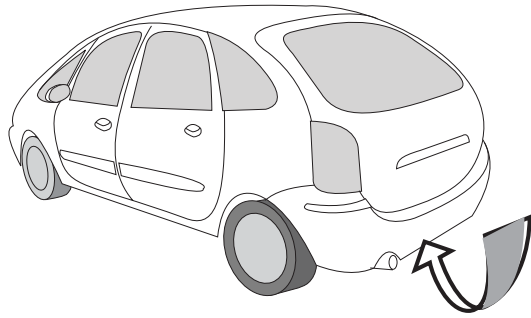

CITROËN BERLINGO  
PEUGEOT PARTNER  
CITROËN PICASSO

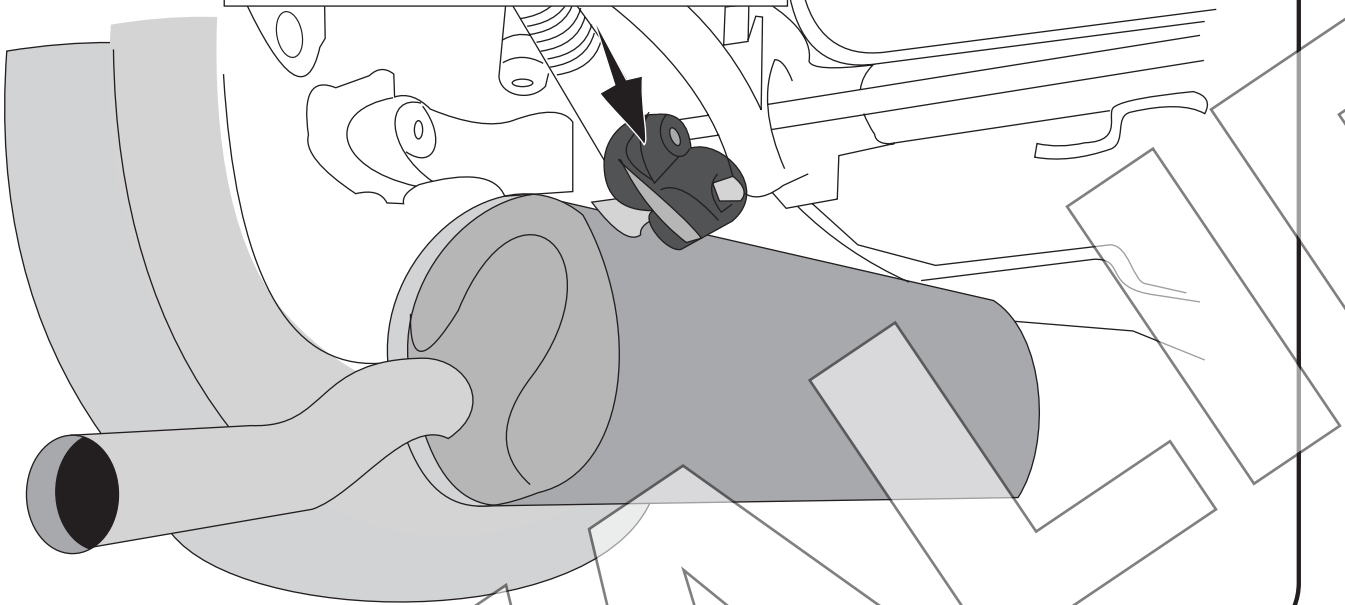

6

CITROËN BERLINGO  
PEUGEOT PARTNER  
CITROËN PICASSO

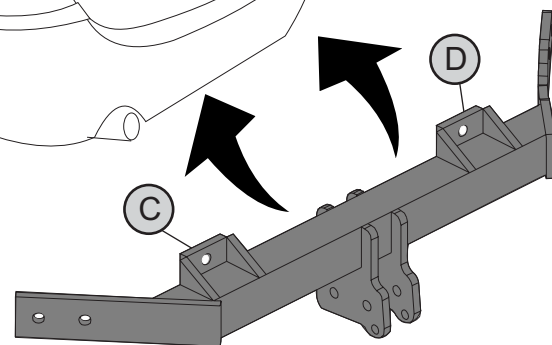
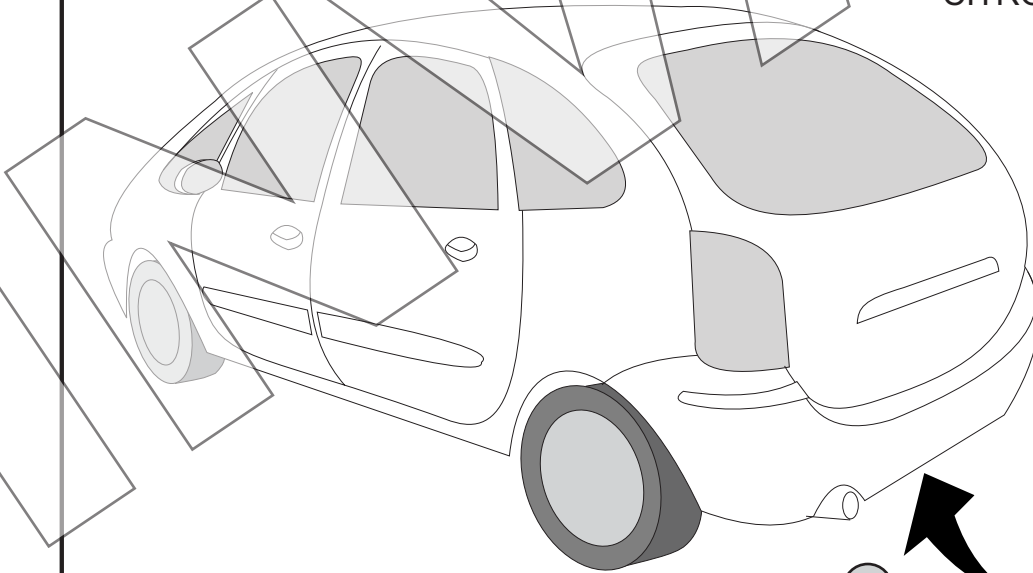

7

CITROËN BERLINGO  
PEUGEOT PARTNER  
CITROËN PICASSO

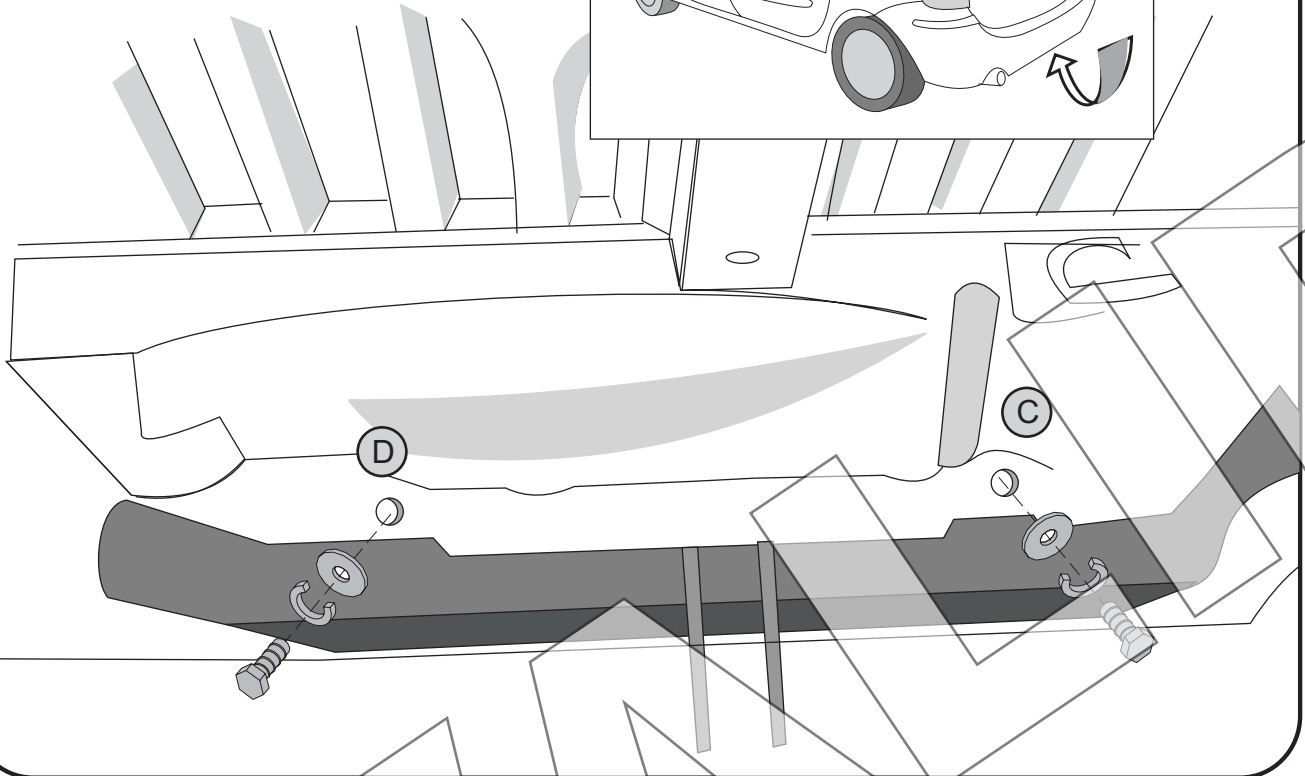
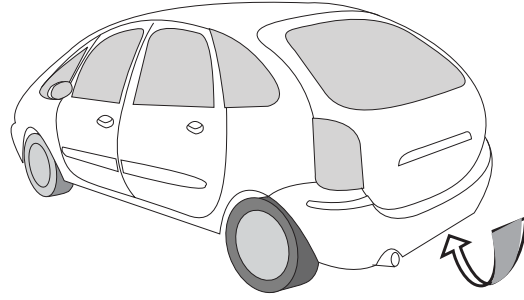

8

CITROËN BERLINGO  
PEUGEOT PARTNER  
CITROËN PICASSO

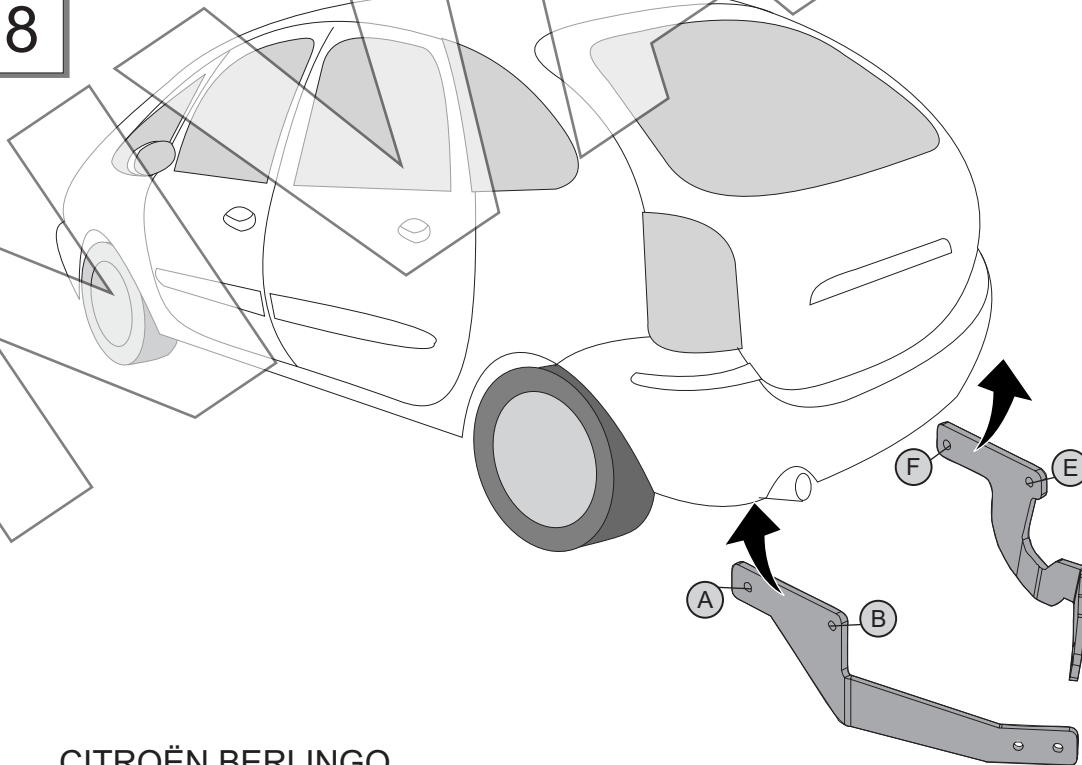

9

CITROËN BERLINGO  
PEUGEOT PARTNER  
CITROËN PICASSO

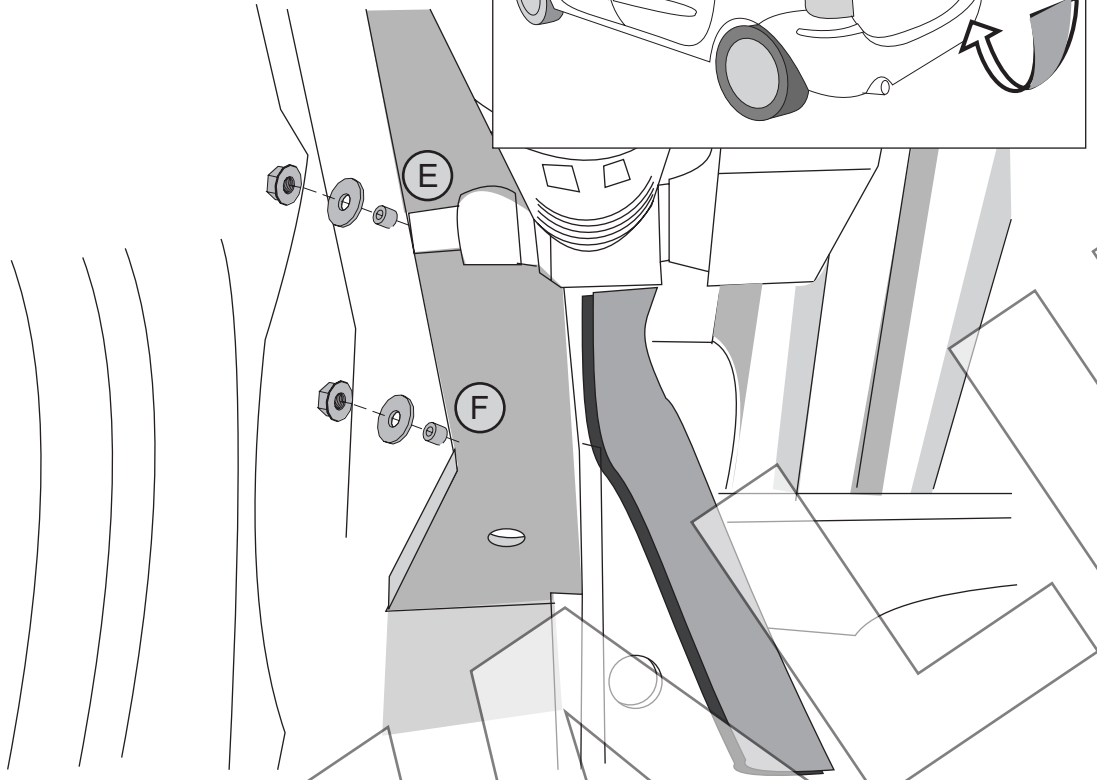
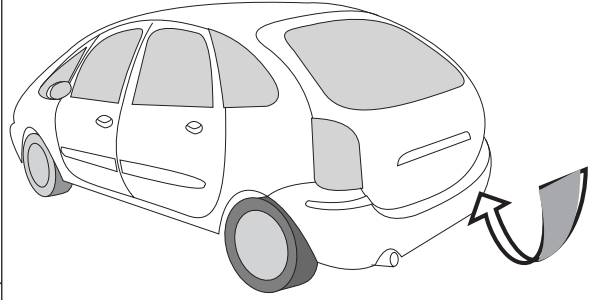

10

CITROËN BERLINGO  
PEUGEOT PARTNER  
CITROËN PICASSO

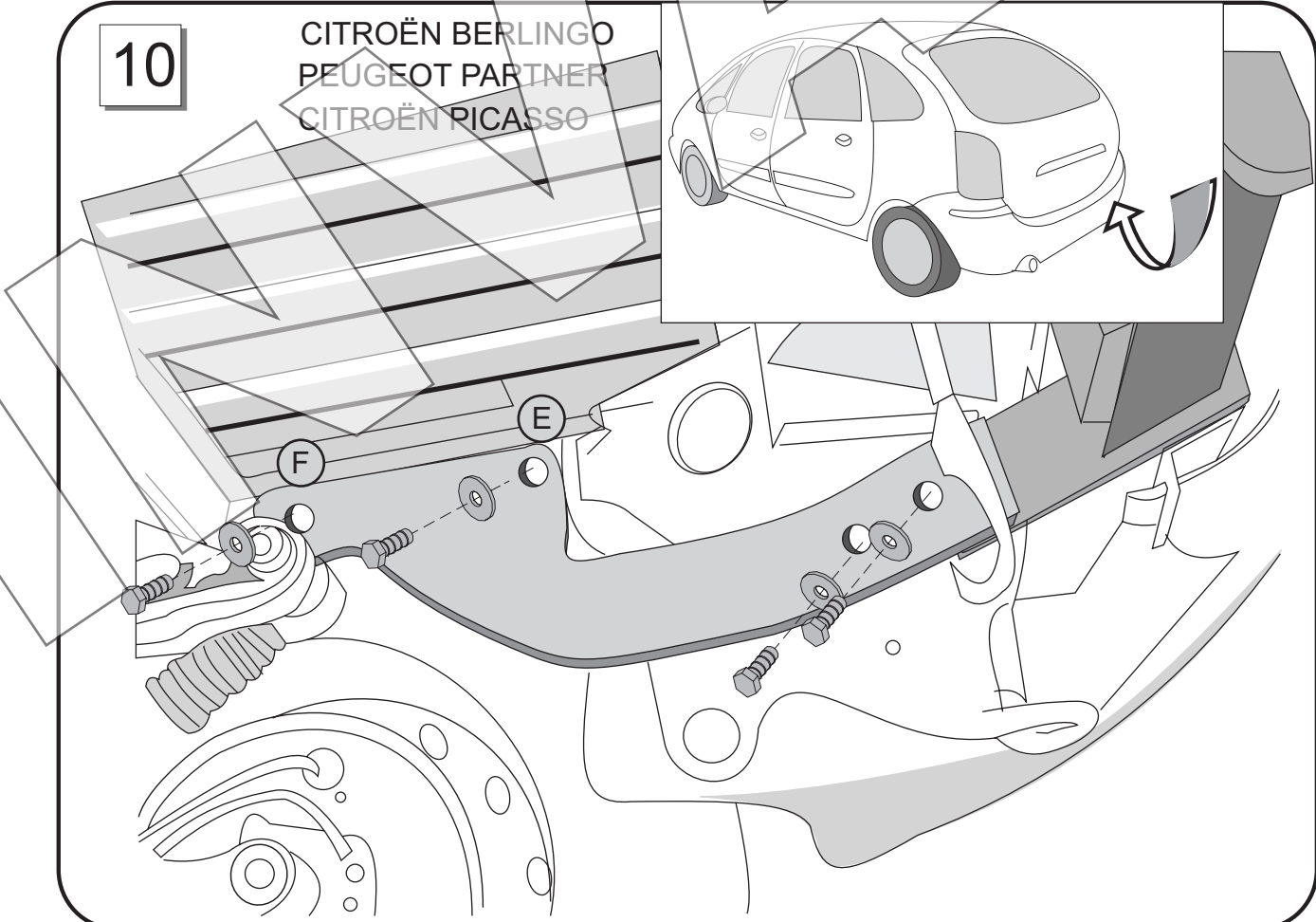
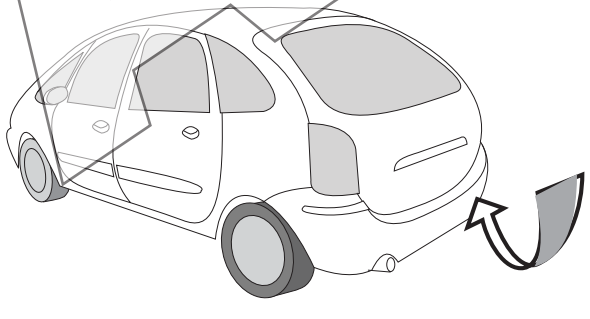

11

CITROËN BERLINGO  
PEUGEOT PARTNER  
CITROËN PICASSO

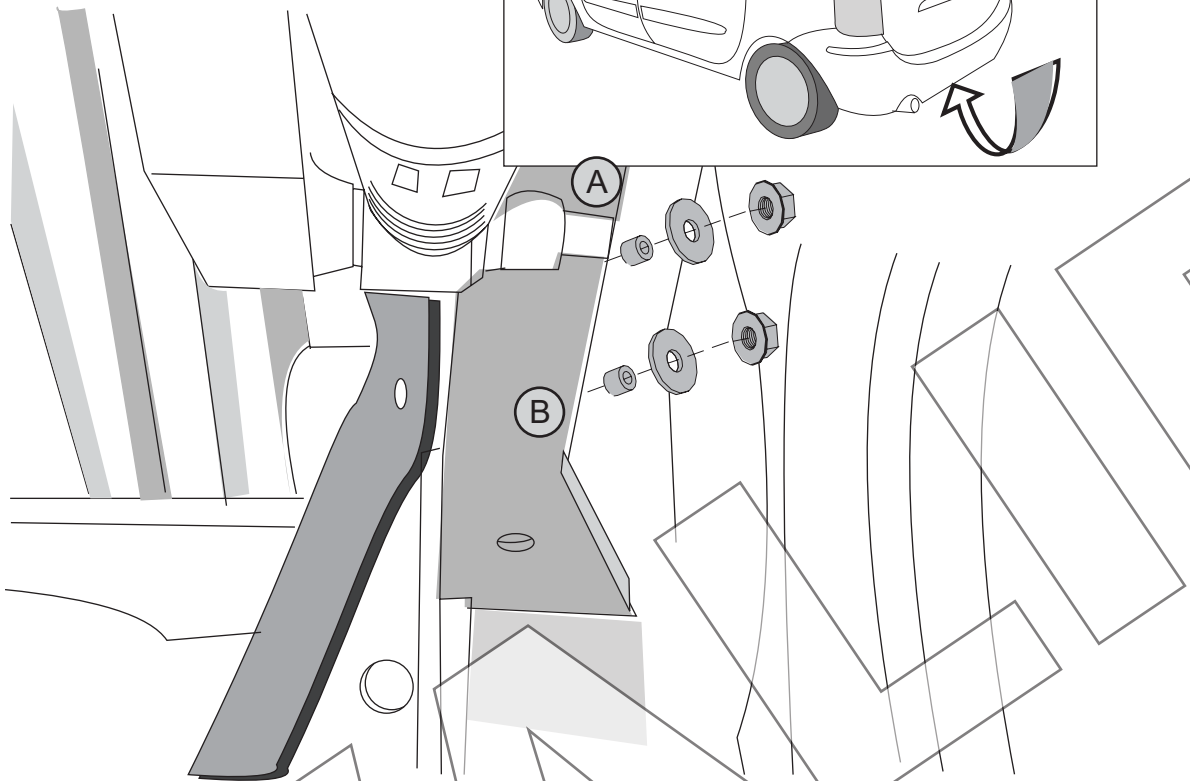
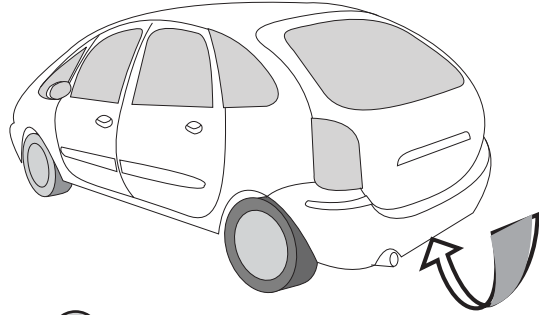

12

CITROËN BERLINGO  
PEUGEOT PARTNER  
CITROËN PICASSO

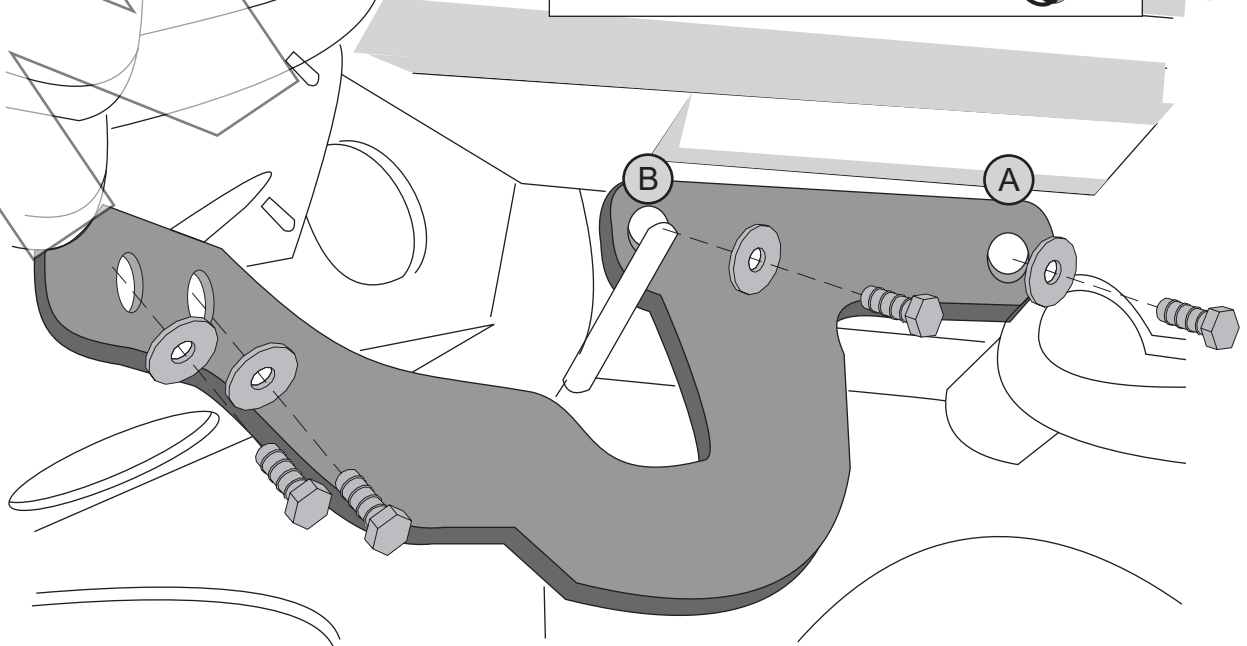
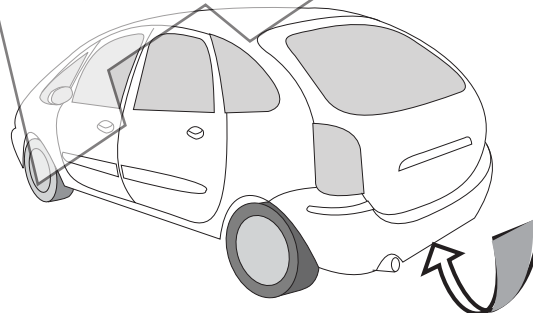

13

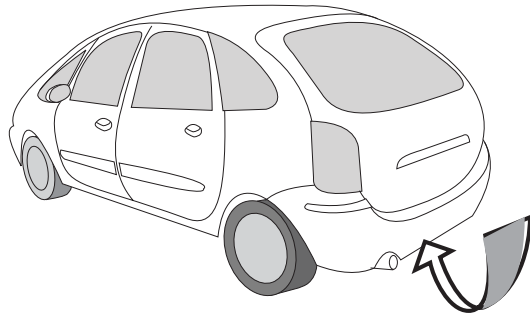

CITROËN BERLINGO  
PEUGEOT PARTNER  
CITROËN PICASSO

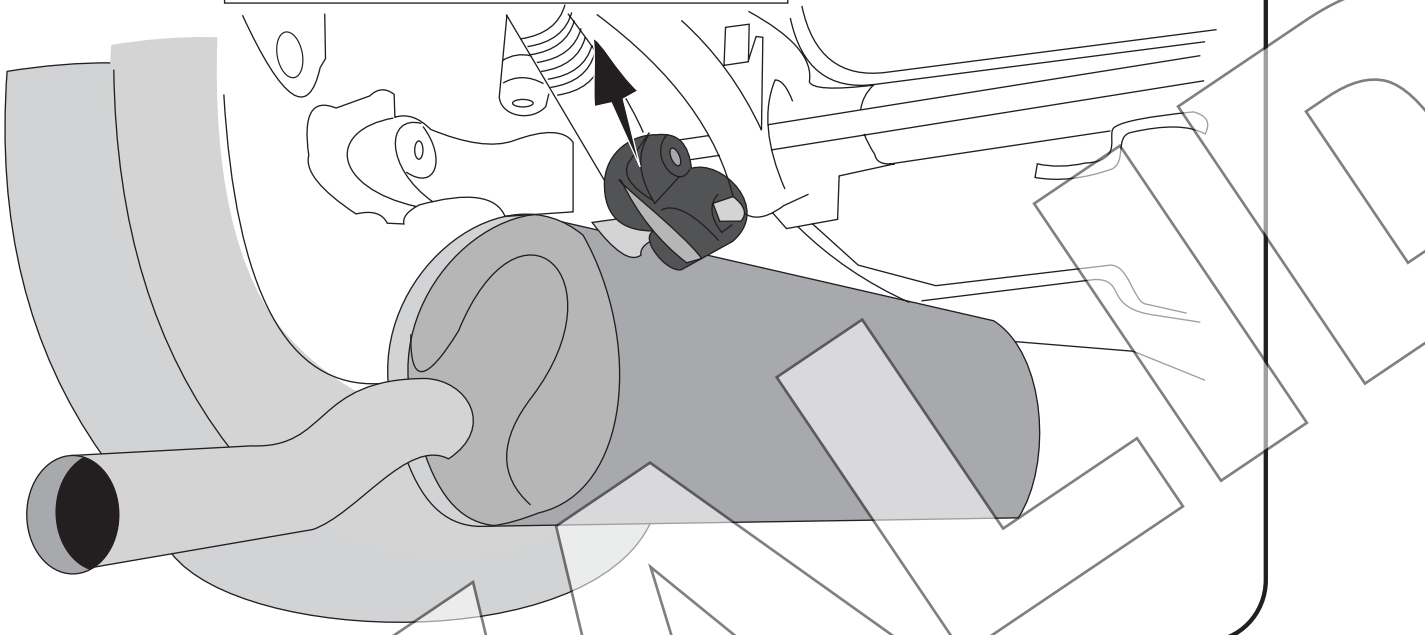

14

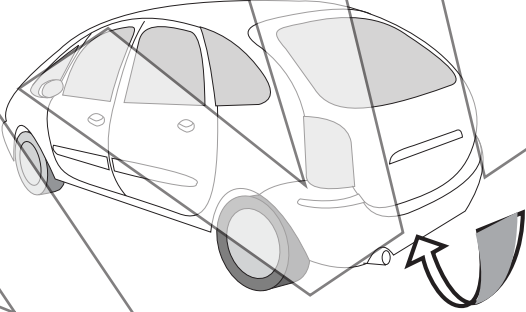

CITROËN BERLINGO  
PEUGEOT PARTNER  
CITROËN PICASSO

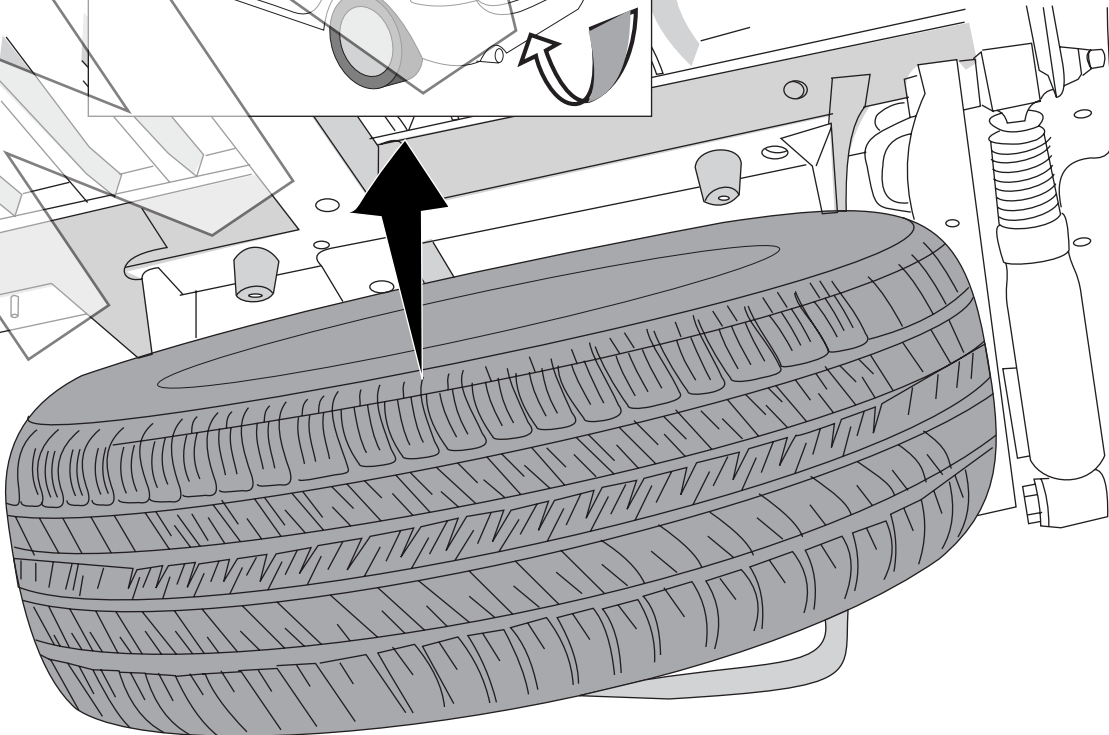

15

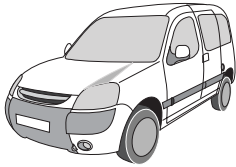

CITROËN BERLINGO



PEUGEOT PARTNER

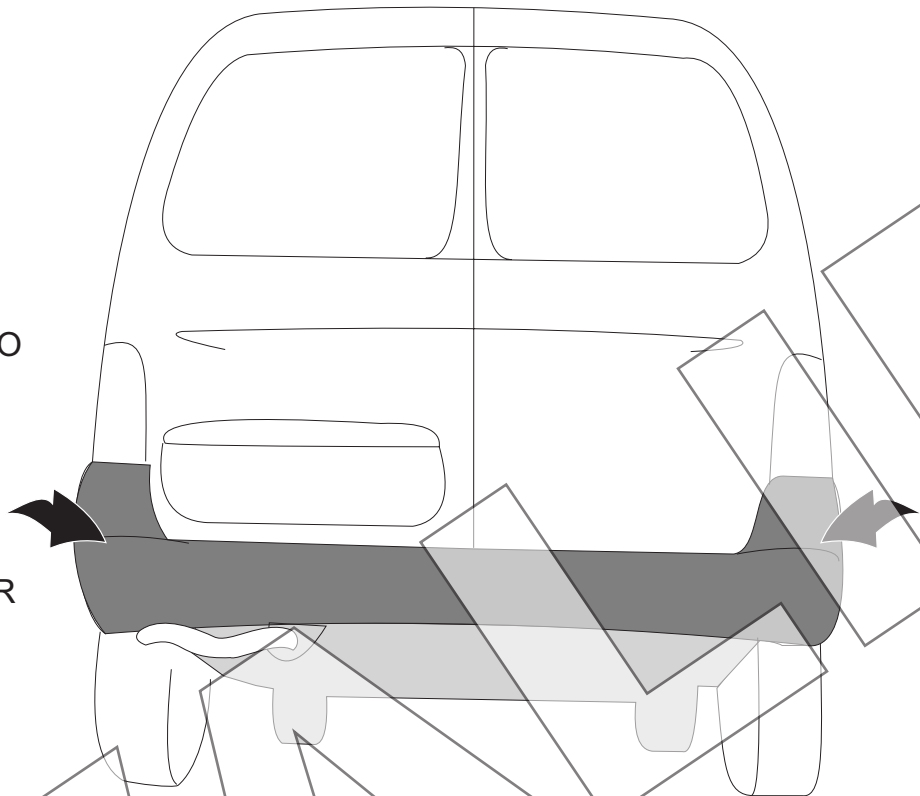

16

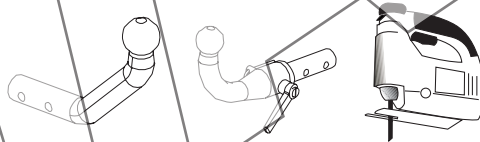

CITROËN BERLINGO



PEUGEOT PARTNER

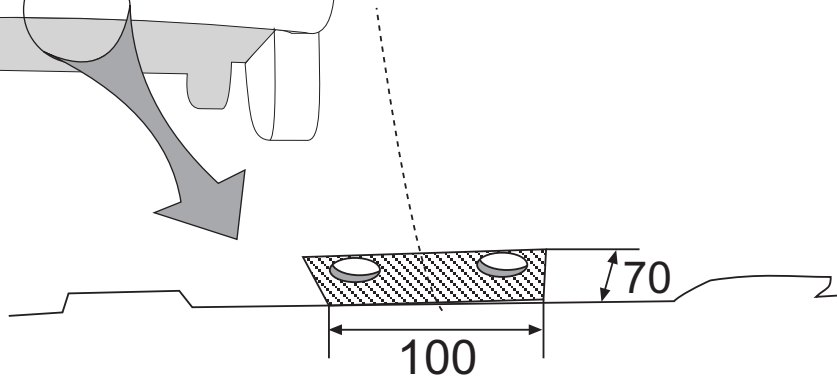
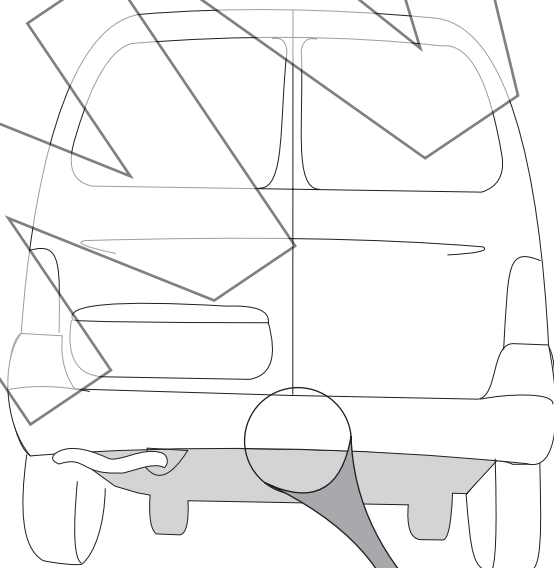



17

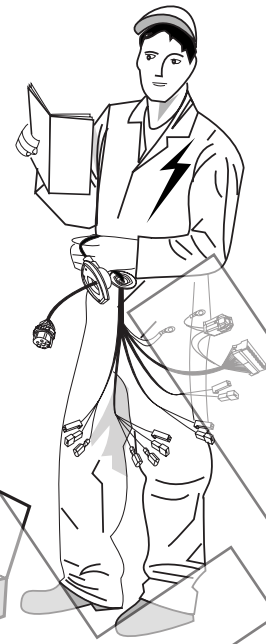
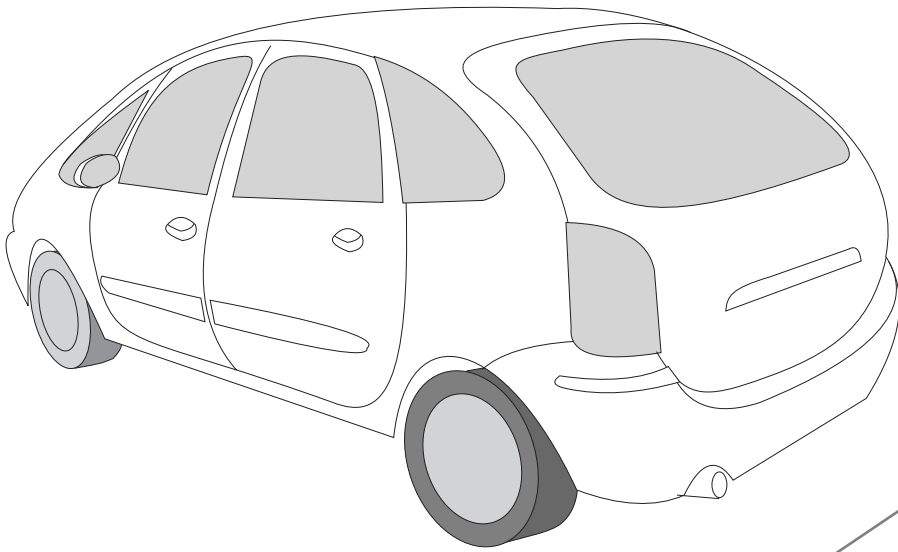

CITROËN BERLINGO  
PEUGEOT PARTNER  
CITROËN PICASSO

18

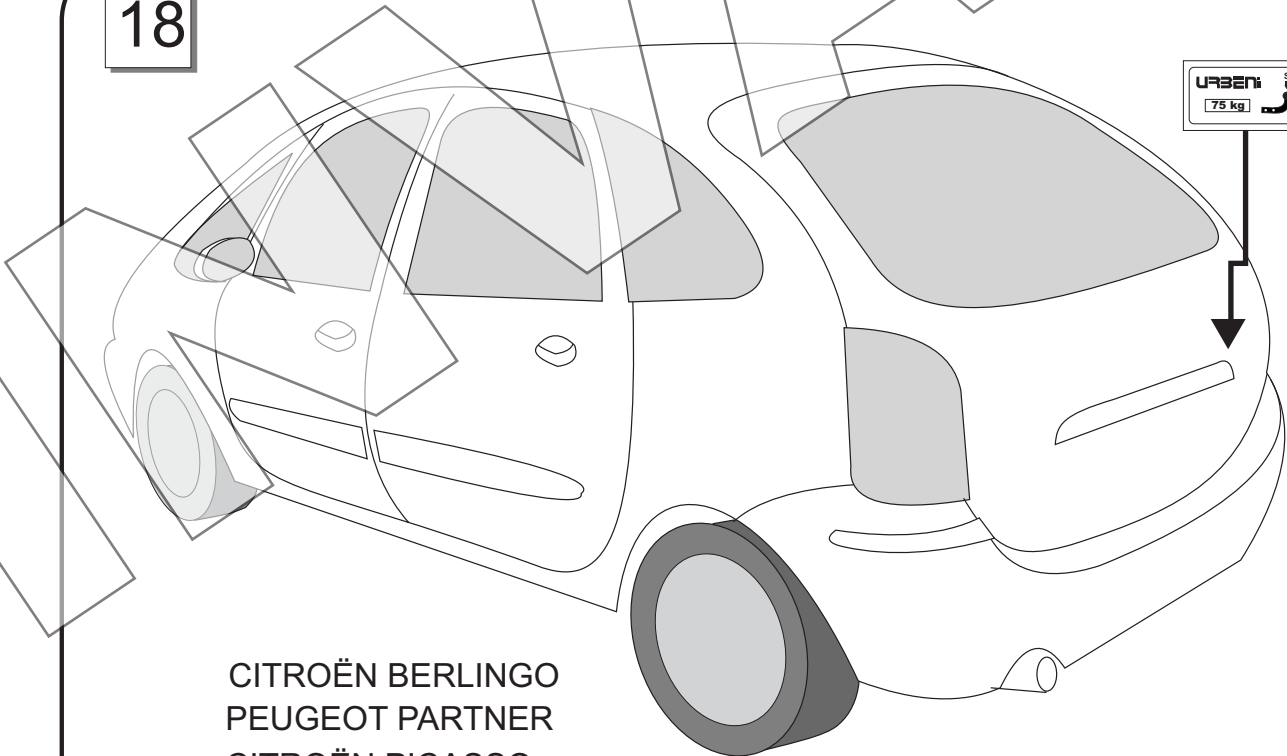

CITROËN BERLINGO  
PEUGEOT PARTNER  
CITROËN PICASSO

19

E I

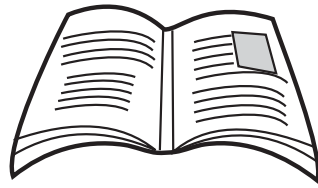

NL GR IRL DK  
GB F D CZ

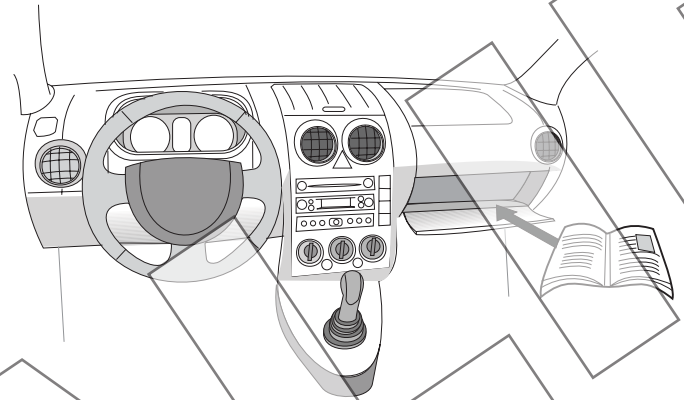
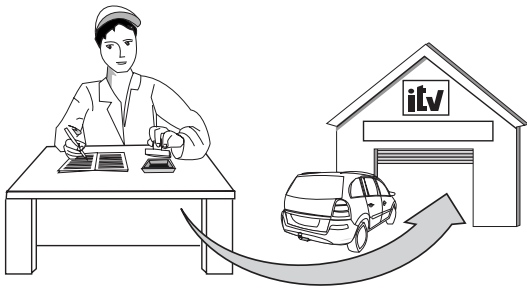

MANOVA



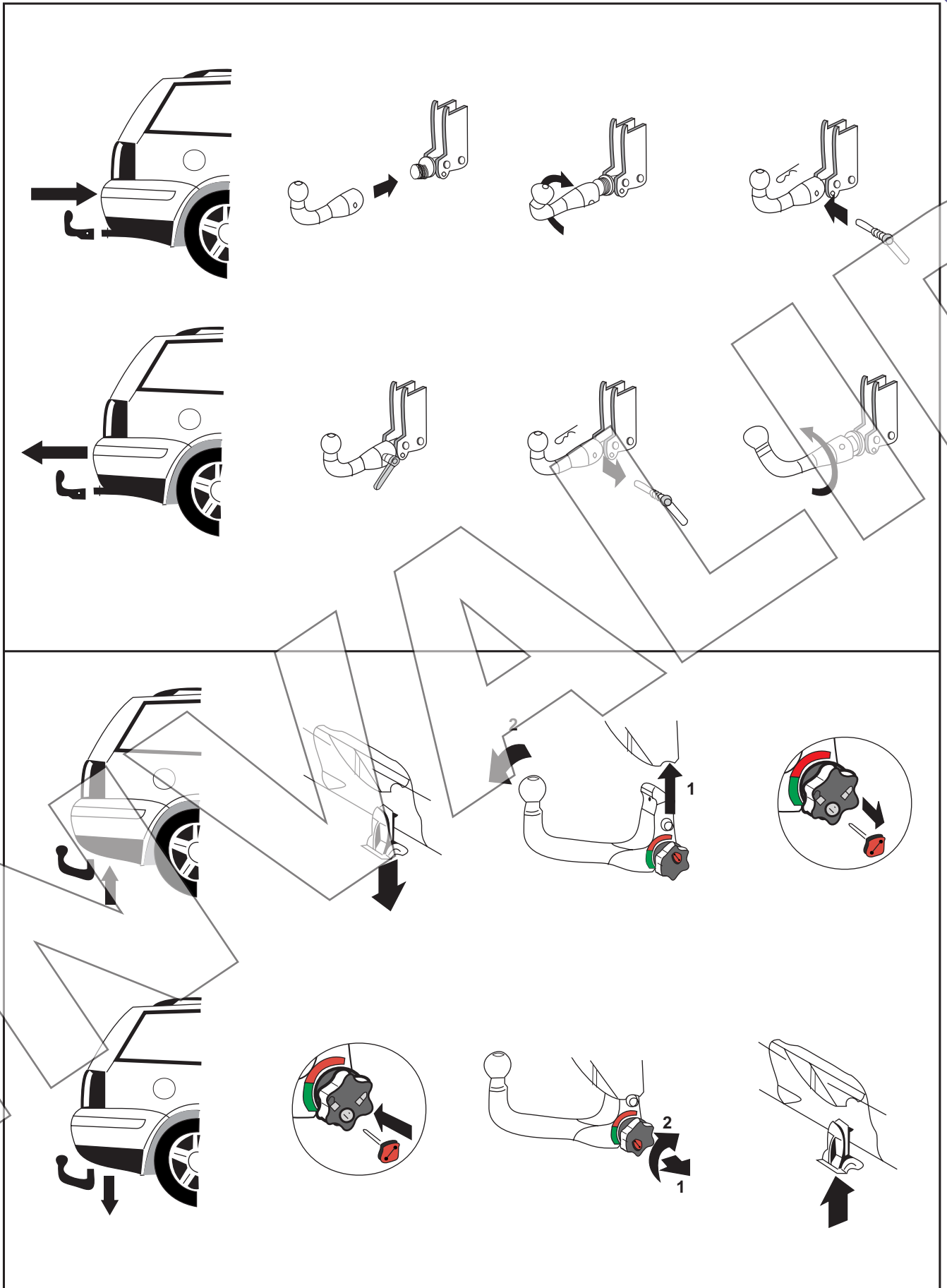

GRAND-DUCHE DE LUXEMBOURG

# MINISTÈRE DES TRANSPORTS

Luxemburg, le 08 mars 2000  
 19-21, Boulevard Royal  
 L-2910 LUXEMBOURG  
 Tél- 478-1 Télécopieur 241817 - Télex 1465 CIVAIR LU

REFERENCE : No e13\*94/20\*94/20\*0752\*00

ANNEXES : Documentation technique

## FICHE DE RECEPTION CEE EC TYPE-APPROVAL CERTIFICATE



**Communication concernant**  
 Communication concerning

- la réception  
the type approval
- l'extension de la réception  
the extension of type approval
- le refus de la réception  
the refusal of type approval
- le retrait de la réception  
the withdrawal of type approval

**d'un type d'élément de construction visé par la directive 94/20/CE<sup>(1)</sup>**  
 of a type of a component with regard to Directive 94/20/EC<sup>(1)</sup>

**Numéro de réception<sup>(2)</sup> :**  
 Type-approval number<sup>(2)</sup> :

e13\*94/20\*94/20\*0752\*00

**Motif de l'extension :**  
 Reason of extension :

not applicable

### SECTION I SECTION I

**0.1. Marque (raison sociale du constructeur) :** URBENI  
 Make (trade name of manufacturer) :

**0.2. Type et descripton(s) commerciale(s) générale(s) :** C 016  
 Type and general commercial description(s) :

**0.3. Moyens d'identification du type, tels que marqués sur l'élément de construction :** see point 0.7.  
 Means of identification of type if marked on the component<sup>(3)</sup> :

**URBENi, S.L.**

Pol. Centrovía, A-2, Km 303, c/Buenos Aires, nº10  
 50196 LA MUELA-ZARAGOZA (ESPAÑA)  
 Tel.: +34 976 14 44 01 / +34 902 41 78 50  
 Fax.: +34 976 14 44 02

**DA COMPILARE PER IL COLLAUDO****DICHIARAZIONE DI CORETTO MONTAGGIO**

La sottoscritta Ditta dichiara di aver montato in maniera corretta ed in conformità alle prescrizioni sia del costruttore del veicolo che del costruttore del dispositivo stesso il seguente dispositivo di attacco meccanico:

Tipo: .....

Il dispositivo di attacco meccanico sopra descritto è stato installato su autoveicolo tipo:

.....

targa:

.....

Si dichiara inoltre di aver informato l'utente del veicolo sull'USO e MANUTENZIONE del dispositivo stesso.

**TIMBRO E FIRMA**

**Dispositivo di traino**  
**codice:**

**Per autoveicoli:**

**Tipo:**

**Clase e tipo di attacco:**

**Omologazione:**

**Valor D:**

**Massa Massima**

**Rimorchiabile:**

**Carico Verticale Massimo:**

**Larghezza max.**

**Rimorquiabile**

per Caravan e T.A.T.S.: ..... Vedere CARTA di  
**CIRCOLAZIONE VEICOLO**  
 (motrice) + 70 cm =.....  
 arrotondare ai 5 cm superiore

(vedi D.M. 28/05/85)



## Certificado del taller

D. ...., expresamente autorizado por la empresa  
 ...., domiciliada en ....., provincia de .....,  
 calle ....., n.º ..... teléfono .....,  
 dedicada a la actividad de ....., con n.º de registro industrial ..... y n.º de  
 registro especial (1) .....

### CERTIFICA

Que la mencionada empresa ha realizado la/s reforma/s, y asume la responsabilidad  
 de la ejecución, sobre el vehículo marca ....., tipo  
 ....., variante ..... denominación comercial  
 ....., matrícula ..... y n.º de bastidor  
 ....., de acuerdo con:

La normativa vigente en materia de reformas de vehículos.

Las normas del fabricante del vehículo aplicables a la/s reforma/s llevadas a cabo en  
 dicho vehículo.

El proyecto técnico de la/s reforma/s, adjunto al expediente.

### OBSERVACIONES:

INSTALACIÓN DE DISPOSITIVO PARA REMOLCAR,

MARCA: .....

Nº HOMOLOGACIÓN: e.....

VALOR D: .....kN

VALOR S: .....Kg

M.M.R.: .....Kg

Se garantiza que los equipos o sistemas modificados cumplen lo previsto en el artículo 6 del Reglamento  
 General de vehículos y, en su caso, en el artículo 5 del Real Decreto 1457/1986, de 10 de enero, por el que se  
 regula la actividad industrial en talleres de vehículos automóviles, de equipos y sus componentes, modificados  
 por 455/2010, de 16 de abril, por el que se modifica el Real Decreto 1457/1986, de 10 de enero, por el que se  
 regulan la actividad industrial y la prestación de servicios en los talleres de reparación de vehículos  
 automóviles, de sus equipos y componentes.

..... a ..... de ..... de 20.....

Firma y sello

Fdo.: .....

(1) En el caso de que la reforma sea efectuada por un fabricante se indicará N/A.



**URBENI, S.L.**

Pol. Centrovía Ctra. N-II km 303  
LA MUELA (ZARAGOZA)  
P.P.

