

Be inspired

Issued by  
Information and Communication mobile  
Haidenauplatz 1  
D-81667 Munich

© Siemens AG 2001  
All rights reserved. Subject to availability.  
Rights of modification reserved.

Siemens Aktiengesellschaft  
<http://www.my-siemens.com>

Ref.No.: A31008-H4600-A1-1-7619



ME  
45

User Guide



Thank you for buying a Siemens mobile phone. We wish you a lot of enjoyment and pleasure with it.

If you read through the user guide carefully, you will get to know all the functions of the phone. In particular, please observe the safety (p. 3) and PIN/Security precautions (pages 9-11).

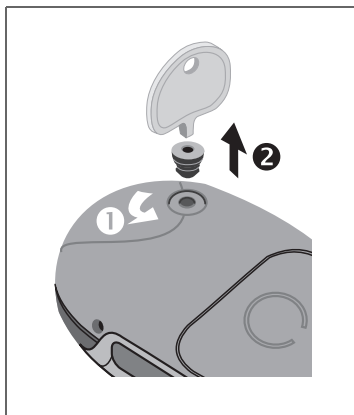

# Contents

<b>Safety precautions</b> .....	3	Location .....	23
<b>Overview of the phone</b> .....	4	Record no. ....	23
<b>General instructions</b> .....	6	Store control code .....	24
The User Guide.....	6	<b>Voice control</b> .....	25
Menu control .....	6	<b>Message (SMS)</b> .....	27
<b>Getting Started</b> .....	7	Read Messages .....	27
Insert SIM card/battery .....	7	Inbox/Outbox .....	28
Charge battery .....	8	Archive .....	28
<b>Switch on, off / PIN entry</b> .....	9	Use SMS sample .....	29
<b>Security</b> .....	11	Compose a message .....	29
<b>Making a phone call</b> .....	12	Picture & Sound (EMS) .....	30
Dialling with number keys .....	12	Text entry with "T9" .....	31
End call .....	12	Setup .....	33
Accept call .....	12	<b>Bitmap viewer</b> .....	34
Reject call .....	12	<b>WAP</b> .....	35
When a number is busy.....	13	Internet access .....	35
Redial previous numbers .....	13	Browser Menu .....	36
During a call .....	14	Setup .....	37
Swap/Conference .....	15	Profiles .....	37
Handsfree .....	16	Operating instructions .....	39
Send DTMF tones .....	16	<b>Voice message/Mailbox</b> .....	40
Babysitter .....	17	<b>Cell broadcast</b> .....	41
<b>Addressbook</b> .....	18	SIM Services (optional) .....	42
New entry .....	18	<b>Records</b> .....	43
Read/change an entry .....	19	Missed calls .....	43
Making a call .....	20	Calls received.....	43
Search for an entry .....	20	Calls dialled .....	43
Addressbook-Menu .....	20	<b>Time/charge</b> .....	44
Store control code .....	21	Display .....	44
<b>Phonebook</b> .....	22	Charge settings.....	44
New entry .....	22	<b>Divert</b> .....	45

See also Index  
at the end of this User Guide

<b>Dictaphone</b> .....	<b>47</b>	Filter .....	65
<b>Organiser</b> .....	<b>49</b>	Information tones.....	65
Calendar.....	49	Key tones.....	65
Appointments .....	50	1 minute beep.....	66
Tasks .....	51	Melodies .....	66
Alarm clock .....	52	Melody manager .....	66
Missed alarms .....	52	Compose melody.....	67
Notes .....	53	<b>Setup</b> .....	<b>68</b>
<b>Businesscard</b> .....	<b>54</b>	Device .....	68
<b>Calculator</b> .....	<b>55</b>	Security .....	71
<b>Currency conv.</b> .....	<b>56</b>	Network .....	72
<b>Time zones</b> .....	<b>57</b>	User group.....	74
Time/date.....	57	During calls .....	75
Format date .....	57	Connectivity .....	76
Auto phone off.....	57	Time/date.....	77
<b>Stopwatch/Countdown</b> .....	<b>58</b>	Accessories .....	78
<b>Games</b> .....	<b>59</b>	<b>Explorer</b> .....	<b>79</b>
<b>Profiles</b> .....	<b>60</b>	<b>Siemens Quick Sync</b> .....	<b>80</b>
Setup .....	60	<b>Fax/Data mode using a PC</b> .....	<b>81</b>
Car kit .....	61	<b>Send via .../Print via...</b> .....	<b>82</b>
Headset .....	61	<b>Display symbols (selection )</b> .....	<b>83</b>
Without Alarm .....	61	<b>Siemens Service</b> .....	<b>84</b>
<b>Favourites</b> .....	<b>62</b>	<b>Troubleshooting</b> .....	<b>85</b>
<b>Fast access key</b> .....	<b>63</b>	<b>Specifications/maintenance</b> .....	<b>88</b>
Left soft key .....	63	<b>Accessories</b> .....	<b>89</b>
Speed dialling numbers .....	64	Basics .....	89
Quick menu selection.....	64	Car Solutions .....	89
<b>Audio</b> .....	<b>65</b>	Data/Applications .....	90
Ringer setting .....	65	Innovations.....	90
Volume .....	65	<b>Index</b> .....	<b>91</b>
Silent alert.....	65		

See also Index  
at the end of this User Guide

All radio transmitters are subject to restrictions such as:



Switch off in hospitals or in the vicinity of medical devices, e.g. pacemakers or hearing aids. Mobile phones can interfere with the function of these devices.



Always use the handsfree kit for calls while driving (p. 89)!



Mobile phones must be switched off at all times in an aircraft. Prevent accidental activation (p. 61).



Switch off near petrol stations, fuel depots, chemical plants or blasting operations. Mobile phones can interfere with the operation of technical installations.



Do not examine the active infrared interface [Class 1 LED product (classified according to IEC 60825-1)] using optic magnification devices.



The ring tone is reproduced through the earpiece. To avoid damage to hearing, first accept the call, then hold the phone to the ear.



SIM card may be removed. Caution: small parts could be swallowed by children.



The mains voltage specified on the power supply unit must not be exceeded.



We recommend you use only original Siemens batteries (100% mercury-free) and charging devices. Otherwise considerable health risks and damage to the product cannot be excluded.



Neither the phone nor the battery (100% mercury-free) may be opened under any circumstances. Changes to this device are strictly prohibited, as they will invalidate the type approval criteria required for operation of the unit.

## Please note:



Dispose of used batteries and phones according to the legal regulations.



Mobile phones can interfere with the operation of nearby TVs, radios, PCs.





We recommend you use only original Siemens accessories to avoid possible damage and to comply with the existing regulations.

Improper use invalidates the warranty!



## Soft keys

The current functions of these keys are displayed in the grey fields as text or icons. These keys display the "quick selection" in standby mode (factory default: ) or e.g.  (SIM service) and Menu.

## Call key

Select displayed phone number or name, accept calls. Display last calls in standby mode.

## Ringer

To switch on and off:

 Hold **down**.



## Control key

• In standby mode:

 **Addressbook or Phonebook.**

 Voice control.

 Menu.

 GPRS Info-Menu.

• In lists and menus:

 Scroll.

 Select a function.

 Menu level back.

• SMS and Calendar:

 Move cursor.

 Scroll.

## On/Off/End key

**Press briefly:**

End call/application or return to standby mode.  
In menus: menu level back.

**Hold down:**

Switch on/off phone  
(in standby mode)

## Key lock

To switch on and off:

 Hold **down**.

 **OK** Confirm (switching off only).

## The User Guide

The following symbols are used:



Enter numbers or letters.



On/Off/End key.  
Hold **down** key: Go back to standby mode. In standby mode, switch off device.



Call key.



Press menu navigation key on the side indicated.



Displays a soft key function.



Function depends on the service provider, special registration may be necessary.

Steps for menu access in the user guide, e.g.:

**Menu** → Audio → Volume

The procedure above corresponds to:



Press soft key.



Scroll to **Audio**.



Select **Audio**.



Scroll to **Volume**.



Select **Volume**.

## Menu control

The menus provide access to functions, network services and individual settings.

### Main menu

To reach the main menu from standby mode at any time, press:

**Menu** right soft key

**or**



right menu navigation key.

### Menu control



Use the menu navigation key to scroll through the menus.



Select a submenu or a function.



Go back one menu level (or press  **briefly**).

### Option menu

In other situations (e.g. when the Addressbook/Phonebook is open, a corresponding option menu appears:

**Options** Press.



## Insert SIM card/battery

The service provider supplies you with a SIM card on which all the important data for your line is stored. If the SIM card has been delivered in credit card size, snap the smaller segment out and remove any rough edges.

- Use the enclosed disc to unscrew the cover **1**. Then remove the cover **2**.

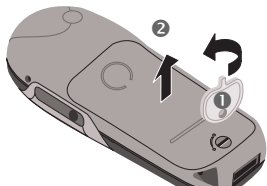

- Lift battery at the cutout on the side of the phone **3**, then tilt upwards and remove.



- Insert SIM card in the opening and push gently until it engages **4** (make sure the angled corner is in the correct position **5**, contacts pointing downwards).

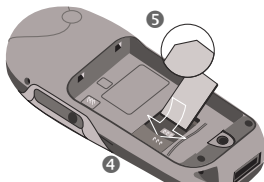

- Insert battery into the phoneside ways **6**, then press downwards **7**, until it engages.

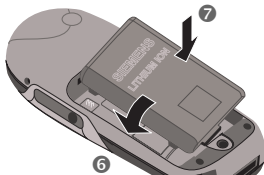

- Insert cover as shown **8**. Then press downwards, until it engages **9**.

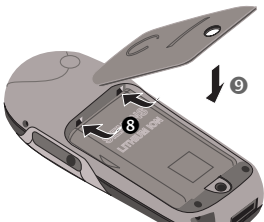

- Screw the cover back on with a quarter turn **1**.

Only 1.8/3-Volt SIM cards are supported. Older SIM cards (5-Volt technology) cannot be used. Please contact your service provider if you have an older card.

## Functions without SIM card

The phone is switched on **without** the SIM card:

**Menu** Press soft key.

All the functions that can be used without the SIM card are displayed. You will find a description of the functions in this user guide.

**SOS** Emergency number, SOS (page 9).

## Charge battery

The battery is not fully charged when delivered, so:

- Plug in charger cable at the bottom of the phone and plug in the power supply unit to the mains power socket (charge for at least two hours).
- Push the sides of the charger cable plug together and pull to remove it.

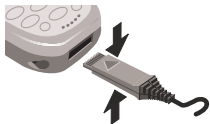

## Charging

The following is shown at the top of the display:

 When charging is in progress.

 End of charging.

An empty battery is fully charged after about 2 hours. Charging is only possible in an ambient temperature of 5°C to 40°C (the charge icon flashes as a warning when the temperature is 5°C above/below).

The voltage specified on the power supply unit must not be exceeded.

## Standby time

A fully charged battery provides 60 to 300 hours of standby time or 100 to 360 minutes of talk time. The standby times/talk times are average values and depend on the operating conditions (see table below).

Charge level display:

Fully    Empty charged

A beep sounds when the battery is nearly empty.

Operation carried out	Time (min)	Decrease of standby time
Calling	1	30 to 60 minutes
Display back light *	1	30 minutes
Network search	1	5 to 10 minutes

\* key input, games, organiser etc.

## Switch on, off



Hold **down** On/Off/End key to switch on or off.

## Enter PIN

The SIM card can be protected with a 4-8 digit PIN.



Enter your PIN code using the number keys (shown as a series of asterisks; if you make a mistake, press **Clear**).

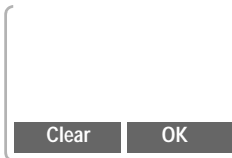

**OK** Confirm input with the right soft key.

Logging on to the network will take a few seconds.

When the name of the service provider appears on the display, the phone **is in standby mode** and **ready for use**.

**Network connection**

Strength of incoming signal.



A weak signal reduces the call quality and may lead to loss of the connection. Change your location.

If you are outside your "home network" your phone automatically selects a different GSM network (page 73).

**SIM Services**

Symbol for special applications on the SIM card (page 42), e.g. banking.

The phone and SIM card are protected against misuse by several security codes and should be treated with the same care as a cheque guarantee card.

For further details see also page 71.

**Keep these confidential numbers in a safe place where you can access them again if required.**

<b>PIN</b>	Protects your SIM card (personal identification number).
<b>PIN 2</b>	This is needed to set the charge detail display and to access additional functions on special SIM cards.
<b>PUK</b>	Key code. Used to unlock SIM cards after the wrong PIN has been entered.
<b>Phone-code</b>	Protects your phone. Must be entered at the first security setting (4 - 8 digits).

**Menu** → **Setup** →  
**Security** → then  
 select a function:

## Pin change

### PIN control

The PIN is usually requested each time the phone is switched on. You can deactivate this feature but you risk unauthorised use of the phone.

Some service providers do not permit this function.

### PIN

You can change the PIN to any 4-8 digit number (i.e. a number you may find easier to remember).



Enter **old** PIN.



Press.



Enter **new** PIN.



Repeat **new** PIN.

### PIN 2

You can change the PIN 2 to any 4-8 digit number (displayed only if PIN 2 is available).

Proceed as with **PIN**.

### Phonecode

You define and enter the phone code when you call up a phone code protected function for the first time. It is then valid for all functions.

You can change it to any 4-8 digit number.

## Dialling with number keys

The phone must be switched on (standby mode).



Enter the number (always with prefix, if necessary with the international dialling code).

**Clear** A **short** press clears the last digit, a **long** press clears the entire number.



Store phone number in the Addressbook (page 18)/ Phonebook (page 22).



Press the call key. The phone number displayed is dialled.

### International dialling codes

Many international dialling codes are stored in your phone:



Hold **down** until a "+" symbol appears. This replaces the first two digits of the international dialling code.

**+List** Press.

Select the required country. The international dialling code is displayed. Now add the national number (in many countries without the first digit if it is a zero) and press the Call key.

## End call



Press the End key **briefly**. The call is ended.

Press this key even if the person on the other end of the line has hung up first.

## Accept call



The phone must be switched on (standby mode).



**Reply** Press **or** press.



Calls can also be accepted by pressing any key (page 69).

## Reject call



**Reject** Press **or** press **briefly**.



**Divert** Diverts the caller e.g. to the mailbox if **Busy** is set (page 45) and "call waiting" (page 14) has been activated.

## When a number is busy

If the number called is busy or it cannot be reached because of network problems, the following options are available (depending on the service provider):

Either

### Auto redial previous numbers

**Auto dial** Press. The number is automatically dialled for up to 15 minutes at increasing intervals. During this period, no other number can be dialled. To end:

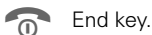

End key.

or

### Call back



**Call back** Press. Your phone rings when the busy number is available. The number is dialled with the Call key.

### Reminder

**Prompt** Press. A beep reminds you to redial the phone number after 15 minutes.

Any other call ends the function.

## Redial previous numbers

To redial the phone number **last** called:

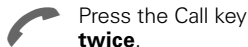

Press the Call key **twice**.

To redial other numbers that were dialled previously:



Press the Call key once.



Pick out the required phone number from the list, then press ...



... to dial.

**Options** Call lists (page 43).



Store phone number in the Addressbook (page 18)/ Phonebook (page 22).

The numbers of calls that have been received, dialled or missed are stored for call back purposes (page 43).

An incoming call will interrupt any other use of the phone.

Functions during the call (page 14).

Switch off ringer for the current call (but not if "Any key answer", page 69, is active) :



**Hold down**.

The call is displayed. The caller hears the dialling tone.

## During a call

### Call waiting



You may need to register for this service with your service provider and set your phone accordingly (page 75).

During a call, you may be advised that there is another call waiting. You will hear a special tone during the call. You have the following options:

### Swap

**Swap** Accept the waiting call and place the current call on hold.

To swap between the two calls, press **Swap** each time.

### Reject

**Reject** Reject the waiting call. The caller will hear the busy tone

**or**

**Divert** if this is set, the caller will be diverted to the mailbox for example (page 45).

### End current call



End the current call.

**Reply** Accept the new call.

### Set volume



You can adjust the handset volume with the keys **on the left-hand side of the phone**.

If a car kit is used, its volume setting does not affect the usual setting on the phone.

### Dictaphone

To play back a recording (the person on the other end of the line also hears it), press the key on the **right-hand side** of the phone **briefly**.

To record the call (page 47), hold **down** the key on the **right-hand side** of the phone.

The use of this feature may be subject to restrictions under criminal law or other legal provisions. Please inform the other party to the conversation in advance if you intend to record the conversation and please keep such recording confidential. You may only use this feature if the other party to the conversation agrees.

### Phone number memo

You can enter a number with the keypad during a call. The person on the other end of the line can hear the number being entered. It can be stored or contacted after the current call has ended.



## Swap/Conference

Some functions may not be supported by your service provider.

You can call another number during a call.

You can swap back and forth between both calls or link all callers together in a conference.

During a call, inform the other party of your intention, then:

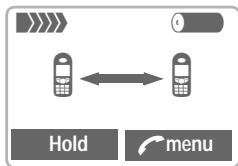

**Hold** Put the current call on hold.

You can now dial a new number. When the connection is established, you have the following options:

## Swap

**Swap** Swap back and forth between the two calls.

 End the current call.  
The following query is displayed:  
"Return to call on hold?"

**Yes** Return to the held call  
**or**

**No** The held call is ended.

## Conference

 **menu** Open call menu and select **Conference**.

A held call is added (conference call with up to 5 subscribers).

To end:

 All calls are ended simultaneously when the End key is pressed.

## Call transfer



 **menu** Open call menu and select **Call transfer**.

The original call is joined to the second one. For you, both calls are now ended. Note: Not yet supported by all service providers.

## Call menu

The following functions are only available during a call:

 **menu** Open menu.

<b>Handsfree</b>	See on the right.
<b>Microphone on</b>	Switch the microphone on or off. If switched off, the person on the other end of the line cannot hear you. DTMF signals, however, can be heard.  Alternatively:  <b>Hold down.</b> You will hear a DTMF key tone.
<b>Volume</b>	Adjust handset volume.
<b>Conference</b>	(page 15)
<b>Time/charge</b>	While the connection continues, the call duration and (if set, page 44) the call time/cost are displayed.
<b>Send DTMF tones</b>	See on the right.
<b>Call transfer</b>	(page 15)
<b>Main menu</b>	Direct access to the main menu.
<b>Call status</b>	List all held and active calls (e.g. participants in a conference).

## Handsfree

Activate, deactivate via the call menu see left.

You can put the phone aside during a call. You then hear the caller via the loudspeaker.

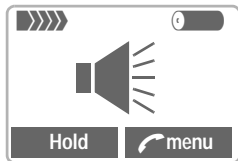

You can adjust the handset volume with the keys **on the left-hand side of the phone.**



To avoid damage to hearing, always deactivate the **Handsfree function** before holding the phone to your ear!

## Send DTMF tones

Activate via the call menu, see left.

You can enter control codes (digits) during a call so that an answering machine can be controlled remotely. These digits are directly transmitted as DTMF signals.

Control codes (DTMF tones) stored in the Addressbook (page 18)/ Phonebook (page 22), can also be entered.

## Babysitter

Calls are made to only **one** phone number that is dialled by holding **down** the right soft key.

### Switch on

**Menu** → Setup → Security → Babysitter

**Select** Press.



Enter phone code (see instructions below).

**OK**

Confirm input.

**Edit**

Press.



Select number from the Addressbook (page 18)/ Phonebook (page 22) or enter a new one (with name). The babysitter is now active.

### Switch off



Hold **down**.



Enter phone code.

**Edit**

Press.

**OK**

Confirm input.

#### Phonecode

When first prompted, you define and enter the Phonecode (4 - 8 digits) (e.g. for Babysitter)

**Please do not forget this code!**

It applies to other functions as well but it may be changed at any time (page 11).

You can store up to 500 entries, each with 3 phone numbers, and additional address information in the Addressbook. These entries are managed separately from those in the Phonebook. However you can exchange data between the Addressbook and the Phonebook.

## New entry

**Menu** → Office → Addressbook

or if the Addressbook has been selected (page 9) as standard:



Open the Addressbook (in standby mode).

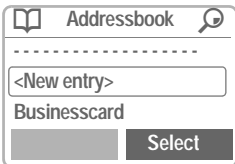

<New entry> Select.

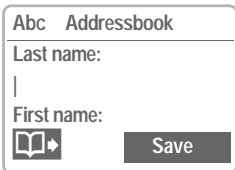

Enter the first or last name and a phone number (page 19).



Make further entries field by field.

Last name:	Fax:
First name:	Street:
Company:	Post code:
E-mail:	City:
Phone:	Country:
Tel./office:	URL: (Internet address)
Tel./mobile:	Group: (VIP, see below)

**Save** Store the entry.

### Group: (VIP)

You should only assign important entries to the VIP group.

You may display VIP entries at the top of the Addressbook (page 20).

You can set your phone so that the ringer sounds only for calls from numbers in the VIP group (page 65).

A call from a VIP entry can be announced by a special melody (page 66).



Copy data from a different Addressbook entry.

**Phone number**

Always enter phone number with prefix, if necessary with the international dialling code (page 12).

**Text entry**

Press number key repeatedly until the required letter is displayed. The relevant characters are shown in the display. The cursor advances after a short delay.

 **Press** once for A, twice for B etc. The first letter in each name is automatically written in UPPERCASE.

**Ä, ä/1-9** Umlauts and numbers are displayed after the relevant letter.

**Clear** Press briefly to delete the letter before the cursor, hold down to erase the whole name.

 Move the cursor.

 Switch between UPPERCASE, lowercase and digits.

 Switch T9 on and off.

 Write: . , ? ! 0 + - :

 Space.

**Special characters**

&, @, ... Special characters (page 31).

**Read/change an entry**

You can access all entries via the address list.



Open the Addressbook (in standby mode).



Select required entry.

**View**

Press to display the entry.

 **Addressbook**

---

Last name:  
Einstein

First name:

**Edit**

**Edit**

The entry is opened for changes.



Make the required changes.

**OK**

Save the setting.

**Right soft key**

When you jump from line to line while you are reading, the right soft key changes depending on the type of data:

Phone, fax number:

**VoiceDial** (page 25)

URL:

**Link** (page 35)

Activate the relevant application with the soft key.

## Making a call



Open the Addressbook (in standby mode).



Select a name by entering the first letter and/or scroll.

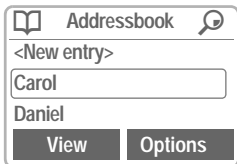

Press. The highlighted number is dialled.

If several numbers are stored in this entry, they are displayed in a list.



Select the required phone number.



Press.

## Search for an entry

You can search efficiently through large Addressbooks. When the Addressbook is open, simply type the first letter of the name required.

The first entry that begins with this letter is displayed.

The search letters appear in the upper right-hand corner of the display next to the magnifying glass icon.

## Addressbook-Menu

The following functions are available depending on the current situation:

**Options** Open menu.

View	(page 19)
Group sorting	Show the Addressbook as an alphabetical list or with the entries of the VIP displayed at the top (page 18).
Edit	Display the entry for changes.
New entry	(page 18)
Delete	Delete entry.
Delete all	Delete all entries after confirmation.
Copy to SIM	Highlighted entries are copied with name and the first phone number to the SIM card.
Phonebook	Switch to the Phonebook (page 22) and insert them as standard.
Send via ...	(see page 82)
Print via IrDA	(see page 82)
Voicedialling	Start the recording for voicedialling.
Capacity	Display the capacity used and available.

## Store control code

You can store phone numbers **and** control codes (DTMF signals) in the Addressbook as standard Addressbook entries, e.g. for operating an answering machine by remote control.



Dial number.



Hold down until a "+" appears on the display (pause for connection setup).



Enter DTMF signals (digits).



If necessary enter other pauses of 3 seconds to ensure correct processing at the destination.



Press to copy to the Addressbook and if required assign a name to it.



Press.

You can also store the DTMF signals (digits) like a phone number and send (page 16) them during a call.

### Extending numbers

Using an external PC program such as Outlook®, parts of a phone number can be replaced by "?" and then transferred to the Addressbook (for PABXs for example).

To call:



Open the Addressbook and select (part of) the phone number.



Press.



Replace "?" with digits.



Dial number.

### Synchronising with Outlook®

You can synchronise your Addressbook with your Outlook® database using Siemens Quick Sync (page 80).

The entries in the Phonebook (SIM card) are managed separately from those in the Addressbook. You can, however, exchange data between the Phonebook and the Addressbook.

## New entry

**Menu** → Office → Phonebook

or if the Phonebook is standard (page 9) ...



...open Phonebook (in standby mode) :

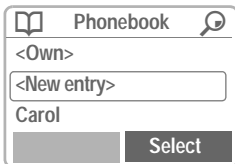

<New entry> Select.



Activate input fields.



Make the following entries:

Phone number (with prefix)

Name

Location (page 23)

Record no. (page 23)



Press to store.



The phone number can be dialled immediately

or



end input,  
e.g. for a new entry.

If entries are copied from the Phonebook to the Addressbook, further data (page 19) can be added to them subsequently.

## Phonebook-Menu



Select entry.



Open menu.

View	Display the selected entry.
Edit entry	Change first names and/or name, phone number and storage location.
New entry	Enter first and/or name, phone number and storage location.
Delete	Delete the selected entry.
Delete all	Delete all entries after confirmation.
Voicedialling	Use voice dialling to make an entry (page 25).
Copy into 	Copy selected entry to the Addressbook.
Reload	Copy all Phonebook entries to the Addressbook.
Address-book	Switch to the Addressbook (page 18) and set them as standard.
Send/print	(see page 82)
Capacity	Display the capacity used and available.



## Location

In the open Phonebook:



Select entry.



Open the menu and select **Edit** entry.



Go to the input field **Location**.

An entry can be moved from the Phonebook to other storage locations.

### SIM (standard)

Numbers that are stored in the Phonebook on the SIM card can also be used on another GSM Phone.

### Protected SIM



With a special SIM card, dialling can be limited to phone numbers that are "permanently" set on this SIM card. PIN 2 is required for editing (page 11).

### Mobile (phone memory)

Phonebook/Addressbook entries are stored here, if

- voice recognition is assigned to them,
- the memory of the SIM card is full.

## Record no.

A record number is automatically assigned to every new entry in the Phonebook. You can also dial with this record number.

### Making a call



Enter record number.



Press.



Press.

### Edit

In the open Phonebook:



Select entry.



Open the menu and select **Edit** entry.



Go to the input field "Record".



Enter the new number and confirm with **Save**.

You will be advised if the number already exists. Old numbers can be overwritten or the positions can be changed.

## Store control code

You can store phone numbers **and** control codes (DTMF signals) in the Phonebook as standard Phonebook entries, e.g. for operating an answering machine by remote control.



Dial number.



Press until "+" appears on the display (pause for connection setup).



Enter DTMF signals (digits).



If necessary enter other pauses of 3 seconds to ensure correct processing at the destination.



Press to copy to the Phonebook and if required to assign a name to it.



Press.

You can also store the DTMF signals (digits) like a phone number and send (page 16) them during a call.

### Service numbers

Numbers that have been provided by your service provider may be stored. With these numbers you can call local or nationwide information services or use services of the service provider.

### Protected phone numbers

Please note that the use of your Phonebook may be restricted (usual for some business applications), e.g. incomplete phone numbers may be indicated by a "?". These can be completed before dialling.

Up to 20 phone numbers or functions can be selected or started by simply saying a name. Voice dialling entries are stored in the phone (not on the SIM card!).

## Record

### Voice dialling for phone numbers

**Menu** → **Office** →  
**Voice control** →  
**Voice dialling**

A list with entries is displayed. In the list select...

**New record**, then



enter name and phone number

or



retrieve from the Phonebook.



Confirm.



Start the recording.

A short signal sounds. Now say the name and **repeat** it when prompted. A beep confirms the recording and all entries are displayed.

### Voice command for functions

**Menu** → **Office** →  
**Voice control** →  
**Voice command**

A list with 20 functions is displayed



Select a function.



Press.



Confirm selected function.



Start the recording.

A short signal sounds. Now say the command corresponding to the function and **repeat** it when prompted.

## Apply



**Hold** down. Start Voice control (in standby mode).

Now say the name or the function. The number is dialled or the function is carried out.

## Voice control-Menu

**Menu** → Office →  
 Voice control →  
 Voicedialling or  
 Voice command



Highlight required entry.

**Options** Open menu.

New record	Start a new recording.
New sample	Redo the (voice) recording of an entry.
Delete	Delete entry.
Edit	Change name and phone number (voice dialling only). Then redo recording if necessary.
Delete all	Delete all entries after confirmation.
Play	Play back the recording belonging to the entry.

You may transmit and receive messages on your phone (up to 160 characters in length).

Depending on your service provider, e-mails and faxes can also be transmitted via SMS (change settings if necessary, page 33) and e-mails can also be received as SMS messages.

## Read Messages



Display indicates a new message.

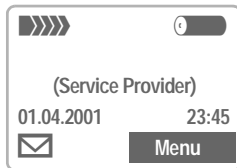

Press the key underneath the letter symbol to read the message.

Date/time  
Number/  
sender  
Message

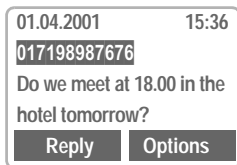

Scroll through the message (depending on length of the text)



Line by line using the menu navigation key.



Page by page using the side keys.

**Reply**

Reply menu see below.

**Options**

Inbox/outbox menu (page 28).



The archive function is displayed at the end of a message. This moves the message to the archive (page 28).

## Reply menu

Write message	Create (page 29) a new reply text.
Edit	Edit message received or assign a new text to it.
Answer is YES	Add YES to the message.
Answer is NO	Add NO to the message.
Predefined text	Add a standard text to the message, e.g. I'll be late Please call back

When the message has been edited in the editor, it can be stored or sent with **Options**.



The memory is full when the message symbol flashes. **No more** SMS messages can be received. Delete or save (page 28) messages.

Numbers highlighted in the message can be dialled (Dial key), stored (page 18) in the Addressbook/Phonebook or used as the address for a reply.

## Inbox/Outbox

**Menu** → Messages →  
Inbox/Outbox → SMS

The list of saved messages is shown.

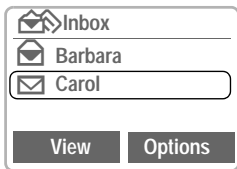

**Options** See on the right.

Symbol	Inbox	Outbox
	Read	Not sent
	Unread	Sent

## Archive

**Menu** → Messages →  
Inbox/Outbox →  
Inbox-Archive/  
Outbox-Archive

The list of messages recorded on the device is shown.

## Archive Menu

Different functions are available depending on the situation:

**Options** See on the right.

## Lists/Archive Menu

Depending on the situation, different functions are available

**Options** Open the list menu.

<b>View</b>	Read entry.
<b>Edit</b>	Open editor for changes.
<b>Copy to archive</b>	The archive function is displayed at the end of a message. This moves the message to the archive.
<b>Delete</b>	Delete the message selected.
<b>Delete all</b>	Delete all entries after confirmation.
<b>Send</b>	Dial number or select from Addressbook/Phonebook, then send.
<b>Save no. to</b> 	Copy the phone number selected to the Addressbook/Phonebook.
<b>Reply</b>	When an SMS arrives answer at once.
<b>Mark as unread</b>	Mark the message as unread.
<b>Print via IrDA</b>	(see page 82)
<b>Capacity</b>	Display number of saved messages and the capacity available.
<b>Status report</b> 	(Outbox list only) Request delivery confirmation for messages sent.

## Use SMS sample

The following standard messages are stored in the phone. You only need to add time and date.

**Menu** → Messages → Use SMS sample

Selection:

Delay, Appointment, Congratulations

The cursor appears at the first input point, e.g.:

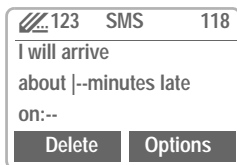

Complete the message.



Jump to the next input point.

**Options** Open the text menu.

**Send** Select.

Dial number or select from the Addressbook/Phonebook and transmit.

### Information on SMS

Transmission of an SMS is confirmed with **Message sent**.

The **Message sent** text only indicates that the message has been transmitted to the service centre. The latter now tries to deliver the message within a certain period.

If the phone was unable to send the message, a **retry** option is available. If this attempt also fails, contact your service provider.

## Compose a message

**Menu** → Messages → New SMS



Text input using "T9" allows you to quickly create long SMS messages using just a few key entries (page 31).

To delete letter for letter, press **Delete**.

### Either



Press.



Dial number or pick out from the Addressbook/Phonebook.

**OK**

Confirm.

**Send**

Select. The message is sent to the Service Centre for transmission.

**Save**

The text can be saved after transmission.

or

**Options**

Open the text menu.

Select **Send via ...** (page 82).

If **Message Type**, **Validity period** or **Service Centre** are requested see p. 33.

## Text Menu

**Options** Open the text menu.

Send	Dial the number of the address or select from the Addressbook/Phonebook, then send.
Save	Save the composed message in the outbox list.
T9 input (page 31)	Switch on/off Activate or deactivate intelligent text entry. T9 language Select the language in which the message is to be composed.
Insert new line	Enter a line break.
Delete text	Delete the whole text.
Insert picture	Insert (page 30) a picture into an SMS.
Send via ...	(see page 82)
Print via IrDA	(see page 82)
Insert from...	Open the Addressbook/Phonebook, highlight the required entry and copy it into the text.

## Picture & Sound (EMS)

Pictures and sounds can be inserted into a message. Playback only occurs if the destination phone supports this EMS function. In input mode a wildcard is shown instead of the picture/sound.



Compose the message as usual.

**Options** Open the text menu at the end of a word.

### Picture & Sound

Select. The first of 15 pictures from the picture list is shown.

### Pictures



Scroll in the list to the required picture.

### Select

The picture is "inserted" and shown as a wildcard.

### Sounds

#### Picture & Sound Select.

### Sounds

Select. The first of 10 sounds is played.



Scroll in the list to the required sound.

### Select

The sound is "inserted" and shown as a wildcard.



## Text entry with "T9"

"T9" deduces the correct word from the individual key entries by making comparisons with an extensive dictionary.

### Select T9 language

Select the language in which you want to compose your message.

**Options** Open the text menu then select **T9 input** and **T9 language**.

### Create a word using T9

Since the display changes as you proceed **it is best if you finish a word without looking at the display.**

You simply press the keys where the relevant letter are located **once** only. For "hotel" for example type

(4 ghi) (6 mno) (8 tuv) (3 def) (5 jkl)

T9 converts language specific special characters (such as ä, à) for you. Simply compose the message using the respective standard character, e.g. A instead of Ä.

If the word that T9 has chosen is not the one you want see "T9 word suggestions", page 32.

 Press **once** for uppercase/lowercase,  
Press **twice** for letters/digits.

### Activate, deactivate T9 (SMS)

## T9 word suggestions

If several options are found in the dictionary for a key sequence (a word), the most frequent one is displayed first. If the word you want has not been recognised, the next suggestion from T9 may be correct.

The word must be **highlighted**. Then

 press. The displayed word is replaced with a different word. If this word is also incorrect,

 press again. Repeat until the correct word is displayed.

If the word you want is not in the dictionary it may be written without T9 or added to the dictionary.

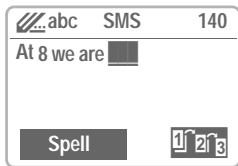

**Spell** Select.

The last suggestion is deleted and the word may now be entered without T9 support. Press **Save** to add it automatically to the dictionary.

## Correct a word

Words that have been created **using** T9:



Move word by word to the left/right until the required word is highlighted.



Scroll through the T9 word suggestions again.



Deletes the letter on the left of the cursor **and** displays a new possible word.

Within a "T9 word", individual letters may not be edited without cancelling T9 first. In most cases it is better to rewrite the complete word.

Words that have **not** been created using T9:



Move character by character to the left/right.



Deletes the letter to the left of the cursor.



Symbols are inserted at the cursor position.



Scroll line-by-line.

Replace existing languages:

<http://www.my-siemens.com/me45>

T9® Text Input is licensed under one or more of the following: U.S. Pat. Nos. 5,818,437, 5,953,541, 5,187,480, 5,945,928, and 6,011,554; Canadian Pat. No. 1,331,057; United Kingdom Pat. No. 2238414B; Hong Kong Standard Pat. No. HK0940329; Republic of Singapore Pat. No. 51383; Euro.Pat. No. 0 842 463 (96927260.8) DE/DK, FI, FR, IT, NL, PT, ES, SE, GB; and additional patents are pending worldwide.

## Setup

The transmission characteristics of an SMS are defined in a profile (maximum 5).

The presetting depends on the SIM card used.

**Menu** → Messages → Setup → SMS

The list of available profiles is displayed. You can select a profile from this list. To activate:

**Activate** Press.

## Setup menu

**Options** Open menu.

Activate	Use the profile selected.
Change settings	Change profile.
Rename	Rename the profile.

## Service Centre

Enter or change the phone numbers of the service centres as supplied by the service provider.

## Recipient

Enter the standard recipient for this transmission profile.

## Message type

Variable	The message type is requested for each message.
Standard text	Normal SMS message.
E-mail	Transmission via SMS.

Fax	Transmission via SMS.
New	You may need to obtain the required code number from your service provider.

## Validity period

Selecting the period in which the service centre tries to deliver the message:

Variable, 1 day, 1 hour, 12 hours, 1 week, Maximum\*, New

\*Maximum period that the service provider permits.

## Status report



You are given confirmation of the successful or unsuccessful delivery of a sent message. This service may be subject to a charge.

## Direct reply

The reply to your message is handled via your service centre when this function is activated (for information please contact your service provider).

## SMS via GPRS



**Menu** → Messages → Setup → SMS via GPRS

When this function is activated, SMS messages are automatically sent via GPRS.

Requirement: GPRS must have been activated see page 76.

A graphic can be sent to your phone via infrared or SMS or it can be downloaded via WAP.

## Receive graphic

A received graphic is indicated by a symbol above the left soft key. By pressing this key, the Bitmap viewer is started and the graphic is displayed.

## Store graphic

Select storage location of the graphic:

Screensaver (see on the left) or Logo

## Load graphic

**Menu** → Surf & fun → Bitmap viewer

**Bitmap viewer** Open.

**Options** The menu is opened.

**Load bitmap** Select.

## Bitmap viewer-Menu

**Options** Open menu.

Save as...	Store the current graphic on one of the storage locations or in the Explorer.
Load	Load graphic from the memory or from the Explorer.
Discard	The current graphic is discarded.
Delete	Delete the graphic.
Send via	(see page 82)
...	

Get the latest WAP information from the Internet that is specifically adapted to the display options of your phone. Internet access may require registration with the service provider.

## Internet access

**Menu** → Surf & fun → Internet

You can select the Internet access profile (see **Start with...** page 36 ). The start menu appears, e.g.:

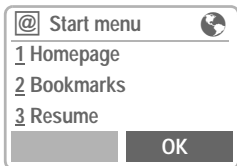

Select the required function





Confirm.

You can now surf the Internet ...



Hold **down** to end the connection.

 Offline  Online  no network  
The current display is in the upper right corner.



Scroll by using the side keys.

## Start menu

Homepage	The connection to the Internet provider's portal is established (may be set/preset by the service provider).
Bookmarks 	Display up to 10 URLs (Uniform Resource Locator) for fast access (not supported by all providers). Select <b>New entry</b> to enter a new URL. Use <b>Options</b> to complete, edit and delete entries.
Resume	Call up recently visited pages that are still in memory.
Profiles	Set up to 5 access profiles (page 37). Select <b>New entry</b> to enter a new profile

## Example: Homepage

The soft keys may be assigned functions that are controlled online from the homepage of your service provider such as "links" or "menus".

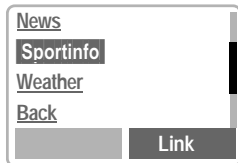

The contents of the option menus are also variable.

## Browser Menu

Menu access is only made when a WAP page is displayed (online or offline):



**Press to start the browser menu.**

<b>Homepage</b>	The first WAP Internet page that is displayed after connection is established (may have been set/preset by the service provider).
<b>Bookmarks</b>	Display up to 10 URLs for fast access (not supported by all providers). Use <b>New entry</b> to enter a new URL. Use <b>Options</b> to complete, edit and delete entries.
<b>Resume</b>	Call up recently visited pages that are still in memory.
<b>Go to URL</b>	Enter an URL for directly accessing an Internet address

## Setup

Preparation of the phone for Internet access depends on the service provider currently used:

- If the settings have already been made by the service provider you may begin immediately.
- If access profiles have already been assigned by the service provider, select a profile and activate it (page 37).
- The access profile must be set and activated manually (page 37).

If necessary, check with your service provider for details.

## Profiles

You can set or change up to 5 access profiles (may be barred by the service provider). The entries and functions may vary depending on your service provider. You can change a profile each time before you access the Internet (page 38).

### Profile settings

To create a new profile proceed as follows:

**Menu** → Surf & fun → Internet → Profiles



Select the profile to be changed.

**Edit**

The entry card is displayed.



Make your entries field by field.

You may get further information on the entries from your service provider.

<b>Profile name:</b>	Name the profile or rename a default name.
----------------------	--

GPRS and CSD data see page 76.

<b>Wap parameters</b>	<p><b>IP address:</b> Enter IP address.</p> <p><b>IP port:</b> Enter port number.</p> <p><b>Homepage:</b> Enter homepage (page 37) if not set by the service provider.</p> <p><b>Linger time:</b> Enter time in seconds after which a connection should be terminated if no input or data transfer takes place.</p>
-----------------------	---

**Save**

The settings are stored and the profile list is shown.

### Special characters (as in the SMS text editor)



Press 3 x for /



Press 3 x for @



Press for . (full stop)



Press repeatedly for :



Press repeatedly for ~

## Activate profile

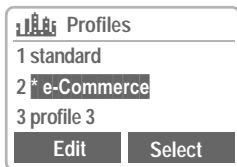

### Activate

Activate a profile to establish the Internet connection.

**Menu** → Surf & fun →  
Internet → Profiles



Select the required profile.

**Activate** Press to activate. The connection is established.

Your Internet browser is licensed by:



**OPENWAVE™**



Surf also with GPRS (page 76).



## Operating instructions

### Changing the homepage

The address of the homepage is set in the (access) profile. You can change it in standby mode (if permitted by the service provider!):

**Menu** → Surf & fun →  
Internet → Profiles

Select the profile, e.g.:

e-Commerce Select.

**Edit** The entry card is displayed.

Wap parameters/Homepage

Select.



Enter new address. Go to the end of the entry card.

**OK**

Press.

### Enter the Internet address (URL)

Menu access is made as soon as WAP pages are displayed (online or offline).



Open the browser menu.

Go to URL

Select and confirm.



Enter URL and confirm. The connection is established.

### Bookmarks



Depending on the provider you can store a list of your favourites with their Internet addresses (URL) in the phone (offline and online):

#### Store



Open the browser menu.

Bookmarks

Select and confirm.

**Menu**

Open menu.

New entry

Select and confirm.



Enter the favourite and its URL and confirm.

#### To use a favourite

Proceed as with "Store"; in the list select the stored bookmark instead of "Options" and confirm. The connection is established.

Most service providers offer you an external answering service. In this mailbox, a caller may leave a voice message for you

- if your phone is switched off or not ready to retrieve,
- if you do not want to answer,
- if you are making a phone call (and if **Call waiting** is not active, page 14).

If the voice mail service is not part of your service provider's user package, you will need to register and the settings must be made manually. The procedure described below may vary slightly depending on the service provider.

## Setup

Your service provider supplies you with two phone numbers:

### Mailbox number

You call this phone number to listen to the voice mails left for you. To set it up:

**Menu** → Messages →  
Voice message

Select a number from the Address-book/Phonebook or dial/change it and confirm with **Save**.

### Forwarding number

Calls are diverted to this phone number. To set it up:

**Menu** → Divert → e.g.  
Unanswered → Set

Dial the number of the mailbox.

**OK** Registration at the network. Confirmation is made after a few seconds.

For further information on call divert, page 45.

## Listen to

A new voice mail can be displayed as follows:

 Icon including beep.

or

 a text message announces a new voice mail

or

you receive a call with an automatic announcement.

Call your mailbox and play the message(s) back.



**Hold down** (if necessary dial the mailbox number of the service centre).

Outside your home network, a different mailbox number may need to be dialled and a password may need to be entered to access your mailbox.

## Cell broadcast



Some service providers offer information services (info channels) such as area codes, stock markets etc. The information available depends on the service provider. If reception is activated, you receive messages on the active topics in your "Topic list".

**Menu** → Messages →  
Cell broadcast

### Broadcast

You can activate and deactivate the CB service. If the CB service is activated, the operating time of the phone will be reduced.

### Read new CB

All unread CB messages are displayed.



Use the side keys to scroll.

The message covers the whole display.

### Topic list

You can add an unrestricted number of topics to this personal list from the topic index ("Topic retrieval", page 42). You can preset at least 10 entries with their channel number (ID) and, if necessary, with their name. Five topics can be active at one time.

### New topic

New topic Select.

- If no topic index is available (see "Topic retrieval", page 42), enter a topic with its channel number and confirm with **OK**.
- If the topic index has already been transmitted, select a topic and confirm with **OK**.

### Selection from a list

**Options** Open the list menu.

If a topic is selected in the list, you can have a look at it, activate it, deactivate it, edit it or delete it.

### Auto display

CB messages are displayed in standby mode, longer messages are automatically scrolled.

The automatic display can be set for all messages or only new messages or deactivated entirely.



then press **Read CB**

Switches to "full page view" automatically:

## Topic index



The list of the topics currently provided by your service provider is displayed for you to choose from.

If none are displayed, the channel numbers (ID) may be entered manually ("Topic list", page 41). Please contact your service provider for details.

## CB languages

You may define whether you want to receive Cell Broadcast messages only in a specific language or in all languages.

### Displays



Topic activated.



Topic deactivated.



New messages received on the topic.



Messages on the topic already read.

Highlighted phone numbers can be:



dialled.

**Options**

stored in the Addressbook/  
Phonebook.

Additional beep, page 65.

## SIM Services (optional)

Your service provider can offer special applications such as homebanking, stock market etc. via the SIM card.

If you are registered for one of these services, the service name will appear at the top of the Main Menu or directly above the left soft key.



Icon of SIM services.

If there is more than one application, these are displayed in the "SIM Services" menu.

**Menu** → SIM Services

With the SIM Services menu your phone is future-proof and will support additions to your service provider's user package. For further information, contact your service provider.

Your phone stores the phone numbers of calls for convenient redialling.

**Menu** → Records



Select required call list and select the number there.



Select number

**or**



view information on the phone number:  
date, time, number of calls.

The following call lists are available:

## Missed calls



The phone numbers of calls that you have received but not answered can be recorded for call-back purposes.

Requirement:

The networks used support the "Caller Identity" feature.

## Calls received



All accepted calls are listed.

Requirement:

The networks used support the "Caller Identity" feature.

## Calls dialled

Access to the last phone numbers you dialled.



Fast access in standby mode.

## Erase records

The contents of all call lists are deleted.

### Records-Menu

The call list menu can be called up if an entry is highlighted.

**Options** Open the list menu.

You can change an entry, delete all entries or transfer a phone number to the Addressbook/Phonebook.

You can display the charge details and duration of calls as you speak, as well as setting a unit limit for outgoing calls.

## Display

**Menu** → Records → Time/charge

After you have made the charge detail settings, you can display the call duration/charge details for the following call types or you can display the credit balance.

Last call  
All calls  
Remain. units

or

when total amount is deactivated:

Last call  
All outgoing  
All incoming calls  
Remain. units

Select a call type.

**Select** Display the data.

When displayed, you may do the following:

**Delete** Clear display.

**OK** End display.

## Charge settings

**Menu** → Records →  
Charge settings

### Currency

Enter the currency in which the charge details are to be shown.

### Charge/unit

(PIN 2 needed)



Enter the charges per unit/period.

### Account limit

(PIN 2 needed)



Special SIM cards allow you or the service provider to define a credit/period after which the phone is blocked for outgoing calls.

### Edit

Enter the number of units and confirm with

**OK**.

Then confirm the credit or reset the counter. The display of Prepaid cards may vary depending on service provider.

### All calls

Toggle between the displays.



### Incoming calls

If your network supports the charge detail display, the current units are displayed.



If you have set charge details per unit, the costs incurred are displayed.

Special registration may be necessary for this service.

### Auto display

Call duration/charges are automatically displayed for each call.

You can set the conditions for which calls are diverted to your mailbox or other numbers.

**Menu** → Divert

### You can set divert as follows:

The most common condition for forwarding is:

## Unanswered

**Menu** → Divert



Select  
Unanswered.

**Select** Press.

**Set** Select.



Enter the phone number to which a call will be diverted (if not done already)

**or**

select the phone number from the Addressbook/Phonebook or from the **Mailbox**, confirm with:

**OK** After a short pause, the setting is confirmed by the network.

### Unanswered

This setting covers the most important conditions (see also below):

Not reachable, No reply, Busy

## All calls

All calls are diverted.



Symbol in the top line of the display in standby mode.

## Specific divert

### If not reachable

Divert if the phone is switched off or out of range.

### No reply

A call is only diverted after a delay (depends on the network). The period can be set by the user to a maximum of 30 seconds in 5 second intervals.

### Busy

Divert if a call is in progress.

Exception: If **Call waiting** is activated (page 75), you will hear the call waiting tone (page 14) during a call.

## Receiving fax

Fax calls are diverted to a number with a fax connection.

## Receiving data

Data calls are diverted to a phone number with a PC connection.

## Status check

You can check the current divert status for all conditions.

After a short pause, the current situation is transmitted by the network and displayed.



Condition set.



Not set.



Displayed, if status is unknown (on a new SIM card for example).

## Clear all

All set diverts are cleared.

To check or delete a certain condition:

First select the condition.

**Select** Press.

Check status

or

Delete Select.

Note that the divert is stored in the network and not in the phone (when the SIM card is changed for example).

### Reactivate divert

The last divert has been stored.

Proceed as with **Set Divert**.

The stored phone number is displayed and is confirmed.

### Edit phone number

Proceed as with **Divert**. When the stored number is displayed:

**Delete** Delete the phone number.

Enter new number and confirm.



With voice recording you can

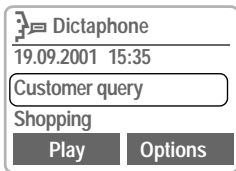

- use your phone as a Dictaphone when on the move.
- record a memo as a reminder or as a reminder for others.
- add a voice memo to an alarm in the Calendar (page 50).
- record a call - useful for remembering numbers or addresses.

Note: The use of this feature may be subject to restrictions under criminal law or other legal provisions. Please inform the other party to the conversation in advance if you intend to record the conversation and please keep such recording confidential. You may only use this feature if the other party to the conversation agrees.

## Using the side keys

We recommend using the keys on the side of the phone to control the voice functions..

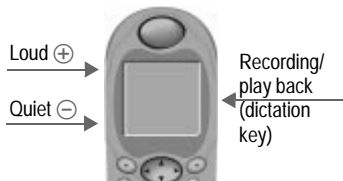

### New record

Press the dictation key for the duration of the recording. After a short beep, the recording starts.

For a **recording pause**, you can release the dictation key for a maximum of 10 seconds. If you press the key once more, recording is resumed, otherwise it will be stopped.

### Exit browser/Save

The record is stored if you release the dictation key for more than 10 seconds. It is stored with the current time and date as its name. A different name can be assigned to it afterwards.

### Play

Press the dictation key **briefly**.

## Using the soft keys

**Menu** → Office → Dictaphone

The list of the recordings is opened.

**Options** Open menu.

**New record** Select.

**Record** Start recording  
(**Pause** recording pause).

**Stop** End recording.

**Save** Store and assign a name.

### Play

**Play** Press.

## Using the menu navigation key

**Menu** → Office → Dictaphone

### New record

 Press **briefly on the left** to end.

 Press **briefly on the right** to pause/playback.

### Play

 Press **briefly on the right** to pause/playback.

 One recording forward or back.

 Hold **down**: Fast forward, rewind.

 End playback.

## Dictaphone-Menu

**Options** Open menu.

<b>Playing</b>	The recording is played.
<b>New record</b>	Start a new recording.
<b>Delete</b>	Delete the entry selected.
<b>Delete all</b>	Delete all entries after confirmation.
<b>Rename</b>	Replace the time stamp with a name.

## Calendar

**Menu** → Office →  
Organiser → Calendar

The Calendar offers a

- monthly view
- weekly view
- daily view.

The time and date must be set for the Calendar to work properly (page 77).

### Side keys

back →  Scroll between the weeks or months depending on the current view.

For-ward → 

### Monthly view

Th	Apr	2001	W	15
				1
2	3	4	5	6
9	10	11	12	13
16	17	18	19	20
23	24	25	26	27
				28
				29

**Week**      **Agenda**



Scroll through the weeks.



Scroll through the days.

**Week**

Display the weekly view.

**Agenda**

Display the daily view.

### Weekly view

Th	Apr	2001	W	15
M	T	W	T	F
9	10	11	12	13
				14
				15
8				
12				
16				

**Month**      **Agenda**



Scroll by the hour.



Scroll through the days.

**Agenda**

Daily view.

 Schedule. Time overlaps are highlighted.

Each day is divided into six blocks of four hours (morning + afternoon).

### Agenda

**Agenda**

Select.

Displays the appointments of the current day in chronological order in the agenda.

Tasks which are still open are listed at the top (page 51).

When an appointment with an alarm is reached, you will hear a beep.

#### Synchronise with Outlook®

With the Siemens Quick Sync software you can synchronise your organiser with your Outlook® Calendar (page 80).

## Appointments

**Menu** → Office →  
Organiser →  
Appointments

Displays all appointments/tasks as a list.

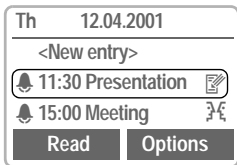

### New appointment

<New entry> Select.



Make the entries field by field:

**Category:** Select Appointments or Tasks.

**Type:**



Memo. A short text may be added.



Call. Enter phone number. Shown with alarm.



Meeting



Birthday



Voice memo

**Description:**

Display in the agenda.

**Alarm:**

Activate, Deactivate.

**Date:/End date:**

Start date, end date if necessary.

**Reoccurrence:**

Select periods for repeating the appointment.

**Start time:/End time:**

Start time, end time if necessary.

**Save** Store the appointment.

### Appointments menu

**Options** Open menu.

View	Show the selected entry.
Activate/Deactivate	Activate/deactivate the selected entry.
Edit	Open the entry for changes.
New entry	See on the left.
Delete	Delete the entry selected.
Delete all	Delete all entries after confirmation.
Send via ...	(see page 82)
Print via IrDA	(see page 82)
Week beg. Mo	Set when the week is to start, Monday or Sunday.
Capacity	Display the capacity used and available.

A total of 50 entries can be created. An alarm sounds even when the phone is switched off. To deactivate it press any key. Deactivate all alarms (page 60). Ringer setting (page 65), Clock (page 77).



Display when alarm is active.

**Pause**

Delays the alarm by 5 minutes.

## Tasks

**Menu** → Office → Organiser → Tasks

A task is displayed like an appointment in the agenda of the day selected. However unlike the appointment it does not need to have a time and date. When this is the case the task appears at the top of the list **every** day, until it is marked as done.

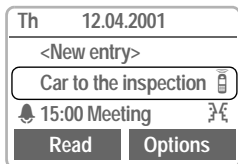

## New task

<New entry> Select.

**Category:** Select **Tasks** or **Appointments**.



Select the task type (see **Appointments**, page 50)



Describe the task briefly.



If necessary, enter date and time.



Store the task.



Display when a task is done.

## Task menu

**Options** Open menu.

<b>View</b>	Display the entry.
<b>Done</b>	Mark task as done.
<b>Edit</b>	Display the entry for changes.
<b>New entry</b>	Enter a new task.
<b>Delete</b>	Delete an entry from the appointments list.
<b>Delete all</b>	Delete all entries after confirmation.
<b>Send via ...</b>	(see page 82)
<b>Print via IrDA</b>	(see page 82)
<b>Week beg. Mo</b>	Set when the week is to start, Monday or Sunday.
<b>Capacity</b>	Display the capacity used and available.

## Alarm clock

**Menu** → Office → Organiser → Alarm clock

Use this function to set **a single** time for the alarm call. The alarm sounds even when the phone is switched off.

**On / off** Switching on and switching off the alarm.

**Edit** Displays the set time and days for the alarm call.

**Time** Set the time for the alarm call (hh:mm:ss).

**Days** Set the days for the alarm call with **Edit**.

## Missed alarms

**Menu** → Office → Organiser → Missed alarms

Appointments with alarms which you have missed are listed and can be displayed.

### Missed alarms Menu

**Options** Open menu.

You can send an alarm missed, print it, delete it or delete all alarms missed.

## Notes

**Menu** → Office → Organiser → Notes

T9 support (page 31) makes writing memos, e.g. shopping lists, easier for you. Protect confidential data with the phone code (page 11).

### New entry

<New entry> Select.



Enter the text.

**Options** Open menu.

**Save** Store the entry.

### Editor menu

**Options** Open menu.

Save	Store the entry.
T9 input (page 31)	Activate, deactivate: Activate intelligent text entry or deactivate it.  T9 language: Choose language in which the memo is to be composed.
Line feed	Enter a line break.
Delete text	Delete the memo.
Send	Transmit via SMS.

### Read entry

Notes

---

<New entry>

Shopping list

Office

**View**
**Options**



Select an entry.



Open.

### Notes menu

**Options** Open menu.

View	Display the entry.
Edit	Display the entry for changes.
New entry	Enter a new memo.
Delete	Delete an entry from the appointments list.
Delete all	Delete all entries after confirmation.
Confidential	Protect entry with phone code (page 11).
Send	Transmit via SMS.
Capacity	Display the capacity used and available.

You may create your own business card and transmit it as a message via SMS or you may transmit it to another GSM Phone (with IrDA capability) or a suitable PC/printer using infra-red technology.

**Menu** → **Office** → **Businesscard**

If a business card has not been created, you are asked for input.



Go from field to field and make your entries.



The phone numbers can also be copied from the Addressbook/Phonebook.

Last name:	Tel./mobile:
First name:	Fax:
Company:	City:
E-mail:	Post code:
Phone:	Street:
Tel./office:	Country:
URL:	

**Save** Press.

The content of the business card corresponds to international standards (vCard).

When you are sending a business card as an SMS, note that a maximum of 160 characters can be transmitted. If the card contains more than those 160 characters they will not be transmitted.

## Businesscard Menu

**Options** Open menu.

Send via ...	(see page 82)
Print via IrDA	(see page 82)
Edit	Display the business card for changes.



**Menu** → Office → Calculator



Enter number (up to 8 digits).



Select calculator function.



Repeat procedure with other numbers.



Result is displayed.

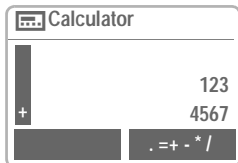

## Special functions

Repeatedly press the right soft key

**. = + - \* /** (indicated in the display).

- Set decimal point.
- = Result.
- + Addition.
- Subtraction.
- X Multiplication.
- / Division.
- ± Toggle between "+" and "-".
- % Convert to percentage.
- ↓ Save the number displayed.
- ↑ Retrieve the number saved.
- e Exponent (maximum of two digits).

## Special keys:

- Multiply.
- Add (hold **down**).

**Menu** → Office →  
Currency conv.

You may store up to three different currencies.

## Enter currency

To convert, enter at least two currencies. If currency has been entered, the input procedure is started immediately.

**OK** Press.



Enter the symbols for your own and for the foreign currency or select from the **€ List**:

EUR	ATS	BEF	DEM	ESP	FIM
FRF	IEP	ITL	LUF	NLG	PTE

**OK** Confirm.

For currencies that are linked to the Euro, **no** exchange rate has to be entered. Otherwise:



Enter exchange rate of a non-Euro currency.

**OK** Confirm.

Press the right soft key repeatedly (indicated in the display):



Set decimal point.

## Input Menu

**Options** Open menu.

OK	Confirm.
Decimal point	Enter decimal point.
Calculator MR	Retrieve a saved number.

## Convert

Any combination of calculations may be made between the entered currencies.



Select one combination from the list of possible combinations.

**Select**

Confirm.



Enter amount (up to 8 digits).



The result is displayed.

## Currency conv. Menu

**Options** Open menu.

Start	Carry out conversion.
New entry	Enter two new currencies.
Edit	Open input procedure with the two currencies selected.
Delete	Delete the two currencies.

**Menu** → Office → Clock → Time zones

## Time zones

Set the time zone for your area.



Select the required time zone from the list...

**Set**

... set it up.

**Options**

Open menu.

View	Display the time zone selected with name and date.
Set	Set the time zone.
Rename	Assign a new name to the time zone.
Auto timezone	The time zone is switched to local time automatically by the network.
Summer time:	Activate/deactivate daylight saving.

## Time/date

This function is identical to **time/date** on page 77.

## Format date

Set the date format:

DD.MM.YYYY or MM/DD/YYYY

## Auto display

The time display can be switched on and off.

## Auto phone off

The phone switches off each day at the set time.

**Activate:**

**Clock**

Press.



Enter time (24 h clock).

**OK**

Confirm.

**Deactivate:**

**Variable**

Press.

**OK**

Confirm.

Note: If the battery is removed for more than about 30 seconds, the clock must be reset.

## Stopwatch

**Menu** → Surf & fun → Stopwatch

Display the time down to one thousandth of a second. Two intermediate times can be clocked and stored.



**Reset** Reset to zero.



Start/stop.



Intermediate time.

Control using the side keys:

**Menu** → Surf & fun → Games

Select a game from the list and have fun!

## Game instructions

You will find special instructions for each game in the option menu.

**Options** Provides tips on how to play the game, shows the saved scores and allows you to set the difficulty level.

**Start** Start game.

## Key control

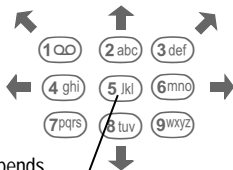

function depends  
on the game

**or** use the menu navigation key:

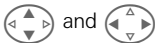

If a profile is used, several settings are made with **one** function.

- Five profiles are standard with default settings, they can be changed however:  
Norm.environ., Quiet environ., Noisy environ., Car kit, Headset
- You may set two personal profiles individually (<No Title>).
- The special profile **Without Alarm** is fixed and cannot be changed (page 61).

If the phone is used by several people, they can each activate their own settings by selecting their personal profile.

## Activate

**Menu** → Profiles



Select default profile, personal profile.

**Select**

Activate the profile.

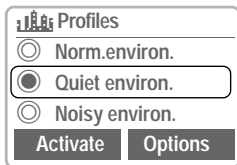

- Highlights the active profile.

## Setup

Edit a default profile or create a new personal profile:



Select profile.

**Select**

Confirm.

## Profiles-Menu

**Options**

Open menu.

<b>Activate</b>	Activate the current profile.																		
<b>Edit</b>	The following functions can each be set individually for a profile: <table border="0"> <tbody> <tr> <td>Ringer setting</td> <td>page 65</td> </tr> <tr> <td>Volume</td> <td>page 65</td> </tr> <tr> <td>Melodies</td> <td>page 65</td> </tr> <tr> <td>Silent alert</td> <td>page 65</td> </tr> <tr> <td>Filter</td> <td>page 65</td> </tr> <tr> <td>Information tones</td> <td>page 65</td> </tr> <tr> <td>Key tones</td> <td>page 65</td> </tr> <tr> <td>Big letters</td> <td>page 69</td> </tr> <tr> <td>Illumination</td> <td>page 69</td> </tr> </tbody> </table> <p>When you have finished setting a function you return to the profile menu where you can change a further setting.</p>	Ringer setting	page 65	Volume	page 65	Melodies	page 65	Silent alert	page 65	Filter	page 65	Information tones	page 65	Key tones	page 65	Big letters	page 69	Illumination	page 69
Ringer setting	page 65																		
Volume	page 65																		
Melodies	page 65																		
Silent alert	page 65																		
Filter	page 65																		
Information tones	page 65																		
Key tones	page 65																		
Big letters	page 69																		
Illumination	page 69																		
<b>Rename</b>	Rename the selected profile.																		
<b>Copy from</b>	Copy settings from another profile.																		

## Car kit

If an original Siemens Car Kit is used the profile is activated automatically as soon as the phone is inserted into the cradle (see also page 78).

## Headset

If an original Siemens Headset is used the profile is activated automatically as soon as the headset is plugged in (see also page 78).

## Without Alarm

All alarms are deactivated. It is not possible to modify this profile.

- The phone must be switched off when you select a profile.
- In this status, alarms are **not** indicated by the ringer or trembler alarm.

## Activate

**Menu** → Profiles



Select **Without Alarm**.

**Select**

Activate the profile.

Profile selection must be confirmed.



Then switch off the phone, otherwise the phone switches itself off automatically after 30 seconds.

## Normal operation

The next time you switch on the phone and return to normal operation the default profile will be activated

**Menu** → Favourites

Combine your own menu with frequently used functions, phone numbers or WAP pages.

The list of the 10 entries available is preset. However you can change it according to your wishes.

For fast access:



Press then ...



.. press twice.

## Apply



Select the required entry.

**Select**

Press.



If the selected entry is a phone number, you can also call with the Call key.

## Change

You can replace each preset entry (1-10) with another entry from the list of your favourites.



Select the required entry.

**Options**

Press.

**Change settings**

Press.



Select the new entry in the selection list (see page 63).

**Set**

Press.

If you have selected a phone number or a WAP favourite as a new entry, the relevant application opens for the selection.

## Reset

After confirmation and after entering the phone code, the default entries are reset.



The left soft key and the keys 2 to 9 (speed dialling numbers) can each be assigned an important phone number or a function. The phone number can then be dialled or the function can be started at the touch of a button.

A function may already have been programmed on this soft key by your service provider (e.g. access to "SIM services"). This key assignment may be unmodifiable.

The soft key may sometimes be replaced with /OO to access a new message.

Key assignments available:

- Internet ..... page 35
- Phonebook/Addressbook page 18
- Phone number ..... page 64
- Calendar..... page 49
- Alarm clock ..... page 54
- Notes ..... page 53
- Calculator ..... page 55
- New SMS ..... page 29
- Illumination ..... page 69
- Hide ID..... page 75
- GPRS On/off !..... page 76
- IrDA ..... page 77
- Games ..... page 59
- Missed calls..... page 43
- Calls received ..... page 43
- Inbox ..... page 28
- Outbox..... page 28
- Pers.Favourites ..... page 62

## Left soft key

The **left** soft key can be used for fast access.

### Edit

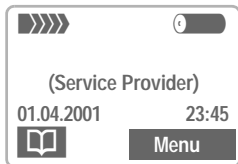

Press (if not preset differently).

### Edit

Scroll to the application in the list.

- Assign the new application (e.g. **Games**) to the soft key.
- Special case **Phone number**. Pick out a name from the Phonebook/Addressbook (e.g. "Carol") to assign the soft key.

### Select

Confirm setting.

## Apply

The setting "Carol" is used here only as an example.

### Carol

Hold **down**.

## Speed dialling numbers

Number keys 2 to 9 can be used as speed dialling numbers for fast access. For available key assignments see page 63.

The following key is reserved:

 = mailbox number (page 40)

## Edit

In standby mode:



Press number key (2-9).  
If the key is not assigned:

**Set**

Press.

**or**

**Games**

press **briefly** (if assigned with e.g. "Games").

**Edit**

Scroll to the application in the list.

Special case **Phone number**. Scroll to a name in the Phonebook/Addressbook for assignment to the key.

**Select**

Confirm setting.

Special case **Internet**. Scroll to an URL in the bookmark list for assignment to the key.

**Select**

Confirm setting.

## Apply

Select a stored phone number or start a stored application (e.g. Games).

In standby mode:

 Press.

The assignment of number key 2 is displayed instead of the left soft key, e.g.:

**Games**

hold **down**

**or simply**

 hold **down**

## Quick menu selection

All menu functions are numbered internally. The relevant sequence of numbers is shown in the upper right corner of the display.

Enter the appropriate sequence of numbers to select a function directly.

For example, to compose a new SMS:

**Menu**

Press.

 For Messages

 For New SMS



**Menu** → Audio →  
then select a function:

## 1 minute beep

During a call you hear a beep after every minute as a reminder of the time elapsed.

## Melodies

You can choose from 38 melodies and additionally use four melodies that you have composed/stored yourself.



First select the type:

All calls  
 Calls  
 VIP Calls  
 Event  
 Messages  
 Cell broadcast services



Then select the melody.

**OK** Confirm.

## Melody manager

You can use this function to manage your melodies.

**Menu** → Surf & fun → Melody manager

### Load

Load melody from Own 1 - Own 4 or from the Explorer.

### Melody manager

Open.

**Options** Open menu.

**Load** Select and assign storage location.

### Save

Store loaded melody on Own 1 - Own 4 or on the Explorer (\*.mid).

**Play** The melody can be played.

## Receive melody

A melody can be sent to your phone via infrared, SMS or WAP.

When a melody has been received an icon appears above the left soft key.

Press this key to start the melody manager.

Ringtones, operator bitmaps, screensavers and other services for your Siemens Mobile Phone can be found at:

<http://www.my-siemens.com/city>

## Melody manager Menu

**Options** Open menu.

Play	Play the current melody.
Save as...	Store melody on Individual 1 - Individual 4 or on the Explorer (*.mid).
Send via ...	(page 82)
Load	Load melody from Individual 1 - Individual 4 or from the Explorer.
Discard	The current melody is deleted from the melody manager.
Delete	Delete the melody from the Individual 1 to Individual 4.

**Menu** → **Audio** →  
select a function:

## Compose melody

You can also compose one-voice melodies yourself.



Keys 1 to 7 correspond to the notes C, D, E, F, G, A, H.



Go back and forward in the melody by one note.



Set note/pause half a tone higher/lower.



Increase length of note/pause length.



Reduce length of note/pause length.



Use the left side keys to set a note/pause one octave higher/lower.



Insert a pause.

**Options** The menu offers further functions:

**Play**, **Playback speed**, **Save**,  
**Insert note**, **Delete note**,  
**Delete**, **Load**

## Device

**Menu** → Setup →  
Device →  
Select a function.

## Language

Set the language of the display text. When "automatic" is set the language of your service provider is used. If a language that you do not understand happens to be set, the phone can be reset to the language of your service provider with the following input:

\*#0000# 

## Display

### Own greeting

You can create a greeting that is displayed when you switch on the phone.

**Edit** Activate and deactivate.



Delete old message and compose new message.

**OK**

Confirm changes.

### Screensaver

The Screensaver shows a graphic on the display after a user-definable period of time, which the user can set. It protects the phone against unauthorised use, like the key lock (page 69). An incoming call or a long press on  and confirmation with **OK** will end the function.

You have the following options:

- Activate, deactivate the function.
- Set style: Special graphic, analogue clock
- Load graphic via **Bitmap viewer**.
- Test Screensaver.
- Set period after which the Screensaver starts.
- Activate password query as security setting.

**Menu** → Setup →  
Device →  
Select a function.

### Illumination

The display illumination can be switched on and off (this affects the standby time).

### Big letters

You can change the font size of the display.

### Contrast

Sets the display contrast level.

## Keys

### Any key to answer

You can answer incoming calls using any key (except ).

### Auto key lock

The keypad is automatically locked if one minute elapses since any key was last pressed. This prevents the phone from being used accidentally. However, you can still be called and you can still make an emergency call.

The keypad can also be directly locked and unlocked.



Hold **down**.



Confirm (only when the phone is being switched off).

### Key tones

You can set the type of the key tone:

Click or Tone or Silent

## Status

### Factory settings

The phone is reset to the default values (does not apply to SIM card or network settings).

### Phone identity

The phone identity number (IMEI) is displayed. This information may be useful for customer service.

### Fast search

Network reconnection is speeded up when this function is active (standby time is reduced).

## T9 input

### T9 preferred

Activate intelligent text entry or deactivate it.

### T9 language

Select language in which the message is to be composed.



## Security

The phone and SIM card are protected against misuse by several security codes and should be treated with the same care as a cheque guarantee card.

**Keep these confidential numbers in a safe place where you can access them again if required.**

<b>PIN</b>	Protects your SIM card (personal identification number).
<b>PIN 2</b>	This is needed to set the charge detail display and to access additional functions on special SIM cards.
<b>PUK</b>	Key code. Used to unlock SIM cards after the wrong PIN has been entered.
<b>Phone-code</b>	Protects your phone. Must be entered at the first security setting (4 - 8 digits).

**Menu** → **Setup** →  
**Security** → then  
 select a function:

### Pin change

#### PIN control

The PIN is usually requested each time the phone is switched on. You can deactivate this feature but you risk unauthorised use of the phone.

Some service providers do not permit this function.

#### PIN

You can change the PIN to any 4-8 digit number (i.e. a number you may find easier to remember).



Enter **old** PIN.



Press.



Enter **new** PIN.



Repeat **new** PIN.

#### PIN 2

You can change the PIN 2 to any 4-8 digit number (displayed only if PIN 2 is available).

Proceed as with **PIN**.

#### Phonecode

You define and enter the phone code when you call up a phone code protected function for the first time. It is then valid for all functions.

You can change it to any 4-8 digit number.

#### Babysitter

(**Phonecode protected**)

Calls can only be made to **one** phone number that is dialled by holding **down** the left soft key (page 17).

**Menu** → Setup →  
Security →  
select a function:

**Only** 

(.074 Tf7(IN .1(2 prot .07ect .07e)-3.2(d)6.07))JF5 1 Tf"8.037 0 0 8.037 163.7

connection

**Menu** → Setup → Network →  
then select a function:

## Configuration

### Network info

The list of GSM networks currently available is shown.



Indicates forbidden service providers (depending on SIM card).

### Choose network

Network search is restarted. This is useful if you are **not** in your home network or want to register in a **different** network. The network info list is rebuilt.

### Auto network

Activate or deactivate, see also "Choose network" above.

If "Automatic network" is activated, the next network is dialled in the order of your "preferred service providers". Otherwise a different network can be selected manually from the list of available GSM networks.

### Preferred network

The service providers you prefer after your home service provider are displayed in this list (e.g. if there are several service providers that differ in price).

When this function is activated, the list that your home service provider proposes is displayed first. You can edit this as required:

**List** Display list of preferred networks.

- Create new entry:

<No Title> Select,

then scroll to an entry in the list of the service providers and confirm.

- Change/delete old entry:

Select existing entry and delete it or select an entry from the list of the service providers and confirm.

### Band selection

Select either GSM 900 and GSM 1800.



**Menu** → Setup → Network →  
then select a function:

## Barrings



Barring restricts the use of your SIM card (not supported by all service providers). You need a 4 digit password that your service provider supplies you. You may need to be registered separately for each barring.

### Outgoing access

All outgoing calls except emergency number 112 are barred.

### Outgoing international

Only national calls can be made.

### Outgo internat. x home barred

International calls are not permitted. However you can make calls to your home country when abroad.

### All incoming calls

The phone is barred for all incoming calls (forwarding all calls to the mailbox has a similar effect).

### When roaming

You do not receive calls when you are outside your home network. This means that no charges are incurred for incoming calls.

## Status check

The following information can be displayed after a status check:



Barring set.



Barring not set.



Status unknown (e.g. new SIM card).

## Clear all

All barrings are cleared.

## User group



**Menu** → Setup →  
User group

If offered by the service provider, this service enables groups to be formed. These have access for example to internal (company) information or special tariffs apply to them. Check with your service provider for details.

### User group

Activate or deactivate the function. "User group" must be deactivated for normal phone use (phone code, page 11).

### Select group

You may select or add groups other than the preferred groups (see below). The service provider supplies you with code numbers for the groups.

**Menu** → Setup →  
User group

### Outgo. access

In addition to network control for a user group, it is possible to set whether outgoing calls outside the group are permitted. If the function is deactivated, only calls within the group are permitted.

### Preferred group

If activated, only calls within this standard user group can be made (depending on the network configuration).

## During calls

**Menu** → Setup →  
During calls →  
select a function:

### Call waiting



If you are registered for this service, you can check whether it is set and you can activate or deactivate it (page 14).

### Hide ID



When you make a call, your number may be displayed on the recipient's display (depending on the service providers).

To suppress this display, you may activate the "Conceal ID" mode for the next call or for all subsequent calls. You may need to register separately with your service provider for these functions.

## Connectivity

**Menu** → **Setup** →  
**Connectivity** →  
 select a function:

### GPRS



(**G**eneral **P**acket **R**adio **S**ervice)

GPRS is a new method to transmit data in the mobile network faster. If you use GPRS, you can be connected to the Internet permanently if the network capacities suffice. Advantages of GPRS are e.g.:

- WAP information is transmitted faster.
- You can chat without long delays.

This service is not yet supported by all service providers.

### Switch on/off



Activate or deactivate GPRS function for all relevant applications.

### GPRS info

Display of information on the connectivity status.



Fast access in standby mode.

## Data services

Select **Browser** (page 37). Select the required profile from the list.

Select **GPRS settings** or **CSD settings**:

<b>GPRS settings</b>	<b>APN:</b> Enter the address of your service provider.  <b>Login name:</b> Enter login name.  <b>Password:</b> Enter password (shown as a series of asterisks)
<b>CSD settings</b> (CSD = Circuit Switch Data)	<b>Dial-up no.:</b> Enter ISP number.  <b>Call type:</b> Select ISDN or Analog.  <b>Login name:</b> Enter login name.  <b>Password:</b> Enter password (shown as a series of asterisks)

In order to ensure optimum data flow when the telephone is connected to a computer by cable, please use only original accessories for ME45:

Data Cable Professional with the order number: S30880-S4501-A801-1 or S30880-S4501-A802-1.

**Menu** → Setup →  
Connectivity →  
select a function:

## IrDA(infrared)

The infrared port integrated in the phone cannot be used unless the other device has a corresponding port. Align the infrared windows with each other (max. distance 30 cm).

**Edit** Activate/deactivate IrDA.

Indicator on the display:



If switched on.



During transmission.

## Fax/data mod.

See page 81.

## Baud rate

You can use the baud rate to set the transmission rate in a cable connection between your PC and the phone:

115,2 Kbit/s

57,6 Kbit/s

38,4 Kbit/s

19,2 Kbit/s

## Authentication

Encrypted WAP dial-up.

## Time/date

This function is identical to **Time/date** on page 57.

**Menu** → Setup →  
Time/date

The clock must be set correctly once at start-up.

**Edit**

Press.



First date  
(day/month/year), then  
time (24 hours including  
seconds).

## Accessories

**Menu** → Setup → Accessories → select a function:

### Headset

If an original Siemens Headset is used the profile is activated automatically as soon as the headset is plugged in.

#### User-definable settings:

**Auto answer**  
(factory default: off)

Calls are automatically accepted after the 3rd ring. You should beware using the Headset.

#### Switch between the phone and the Headset

Switch to Headset during a call (if the phone is connected to the Headset).



Activate and deactivate.

#### Automatic settings:

- Accept call with the Call key or PTT key (Push To Talk) when the key lock is activated.
- Activate voice dialling with the PTT key.

### Car kit

If an original Siemens Car Kit is used the profile is activated automatically as soon as the phone is inserted into the cradle.

#### Modifiable settings:

##### Auto answer

(factory default: on)

Calls are accepted after the 3rd ring. Depending on the setup the ignition may need to be switched on.



Indication on the display.

##### Auto phone off

(factory default: 2 hours)

The phone is powered by the car's power supply. The time between switching off the ignition and deactivation of the phone can be adjusted.

#### Automatic settings:

- Permanent illumination: Switched on,
- Auto key lock: Switched off,
- Charge the phone battery,
- Automatically activate Car Kit, when the phone is inserted.

### HomeStation

These functions are only available with the appropriate original Siemens accessories (page 89).



To organise your files you can use the Explorer like a PC file manager. The Explorer assigns special folders to different data types:

**Menu** → Surf & fun → Explorer

A list of the folders and files is displayed.

Navigate through this list as usual using the menu navigation key:



Scroll up and down.



Go back from folder.

To open a highlighted file:

**Open** Open menu.

**Start** Select; the relevant application is started.

<b>Bitmap</b> Start Bitmap viewer (page 69).	*.bmp
<b>Melodies</b> Start melody manager (page 66).	*.mid
<b>SMS</b> SMS messages (Out), SMS messages (In). The messages are displayed in the editor.	*.smo *.smi
<b>Voice memo</b> Use the dictaphone to play back voice memos (page 47).	*.vmo
<b>Businesscard</b> Stored in vCard format.	*.vcf

<b>Alarm</b> Stored in vCalendar format	*.vcs
<b>Miscellaneous</b> Other files.	*.*

## Explorer menu

**Options** Open menu

Depending on whether you have highlighted a **file** or a **folder**, you are offered **different** functions.

<b>Open</b>	Open folder.
<b>Start</b>	Start application according to the file format.
<b>Mark/Unmark</b>	Highlight files/remove highlighting.
<b>Delete</b>	Delete all highlighted files.
<b>Delete all</b>	Delete all files. PIN must be entered.
<b>New folder</b>	Create a new folder and give a name to it (the folder must be on the same level).
<b>Rename</b>	Rename a highlighted file.
<b>Send via ...</b>	(see page 82)
<b>Sort</b>	Set sort criteria (alphabetical, type, time).
<b>Attributes</b>	Display information on the file or folder selected.
<b>Drive info</b>	Display the capacity used and available.

## Siemens Quick Sync

This PC program can be used to synchronise addresses and appointments between your phone and Windows® Outlook® 98 or later versions.

### Software installation

Insert the CD ROM into the drive of your PC and select "Siemens Quick Sync". You will be guided through the installation process by dialogue boxes.

### Operating instructions

The Siemens Quick Sync Software offers detailed operating instructions and online help. You can call up help by clicking on "?" in the menu bar.

### Connection

Phone and PC must be interconnected via infrared or a cable.

## Flexible memory

The memory of your phone (approx. 400 KBytes) is used flexibly by various applications and adapts itself to your personal user profile.

The applications available are:

Explorer

Addressbook

Dictaphone

SMS Archive

Melodies

Pictures

**Always delete data not needed any more.**

**Menu** → Setup →  
Connectivity →  
Fax/data mod.

With the phone connected to a PC, you can transmit and receive faxes and data. Appropriate software for data communication/fax communication must be available on your PC and there must be a connection (e.g. IrDA, page 77) to the phone.

Fax and data services must be enabled by the service provider. Different networks support different types of fax/data reception, contact your service provider for details.

## Fax/data mod.

Your service provider must give you a number for telephoning and a fax/data number.

### Sending

Start your PC communication program and enter the required destination phone number in the program.

### Receiving

The call is signalled by a special ringer and the type (fax or data) is displayed.

Now start the communication program in your PC to receive the fax/data.

## Speech/fax

### Send

**Menu** → Setup →  
Connectivity →  
Fax/data mode →  
Send vce/fax

Set this function on the phone **before** transmission so that you can switch from voice mode to fax mode.

While the connection is being set up, the following soft key is available for two seconds:

**Voice/fx** Switch to **Send vce/fax** mode; you may now send a fax.

### Receive

(**Only** if a special fax or data number is not available).

Start the required communication program on your PC and switch on the function at the phone **during** the call (the PC accepts the connection).

**Menu** → Setup →  
Connectivity →  
Fax/data mode →  
Voice/fax rec

### End transmission

End transmission in the PC software and/or press .

## Send via ...

The phone offers several options to transmit or receive messages and data via various transmission routes. The relevant option menus offer access to this function:

### SMS

Phonebook entries/Addressbook entries, appointments, memos etc. can be sent as an SMS to another suitable mobile phone.

Larger objects are split into several SMS messages, if necessary.

### IrDA





















The infrared port integrated in the phone cannot be used unless the other device has a corresponding port (see also page 77).

This device can be a mobile phone, PDA, PC or printer.

## Print via IrDA

Printing via the integrated infrared interface requires a suitable printer.

## Displays

	Strength of incoming signal.
	Charging completed.
	Battery indicator.
	All calls are diverted.
	Ringer off.
	Short ringer (beep) only.
	Ringer only if caller is stored in the Addressbook/Phonebook.
	Alarm is set.
	Key lock active.
*!*	Transmission unencrypted.
	Phone numbers/names:
	SIM Card.
	Phone memory.
	Restricted SIM Card.
	No network access.
	Line 1 active (of 2 lines).
	Function active.
?	Unknown network function.
	Auto Call answering on.
	Addressbook/Phonebook.
abc/ ABC	Indicates whether upper or lower-case letters are active.
T9	Text input <b>with</b> T9.
	WAP Offline.
	WAP Online.
	Infrared standby.

 Infrared transmission.

 Headset mode.

 Additional handset mode.

 HomeStation active.

 Car Kit active.

## Calendar icons

 Memo

 Meeting.

 Call.

 Birthday.

 Voice memo.

## Soft keys

 Message received.

 Voice mail received.

 Unanswered call.

 Store in Addressbook/  
Phonebook.

 SIM services.

 Switch to handset.

 T9 word selection.

 Store in archive.

Worldwide support by Siemens  
Partners is only phone call away or in  
the Internet:

Internet: <http://www.my-siemens.com>

Abu Dhabi	Siemens Service Center	0 26 42 38 00
Australia	Siemens	18 00 62 24 14
Argentina	Siemens	0 80 08 88 98 78
Austria*	Siemens	05 17 07 50 04
Bahrain	Siemens	40 42 34
Bangladesh	Siemens	0 17 52 74 47
Belgium	Siemens	0 78 15 22 21
Brunei	incomm	02 43 08 01
Bulgaria	Omnitel	02 73 94 88
Cambodia	Siemens	12 80 05 00
Canada	Siemens	1 88 87 77 02 11
China	Siemens	0 21 50 31 81 49
Croatia	Siemens	0 16 10 53 81
Czech Republic	Siemens	02 33 03 27 27
Denmark*	Siemens	35 25 86 00
Dubai*	Siemens	0 43 55 99 88
Egypt	Siemens	0 13 31 31 44
Estonia	Siemens	6 30 47 35
Finland*	Siemens	09 22 94 37 00
France*	Siemens	01 56 38 42 00
Germany*	Siemens	0 18 05 33 32 26
Greece	Siemens	0 16 86 43 89
Hong Kong	Siemens	22 58 36 36
Hungary	Siemens	06 14 71 24 44
Iceland	Smith & Norland	5 11 30 00
India	Siemens	01 16 92 39 88
Indonesia	Dian Graha Elektr.	02 14 61 50 81
Ireland*	Siemens	18 50 77 72 77
Italy	Siemens	02 66 76 44 00
Ivory Coast	Siemens	80 00 03 33
Jordan	Siemens	0 79 55 96 63
Kuwait	NGEEO	4 81 87 49

Latvia	Siemens	7 50 11 14
Lebanon*	F.A. Kettaneh	01 44 30 43
Libya	Siemens	02 13 35 02 31
Lithuania	UAB Skaidula	2 39 77 79
Luxembourg	Siemens	43 84 33 99
Malaysia	Siemens	03 79 52 51 84
Malta	Siemens	00 35 32 14 94 06 32
Mauritius	Ireland Blyth	2 11 62 13
Morocco	Setel S.A.	22 66 92 32
Netherlands*	Siemens	0 90 03 33 31 00
Norway*	Siemens	22 70 84 00
Oman	Siemens	79 10 12
Pakistan	Siemens	02 15 67 35 65
Philippines	Siemens	28 14 98 88
Poland	Siemens	08 00 22 09 90
Portugal*	Siemens	8 00 85 32 04
Qatar	Siemens	00 97 44 69 67 00
Russia	Siemens	09 57 37 29 51
Saudi Arabia	Siemens	0 26 51 50 94
Sharjah	Siemens	0 65 33 66 42
Singapore	Siemens	8 45 48 18
Slovak Republic	Siemens	07 59 68 22 66
Slovenia	Siemens	0 14 74 63 36
South Africa	Siemens	08 60 10 11 57
Spain	Siemens	9 02 11 50 61
Sweden*	Siemens	0 87 50 99 11
Switzerland	Siemens	0 12 12 00 90
Taiwan	Siemens	02 25 18 65 04
Thailand	Siemens	0 27 15 51 00
Tunisia	Siemens	01 86 19 02
Turkey	Simko	0 21 65 71 89 89
United Kingdom*	Siemens	0 87 05 33 44 11
USA	Siemens	1 87 76 87 16 71
Vietnam	Opticom	45 63 22 44
Zimbabwe	Siemens	04 36 94 24





### Original Siemens accessories

You can buy original Siemens accessories at <http://www.my-siemens.com>; in countries marked with an asterisk \*, you can also call the phone number shown.

If problems occur when using the phone, try to find a solution here first.

Problem	Possible causes	Possible corrective measures
Phone cannot be switched on.	On/Off key not pressed long enough.	

Problem	Possible causes	Possible corrective measures
No connection to network.	Signal weak.	Move higher, to a window or open space.
	Outside GSM range.	Check service provider coverage map.
	SIM card not valid.	Reclaim at the service provider.
	New network not authorised.	Try manual selection or select a different network (p. 73).
	Network barring is set.	Check barrings (p. 74).
Phone loses network.	Network overloaded.	Try again later.
	Signal too weak.	Reconnection to another service provider is automatic (p. 74). Switching the phone off and on again may speed this up.
Communication difficult in car with handsfree function.	Ambient noise level too high.	Use Car Kit (Car Solutions, p. 89)
Calls not possible.	Dialling error.	New network not authorised (p. 73).
	2nd line set.	Set 1st line  (p. 73).
	New SIM card inserted.	Check for new restrictions.
	Charge limit reached.	Reset limit with PIN 2 (p. 11).
	Credit used up.	Load credit.
Certain uses of the phone not possible.	Call restrictions are set.	Barrings may be set by your service provider. Check barrings (p. 72).
	The phone number has more than 20 digits.	Check phone number.
Entries cannot be made in Addressbook/Phonebook.	Addressbook/Phonebook is full.	Delete Addressbook/Phonebook entries (p. 22).
Voice mail does not work	Call diversion to the mailbox not set.	Set call diversion to the mailbox (p. 45).
SMS (text message)  flashes.	SMS memory full.	Delete messages (SMS) to make room (p. 30).
Function cannot be set.	Not supported by service provider or registration required.	Contact your service provider.
Charge counter does not work.	Charge pulse not transmitted.	Contact your service provider.



Problem	Possible causes	Possible corrective measures
Message cannot be sent.	Some service providers do not support this service.	Check with your service provider.
	Phone number of the service centre is not set or is wrong.	Set service centre (p. 33).
	SIM card contract does not support this service.	Contact your service provider.
	Service centre overloaded.	Repeat message.
	Addressee does not have a compatible phone.	Check.
PIN error.	Three wrong entries.	Enter the MASTER PIN (PUK) provided with the SIM according to the instructions. If MASTER PIN or PIN has been lost, contact your service provider.
Phone code error.	Three wrong entries.	Contact Siemens Service (p. 84).
Service provider code error.	No authorisation for this service.	Contact your service provider.
Too few/too many menu entries.	Functions may have been added or removed by your service provider via the SIM card.	Check with your service provider.
No fax possible.	Incorrect settings in the PC.	Check settings (p. 81).
	No authorisation for this service.	Contact your service provider.
	Wrong infrared driver in the PC.	Install latest infrared driver.
Damage		
Severe shock.	Remove battery and SIM and insert them again. Do not dismantle the phone.	

**Reset all settings to the factory default: \* # 9 9 9 9 #** 

Further information can be found on the Internet under:

<http://www.my-siemens.com/productservice>

## Declaration of conformity

Hereby, Siemens Information and Communication mobile, declares that the phone described in this user guide is in compliance with the essential requirements and other relevant provisions of European Directive 1999/5/EC.

The declaration of conformity (DoC) concerned has been signed. Please call the company hotline if you require a copy of the original.

The SAR recommendations of ICNIRP are met.

## Technical data

GSM class:	4 (2 Watt)
Frequency range:	880 - 960 MHz
GSM class:	1 (1 Watt)
Frequency range:	1,710 - 1,880 MHz
Weight:	99 g
Dimensions:	109x46x21 mm (76 ccm)
Operating voltage:	3.6 Volt
Operating temperature:	-10°C - 55°C
Standby time:	Up to 300 h.
Talk time:	Up to 6 h.
SIM card:	1.8/3 Volt

## Maintenance tips

- The SIM card should be treated with the same care as a cheque guarantee card. Do not bend or scratch it or expose it to static electricity.
- Clean the card with a damp cloth or an anti-static wipe without chemical cleaning agents.
- Protect the phone from moisture and shocks. Do not expose your phone to direct sunlight.
- Remove the battery if you are not going to use the phone for extended periods of time (more than one month).

### Phone ID

You will need the following details if you lose your phone or SIM card. Please enter here the number of the SIM card (on the card):

.....

15-digit serial number of the phone (under the battery):

.....

Customer Service number of the service provider:

.....

### Lost phone

If you lose your phone or SIM card, contact your service provider immediately to prevent misuse.

## Basics

**Li-Ion Battery (840 mAh):**

L36880-N4501-A101

**Travel Charger:**

L36880-N4001-A103 (Euro)

L36880-N4001-A104 (UK)

**Desk Top Charger:** L36880-N4501-A101

Enables simultaneous charging of the phone battery and a spare battery.

**Headset PTT:** L36880-N4001-A123

Optimum freedom of movement with excellent call quality. Including PTT (Push To Talk) key to accept calls and to activate voice dialling.

**Retractable Headset PTT:**

L36880-N4001-A160

**Car Charger:** L36880-N4001-A108**Mobile Holder:** L36880-N4501-A102**Mobile Holder Antenna:**

L36880-N4501-A103

Mobile holder for connecting an outdoor antenna. Ideal in combination with the Headset PTT or the Car Kit Portable.

**Carry Set:** L36880-N4501-A105

Features a belt clip and a clip for fastening the phone to clothes or bags.

**Basic Car Pack:** L36880-N4501-A107

Allows handsfree talking and simultaneously charges the mobile phone in the car.

**Leather Holster:** L36880-N4001-A154

**Belt Case:** L36880-N4801-A116

**Neoprene Case:** L36880-N4001-A155

**Grip Case:** L36880-N4501-A132

**Loop Case:** L36880-N4501-A133

**Leather Case:** L36880-N4501-A131

**Shoulder Bag:** L36880-N4001-A149

## Car Solutions

**Car Kit Portable:** L36880-N3015-A117

Handsfree kit with integrated loud-speaker, microphone and auto talk feature. Simply plug into the cigarette lighter socket. Ideal for mobility between vehicles.

**Car Kit Comfort:** L36880-N4501-A104

Handsfree kit with first-class digital call quality and operating convenience.

Includes all the components required for installation. The individual antenna solution can be obtained from your specialist dealer.

**Car Kit Professional Voice II**

L36880-N4501-A108 (German)

L36880-N4501-A109 (English)

L36880-N4501-A110 (French)

Handsfree kit with voice recognition, capacity for more than 100 names. Electronics box with connection for fax and e-mail transmission via your notebook.

Includes all the components required for installation. The individual antenna solution can be obtained from your specialist dealer.

**Car Kit GPServicePilot:**

L36880-N4501-A116

(can be obtained in Germany and Austria)

**Car Kit Upgrade:** L36880-N4501-A106

Cradle for upgrading your handsfree kit for the C25/28/35, M35, S25/S35, SL45 models.

**Optional Car Kit accessories**

- Car Handset:  
L36880-N3015-A123
- VDA Adapter Cable:  
L36880-N4001-A121
- Data Cable Professional:  
L36880-N3101-A112

**Data/Applications****Soft Data Link 5.0:** L36880-N4501-A115**Data Cable:** L36880-N3101-A102**Innovations****MP3-Player USB:** L36880-N4501-A114

Stereo headset for handsfree talking and superior sound quality when playing MP3 audio files. The 32 MB MultiMediaCard records 30 minutes of music in premium quality. The package includes the software for downloading and the USB connecting cables.

**HomeStation**

L36880-N4501-A118 (Germany)

L36880-N4501-A120 (Italy)

L36880-N4501-A122 (Spain)

L36880-N4501-A124 (France)

L36880-N4501-A126 (Great Britain)

L36880-N4501-A128 (Danmark)

L36880-N4501-A130 (Norway/Finland)

Connects the mobile phone to the fixed network, enabling automatic transfer of GSM calls to a phone.

GSM calls are diverted to the fixed network without additional charges and can be handled from there.

Products can be obtained in specialist shops. Visit our online shop under:



Original Siemens accessories

<http://www.siemens.com/mobilestore>

- A**
- Accessories ..... 89
  - Addressbook
    - call entry ..... 20
    - make entry ..... 18
    - Read/change an entry ..... 19
    - search entry ..... 19
  - Agenda ..... 49
  - Alarm clock ..... 52
  - Alarms missed ..... 52
  - Appointments ..... 50
  - Auto answer (in the car) ..... 78
  - Auto redial ..... 13
- B**
- Babysitter ..... 17
  - Band selection ..... 73
  - Baudrate ..... 77
  - Big letters ..... 69
  - Bitmap
    - load ..... 34
  - Bitmap viewer ..... 34, 69
  - Browser (WAP) ..... 36
  - Businesscard ..... 54
- C**
- Calculator ..... 55
  - Calculator functions ..... 55
  - Calender ..... 49
  - Call
    - accept/end ..... 12
    - charges ..... 44
    - divert ..... 45
    - holding ..... 15
    - menu ..... 16
    - not possible ..... 9
    - several simultaneously ..... 14
  - Call back ..... 13
  - Call divert ..... 45
  - Call lists ..... 43
  - Call transfer ..... 15
  - Calls dialled (call list) ..... 43
  - Calls missed (call list) ..... 43
  - Calls received ..... 43
  - Car accessories ..... 90
  - Car solutions ..... 89
  - CB services ..... 41
  - Change network ..... 73
  - Charge display ..... 44
  - Charging (battery) ..... 8
  - Clock ..... 57, 77
  - Conceal ID ..... 75
  - Conference ..... 15
  - Confidential numbers ..... 11, 71
  - Connection (2nd phone number) ..... 72
  - Connectivity ..... 76
  - Contrast (display) ..... 69
  - Control codes (DTMF) ... 16, 21, 24
  - Countdown ..... 58
  - CSD ..... 76
  - Currency conv. .... 56
- D**
- Daily view ..... 49
  - Date
    - set ..... 57, 78
  - Dictaphone ..... 14, 47
  - Display
    - big letters ..... 69
    - contrast ..... 69
    - illumination ..... 69
  - Display (settings) ..... 68
  - Divert ..... 45
  - DTMF tones ..... 16, 21, 24
- E**
- E-mail
    - via SMS ..... 33
  - Emergency call ..... 9
  - Explorer ..... 79
  - Extending numbers ..... 21

- F**
- Fast access ..... 63
  - Fast search ..... 70
  - Favorites ..... 62
  - Fax via SMS ..... 33
  - Fax/data mode ..... 81
  - Filter (for calls) ..... 65
  - Flexible memory ..... 80
  - Folder
    - create (Explorer) ..... 79
    - new (Explorer) ..... 79
- G**
- Games ..... 59
  - Getting started ..... 7
  - GPRS ..... 76
  - Greeting ..... 68
- H**
- Handset volume ..... 14, 16
  - Handsfree talking ..... 16
  - Headset ..... 78
  - Holding a call ..... 15
  - Home network ..... 73
- I**
- Illumination ..... 69
  - IMEI number ..... 70
  - In Car (accessories) ..... 61, 78
  - Information services ..... 41
  - Infrared (IrDA) ..... 77
  - International prefix ..... 12
- K**
- Key lock ..... 69
  - Key tone ..... 65
- L**
- Language (display) ..... 68
  - Limit (charge) ..... 44
  - Loss of phone, SIM card ..... 88
- M**
- Mailbox ..... 40
  - Mailbox (on the network) ..... 40
  - Maintenance of the phone ..... 88
  - Melody
    - compose ..... 67
    - load ..... 66
    - select ..... 66
  - Melody manager ..... 66
  - Menu
    - control ..... 6
    - speed dialling ..... 64
  - Message ..... 27
  - Message (SMS) ..... 27
  - Microphone off ..... 16
  - Monthly view ..... 49
- N**
- Network search ..... 70
- O**
- Outbox (SMS) ..... 28
- P**
- Phone data ..... 88
  - Phone identity number. (IMEI) ... 70
  - Phone memory ..... 23
  - Phone number selection ..... 72
  - Phonebook ..... 22, 63
  - Phonecode ..... 11, 71
  - PIN
    - change ..... 11, 71
    - enter ..... 9
    - error ..... 87
  - PIN 2 ..... 11, 71
  - Prefix ..... 19
  - Prefixes ..... 12
  - Prevent new SIM ..... 72
  - Print via ... 82
  - PUK ..... 11, 71

- R**
- Record number ..... 23
  - Redial ..... 13
  - Reminder ..... 13
  - Ringer setting ..... 65
- S**
- Search for an entry ..... 20
  - Security ..... 11
  - Send via ... ..... 82
  - Service centre ..... 33
  - Service tones ..... 65
  - Service tones, ringer ..... 65
  - Siemens service ..... 84
  - Silent alert ..... 65
  - SIM services ..... 10, 42
  - SMS
    - archive ..... 31
    - capacity ..... 28
    - delivery confirmation ..... 28
    - insert picture ..... 30
    - message type ..... 33
    - setup ..... 33
    - status report ..... 33
    - T9 input ..... 30, 53
  - Soft keys
    - set ..... 63
  - SOS ..... 9
  - Special characters ..... 31
  - Speech/fax ..... 81
  - Speed dialling numbers ..... 64
  - Standard values
    - reset ..... 70
  - Standby mode ..... 9
  - Standby time ..... 8
  - Stopwatch ..... 58
  - Swapping ..... 14
  - Switching off phone ..... 9
    - automatically ..... 57
  - Switching on phone ..... 9
- T**
- T9
    - switching on/off ..... 30, 53
    - text entry ..... 31
  - Technical data ..... 88
  - Text entry ..... 19, 31
  - Time zones ..... 57
  - Time/charge ..... 44
  - Time/date
    - set ..... 57, 77
  - Topic list (CB) ..... 41
  - Troubleshooting ..... 85
- U**
- Uppercase and lowercase ..... 31
  - User group (network) ..... 74
- V**
- Validity period (SMS) ..... 33
  - VIP group ..... 18
  - Voice command ..... 25
  - Voice dialling ..... 25
  - Voice memory ..... 14
  - Voice message ..... 40
  - Volume
    - handset ..... 14
    - ringer ..... 65
- W**
- WAP
    - access ..... 35
    - browser ..... 36
    - profiles ..... 37
    - setup ..... 37
  - Weekly view ..... 49

**Help**  
**SIM Services** (Optional)  
**Messages**

New SMS  
 Use SM-template  
 Inbox

SMS  
 Archive  
 Read new CB

Outbox

SMS  
 Archive

Voice message  
 Cell broadcast

Broadcast  
 Read new CB  
 Topic list  
 Auto display  
 Topic index  
 CB languages

Setup

SMS

Service Centre  
 Recipient  
 Message type  
 Validity period  
 Status report  
 Direct reply  
 SMS via GPRS

**Records**

Calls missed  
 Calls received  
 Calls dialled  
 Time/Charge

Last call  
 All calls out  
 Incoming calls  
 Remain. Units

Charge settings

Currency  
 Charge rate  
 Limit  
 All Calls  
 Incoming calls  
 Auto display

Erase records

**Office**

Addressbook  
 Phonebook

<Own>



<b>Office</b>	Organiser	Calendar Appointments Alarm Clock Tasks Notes Alarms missed
	Clock	Time zones Time/Date Format Date Auto display Auto Phone Off
	Businesscard Dictaphone Calculator Currency Conv. Voice control	
<b>Surf &amp; Fun</b>	Internet Games Stopwatch Countdown Bitmap viewer Melody manager Explorer	
<b>Profiles</b>	Norm. Environ. Quiet Environ. Noisy Environ. Car Kit Headset Without Alarm	
<b>Audio</b>	Ringer setting Volume	All calls 📖 Calls VIP Calls Event Messages Cell broadcast
	Melodies	All calls 📖 Calls VIP Calls Event Messages Cell broadcast
	Compose melody Filter Silent alert Key tones 1 Minute Beep Service tones	

## Divert

Unanswered  
All calls  
Specific divert

If n. reachable  
If no reply  
If busy

Receiving fax

## Setup

Network

Barrings

All calls out  
 Outgoing International  
 Out.Int.x Home  
 All calls in  
 When roaming  
 Status check  
 Clear all

User group

User group  
 Select Group  
 Outgo. Access  
 Preferred group

During calls

Call waiting  
 Conceal ID

Connectivity

GPRS  
 GPRS Info  
 IrDA  
 Data Services

Profiles

Fax/data mode

Send Speech/Fax  
 Receive Speech/Fax  
 Receive Fax/Data

Baudrate  
 Authentication

Time/Date

Time zones  
 Time/Date  
 Format Date  
 Auto display  
 Auto Phone Off

Accessories

Car Kit

Auto Answer  
 Aut. phone off

Headset

Auto Answer

Homestation

FN Access  
 CLIP

## Favorites