

# Washer-Extractors

Cabinet Hardmount  
S, P, and V-Series Microcomputers  
Coin and Non-Coin Models  
Refer to Page 2 for Model Identification

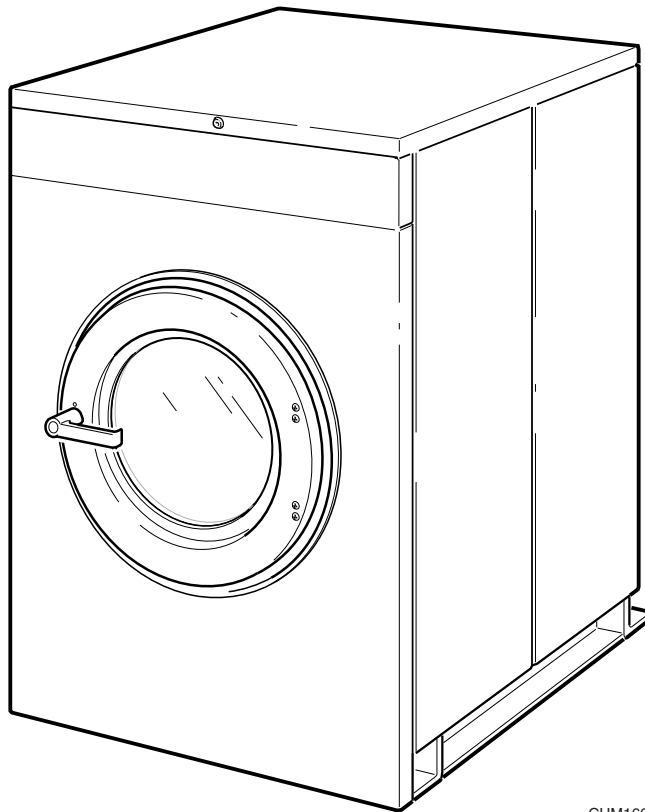

CHM166C

— Operation/Maintenance —

**Keep These Instructions for Future Reference.**

(If this machine changes ownership, this manual must accompany machine.)



[www.comlaundry.com](http://www.comlaundry.com)

Part No. F232137R4  
September 2008



# Table of Contents

<b>Introduction</b> .....	2
Model Identification .....	2
Nameplate Location.....	3
Replacement Parts .....	3
Customer Service.....	3
<b>Safety Information</b> .....	4
Explanation of Safety Messages .....	4
Important Safety Instructions .....	4
Safety Decals .....	6
Operator Safety .....	7
<b>Operation</b> .....	8
Control Panel .....	8
Display Indications .....	9
Operating Instructions .....	14
<b>Maintenance</b> .....	16
Daily .....	16
Beginning of Day .....	16
End of Day .....	16
Weekly .....	17
Monthly.....	17
Quarterly .....	20
Care of Stainless Steel .....	22

© Copyright 2008, Alliance Laundry Systems LLC

All rights reserved. No part of the contents of this book may be reproduced or transmitted in any form or by any means without the expressed written consent of the publisher.

# Introduction

## Model Identification

Information in this manual is applicable to these models:

HC18PC2	HC35VNV	NC18VC2	SC35PC3	UC18PC3	UC40VNV
HC18SN2	HC35VX2	NC18VX2	SC35SN2	UC18PN2	UC50PC2
HC18VC2	HC40SN2	NC25VC2	SC35VN2	UC18VN2	UC50PC3
HC18VX2	HC40VC2	NC25VX2	SC35VNV	UC18VNV	UC50PN2
HC20SN2	HC40VX2	NC27VC2	SC40VN2	UC20PN2	UC50VN2
HC20VC2	HC50PC2	NC27VX2	SC40VNV	UC20VN2	UC50VNV
HC20VX2	HC50SN2	NC35VC2	SC50PC3	UC25PC2	UC60PN2
HC25PC2	HC50VC2	NC35VX2	SC50SN2	UC25PN2	UC60SN2
HC25SN2	HC50VNV	NC80VCV	SC50VN2	UC27PN2	UC60VN2
HC25VC2	HC50VX2	NC80VXV	SC50VNV	UC27VN2	UC60VNF
HC25VX2	HC60SN2	SC18PC3	SC35PC3	UC27VNV	UC60VNV
HC27SN2	HC60VC2	SC18SN2	SC60PN2	UC30PN2	UC80PC2
HC27VC2	HC60VN2	SC18VN2	SC60SN2	UC30VN2	UC80PC3
HC27VX2	HC60VNF	SC18VNV	SC60VN2	UC35PC2	UC80PN3
HC30SN2	HC60VX2	SC20VN2	SC60VNF	UC35PC3	UC80VNV
HC30VC2	HC80PC3	SC25SN2	SC60VNV	UC35PN2	UC125VN
HC30VX2	HC80SN3	SC27SN2	SC80SN3	UC35VN2	
HC35PC2	HC80VCV	SC27VN2	SC80VNV	UC35VNV	
HC35SN2	HC80VNV	SC27VNV	SC125VNV	UC40PN2	
HC35VC2	HC80VXV	SC30VN2	UC18PC2	UC40VN2	

## Nameplate Location

The nameplate is located at the rear of the machine and inside door. Always provide the machine's serial number and model number when ordering parts or when seeking technical assistance.

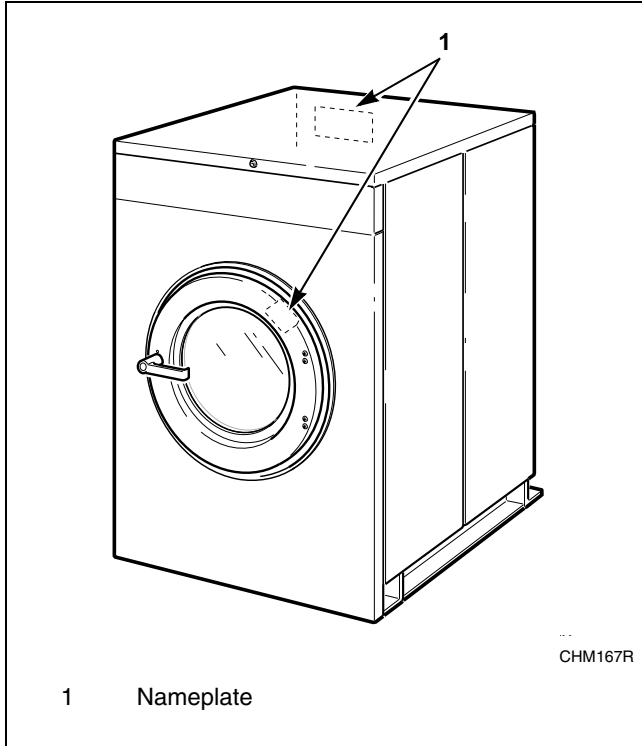

Figure 1

## Replacement Parts

If literature or replacement parts are required, contact the source from whom the machine was purchased or contact Alliance Laundry Systems at (920) 748-3950 for the name and address of the nearest authorized parts distributor.

## Customer Service

For technical assistance, call the following number:

(920) 748-3121  
Ripon, Wisconsin U.S.A.

# Safety Information

## Explanation of Safety Messages

Precautionary statements (“DANGER,” “WARNING,” and “CAUTION”), followed by specific instructions, are found in this manual and on machine decals. These precautions are intended for the personal safety of the operator, user, servicer, and those maintaining the machine.

	<b>DANGER</b>
<b>DANGER indicates the presence of a hazard that will cause severe personal injury, death, or substantial property damage if the danger is ignored.</b>	

	<b>WARNING</b>
<b>WARNING indicates the presence of a hazard that can cause severe personal injury, death, or substantial property damage if the warning is ignored.</b>	

	<b>CAUTION</b>
<b>CAUTION indicates the presence of a hazard that will or can cause minor personal injury or property damage if the caution is ignored.</b>	

Additional precautionary statements (“IMPORTANT” and “NOTE”) are followed by specific instructions.

**IMPORTANT:** The word “IMPORTANT” is used to inform the reader of specific procedures where minor machine damage will occur if the procedure is not followed.

**NOTE:** The word “NOTE” is used to communicate installation, operation, maintenance or servicing information that is important but not hazard related.

## Important Safety Instructions

	<b>WARNING</b>
<b>To reduce the risk of fire, electric shock, serious injury or death to persons when using your washer, follow these basic precautions:</b>	
W023	

1. Read all instructions before using the washer.
2. Refer to the **GROUNDING INSTRUCTIONS** in the **INSTALLATION** manual for the proper grounding of the washer.
3. Do not wash textiles that have been previously cleaned in, washed in, soaked in, or spotted with gasoline, kerosene, waxes, cooking oils, dry-cleaning solvents, or other flammable or explosive substances as they give off vapors that could ignite or explode.
4. Do not add gasoline, dry-cleaning solvents, or other flammable or explosive substances to the wash water. These substances give off vapors that could ignite or explode.
5. Under certain conditions, hydrogen gas may be produced in a hot water system that has not been used for two weeks or more. **HYDROGEN GAS IS EXPLOSIVE.** If the hot water system has not been used for such a period, before using a washing machine or combination washer-dryer, turn on all hot water faucets and let the water flow from each for several minutes. This will release any accumulated hydrogen gas. The gas is flammable, do not smoke or use an open flame during this time.
6. Do not allow children to play on or in the washer. Close supervision of children is necessary when the washer is used near children. This is a safety rule for all appliances.
7. Before the washer is removed from service or discarded, remove the door to the washing compartment.
8. Do not reach into the washer if the wash drum is moving.

9. Do not install or store the washer where it will be exposed to water and/or weather.
10. Do not tamper with the controls.
11. Do not repair or replace any part of the washer, or attempt any servicing unless specifically recommended in the user-maintenance instructions or in published user-repair instructions that the user understands and has the skills to carry out.
12. To reduce the risk of an electric shock or fire, DO NOT use an extension cord or an adapter to connect the washer to the electrical power source.
13. Use washer only for its intended purpose, washing textiles.
14. Never wash machine parts or automotive parts in the machine. This could result in serious damage to the basket.
15. ALWAYS disconnect the washer from electrical supply before attempting any service. Disconnect the power cord by grasping the plug, not the cord.
16. Install the washer according to the INSTALLATION INSTRUCTIONS. All connections for water, drain, electrical power and grounding must comply with local codes and be made by licensed personnel when required.
17. To reduce the risk of fire, textiles which have traces of any flammable substances such as vegetable oil, cooking oil, machine oil, flammable chemicals, thinner, etc., or anything containing wax or chemicals such as in mops and cleaning cloths, must not be put into the washer. These flammable substances may cause the fabric to catch on fire by itself.
18. Do not use fabric softeners or products to eliminate static unless recommended by the manufacturer of the fabric softener or product.
19. Keep washer in good condition. Bumping or dropping the washer can damage safety features. If this occurs, have washer checked by a qualified service person.
20. If the supply cord is damaged, it must be replaced by a special cord or assembly available from the manufacturer or its service agent.
21. Be sure water connections have a shut-off valve and that fill hose connections are tight. CLOSE the shut-off valves at the end of each wash day.
22. Loading door MUST BE CLOSED any time the washer is to fill, tumble or spin. DO NOT bypass the loading door switch by permitting the washer to operate with the loading door open.
23. Always read and follow manufacturer's instructions on packages of laundry and cleaning aids. Heed all warnings or precautions. To reduce the risk of poisoning or chemical burns, keep them out of the reach of children at all times (preferably in a locked cabinet).
24. Always follow the fabric care instructions supplied by the textile manufacturer.
25. Never operate the washer with any guards and/or panels removed.
26. DO NOT operate the washer with missing or broken parts.
27. DO NOT bypass any safety devices.
28. Failure to install, maintain, and/or operate this washer according to the manufacturer's instructions may result in conditions which can produce bodily injury and/or property damage.

**NOTE: The WARNINGS and IMPORTANT SAFETY INSTRUCTIONS appearing in this manual are not meant to cover all possible conditions and situations that may occur. Common sense, caution and care must be exercised when installing, maintaining, or operating the washer.**

Any problems or conditions not understood should be reported to the dealer, distributor, service agent or the manufacturer.

## Safety Information

	<b>WARNING</b>
<p>This machine must be installed, adjusted, and serviced by qualified electrical maintenance personnel familiar with the construction and operation of this type of machinery. They must also be familiar with the potential hazards involved. Failure to observe this warning may result in personal injury and/or equipment damage, and may void the warranty.</p>	
<small>SW004</small>	

**IMPORTANT:** Ensure that the recommended clearances for inspection and maintenance are provided. Never allow the inspection and maintenance space to be blocked.

	<b>WARNING</b>
<p>Install the machine on a level floor of sufficient strength. Failure to do so may result in conditions which can produce serious injury, death and/or property damage.</p>	
<small>W703</small>	

	<b>CAUTION</b>
<p>Be careful around the open door, particularly when loading from a level below the door. Impact with door edges can cause personal injury.</p>	
<small>SW025</small>	

	<b>WARNING</b>
<p>Never touch internal or external steam pipes, connections, or components. These surfaces can be extremely hot and will cause severe burns. The steam must be turned off and the pipe, connections, and components allowed to cool before the pipe can be touched.</p>	
<small>SW014</small>	

## Safety Decals

Safety decals appear at crucial locations on the machine. Failure to maintain legible safety decals could result in injury to the operator or service technician.

To provide personal safety and keep the machine in proper working order, follow all maintenance and safety procedures presented in this manual. If questions regarding safety arise, contact the manufacturer immediately.

Use manufacturer-authorized spare parts to avoid safety hazards.



## Operator Safety

	<b>WARNING</b>
<p><b>NEVER insert hands or objects into basket until it has completely stopped. Doing so could result in serious injury.</b></p> <p style="text-align: right;"><small>SW012</small></p>	

To ensure the safety of machine operators, the following maintenance checks must be performed daily:

1. Prior to operating the machine, verify that all warning signs are present and legible. Missing or illegible signs must be replaced immediately. Make certain that spares are available.
2. Check door interlock before starting operation of the machine:
  - a. Attempt to start the machine with the door open. The machine should not start with the door open.
  - b. Close the door without locking it and attempt to start the machine. The machine should not start with the door unlocked.
  - c. Close and lock the door and start a cycle. Attempt to open the door while the cycle is in progress. The door should not open.

If the door lock and interlock are not functioning properly, call a service technician.

3. Do not attempt to operate the machine if any of the following conditions are present:
  - a. The door does not remain securely locked during the entire cycle.
  - b. Excessively high water level is evident.
  - c. Machine is not connected to a properly grounded circuit.

Do not bypass any safety devices in the machine.

	<b>WARNING</b>
<p><b>Never operate the machine with a bypassed or disconnected balance system. Operating the machine with severe out-of-balance loads could result in personal injury and serious equipment damage.</b></p> <p style="text-align: right;"><small>SW039</small></p>	

# Operation

## Control Panel

Figure 2 shows the control panel for S, P and V-computer machines.

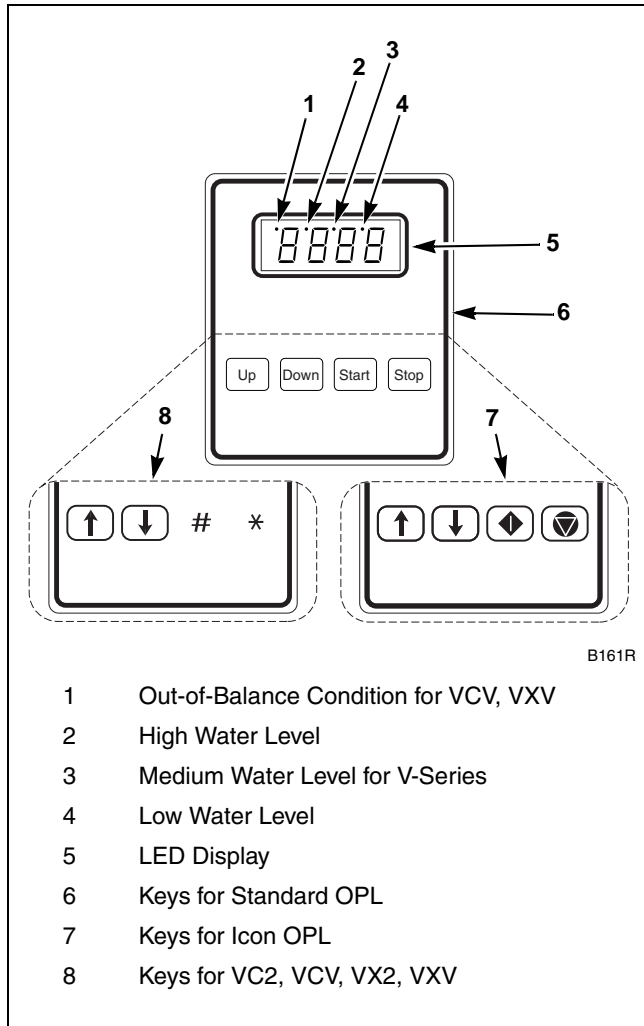





Figure 2

The **Up**  and **Down**  keys are used in cycle selection. Press these keys to move among cycles from smaller to greater, or greater to smaller.

The **Start** #  key is used to start a cycle.

The **Stop** \*  key is not active in normal RUN Mode. In RUN Mode it is used only for stopping test cycle.

The **LED display** informs operator of various functions throughout operation of machine. Refer to tables on the following pages for displays and their meanings. Indicator lights in LED display indicate out-of-balance conditions and water levels. Refer to *Figure 2*.

## Display Indications

Table 1 through Table 5 list the various displays and what they mean. The operator should become familiar with these computer displays.

Display Indications for S-Series – Non-Coin			
Display	Meaning	Display	Meaning
S-05	Program identification code (ROM) (this is an example only)	bFIL	Warm fill (both hot and cold)
HoLd	Wait...power has just been turned on	HFIL	Hot fill
CY	Cycle (followed by two-digit number)	LOLE	Low water level
CHEC/CYC*	Test cycle selected	HILE	High water level
FAr	Degrees Fahrenheit	SUP1	Supply 1
CEL	Degrees Celsius	SUP2	Supply 2
PrE	Prewash segment (1st of 8 segments)	SUP3	Supply 3
UASH	Wash segment (2nd of 8 segments)	SUP4	Supply 4
FIL1	First rinse (3rd of 8 segments)	SUP5	Supply 5 (supply 1 and 2)
FIL2	Second rinse (4th of 8 segments)	SUP6	Supply 6 (supply 2 and 3)
FIL3	Third rinse (5th of 8 segments)	SUP7	Supply 7 (supply 3 and 4)
FIL4	Fourth rinse (6th of 8 segments)	STOP	Stop routine
FIL5	Fifth rinse (7th of 8 segments)	SdLY	Spin coast delay
FIL6	Sixth rinse (8th of 8 segments)	dOnE	Cycle and stop routine have ended
CFIL	Cold fill	dOOr	Door not properly closed
SPIn/tInE*	Reads “SPIn” for one second, then “tInE” followed by time for spin	FILL/STOP*	Programmed water level not reached after 30 minutes
tSFL	Temperature sensor failure or temperature out of range	FULL	The computer detects low water level or higher when none should be present

\* Display indications separated by a slash (/) represent an alternating display.

Table 1

## Operation

### Display Indications

The following table lists the various displays and what they mean. The operator should become familiar with these computer displays.

Display Indications for P-Series – Coin			
Display	Meaning	Display	Meaning
Cn20	Program identification code (ROM)	HILE	High water level
Hold	Wait...power has just been turned on	SLUC*	Overflow fill
CY	Cycle (followed by two-digit number)	nobL	No Bleach selected
PUSH	Select cycle	bL	Bleach selected
FILL	Fill step	nSUP	No supply selected
bLCH	Add bleach	SUP	Supply selected
StOP	Stop routine	SUP1	Supply 1
SdLY*	Spin coast delay	SUP2	Supply 2
donE	Cycle and stop routine have ended	SUP3	Supply 3
PrE	Prewash segment (1st of 6 segments)	PrO	Programming Mode
UASH	Wash segment (2nd of 6 segments)	tESt	Test mode selected
rin1	First rinse (3rd of 6 segments)	norN	Run mode selected
rin2	Second rinse (4th of 6 segments)	FrEE	Vend price disabled
rin3	Third rinse (5th of 6 segments)	PAY	Vend price enabled
rin4	Fourth rinse (6th of 6 segments)	CoiL	Coin-blocking coil enabled
CFIL	Cold fill	S3	Supply 3 enabled
bFIL	Warm fill (both hot and cold)	1AtS	All 4 cycles share same vend price
HFIL	Hot fill	4AtS	Vend price may be set for individual cycles
LOLE	Low water level	Coin/dEno**	Set value assigned each coin
SPIn/tINE**	Reads “SPIn” for one second, then “tINE” followed by time for spin	dOOr	Door not properly closed

\* Machines shipped to France only.

\*\* Display indications separated by a slash represent an alternating display.

Table 2

Display Indications for V-Series – Coin			
Display	Meaning	Display	Meaning
FC 5	Program identification code (ROM) (this is an example only)	HFIL	Hot fill
		Lo	Low water level
HoLd	Wait...power has just been turned on	nEd	Medium water level
PAY/(price)*	Pay (flashes alternately with start price if “FLSH” SETUP option is enabled)	HI	High water level
		SUP0	No supplies
CYXX	Cycle (followed by two-digit number)	SUP1	Supply 1
tEst/CYC*	Test cycle selected	SUP2	Supply 2
FAr	Degrees Fahrenheit	SUP3	Supply 3
CEL	Degrees Celsius	SUP5	Supply 5 (supply 1 and 2)
HEAt	Auxiliary heat enabled	SUP6	Supply 6 (supply 2 and 3)
noHt	Auxiliary heat disabled	drAI/dISt*	Distribution (load balancing before extract) (Variable-speed only)
		drAI/For*	Drain step (low speed forward in test cycle)
Str/ANt*	Start amount – flashes briefly before showing vend price in SETUP Mode	SPIIn/tIME*	Reads “SPIn” for one second, then “tIME” followed by time for spin
		SdLY	Spin coast delay
Con1/deno*	Coin 1 value – flashes briefly before showing value of coin 1 in SETUP Mode	STOP	Stop routine
		donE	Cycle and stop routine have ended
Con2/deno*	Coin 2 value – flashes briefly before showing value of coin 2 in SETUP Mode	HI 1	Low spin in test cycle (Variable-speed only)
		HI 2	High spin in test cycle (Variable-speed only)
PrE	Prewash segment (1st of 8 segments)	bAL/FAIL*	Balance routine failed during test cycle
UASH	Wash segment (2nd of 8 segments)	SHUT/door*	Door not properly closed
FIL1	First fill (3rd of 8 segments)	CANt/OPEN*	Computer cannot unlock door after five attempts
FIL2	Second fill (4th of 8 segments)		
FIL3	Third fill (5th of 8 segments)	FILL/STOP*	Programmed water level not reached after 30 minutes
FIL4	Fourth fill (6th of 8 segments)		
FIL5	Fifth fill (7th of 8 segments)		
FIL6	Sixth fill (8th of 8 segments)	FULL	The computer detects low water level or higher when none should be present
AFIL	Auxiliary fill	dFLt	Drive fault detected (Variable-speed only)
bFIL	Warm fill (both hot and cold)	tSFL	Temperature sensor failure or temperature out of range
CFIL	Cold fill		
bLCH	Add bleach (for supply 2 only)	bAL?	Special factory balance SETUP Mode
1Pr	One vend price – all cycles	SPC?	Special factory Valve Flush Mode
16Pr	16 vend prices – one per cycle	SPIN	Spin in test cycle (2 speed only)
CHEC/CYC*	Test cycle selected (same as tEst/CYC)	rEv	Reverse wash speed in test cycle
For	Wash speed forward in test cycle		
FrEE	“Free” cycle option		

\* Display indications separated by a slash (/) represent an alternating display.

Table 3

## Operation

Display Indications for V-Series – Non-Coin			
Display	Meaning	Display	Meaning
FP 1	Program identification code (ROM) (this is an example only)	nEd	Medium water level
		HI	High water level
HoLd	Wait...power has just been turned on	SUP1	Supply 1
CY	Cycle (followed by two-digit number)	SUP2	Supply 2
tESt/CYC*	Test cycle selected	SUP3	Supply 3
FAR	Degrees Fahrenheit	SUP4	Supply 4
CEL	Degrees Celsius	SUP5	Supply 5 (Setup option)
HEAt	Auxiliary heat enabled	SUP6	Supply 6 (supply 1 and 5)
noHt	Auxiliary heat disabled	SUP7	Supply 7 (supply 3 and 4)
tFIL	Temperature-controlled fill enabled	SLo/For	Gentle wash speed, forward direction
ntFL	Temperature-controlled fill disabled	SLo/rEv	Gentle wash speed, reverse direction
CooL	Automatic cool-down enabled	norN/For	Normal wash speed, forward direction
noCL	Automatic cool-down disabled	norN/rEv	Normal wash speed, reverse direction
Ag 1	Agitation 1 selected (90% agitation)	drAI	Drain enabled
Ag 2	Agitation 2 selected (33% agitation)	nodr	Drain disabled
Ag 3	Agitation 3 selected (10% agitation)	dISt	Distribution (load balancing before extract)
Ag 4	Agitation 4 selected (6.7% agitation)	SPIn/tInE*	Reads “SPIn” for one second, then “tInE” followed by time for spin
AgSn	Agitation speed normal		
AgSL	Agitation speed low	SPn1	Lowest of three spins
PUNP	Pump output enabled (future use only)	SPn2	Middle of three spins
nPNP	Pump output disabled (future use only)	SPn3	Highest of three spins
PrE	Prewash segment (1st of 11 segments)	STOP	Stop routine
UASH	Wash segment (2nd of 11 segments)	SdLY	Spin coast delay
FIL1	First fill (3rd of 11 segments)	dOnE	Cycle and stop routine have ended
FIL2	Second fill (4th of 11 segments)	dFLt	Drive fault detected
FIL3	Third fill (5th of 11 segments)	dOOr	Door not properly closed
FIL4	Fourth fill (6th of 11 segments)	bAL/FAIL*	Balancing routine failed during test cycle after 10 attempts to balance load
FIL5	Fifth fill (7th of 11 segments)		
FIL6	Sixth fill (8th of 11 segments)	FILL/STOP*	Programmed water level not reached after 30 minutes
FIL7	Seventh fill (9th of 11 segments)		
FIL8	Eighth fill (10th of 11 segments)		
FIL9	Ninth fill (11th of 11 segments)	FULL	The computer detects low water level or higher when none should be present
CFIL	Cold fill	rotA	Computer detects possible rotation of motor when there should be none
bFIL	Warm fill (both hot and cold)		
HFIL	Hot fill	tSFL	Temperature sensor failure or temperature out of range
AFIL	Auxiliary fill (Setup option)		
Lo	Low water level		

\* Display indications separated by a slash (/) represent a flashing display.

Table 4

<b>Display Indications for V-Series – Non-Coin</b>			
<b>Display</b>	<b>Meaning</b>	<b>Display</b>	<b>Meaning</b>
F23n	Program identification code (ROM) (this is an example only)	FIL6	Sixth fill (8th of 11 segments)
		FIL7	Seventh fill (9th of 11 segments)
HoLd	Wait...power has just been turned on	FIL8	Eighth fill (10th of 11 segments)
CY	Cycle (followed by two-digit number)	FIL9	Ninth fill (11th of 11 segments)
tESt/CYC*	Test cycle selected	CFIL	Cold fill
FAR	Degrees Fahrenheit	bFIL	Warm fill (both hot and cold)
CEL	Degrees Celsius	HFIL	Hot fill
HEAt	Auxiliary heat enabled	AFIL	Auxiliary fill (Setup option)
noHt	Auxiliary heat disabled	Lo	Low water level
tFIL	Temperature-controlled fill enabled	nEd	Medium water level
ntFL	Temperature-controlled fill disabled	HI	High water level
CooL	Automatic cool-down enabled	SUP1	Supply 1
noCL	Automatic cool-down disabled	SUP2	Supply 2
Ag 1	Agitation 1 selected (90% agitation)	SUP3	Supply 3
Ag 2	Agitation 2 selected (33% agitation)	SUP4	Supply 4
Ag 3	Agitation 3 selected (10% agitation)	SUP5	Supply 5 (or Setup option)
Ag 4	Agitation 4 selected (6.7% agitation)	SUP6	Supply 6 (supply 1 and 5)
PUNP	Pump output enabled (future use only)	SUP7	Supply 7 (supply 3 and 4)
nPNP	Pump output disabled (future use only)	For	Wash speed, forward direction
PrE	Prewash segment (1st of 11 segments)	rEv	Wash speed, reverse direction
UASH	Wash segment (2nd of 11 segments)	drAI	Drain enabled
FIL1	First fill (3rd of 11 segments)	nodr	Drain disabled
FIL2	Second fill (4th of 11 segments)	STOP	Stop routine
FIL3	Third fill (5th of 11 segments)	SdLY	Spin coast delay
FIL4	Fourth fill (6th of 11 segments)	dOnE	Cycle and stop routine have ended
FIL5	Fifth fill (7th of 11 segments)	dOOr	Door not properly closed
FULL	The computer detects low water level or higher when none should be present	FILL/STOP*	Programmed water level not reached after 30 minutes
tSFL	Temperature sensor failure or temperature out of range	SPIIn/tInE*	Reads “SPIIn” for one second, then “tInE” followed by time for spin

\* Display indications separated by a slash (/) represent a flashing display.

Table 5

## Operation

### Operating Instructions

1. Turn on main power source (circuit breaker).

**For non-coin models:** Turn on the On/Off switch on the front panel to the On position. Refer to *Figure 4*.

2. Push button and turn handle clockwise to open. Refer to *Figure 3*.

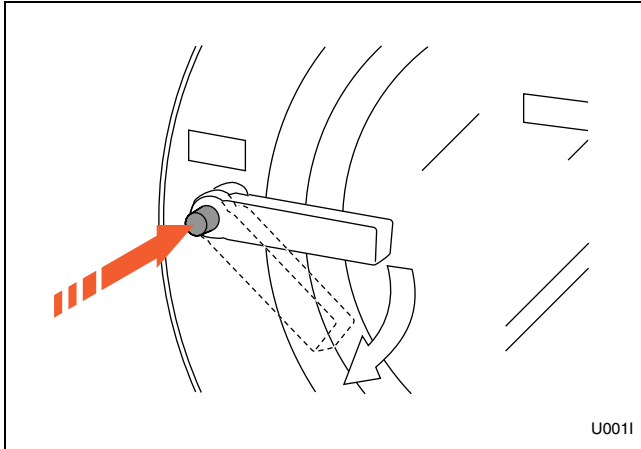

Figure 3

**For non-coin models:** Press and hold the DOOR UNLOCK button on the left side of the control panel while performing the above step. Refer to *Figure 3* and *Figure 4*.

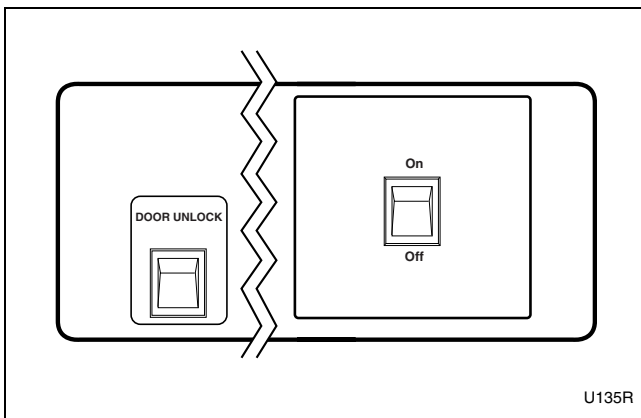

Figure 4

3. Load to capacity whenever possible. DO NOT OVERLOAD. Refer to *Figure 5*.

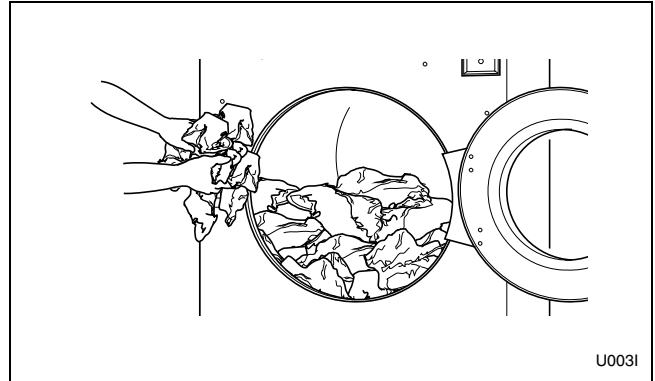

Figure 5

4. Close door and turn handle counterclockwise until button pops out. Refer to *Figure 6*.

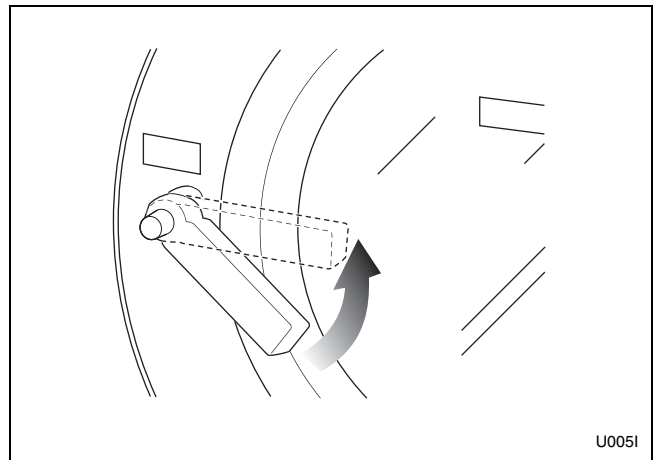



Figure 6



5. Add liquid and/or powder supplies to supply dispenser. Refer to *Figure 7*.
  - a. Add detergent to container 1.
  - b. Add softener to container 3.

**For non-coin models:** Liquid supplies may be injected directly into the supply dispenser by an external chemical supply dispenser. Refer to *Installation* and *Programming Manuals*.

6. Press the Up or Down key to select wash cycle. Press the Start key. Refer to *Figure 8*.

	<b>WARNING</b>
<p>To avoid personal injury, recommended inlet water temperature should be no higher than 125° Fahrenheit (51° Celsius).</p> <p style="text-align: right;"><small>W709</small></p>	

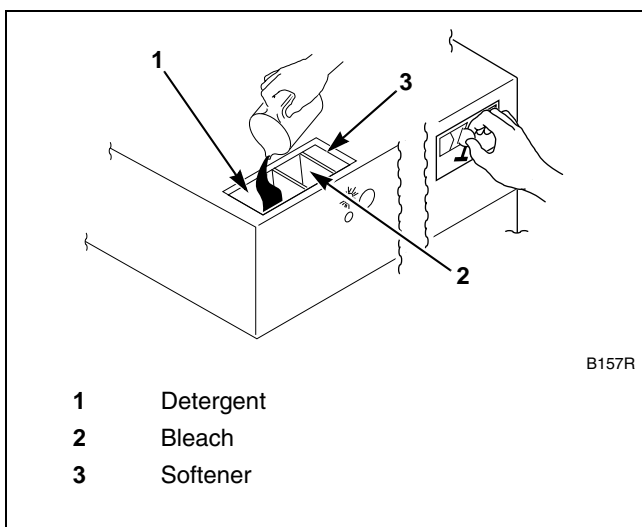

Figure 7

7. **For coin models:** Insert required number of coins to start machines. Refer to *Figure 7*.
8. **For non-coin models:** Press the Start key. Refer to *Figure 8*.

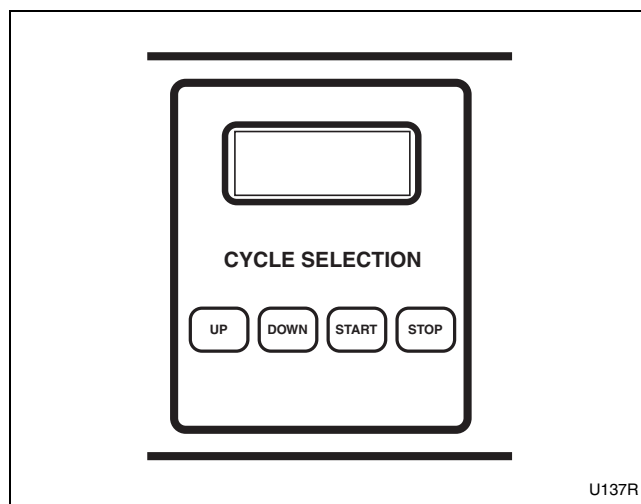

Figure 8

9. **When applicable,** add bleach to container 2 when the display reads “bLCH”. Refer to *Figure 9*.

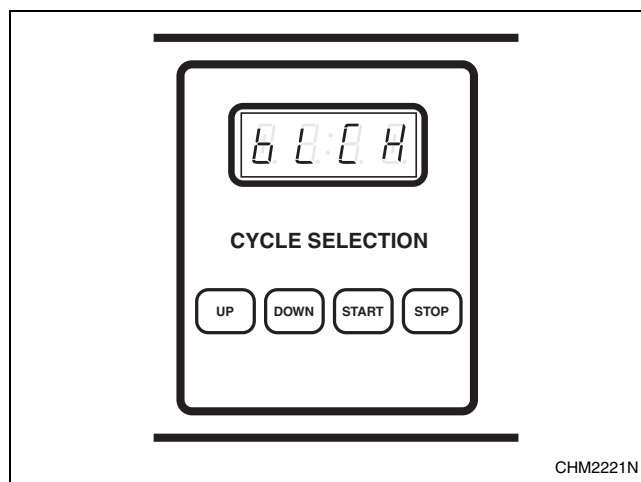



Figure 9

**NOTE:** To stop a cycle at any time, press the Stop (non-coin models only) key.

**NOTE:** To display the temperature of the water while a cycle is running, press the Up key. To display the number of the cycle in progress, press the Start key.

# Maintenance

	<b>WARNING</b>
<b>Sharp edges can cause personal injury. Wear safety glasses and gloves, use proper tools and provide lighting when handling sheet metal parts.</b>	
<small>W366R1</small>	

**IMPORTANT: Replace all panels that are removed to perform service and maintenance procedures. Do not operate the machine with missing guards or with broken or missing parts. Do not bypass any safety devices.**

## Daily

**IMPORTANT: Door lock should be checked daily to ensure proper operation. Also check that all safety and instruction labels are on the machine. Any missing or illegible safety instructions labels should be replaced immediately.**

## Beginning of Day

1. Inspect water inlet valve hose connections on the back of the machine for leaks.
2. Inspect steam hose connections for leaks (where applicable).
3. Check door interlock before starting operation:
  - a. Attempt to start the machine with the door open. The machine should not start with the door open.
  - b. Close the door without locking it and attempt to start the machine. The machine should not start with the door unlocked.
  - c. Close and lock the door, and start a cycle. Attempt to open the door while the cycle is in progress. The door should not open.

If the door lock and interlock are not functioning properly, call a service technician.

## End of Day

1. Clean the door gasket of residual detergent and all foreign matter.
2. Clean between the door gasket and the door glass with a damp cloth.
3. Clean automatic supply dispenser lid and general area. Flush dispenser with clean water.
4. Clean the machine's top, front and side panels with mild detergent. Rinse with clean water.
5. Leave loading door open at the end of each day to allow moisture to evaporate.

**NOTE: Unload the machine promptly *after each completed cycle* to prevent moisture buildup. Leave loading door open *after each completed cycle* to allow moisture to evaporate.**

## Weekly

1. For variable-speed models only, clean the AC drive box filter(s) weekly or more frequently as needed:

**NOTE: If fan filter service indicator light is on, fan filter must be cleaned immediately to prevent possible damage. Thermostat automatically resets after drive compartment cools down. LED will then extinguish after cycle run.**

**NOTE: If filter indicator is ignored, repeated resets might shorten life of drive. Clean filter regularly to avoid indicator prompt.**

- a. Open the top cover.
- b. Grasp the filter handle and pull straight up to remove filter.
- c. Wash the filter with warm water and allow filter to air-dry. As an alternative, the filter may be vacuumed clean.

**IMPORTANT: The control module cover and fan filter must be in place for the fan to properly cool the AC inverter drive. Failure to observe this warning will void the warranty and could lead to expensive AC inverter drive repair.**

2. Check the machine for leaks.
  - a. Start an unloaded cycle to fill the machine.
  - b. Verify that door and door gasket do not leak.
  - c. Verify that the drain valve is operating and that the drain system is free from obstruction. If water does not leak out during the first wash segment, the drain valve is closed and functioning properly.

## Monthly

**NOTE: Disconnect power to the machine at its source before performing the monthly maintenance procedures.**

1. Use the following procedures to determine if V-belt(s) require replacement or adjustment. Call a qualified service technician in either case.
  - a. Check V-belt(s) for uneven wear and frayed edges.
  - b. For groove-pulley drive systems, verify alignment by placing a straightedge across both pulley faces. The straightedge should make contact with the pulleys in four places. Refer to *Figure 10*.

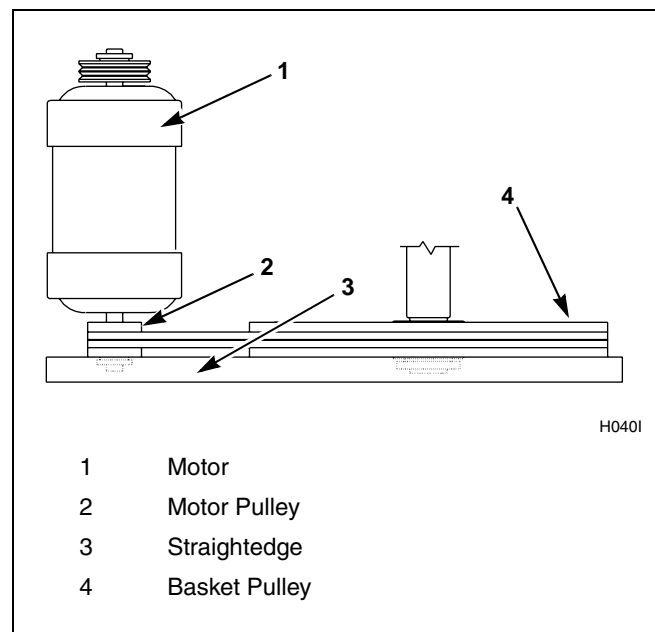

Figure 10

**Maintenance**

- c. For flat-pulley drive systems, verify allowable distance of belt from edge of pulley as shown in *Table 6* below:

Flat-Pulley Alignment	
Model	Allowable Distance from Edge
18 – 40	.09 in. (2 mm)
50 – 60	.38 in. (10 mm)

Table 6

- d. **For variable-speed models only**, verify that V-belts are properly tensioned by applying a set force to the belt and measuring the deflection to determine the belt tension. Refer to *Table 7* for the acceptable belt tension ranges. Belt tension measurements should be taken as close to the center of the belt span as possible. Refer to *Figure 11*.

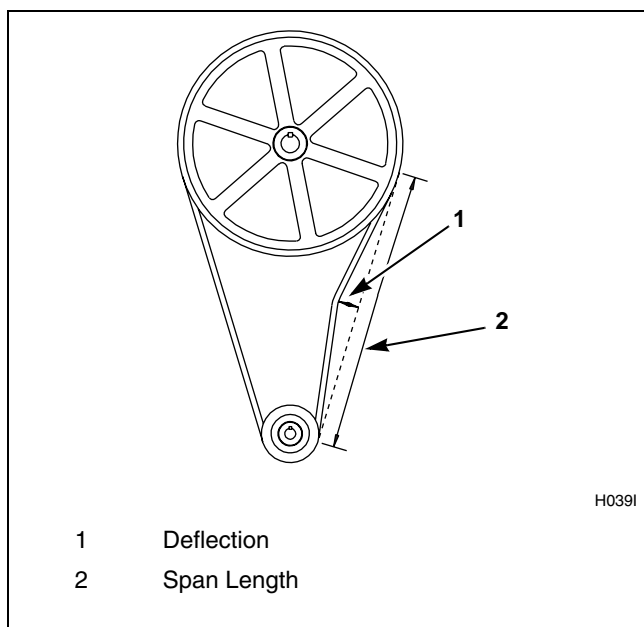

Figure 11

Belt Tension Testing for Variable-Speed Models				
Model	Belt	Belt Span	Deflection Range	Force Min – Max
35, 40	Motor-Basket	16.9 in. (428 mm)	.31 – .34 in. (7.9 – 8.7 mm)	6.1 – 7.4 lbs. (27 – 33 N)
50, 60	Motor-Basket	16.8 in. (426 mm)	.28 – .31 in. (7.1 – 7.9 mm)	6.1 – 7.4 lbs. (27 – 33 N)
80	Motor-Basket	22.1 in. (561 mm)	.47 – .5in. (11.9 – 12.7 mm)	4.9 – 7.3 lbs. (21.8 – 31.5 N)

Table 7

**NOTE: Hoses and other natural rubber parts deteriorate after extended use. Hoses may develop cracks, blisters or material wear from the temperature and constant high pressure they are subjected to.**

- 2. Check all hoses for any visible signs of deterioration. Any hose showing signs of deterioration listed above should be replaced immediately.

**NOTE: All hoses should be replaced every five years.**

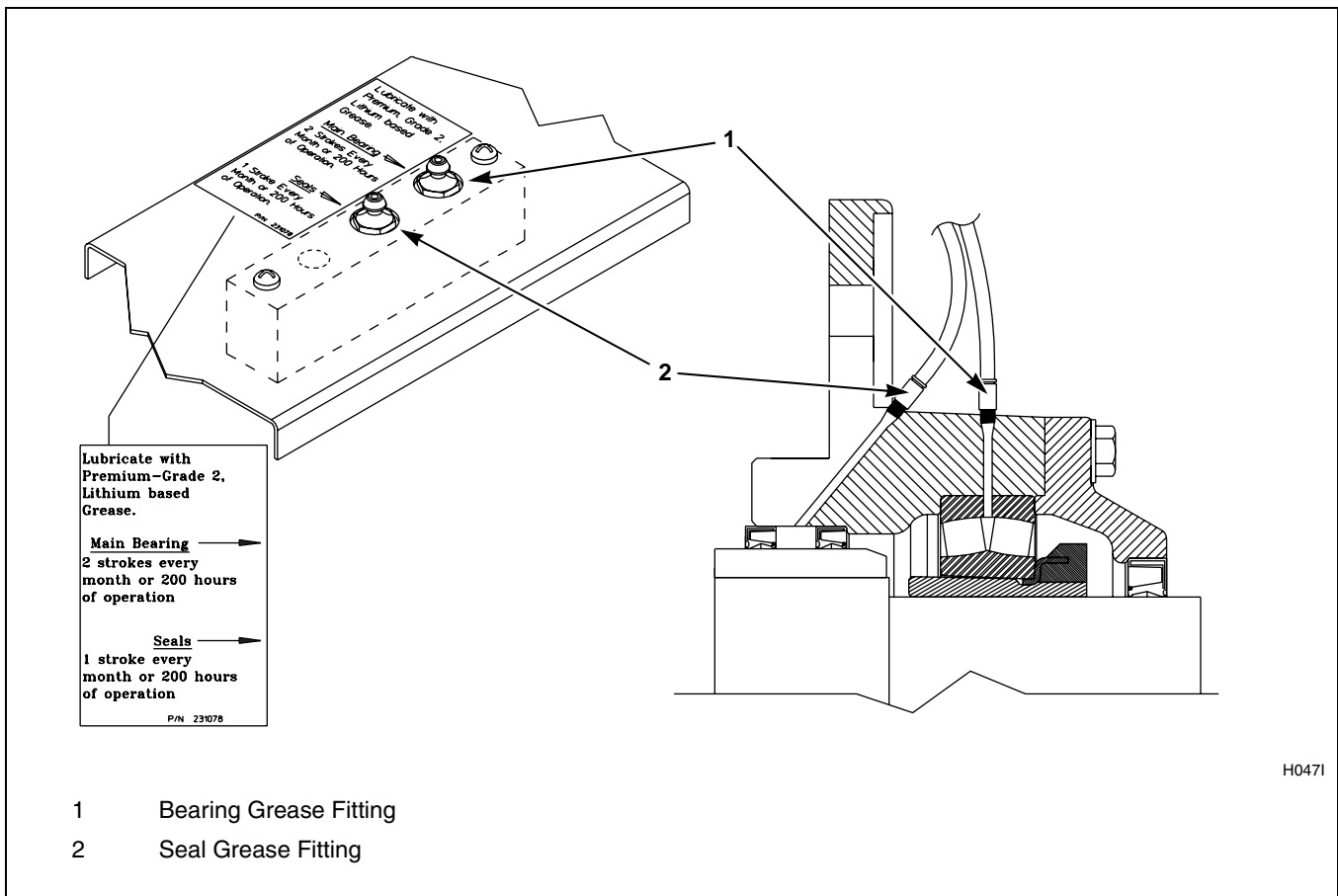

Figure 12

3. **For 80 pound capacity models only**, lubricate bearings and seals each month OR after every 200 hours of operation. Refer to *Figure 12*.
- Use a premium-grade lithium-based #2 grease. Never mix two types of grease, such as petroleum and silicone.
  - Pump the grease gun slowly, permitting only the following number of strokes:
    - Bearing grease fitting, two strokes
    - Seal grease fitting, one stroke

**NOTE: Do not pump the grease gun until grease comes out of the bearing housing. This can result in overlubrication, causing damage to bearings and seals.**

## Maintenance

4. Remove back panel, and check overflow hose and drain hose for leaks.
5. Unlock the hinged lid, and check the supply dispenser hoses and hose connections.
6. Clean inlet hose filter screens:
  - a. Turn water off and allow valve to cool, if necessary.
  - b. Unscrew inlet hose and remove filter screen.
  - c. Clean with soapy water and reinstall. Replace if worn or damaged.
7. Tighten motor mounting bolt locknuts and bearing bolt locknuts, if necessary.
8. Use compressed air to clean lint from motor.
9. Clean interior of machine, both basket and shell, by wiping with a water-soaked sponge or cloth.
10. Use compressed air to ensure that all electrical components are free of moisture and dust.
11. Verify the insulation is intact on all external wires and that all connections are secure. If bare wire is evident, call a service technician.
12. **For variable-speed models only**, clean AC drive cooling fan blades monthly (more often if required by the condition of the air).
  - a. Open the top cover and remove the control module cover.
  - b. Gently wipe the fan blades clean with a dry cloth.

## Quarterly

**NOTE: Disconnect power to the machine at its source before performing the quarterly maintenance procedures.**

1. Tighten door hinges and fasteners, if necessary.
2. Using a Teflon-based spray lube, lubricate the door lock by applying the spray to the door lock pin while turning the door handle.
3. Tighten anchor bolts, if necessary.
4. Verify that the drain motor shield is in place and secure.
5. Check all painted surfaces for exposed metal. (Matching paint is available from the manufacturer.)
  - If bare metal is showing, paint with primer or solvent-based paint.
  - If rust appears, remove it with sandpaper or by chemical means and paint with primer or solvent-based paint.

6. Clean customer-supplied steam filter, where applicable. Refer to *Figure 13*.
  - a. Turn off steam supply and allow time for the valve to cool.
  - b. Unscrew Cap.
  - c. Remove Element and clean.
  - d. Replace Element and Cap.

7. For variable speed and F-speed models only, measure the out-of-balance switch gap setting and adjust it as needed. The switch gap settings are listed in the *Installation* manual, which is supplied with the machine.
8. Check the bearing mounting bolts to make sure they are torqued properly. Refer to *Table 8* for specifications.

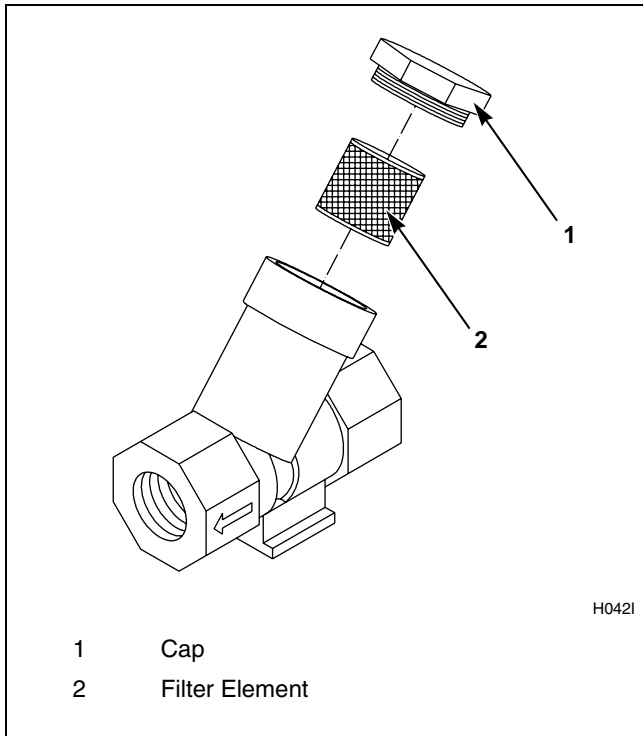

Figure 13

Machine Capacity	Bearing	Torque
18-25	All	75 ft.-lbs.
27-60	All	105 ft.-lbs.
80	Front	200 ft.-lbs.
80	Rear	97 ft.-lbs.
125	Front	500 ft.-lbs.
125	Rear	140 ft.-lbs.

Table 8

## Maintenance

### Care of Stainless Steel

- Remove dirt and grease with detergent and water. Thoroughly rinse and dry after washing.
  - Avoid contact with dissimilar metals to prevent galvanic corrosion when salty or acidic solutions are present.
  - Do not allow salty or acidic solutions to evaporate and dry on stainless steel. Wipe clean of any residues.
  - Rub in the direction of the polish lines or “grain” of the stainless steel to avoid scratch marks when using abrasive cleaners. Use stainless steel wool or soft, non-metal bristle brushes. Do not use ordinary steel wool or steel brushes.
  - If the stainless steel appears to be rusting, the source of the rust may actually be an iron or steel part not made of stainless steel, such as a nail or screw. Tip: Paint all carbon steel parts with a heavy protective coating. Stainless steel fasteners should be used whenever possible.
  - Remove discoloration or heat tint from overheating by scouring with a powder or by employing special chemical solutions.
- Do not leave sterilizing solutions on stainless steel equipment for prolonged periods of time.
  - When an external chemical supply is used, ensure no siphoning of chemicals occurs when the washer-extractor is not in use. Highly concentrated chemicals can cause severe damage to stainless steel and other components with the machine. Damage of this kind is not covered by the manufacturer’s warranty. Locate the pump below the washer-extractor’s injection point to prevent siphoning of chemicals into the machine.