

Washer-Extractors

Cabinet Freestanding

Refer to Page 2 for Model Identification

Installation

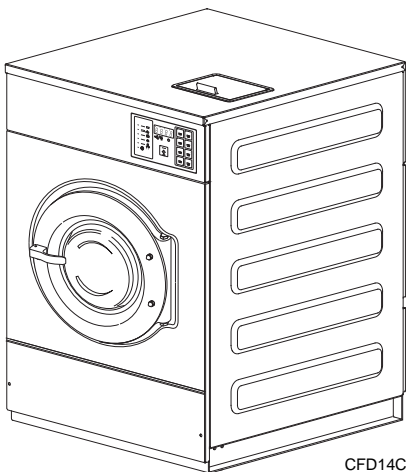

18 and 30 Models

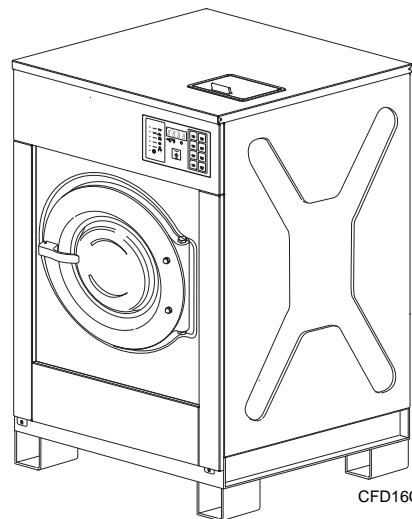

33 and 40 Models

Keep These Instructions for Future Reference.

(If this machine changes ownership, this manual must accompany machine.)



www.comlaundry.com

Part No. 9001909R4
December 2009

Table of Contents

Introduction	2
Model Identification	2
Nameplate Location.....	3
Replacement Parts	3
Customer Service.....	3
Safety Information	5
Explanation of Safety Messages.....	5
Important Safety Instructions	5
Safety Decals	7
Operator Safety	8
Specifications and Dimensions	9
Installation	15
Dimensional Clearances.....	15
Machine Foundation	15
Mechanical Installation.....	16
Frame Dimensions and Mounting Bolt Location.....	16
Mounting Bolt Installation (If Required).....	20
Removing the Transport Block.....	21
Drain Connection.....	22
Water Connection	23
Electrical Installation	24
Electrical Connection.....	24
Out-of-Balance Switch	26
Control Function Test	27

© Copyright 2009, Alliance Laundry Systems LLC

All rights reserved. No part of the contents of this book may be reproduced or transmitted in any form or by any means without the expressed written consent of the publisher.

Introduction

Model Identification

Information in this manual is applicable to these models:

18	NX18BVPA6 NX18BVPA7 NX18BVQA6 NX18BVQA7	NX18BVXA6 NX18BVXA7 NX18BVXM6 NX18BVXM7	SX18BVPA7 SX18BVQA7 SX18BVXA7 SX18BVXM7
30	NX30BVPA6 NX30BVPA7 NX30BVQA6 NX30BVQA7	NX30BVXA6 NX30BVXA7 NX30BVXM6 NX30BVXM7	SX30BVPA7 SX30BVQA7 SX30BVXA7 SX30BVXM7
33			SX33BVPA7 SX33BVQA7 SX33BVXA7 SX33BVXM7
40			SX40BVPA7 SX40BVQA7 SX40BVXA7 SX40BVXM7

Nameplate Location

The nameplate is located at the rear of the machine. Always provide the machine's serial number and model number when ordering parts or when seeking technical assistance. Refer to *Figure 1* and *Figure 2*.

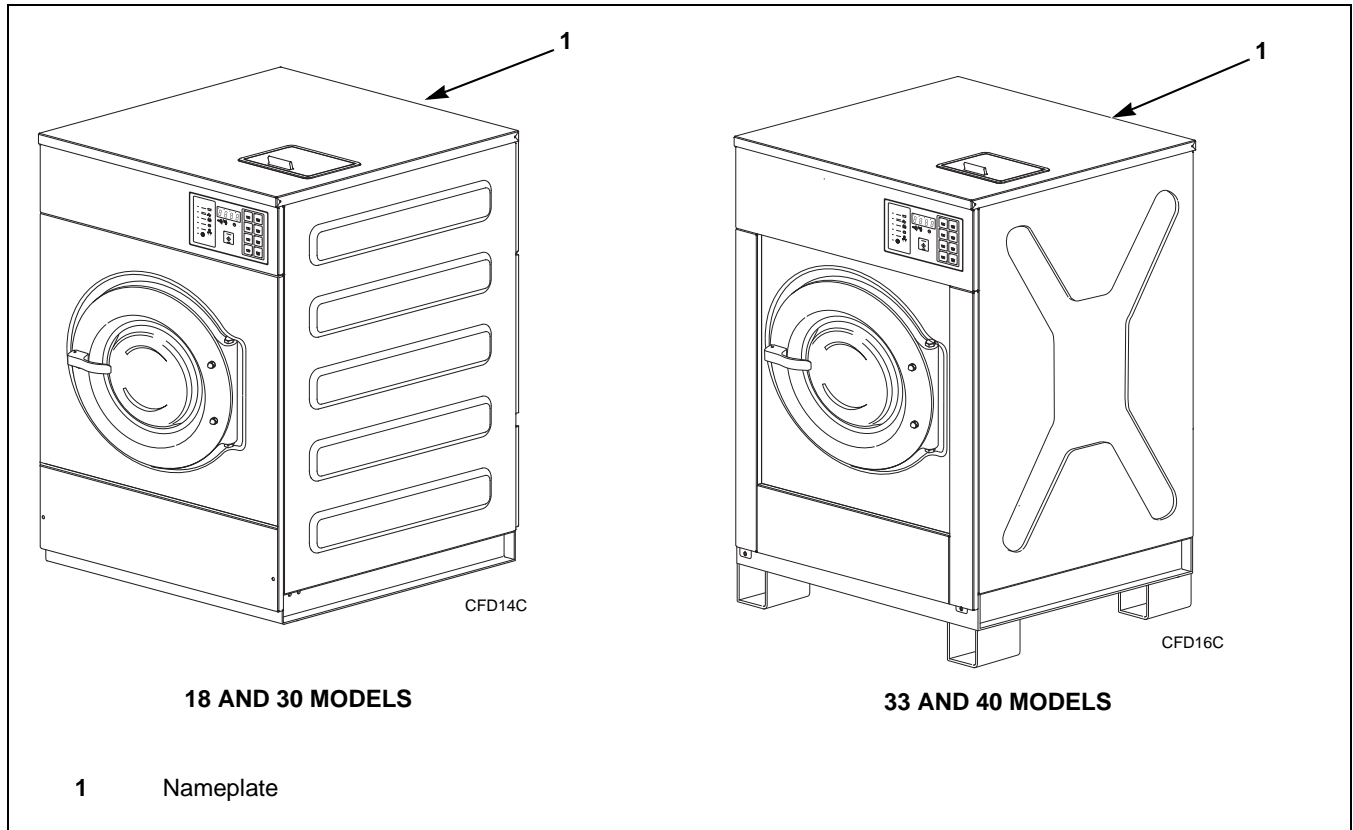

Figure 1

Replacement Parts

If literature or replacement parts are required, contact the source from which the machine was purchased or contact Alliance Laundry Systems at (920) 748-3950 for the name and address of the nearest authorized parts distributor.

Customer Service

For technical assistance, call (920) 748-3121.

Introduction

Model Number Familiarization Guide	
Sample Model Number: NX18BVXM60001	
NX	Model Number Prefix
18	Washer-Extractor Capacity (pounds dry weight of laundry)
B	Type of Electrical Control
V	Washer-Extractor Speed Capability (V = Variable-Speed)
X	Voltage Code
M6	Design Series (M=Domestic, A=International)
0001	Option Identification (varies from machine to machine)

Model No.	NX18BVXM60001		
Serial No.	0000000000		
Voltage	200-240/50-60/1	Amps	6
Required Circuit Breaker	Amps 15		
Hz	50-60	Wire	2/3+PE Phase 1
Max. Load	18 LB	8 KG	Max. Speed 1000 RPM
Elec. Heating	KW	Steam Press.	PSI BAR

EXAMPLE OF NAMEPLATE

CFD22N

Figure 2

Safety Information

Explanation of Safety Messages

Precautionary statements (“DANGER,” “WARNING,” and “CAUTION”), followed by specific instructions, are found in this manual and on machine decals. These precautions are intended for the personal safety of the operator, user, servicer, and those maintaining the machine.

	DANGER
DANGER indicates the presence of a hazard that will cause severe personal injury, death, or substantial property damage if the danger is ignored.	

	WARNING
WARNING indicates the presence of a hazard that can cause severe personal injury, death, or substantial property damage if the warning is ignored.	

	CAUTION
CAUTION indicates the presence of a hazard that will or can cause minor personal injury or property damage if the caution is ignored.	

Additional precautionary statements (“IMPORTANT” and “NOTE”) are followed by specific instructions.

IMPORTANT: The word “IMPORTANT” is used to inform the reader of specific procedures where minor machine damage will occur if the procedure is not followed.

NOTE: The word “NOTE” is used to communicate installation, operation, maintenance or servicing information that is important but not hazard related.

Important Safety Instructions

	WARNING
To reduce the risk of fire, electric shock, serious injury or death to persons when using your washer, follow these basic precautions:	
W023	

1. Read all instructions before using the washer.
2. Refer to the **GROUNDING INSTRUCTIONS** in the **INSTALLATION** manual for the proper grounding of the washer.
3. Do not wash textiles that have been previously cleaned in, washed in, soaked in, or spotted with gasoline, kerosene, waxes, cooking oils, dry-cleaning solvents, or other flammable or explosive substances as they give off vapors that could ignite or explode.
4. Do not add gasoline, dry-cleaning solvents, or other flammable or explosive substances to the wash water. These substances give off vapors that could ignite or explode.
5. Under certain conditions, hydrogen gas may be produced in a hot water system that has not been used for two weeks or more. **HYDROGEN GAS IS EXPLOSIVE.** If the hot water system has not been used for such a period, before using a washing machine or combination washer-dryer, turn on all hot water faucets and let the water flow from each for several minutes. This will release any accumulated hydrogen gas. The gas is flammable, do not smoke or use an open flame during this time.
6. Do not allow children to play on or in the washer. Close supervision of children is necessary when the washer is used near children. This is a safety rule for all appliances.
7. Before the washer is removed from service or discarded, remove the door to the washing compartment.
8. Do not reach into the washer if the wash drum is moving.

Safety Information

9. Do not install or store the washer where it will be exposed to water and/or weather.
10. Do not tamper with the controls.
11. Do not repair or replace any part of the washer, or attempt any servicing unless specifically recommended in the user-maintenance instructions or in published user-repair instructions that the user understands and has the skills to carry out.
12. To reduce the risk of an electric shock or fire, DO NOT use an extension cord or an adapter to connect the washer to the electrical power source.
13. Use washer only for its intended purpose, washing textiles.
14. Never wash machine parts or automotive parts in the machine. This could result in serious damage to the basket.
15. ALWAYS disconnect the washer from electrical supply before attempting any service. Disconnect the power cord by grasping the plug, not the cord.
16. Install the washer according to the INSTALLATION INSTRUCTIONS. All connections for water, drain, electrical power and grounding must comply with local codes and be made by licensed personnel when required.
17. To reduce the risk of fire, textiles which have traces of any flammable substances such as vegetable oil, cooking oil, machine oil, flammable chemicals, thinner, etc., or anything containing wax or chemicals such as in mops and cleaning cloths, must not be put into the washer. These flammable substances may cause the fabric to catch on fire by itself.
18. Do not use fabric softeners or products to eliminate static unless recommended by the manufacturer of the fabric softener or product.
19. Keep washer in good condition. Bumping or dropping the washer can damage safety features. If this occurs, have washer checked by a qualified service person.
20. If the supply cord is damaged, it must be replaced by a special cord or assembly available from the manufacturer or its service agent.
21. Be sure water connections have a shut-off valve and that fill hose connections are tight. CLOSE the shut-off valves at the end of each wash day.
22. Loading door MUST BE CLOSED any time the washer is to fill, tumble or spin. DO NOT bypass the loading door switch by permitting the washer to operate with the loading door open.
23. Always read and follow manufacturer's instructions on packages of laundry and cleaning aids. Heed all warnings or precautions. To reduce the risk of poisoning or chemical burns, keep them out of the reach of children at all times (preferably in a locked cabinet).
24. Always follow the fabric care instructions supplied by the textile manufacturer.
25. Never operate the washer with any guards and/or panels removed.
26. DO NOT operate the washer with missing or broken parts.
27. DO NOT bypass any safety devices.
28. Failure to install, maintain, and/or operate this washer according to the manufacturer's instructions may result in conditions which can produce bodily injury and/or property damage.

NOTE: The WARNINGS and IMPORTANT SAFETY INSTRUCTIONS appearing in this manual are not meant to cover all possible conditions and situations that may occur. Common sense, caution and care must be exercised when installing, maintaining, or operating the washer.

Any problems or conditions not understood should be reported to the dealer, distributor, service agent or the manufacturer.

	WARNING
<p>This machine must be installed, adjusted, and serviced by qualified electrical maintenance personnel familiar with the construction and operation of this type of machinery. They must also be familiar with the potential hazards involved. Failure to observe this warning may result in personal injury and/or equipment damage, and may void the warranty.</p>	
SW004	

IMPORTANT: Ensure that the recommended clearances for inspection and maintenance are provided. Never allow the inspection and maintenance space to be blocked.

	WARNING
<p>Install the machine on a level floor of sufficient strength. Failure to do so may result in conditions which can produce serious injury, death and/or property damage.</p>	
W703	

	CAUTION
<p>Be careful around the open door, particularly when loading from a level below the door. Impact with door edges can cause personal injury.</p>	
SW025	

	WARNING
<p>Never touch internal or external steam pipes, connections, or components. These surfaces can be extremely hot and will cause severe burns. The steam must be turned off and the pipe, connections, and components allowed to cool before the pipe can be touched.</p>	
SW014	

Safety Decals

Safety decals appear at crucial locations on the machine. Failure to maintain legible safety decals could result in injury to the operator or service technician.

To provide personal safety and keep the machine in proper working order, follow all maintenance and safety procedures presented in this manual. If questions regarding safety arise, contact the manufacturer immediately.

Use manufacturer-authorized spare parts to avoid safety hazards.

Safety Information

Operator Safety

	WARNING
NEVER insert hands or objects into basket until it has completely stopped. Doing so could result in serious injury.	
<small>SW012</small>	

To ensure the safety of machine operators, the following maintenance checks must be performed daily:

1. Prior to operating the machine, verify that all warning signs are present and legible. Missing or illegible signs must be replaced immediately. Make certain that spares are available.
2. Check door interlock before starting operation of the machine:
 - a. Attempt to start the machine with the door open. The machine should not start with the door open.
 - b. Close the door without locking it and attempt to start the machine. The machine should not start with the door unlocked.
 - c. Close and lock the door and start a cycle. Attempt to open the door while the cycle is in progress. The door should not open.If the door lock and interlock are not functioning properly, call a service technician.
3. Do not attempt to operate the machine if any of the following conditions are present:
 - a. The door does not remain securely locked during the entire cycle.
 - b. Excessively high water level is evident.
 - c. Machine is not connected to a properly grounded circuit.

Do not bypass any safety devices in the machine.

	WARNING
Never operate the machine with a bypassed or disconnected balance system. Operating the machine with severe out-of-balance loads could result in personal injury and serious equipment damage.	
<small>SW039</small>	

Specifications and Dimensions

General Specifications				
Model	18	30	33	40
Overall Dimensions				
Overall width	26 in. (660 mm)	30.7 in. (780 mm)	30.7 in. (780 mm)	30.7 in. (780 mm)
Overall height	40.9 in. (1038 mm)	47.3 in. (1202 mm)	54.15 in. (1376 mm)	54.15 in. (1376 mm)
Overall depth	29.1 in. (739 mm)	33.1 in. (842 mm)	33.07 in. (840 mm)	37.01 in. (940 mm)
Weight and Shipping Information				
Net weight	465.2 lb. (211 kg)	716.5 lb. (325 kg)	811.30 lb. (368 kg)	862.01 lb. (391 kg)
Shipping weight	513.7 lb. (233 kg)	782.6 lb. (355 kg)	844.37 lb. (383 kg)	921.53 lb. (418 kg)
Shipping volume	22.5 ft ³ (0.8 m ³)	34.7 ft ³ (1.3 m ³)	42.83 ft ³ (1.21 m ³)	45.98 ft ³ (1.3 m ³)
Wash Cylinder Information				
Cylinder diameter	20.9 in. (530 mm)	25.6 in. (650 mm)	26.77 in. (680 mm)	26.77 in. (680 mm)
Cylinder depth	13 in. (330 mm)	15.76 in. (400 mm)	15.75 in. (400 mm)	19.69 in. (500 mm)
Cylinder volume	2.7 ft ³ (76 l)	4.66 ft ³ (132 l)	5.12 ft ³ (145 l)	6.39 ft ³ (181 l)
Perforation size	0.12 in. (3 mm)	0.12 in. (3 mm)	0.12 in. (3 mm)	0.12 in. (3 mm)
Door Opening Information				
Door opening size	11.8 in. (300 mm)	11.8 in. (300 mm)	15.75 in. (400 mm)	15.75 in. (400 mm)
Height of door bottom above floor	11 in. (280 mm)	15 in. (381 mm)	18.58 in. (472 mm)	18.58 in. (472 mm)

Specifications and Dimensions

General Specifications				
Model	18	30	33	40
Drive Train Information				
Number of motors in drive train	1	1	1	1
Drive motor power	1 HP (0.75 kW)	2 HP (1.5 kW)	2.95 HP (2.2 kW)	2.95 HP (2.2 kW)
Cylinder Speeds				
Wash/reverse speed	10-50 RPM	10-50 RPM	10-50 RPM	10-50 RPM
Distribution/drain speed	85 RPM	85 RPM	85 RPM	85 RPM
Extract speed	250-1000 RPM	250-1000 RPM	250-1000 RPM	250-1000 RPM
Centrifugal Force Data				
Wash/reverse centrifugal force	0.03-0.74 Gs	0.04-0.91 Gs	0.37-0.94 Gs	0.37-0.94 Gs
Extract centrifugal force	19-296 Gs	23-363 Gs	24-377 Gs	24-377 Gs
Balance Detection				
Vibration safety switch installed	Standard	Standard	Standard	Standard
Electrical Heating (International Models Only)				
Total electrical heating capacity	9 kW	18 kW	18 kW	18 kW
Electrical heating elements	3	6	6	6
Electrical heat element size	3 kW	3 kW	3 kW	3 kW

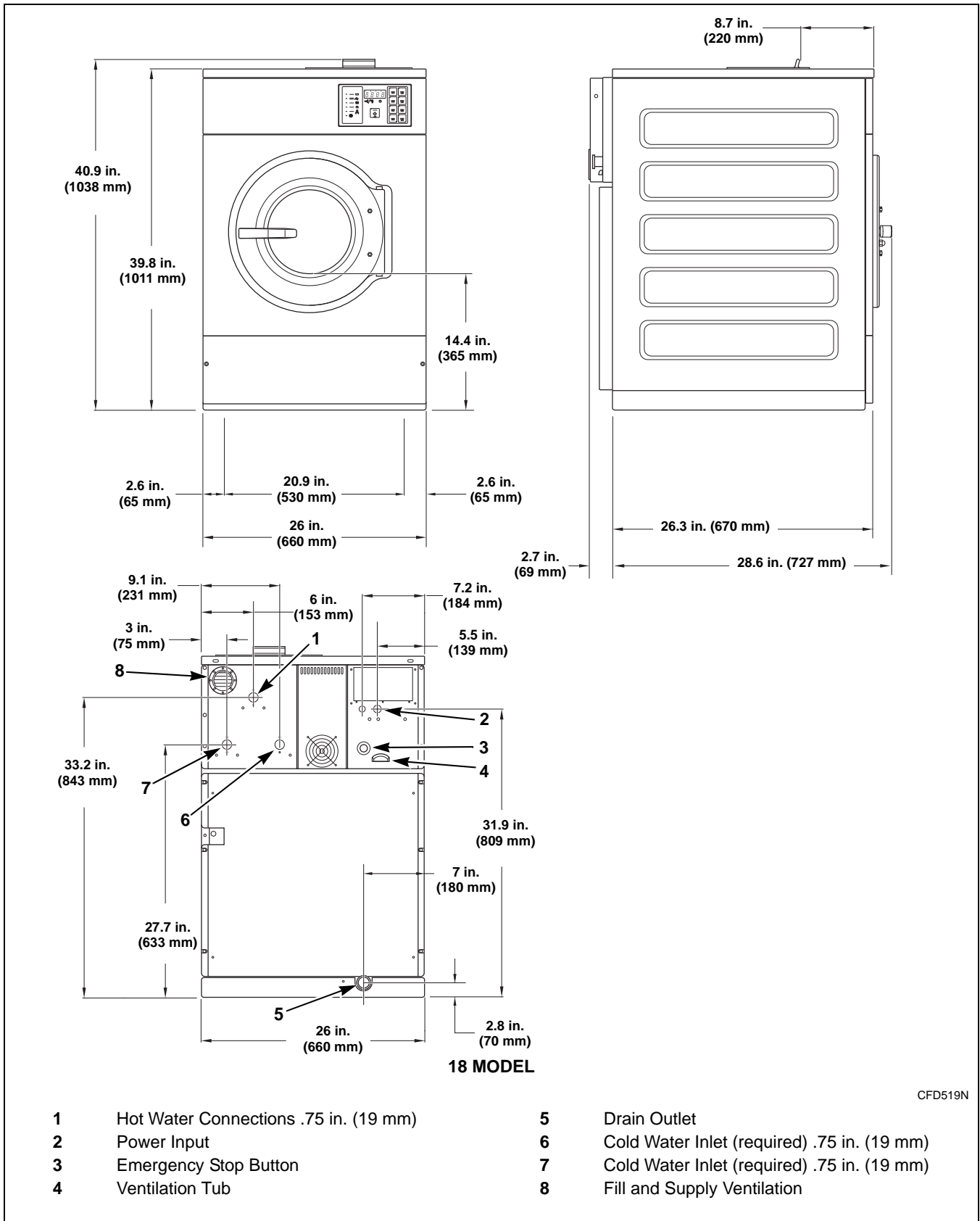
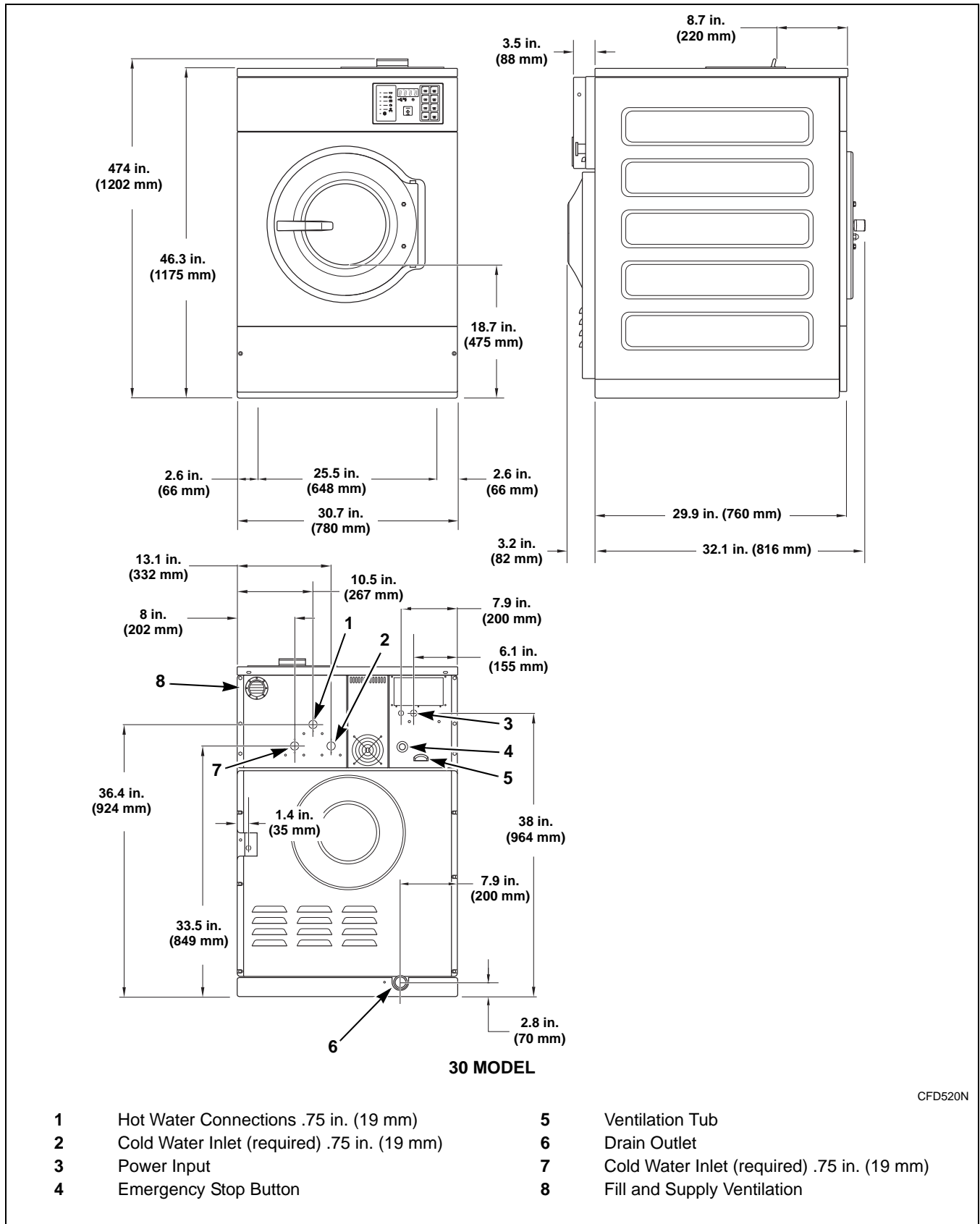

Figure 3

Specifications and Dimensions



CFD520N

Figure 4

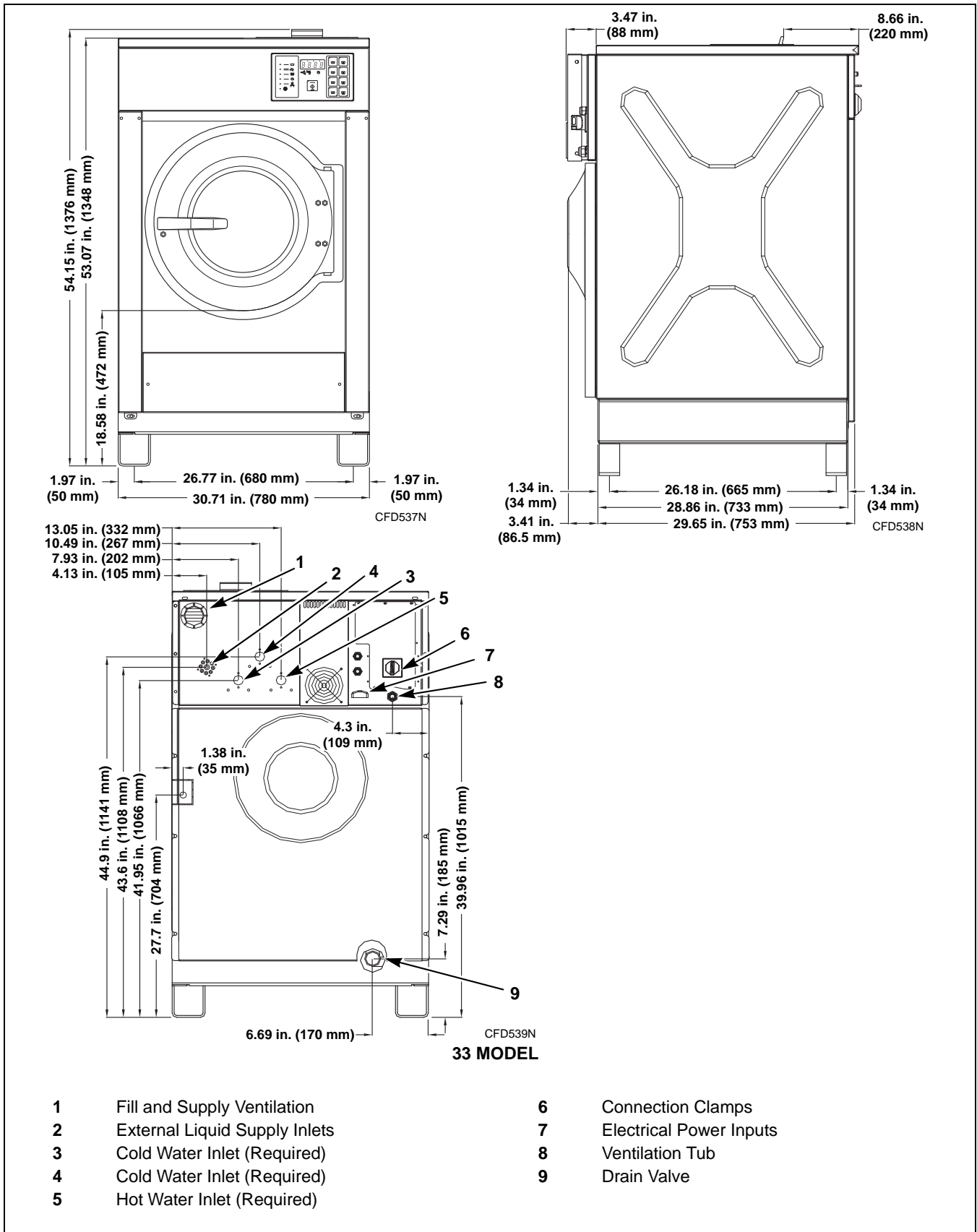

Figure 5

Specifications and Dimensions

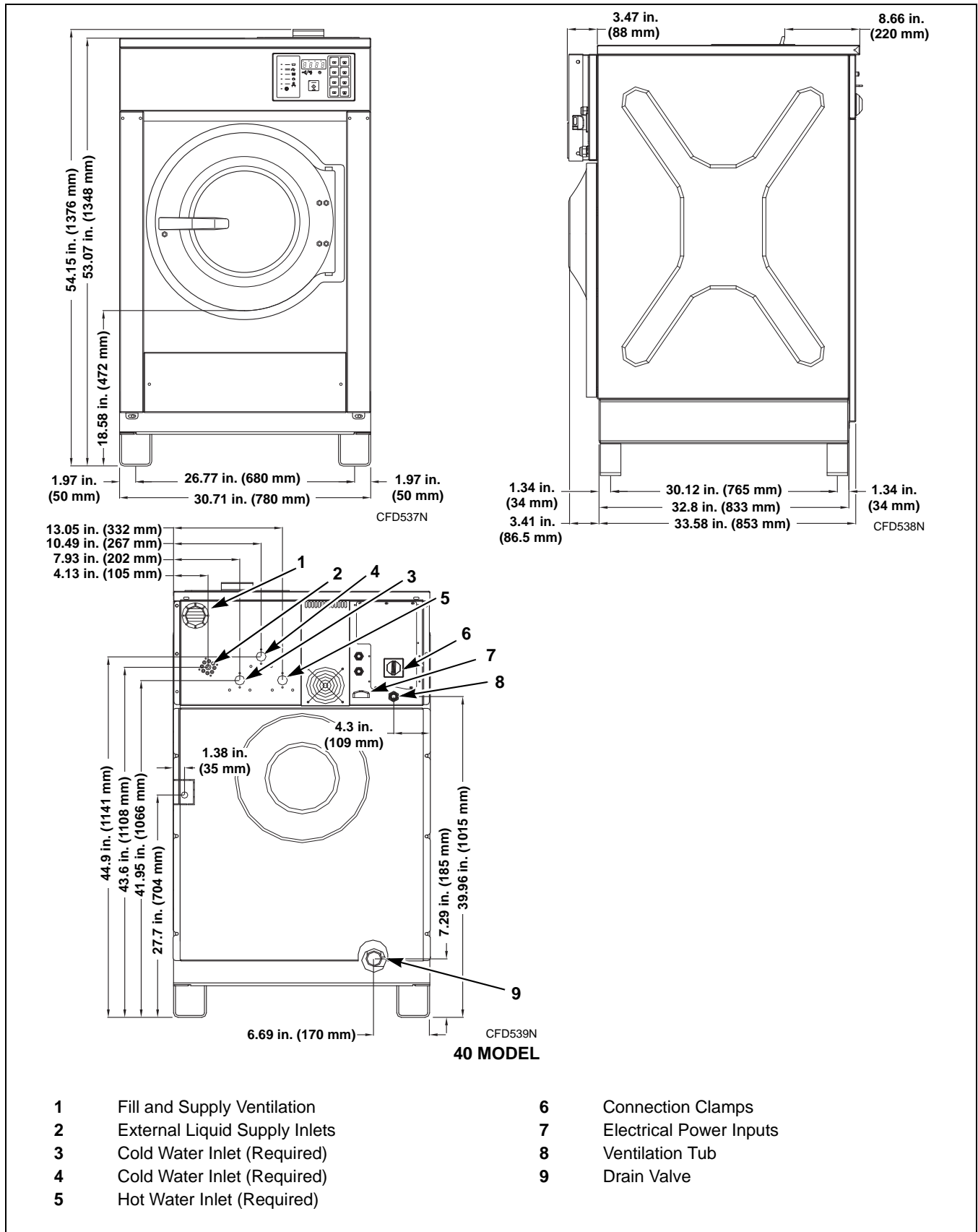

Figure 6

Installation

Dimensional Clearances

Table 1 shows recommended minimum clearances on all sides of the washer-extractor.

Recommended Minimum Clearances				
Model	18	30	33	40
Minimum rear clearance	24 in. (600 mm)	24 in. (600 mm)	24 in. (600 mm)	24 in. (600 mm)
Minimum clearance between machine and wall	6 in. (150 mm)	6 in. (150 mm)	6 in. (150 mm)	6 in. (150 mm)
Minimum clearance between machines (side)	1 in. (25.4 mm)	1 in. (25.4 mm)	1.2 in. (33 mm)	1.2 in. (33 mm)
Minimum front clearance (door swing)	16.5 in. (419 mm)	16.5 in. (419 mm)	21 in. (533 mm)	21 in. (533 mm)

Table 1

Machine Foundation

Thoroughness of detail must be stressed with all foundation work to ensure a stable unit installation, eliminating possibilities of excessive vibration during extract.

	CAUTION
<p>Ensure that the machine is installed on a level floor of sufficient strength and that the recommended clearances for inspection and maintenance are provided. Never allow the inspection and maintenance space to be blocked.</p>	
<small>W488</small>	

The washer-extractor must be placed on a smooth level surface so that the entire base of the machine is supported and rests on the mounting surface.

The standard installation does not require anchoring unless mandated by state or local codes.

Kinetic energy of the cylinder and dynamic loads on the floor or foundation are shown in Table 2.

Table 2 can be used as a reference when designing floors and foundations.

Floor Load Data				
Model	18	30	33	40
Kinetic energy of the cylinder	1386 N/m	2592 N/m	2736 N/m	4105 N/m
Dynamic bottom load	700 N/16 Hz	1000 N/16 Hz	1200 N/16 Hz	1200 N/16 Hz

Table 2

Mechanical Installation

Frame Dimensions and Mounting Bolt Location

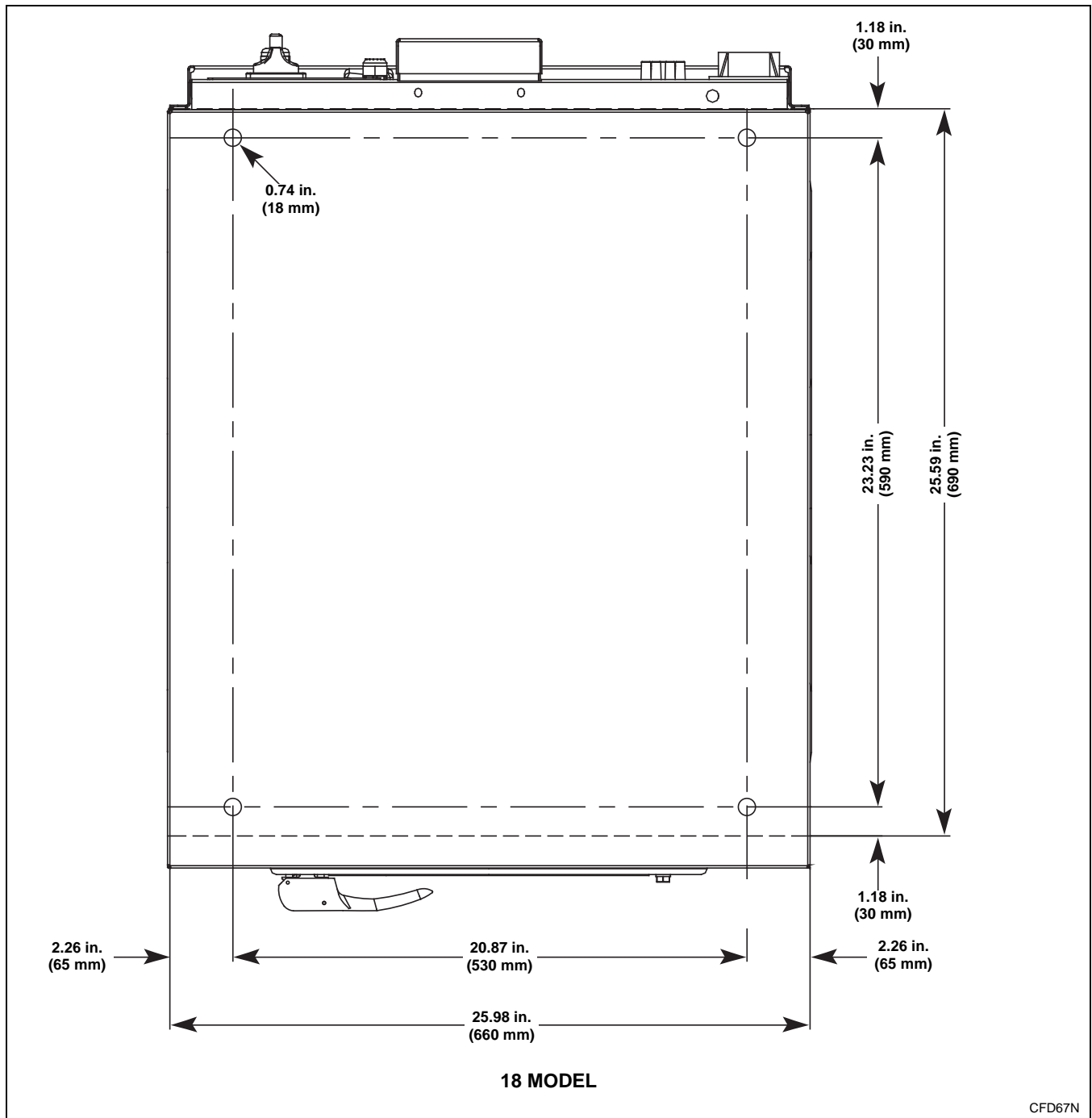

Figure 7

IMPORTANT: Drawing is not to scale.

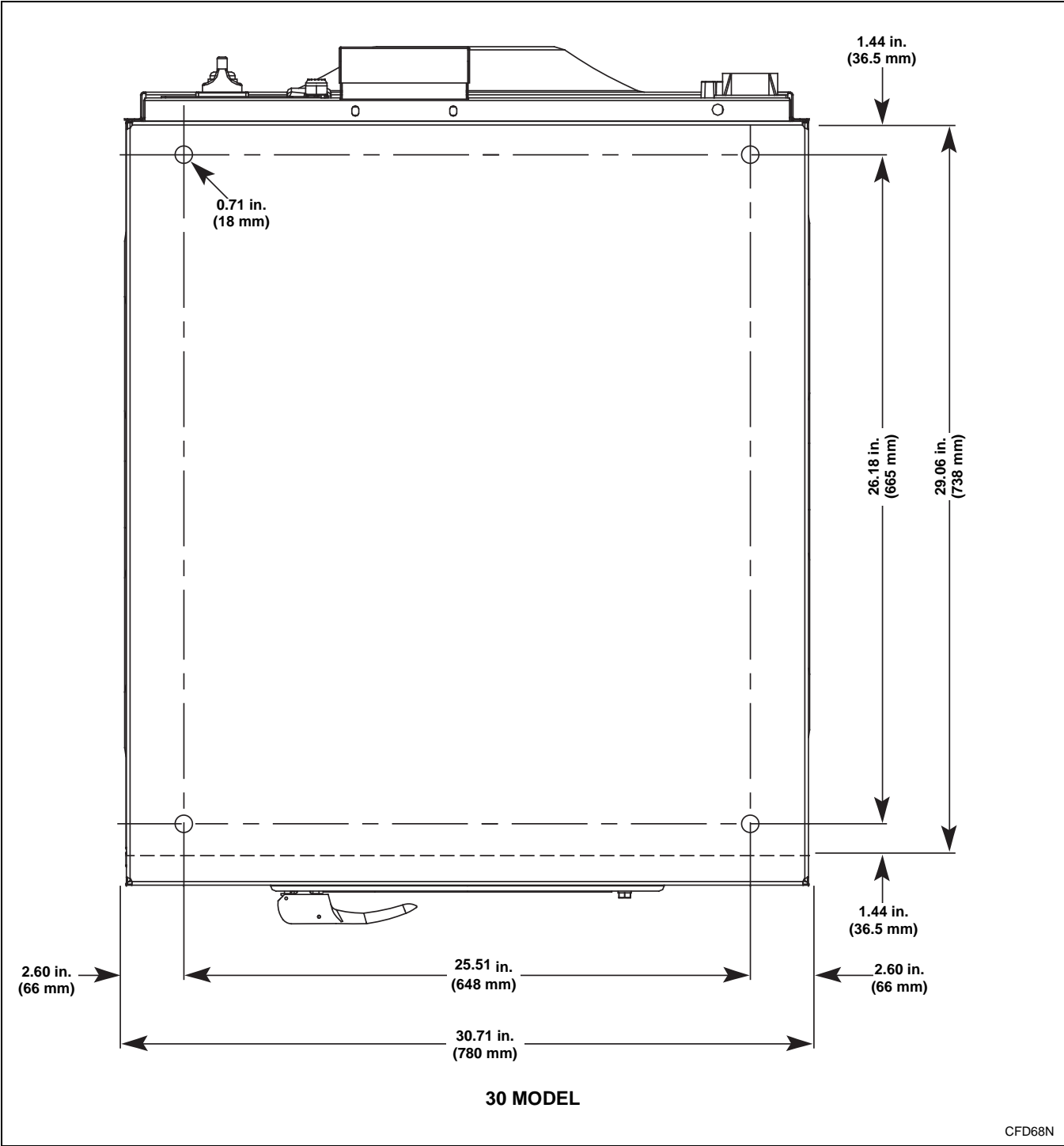

Figure 8

IMPORTANT: Drawing is not to scale.

Installation

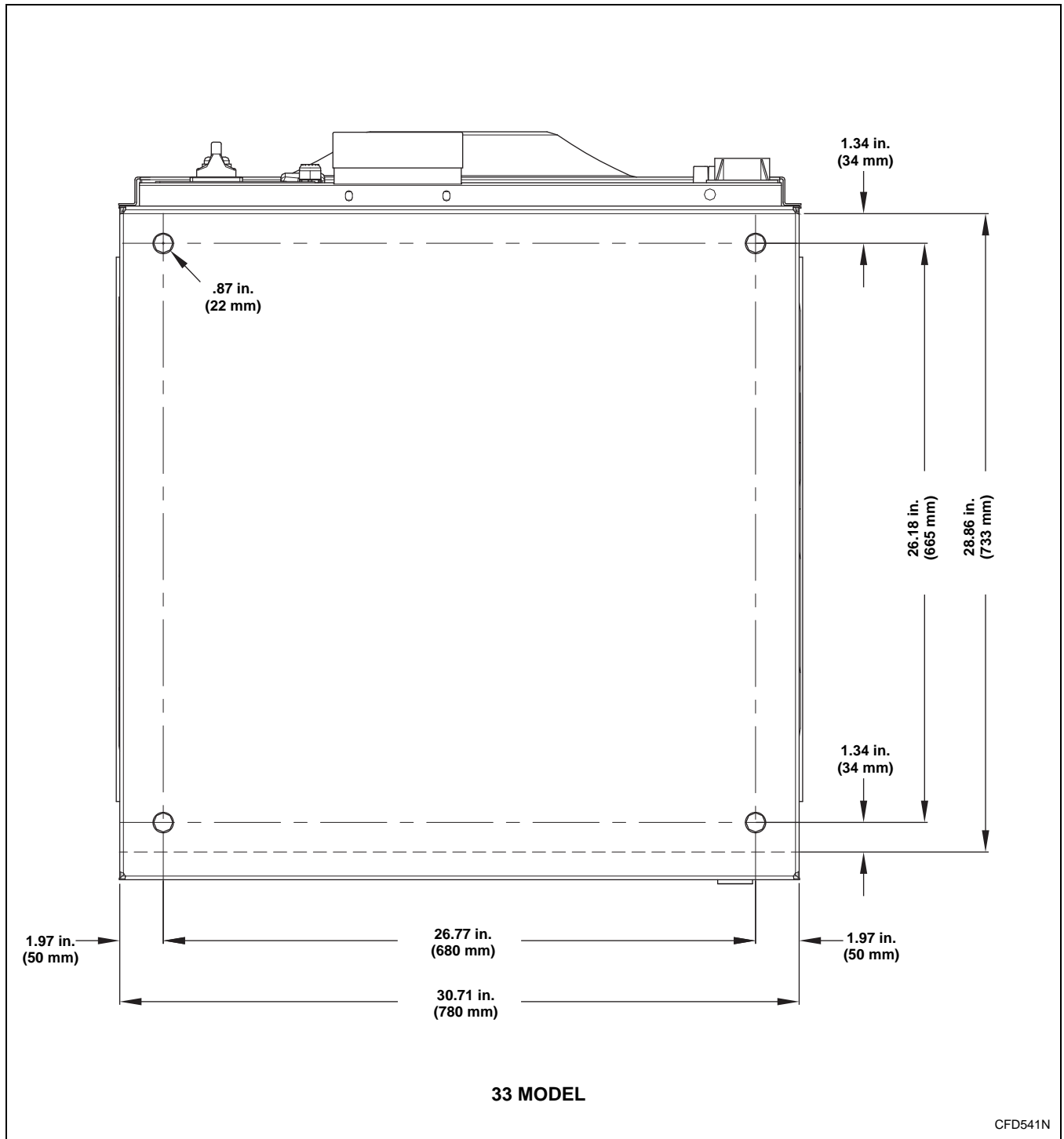

Figure 9

IMPORTANT: Drawing is not to scale.

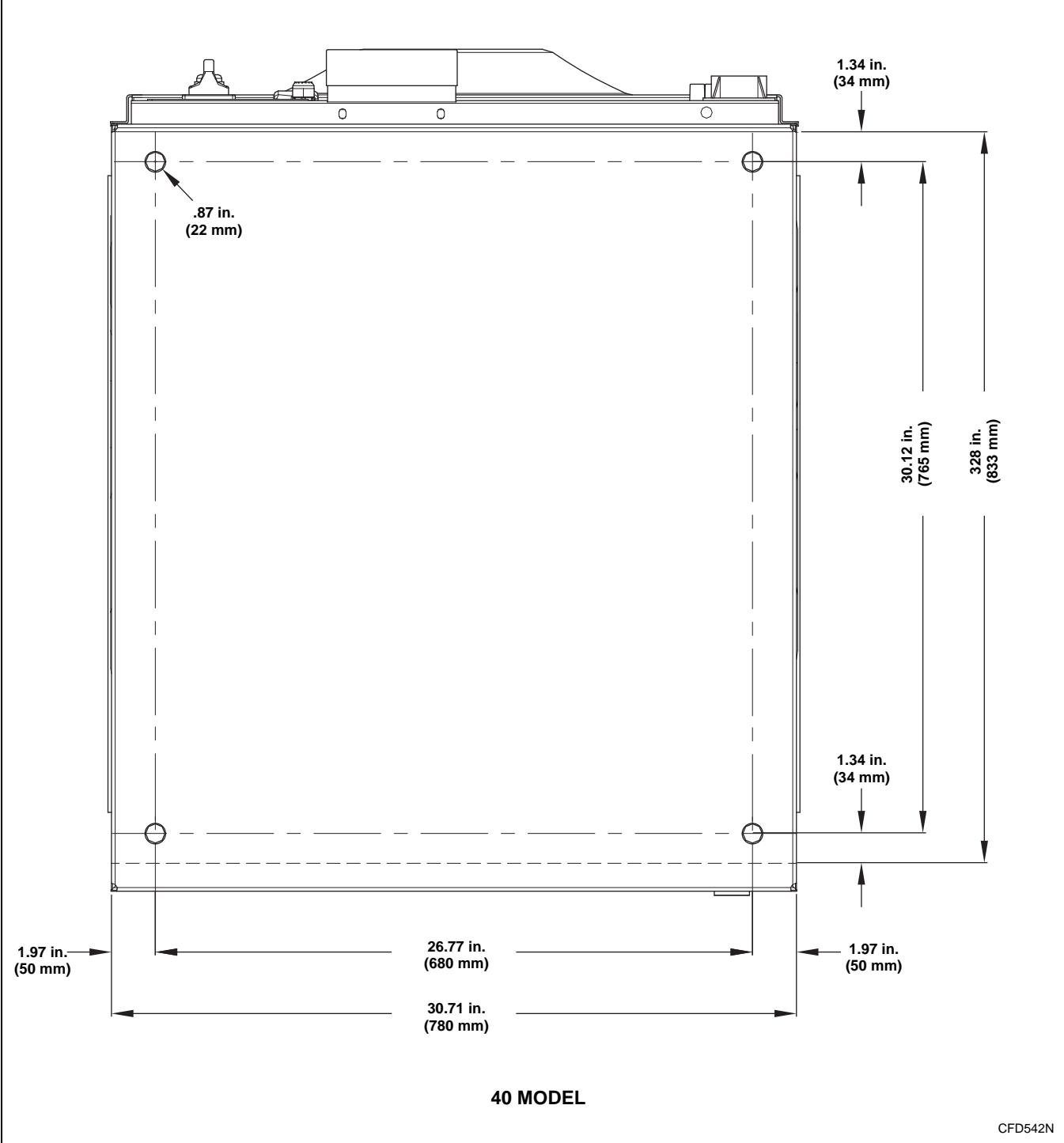

Figure 10

IMPORTANT: Drawing is not to scale.

Installation

Mounting Bolt Installation (If Required)

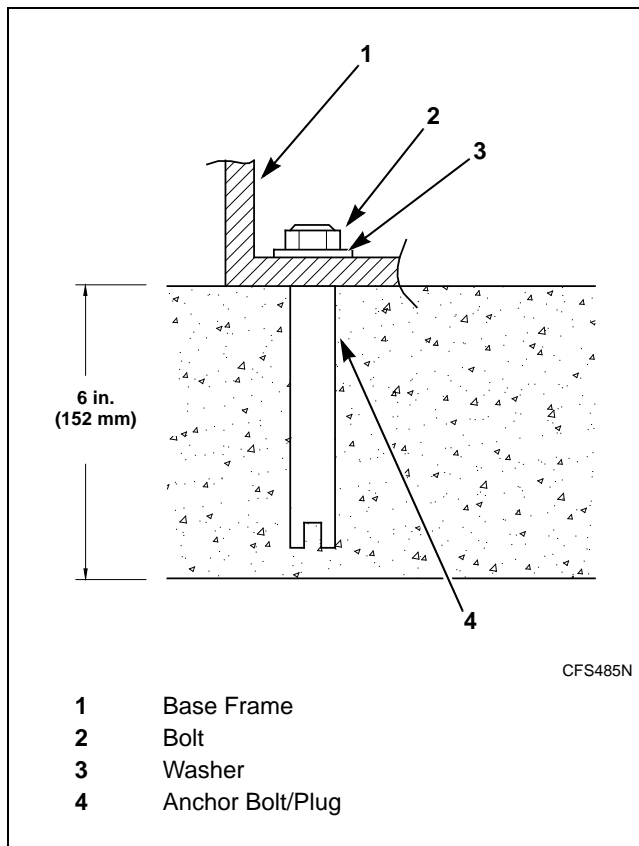

Figure 11

After the concrete has cured and the anchors are installed, proceed as follows:

1. Place the washer-extractor adjacent to the foundation. Do not attempt to move it by pushing on the sides. Always insert a pry bar or other device under the bottom of the frame of the washer-extractor to move it.
2. Place the washer-extractor carefully over the anchors.
3. Put bolts through the machine in the anchors and fasten them. For 18 and 30 models, the diameter of the bolt must be minimum 1/2-13 or 12 mm. For 33 and 40 models, the diameter of the bolt must be minimum 5/8-11 or 16 mm.
4. To level machine, fill the spaces between the machine base and floor with machinery grout. Grout completely under all frame members. Remove front and rear panels to gain access to all frame members. Force grout under the machine base until all voids are filled.
5. Remove the spacers carefully, allowing the machine to settle into the wet grout.
6. Position washers and locknuts on machinery anchor bolts and fingertighten to machine base.
7. After the grout is completely dry, tighten the locknuts by even increments – one after the other – until all are tightened evenly and the machine is fastened securely to the floor.

Removing the Transport Block

	WARNING
The machine must never be activated before removing the transport block.	
W618	

To prevent damage during transportation, machine has been equipped with a transport block. To remove, proceed as follows:

1. Place machine on level ground.
2. Remove service panels and back panel.
3. For 18 and 30 models, at rear of machine, lift at bottom of motor and remove transport block if present. Refer to *Figure 12*.

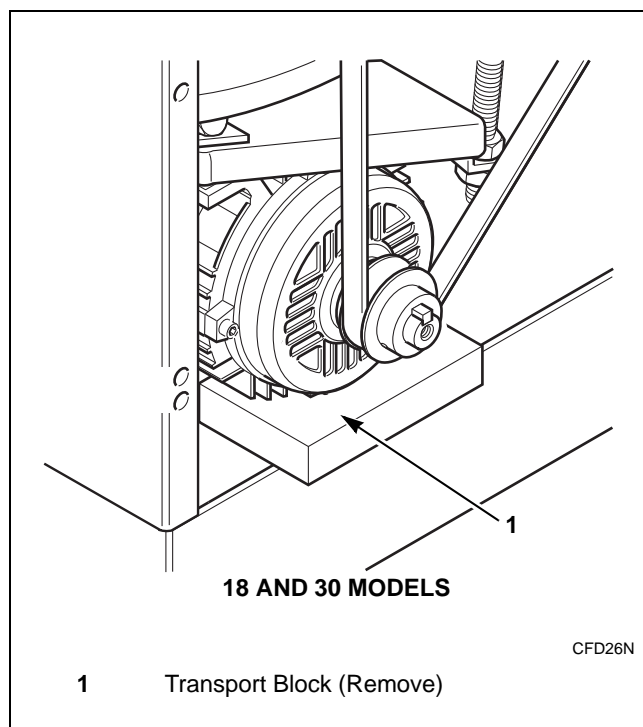

Figure 12

IMPORTANT: Do NOT lift motor by the pulley.

4. For 18 and 30 models, remove the panel braces. Refer to *Figure 13*.

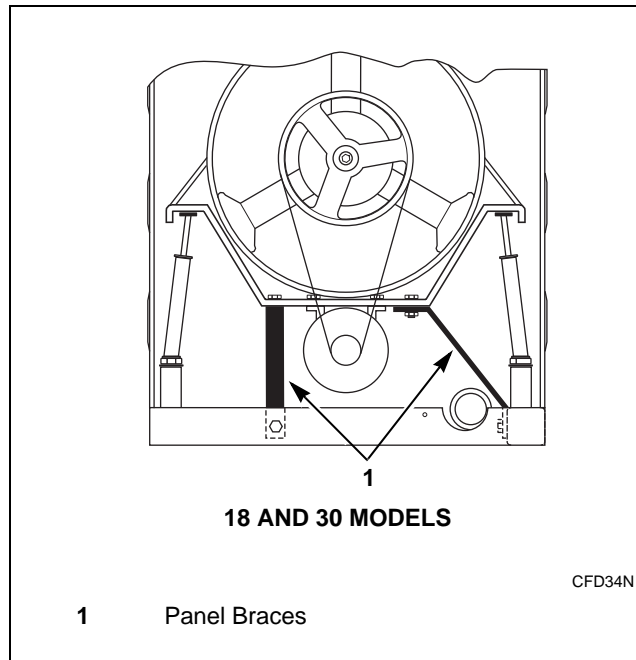

Figure 13

5. For 33 and 40 models, remove the transport brackets. Refer to *Figure 14*.

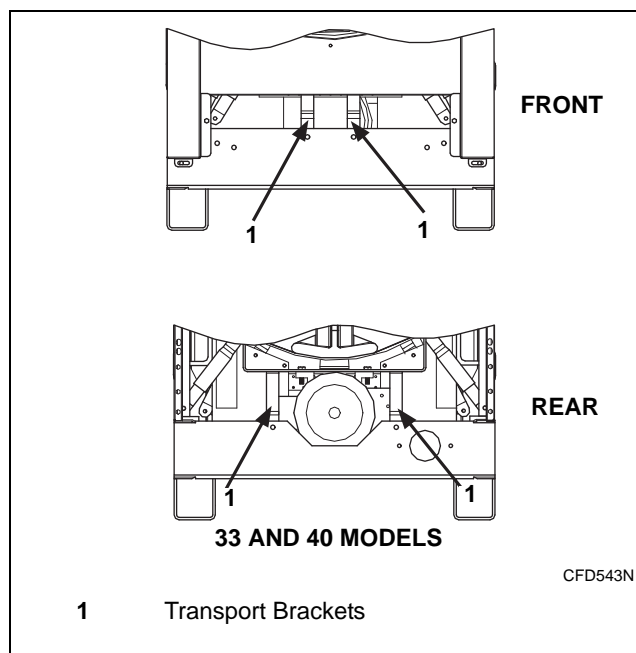

Figure 14

6. Replace all panels removed.

Installation

Drain Connection

A drain system of adequate capacity is essential to washer-extractor performance.

Ideally, the water should empty through a vented pipe directly into a sump or floor drain.

Figure 15 shows drain line and drain trough configurations.

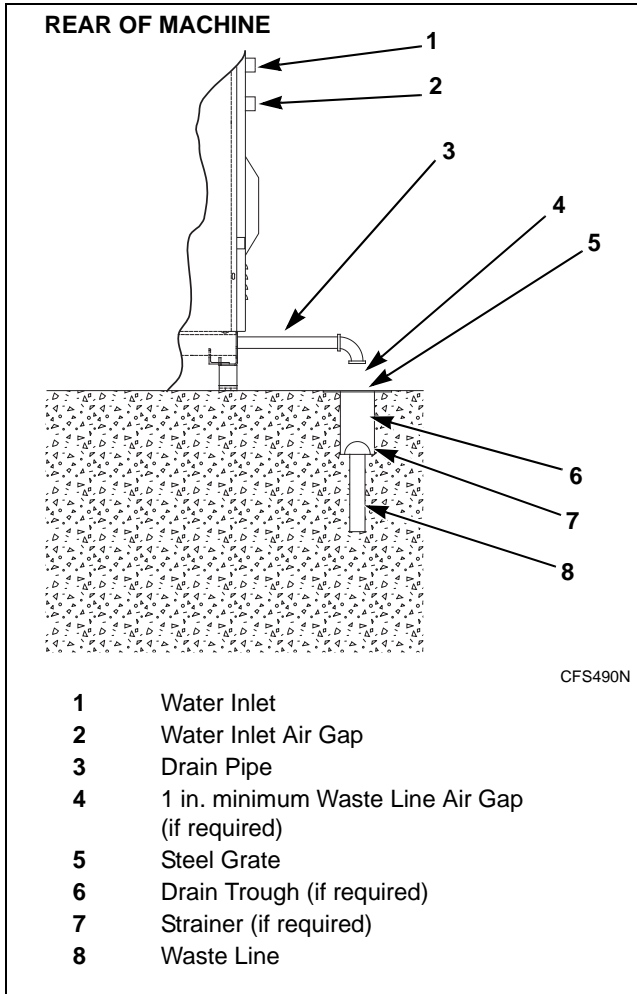

Figure 15

A flexible connection must be made to a vented or air gap drain system to prevent an air lock and to prevent siphoning. If proper drain size is not available or practical, a surge tank is required. A surge tank in conjunction with a sump pump should be used when gravity drainage is not possible, such as in below-ground-level installations.

Before any deviation from specified installation procedures is attempted, the customer or installer should contact the distributor.

Increasing the drain hose length, installing elbows, or causing bends will decrease, impairing washer-extractor performance.

Refer to Table 3 for capacity-specific drain information.

Installation of additional washer-extractors will require proportionately larger drain connections. Refer to Table 4.

Drain Information				
Model	18	30	33	40
Drain connection size, ID	2 in. (51 mm)	2 in. (51 mm)	2 in. (50 mm)	2 in. (50 mm)
Number of drain outlets	1	1	1	1
Drain flow capacity	20 gal/min (76 l/min)	20 gal/min (76 l/min)	21.13 gal/min (80 l/min)	21.13 gal/min (80 l/min)
Recommended drain pit size	1.8 ft ³ (51 l)	2.5 ft ³ (70.3 l)	5.1 ft ³ (145 l)	6.4 ft ³ (181 l)

Table 3

Drain Line Sizing Minimum Drain ID							
Model	Number of Machines						
	1	2	3	4	5	6	7
18	2 in. (51 mm)	3 in. (76.2 mm)	3 in. (76 mm)	4 in. (102 mm)	4 in. (102 mm)	5 in. (124 mm)	5.5 in. (140 mm)
30	2 in. (51 mm)	3 in. (76.2 mm)	3.5 in. (88 mm)	4 in. (102 mm)	4.5 in. (114 mm)	5 in. (124 mm)	5.5 in. (140 mm)
33	2 in. (51 mm)	3 in. (76.2 mm)	3.5 in. (88 mm)	4 in. (102 mm)	4.5 in. (114 mm)	5 in. (124 mm)	5.5 in. (140 mm)
40	2 in. (51 mm)	3 in. (76.2 mm)	3.5 in. (88 mm)	4 in. (102 mm)	4.5 in. (114 mm)	5 in. (124 mm)	5.5 in. (140 mm)

Table 4

Water Connection

	WARNING
<p>To avoid personal injury, recommended inlet water temperature should be no higher than 125° Fahrenheit (51° Celsius).</p> <p style="text-align: right; font-size: small;">W709</p>	

The models are delivered with three hoses with 3/4 inch hose connectors. These hoses fit the water inlet valves of the machine and the main water inlet taps. To ensure the optimal functioning of the water inlet valves, the water pressure on the inlet should be between 30-85 psi (2-5.86 bar). If the pressure is too low, the cycle time will increase considerably.

Connections should be supplied by a hot and a cold water line per national and local codes.

To connect water service to machine with rubber hoses, use the following procedure:

1. Before installing hoses, flush the water system for at least two minutes.
2. Check filters in the washer-extractor's inlet for proper fit and cleanliness before connecting.
3. Hang the hoses in a large loop, do not allow them to kink.

If additional hose length is needed use flexible hoses.

Pressure of 30-85 psi (2-5.86 bar) provides best performance. Although the washer-extractor will function at lower pressures, increased fill times will occur with some loss of supply flushing.

Suitable air cushions should be installed in supply lines to prevent "hammering."

Water Supply Information				
Model	18	30	33	40
Water inlet connection size	0.75 in. (19 mm)	0.75 in. (19 mm)	0.75 in. (19 mm)	0.75 in. (19 mm)
Number of water inlets (standard)	3	3	3	3
Recommended pressure	30-85 psi (2-5.86 bar)	30-85 psi (2-5.86 bar)	30-85 psi (2-5.7 bar)	30-85 psi (2-5.7 bar)
Inlet flow capacity	5.3 gal/ min (20 l/min)	5.3 gal/ min (20 l/min)	5.3 gal/ min (20 l/min)	5.3 gal/ min (20 l/min)

Table 5

Installation

Electrical Installation

IMPORTANT: Electrical ratings are subject to change. Refer to serial decal for electrical ratings information specific to your machine.

IMPORTANT: Alliance Laundry Systems warranty does not cover compounds that fail as a result of improper input voltage.

	WARNING
Hazardous Voltage. Can cause shock, burn or cause death. Allow machine power to remain off for two minutes prior to working in and around AC inverter drive.	
W359	

	WARNING
Hazardous Voltage. Can cause shock, burn or death. Verify that a ground wire from a proven earth ground is connected to the lug near the input power block on this machine.	
W360	

The AC inverter drive requires a clean power supply free from voltage spikes and surges. A voltage monitor should be used to check incoming power. The customer's local power company may provide such a monitor.

If input voltage measures above 240V for a 220V drive or above 415V for a 400V drive, ask the power company to lower the voltage. As an alternative, a step-down transformer kit is available from the distributor.

The AC drive provides overload protection for the drive motor. However, a separate single or three phase circuit breaker must be installed for complete electrical overload protection. This prevents damage to the motor by disconnecting all legs if one should be lost accidentally. Check the data plate on the back of the washer-extractor or consult *Table 6* for circuit breaker requirements.

	DANGER
Do not use a phase adder on any variable-speed machine.	
W490	

The washer-extractor should be connected to an individual branch circuit not shared with lighting or other equipment.

The connection should be shielded in a liquid tight or approved flexible conduit with proper conductors of correct size installed in accordance with the National Electric Code or other applicable codes. The connection must be made by a qualified electrician using the wiring diagram provided with the washer-extractor, or according to accepted European standards for CE-approved equipment.

Use wire sizes indicated in *Table 6* for runs up to 50 feet.

Use next larger size for runs of 50 to 100 feet. Use two sizes larger for runs greater than 100 feet.

For personal safety and proper operation, the washer-extractor must be grounded in accordance with state and local codes. If such codes are not available, grounding must conform with the National Electric Code, article 250-95. The ground connection must be made to a proven earth ground, not to conduit or water pipes.

Electrical Connection

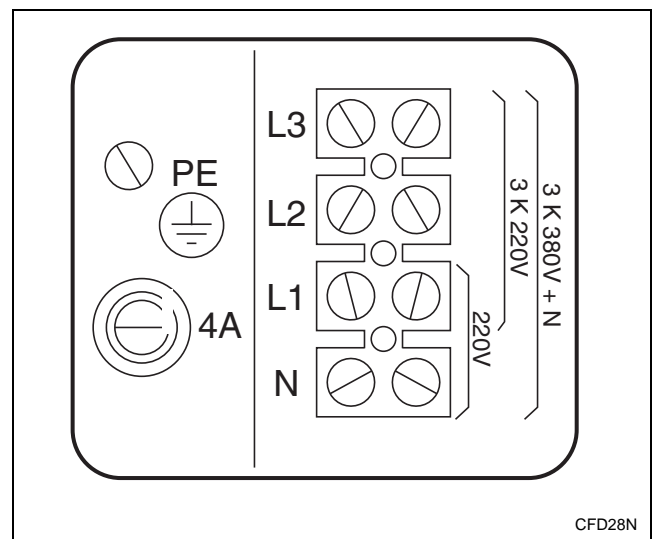

Figure 16

Remove the cover plate at the back of the machine.

Connect the power cable to the connectors using copper conductors only.

Machine without Electric Heating

Connect 200-240V single phase (1AC) to the connectors "N" and "L1". The green/yellow grounding clamp has to be the grounding wire "PE".

Machine with Electric Heating

380-415V 3AC + N

200-240V 3AC

200-240V 3 phase (3AC) should be connected to the connectors “L1, L2, L3”. Refer to *Figure 16*.

The green/yellow grounding clamp has to be connected to the grounding wire “PE”.

380-415V 3 phase (3AC + N) has to be connected to the connectors “L1, L2, L3”, the blue neutral to the “N” connector. Refer to *Figure 16*.

The green/yellow grounding clamp has to be connected to the grounding wire “PE”.

Electrical Specifications													
Voltage Designation						Standard				Electric Heat			
Model	Code	Voltage	Cycle	Phase	Wire	Full Load Amps	Circuit Breaker	AWG/mm ²	KW	Full Load Amps	Circuit Breaker	AWG/mm ²	KW
18	P	380-415	50/60	3	3+N+PE	Not available				21	30	10/6.0	9
	Q	200-240	50/60	3	3+PE	Not available				27	30	10/6.0	9
	X	200-240	50/60	1/3	2/3+PE	12	15	14/2.5	0.75	Not available			
30	P	380-415	50/60	3	3+N+PE	Not available				36	40	8/10.0	18
	Q	200-240	50/60	3	3+PE	Not available				49	60	6/16.0	18
	X	200-240	50/60	1/3	2/3+PE	18	20	12/4.0	1.5	Not available			
33	P	380-415	50/60	3	3+N+PE	18	20	12/4.0	1.5	44	50	8/10.0	18
	Q	200-240	50/60	3	3+PE	18	20	12/4.0	1.5	63	70	4/25.0	18
	X	200-240	50/60	1/3	2/3+PE	18	20	12/4.0	1.5	Not available			
40	P	380-415	50/60	3	3+N+PE	18	20	12/4.0	1.5	44	50	8/10.0	18
	Q	200-240	50/60	3	3+PE	18	20	12/4.0	1.5	63	70	4/25.0	18
	X	200-240	50/60	1/3	2/3+PE	18	20	12/4.0	1.5	Not available			

Table 6

After electrical installation is complete, run the machine through a test cycle and check for a clockwise basket rotation during the extract step. If rotation is not clockwise, disconnect the power from the machine and have a qualified electrician reverse any 2 motor leads at the AC drive terminal block.

Installation

Out-of-Balance Switch

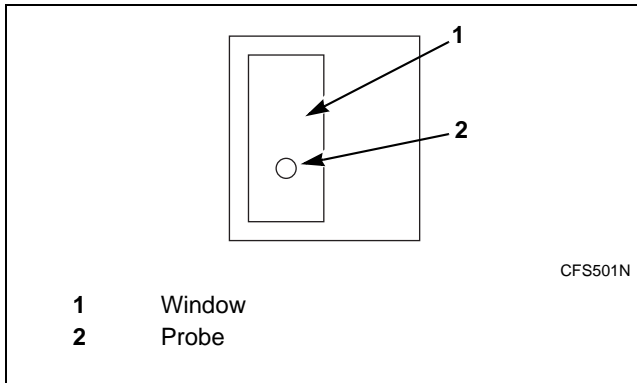

Figure 17

The out-of-balance switch is mounted on the upper right side on the back of the control panel. There is a window around the probe of the switch that is mounted on the movable part of the machine.

When the machine goes out of balance by overloading or uneven distribution of the linen, the out-of-balance switch will interrupt this action to prevent damage to the machine.

IMPORTANT: To guarantee good functioning, the probe should be centered horizontally and vertically at 1/3 from the bottom of the tilt window (when machine drum is empty).

Control Function Test

The washer-extractor should be cleaned after the installation is complete. A function test should then be executed on the unloaded machine:

1. Verify that power supply voltage and phase are correct in accordance with the washer-extractor's requirements.
2. Open manual shut-off valves to the washer-extractor.
3. Press the Emergency Stop button.
4. Apply power to the washer-extractor.
5. Release the Emergency Stop button.
6. Check the door interlock before starting operation:
 - a. Attempt to start the washer with the door open. The washer-extractor should not start with the door open.

- b. Close the door without locking it and attempt to start the washer. The washer should not start with the door unlocked.
- c. Close and lock the door and start a cycle. Attempt to open the door while the cycle is in progress. The door should not open.

If the door lock and interlock are not functioning properly, call a service technician.

7. For standard processing, select a cycle. Then press the Start keypad.

Run a complete cycle, checking operation of water inlet valves, drain, and extract functions.

8. Cylinder rotation must be clockwise in an extract step for all models. If rotation is not correct, disconnect power. A qualified electrician must reverse any two leads between the AC drive and the main drive motor. Refer to *Figure 18*.

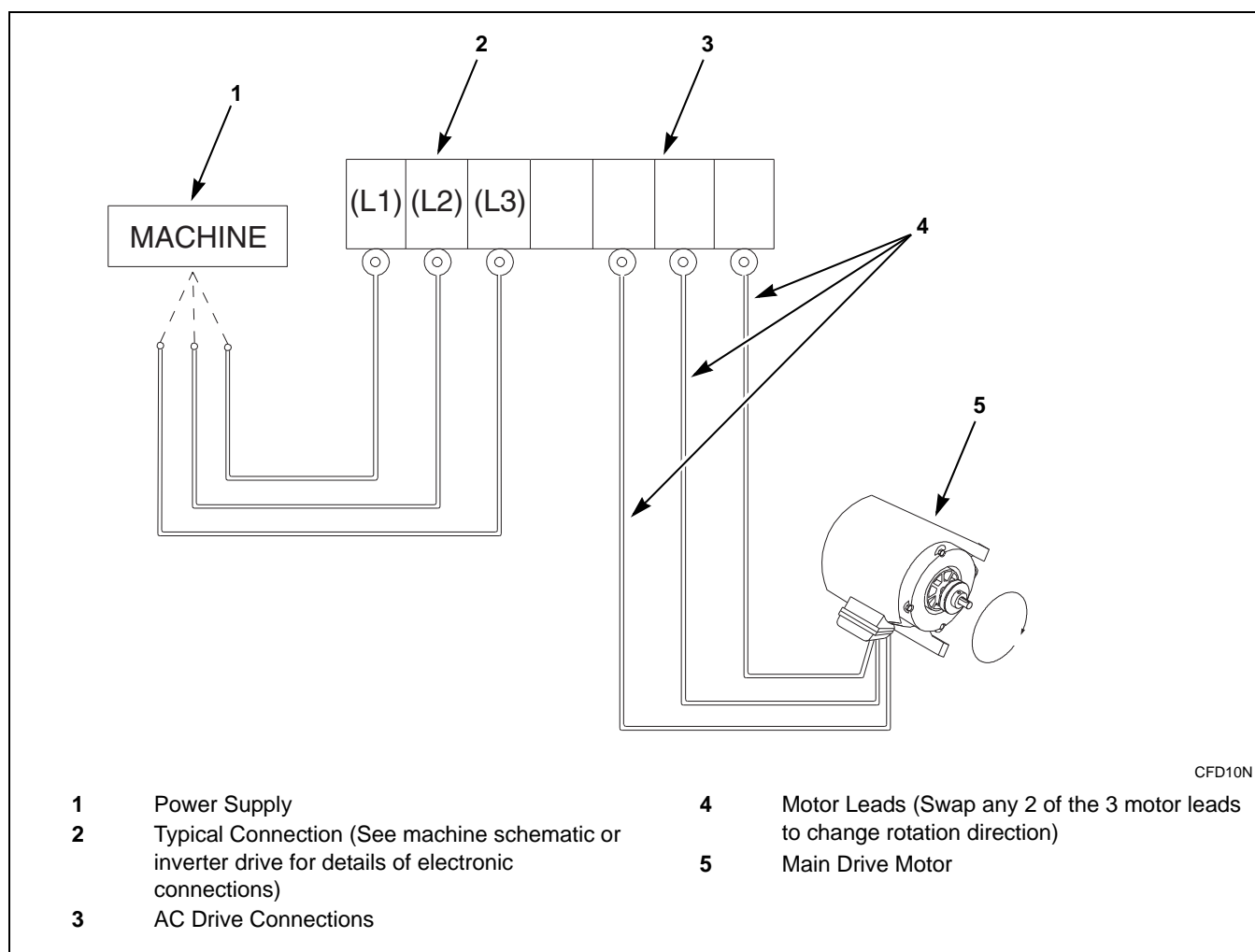

Figure 18