

ELECTRIC BASS

TRB-5 II/ TRB-5 IIF

SERVICE MANUAL



TRB-5II

■ CONTENTS

OVERALL ASSEMBLY	2
ELECTRICAL PARTS	4
CIRCUIT BOARD	6
CIRCUIT DIAGRAM	7
WIRING	8
SPECIFICATIONS	8

OVERALL ASSEMBLY

E11 Bridge Assembly BPX-5D ; GOLD (QC425400)

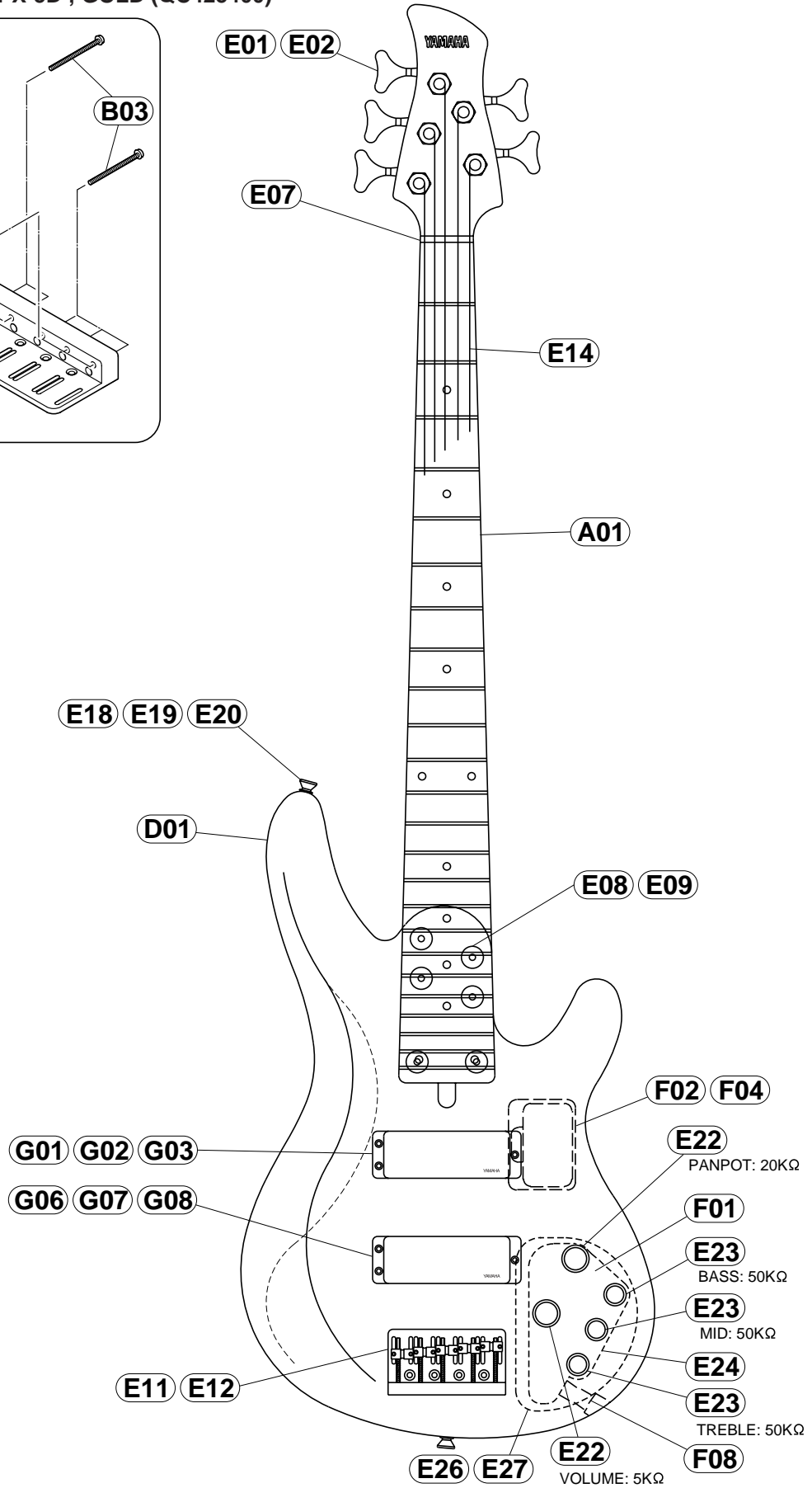
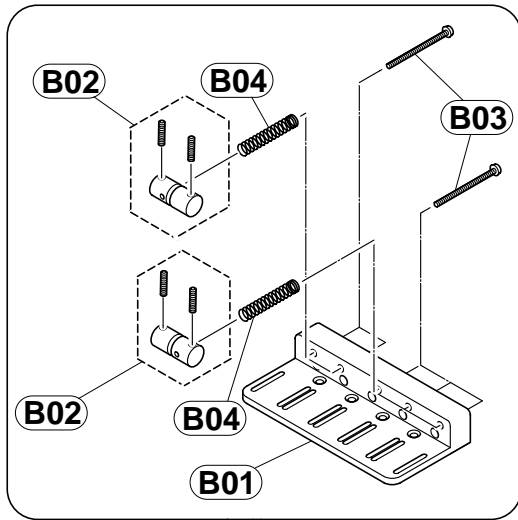

REF.NO.	PART NO.	DESCRIPTION		REMARKS	QTY	RANK
		OVERALL ASSEMBLY		TRB-5II/TRB-5IIF		
* A01	DX809350	Neck Assembly		TRB-5II AMT		
* A01	DX809360	Neck Assembly		TRB-5II MGB		
* A01	DX809370	Neck Assembly		TRB-5II TLBIII		
* A01	DX809380	Neck Assembly		TRB-5IIF AMT		
* A01	DX809390	Neck Assembly		TRB-5IIF TLBIII		
A01a	AA809390	Square Washer				01
D01	--	Body				
E01	QC028300	Tuning Machine Assembly	GB70L+GB7 (GOLD)		3	08
E01	QC028400	Tuning Machine Assembly	GB70+GB7 (GOLD)		2	08
E02	EQ624100	Round Head Wood Screw	2.4X10 GOLD	(0370407)	5	02
* E07	QC428000	Nut	43mm			
E08	QC205200	Neck Joint Bushing	(BL)		6	04
E09	VI825000	Oval Head Tapping Screw	5.0X40 FCM3BL		6	01
* E11	QC425400	Bridge Assembly	BPX-5D (GOLD)			
E12	QA170100	Oval Head Tapping Screw	4.0X35 GOLD		4	01
E14	--	Strings	H4050	1set (AA82119)		
E18	QC224600	Strap Button	EP-B2 (GOLD)		2	02
E19	ER635250	Oval Head Tapping Screw	3.5X25 GOLD	(0370663)	2	02
E20	VB793700	Spacer Felt	(BL)		2	01
E22	QC205700	Knob Assembly	LEX B-22	VOLUME, PANPOT	2	07
E23	QC205800	Knob Assembly	LEX B-18	BASS, TREB, MID	3	07
* E24	QC429500	Sheet, Instruction				
* E26	QC425800	Back Cover	Electrical (BL)			
E27	EB620020	Oval Head Wood Screw	2.7X13 FCM3BL		5	03
* F01	QC432100	Electrical Unit	(1) 3-BAND EQ.			
F02	VK505700	Box for Dry Cell	(2)			07
F04	QC025000	Pan Head Tapping Screw	3.0X8 FCM3BL		2	
* F08	QC437300	Electrical Unit (Jack Assy)	(3)			
* G01	QC428900	Pickup Assembly		Front		
* G02	QC325300	Pickup Spring			3	
G03	EM830230	Pan Head Tapping Screw	3.0X30 FCM3BL		3	01
* G06	QC429000	Pickup Assembly		Rear		
* G07	QC325300	Pickup Spring			3	
G08	EM830230	Pan Head Tapping Screw	3.0X30 FCM3BL		3	01
H01	QC354000	Accessory Unit (G-1)		1set		07
* B01	QC425400	Bridge Assembly	BPX-5D (GOLD)	P=18.0		
* B01	QC425500	Bridge Base	(GOLD)			
* B02	QC425300	Bridge Piece Assembly	(GOLD) with screw	with set screw (M3X12)	5	
B03	EA330400	Pan Head Screw	3.0X40 FCM3BL		5	01
* B04	AX818240	Spring	(BL) 30mm	1-2 string	2	
* B04	AX818250	Spring	(BL) 25mm	3-5 string	3	

*: New Parts

RANK:Japan only

WARNING: CHEMICAL CONTENT NOTICE!

The solder used in the production of this product contains LEAD. In addition, other electrical/electronic and/or plastic (where applicable) components may also contain traces of chemicals found by the California Health and Welfare Agency (and possibly other entities) to cause cancer and/or birth defects or other reproductive harm.

DO NOT PLACE SOLDER, ELECTRICAL/ELECTRONIC OR PLASTIC COMPONENTS IN YOUR MOUTH FOR ANY REASON WHAT SO EVER!

Avoid prolonged, unprotected contact between solder and your skin! When soldering, do not inhale solder fumes or expose eyes to solder/flux vapor!

If you come in contact with solder or components located inside the enclosure of this product, wash your hands before handling food.

ELECTRICAL PARTS

REF NO.	PART NO.	DESCRIPTION		REMARKS	QTY	RANK
		ELECTRICAL PARTS				
*	QC432100	Electrical Unit	3-BAND EQ.			
*	IC1 IX808770	IC	OP200GP	OP AMP		
	IC2 IG070700	IC	TL062CP	OP AMP		07
	IC3 IG070700	IC	TL062CP	OP AMP		07
*	IC4 IX808780	IC	TLC7662BEP4			
*	Q1-4 IX808790	FET	2SK30ATM(O)			
*	D1-4 IX808800	Diode	E-301			
	D5 QC183900	Diode	1SR139-100			01
*	VR1 HX809140	Rotary Variable Resistor	EWCE6AF22B24 20K	PANPOT		
*	VR2 HX809150	Rotary Variable Resistor	EWCE6AF22A53 5K	VOLUME		
*	VR3 HX809160	Rotary Variable Resistor	EWCE6AF22B54 50K	EQUALIZER BASS		
*	VR4 HX809160	Rotary Variable Resistor	EWCE6AF22B54 50K	EQUALIZER MID		
*	VR5 HX809160	Rotary Variable Resistor	EWCE6AF22B54 50K	EQUALIZER TREBLE		
*	VR7 HX809170	Trimmer Potentiometer	EVND8AA0 BQ3 4.7K			
*	VR8 HX809170	Trimmer Potentiometer	EVND8AA0 BQ3 4.7K			
	CN1 LB918020	Connector	B2B-XH-A 2P	FRONT PICKUP		01
	CN2 LB918020	Connector	B2B-XH-A 2P	REAR PICKUP		01
	CN3 LB918040	Connector	B4B-XH-A 4P	OUTPUT JACK		01
	CN4 LB918020	Connector	B2B-XH-A 2P	BATTERY		01
*	L1-4 GX804490	Ciol	ELEXG101KA 100uH			
	C1-4 FP355100	Tantalum Capacitor	0.1uF/16V (35V)			02
*	C05 FX804200	Electlytic Cap.	22u/16V R3A-16V220			
*	C06 FX804200	Electlytic Cap.	22u/16V R3A-16V220			
	C31 UI137100	Electlytic Cap.	10u/16V RC3-16V100			01
	C32 FG444100	Ceramic Capacitor	0.01uF			01
*	C33 FX804200	Electlytic Cap.	22u/16V R3A-16V220			
	C34 UI137100	Electlytic Cap.	10u/16V RC3-16V100			01
	C35 FG444100	Ceramic Capacitor	0.01uF			01
	C36 UI137100	Electlytic Cap.	10u/16V RC3-16V100			01
	C37 FG444100	Ceramic Capacitor	0.01uF			01
	C38 UI137100	Electlytic Cap.	10u/16V RC3-16V100			01
*	C39 UI166100	Electlytic Cap.	1u/16V RC3-50V010M			
*	C40 UI166100	Electlytic Cap.	1u/16V RC3-50V010M			
	C41 FG444100	Ceramic Capacitor	0.01uF			01
	C42 FG444100	Ceramic Capacitor	0.01uF			01
	C51 FG212100	Ceramic Capacitor	100pF			01
	C52 FG212100	Ceramic Capacitor	100pF			01
*	C53 FX804200	Electlytic Cap.	22u/16V R3A-16V220			
*	C61 UA154330	Mylar Capacitor	0.033uF			
	C62 UA155100	Mylar Capacitor	0.1uF			01
*	C63 UI166100	Electlytic Cap.	1u/16V RC3-50V010M			
	C71 UA154220	Mylar Capacitor	0.022uF			01
	C72 UA154220	Mylar Capacitor	0.022uF			01
	C73 FG212100	Ceramic Capacitor	100pF			01
	C74 UA153100	Mylar Capacitor	1000pF			01
*	C81 UA153220	Mylar Capacitor	2200pF			
*	C82 UA153150	Mylar Capacitor	1500pF			
	C83 FG212100	Ceramic Capacitor	100pF			01
	C84 FG212330	Ceramic Capacitor	330pF			01
	C85 FG212330	Ceramic Capacitor	330pF			01
*	R1-4 HF559100	Carbon Resistor	1.0M 1/6W J			
*	R5-8 HF559220	Carbon Resistor	2.2M 1/6W J			
	R09 HF556680	Carbon Resistor	6.8K 1/6W J			01
*	R10 HF556470	Carbon Resistor	4.7K 1/6W J			
	R11 HF556680	Carbon Resistor	6.8K 1/6W J			01
*	R12 HF556470	Carbon Resistor	4.7K 1/6W J			
	R13 HF557100	Carbon Resistor	10K 1/6W J			01
	R14 HF557100	Carbon Resistor	10K 1/6W J			01
*	R15 HF556470	Carbon Resistor	4.7K 1/6W J			
*	R16 HF556470	Carbon Resistor	4.7K 1/6W J			
*	R21 HF558470	Carbon Resistor	470K 1/6W J			
*	R23 HF557220	Carbon Resistor	22K 1/6W J			
*	R31 HF557330	Carbon Resistor	33K 1/6W J			
*	R32 HF557270	Carbon Resistor	27K 1/6W J			

*: New Parts

RANK:Japan only

REF NO.	PART NO.	DESCRIPTION		REMARKS	QTY	RANK
*	R51	HF557470	Carbon Resistor	47K 1/6W J		
*	R52	HF557470	Carbon Resistor	47K 1/6W J		
*	R53	HF557220	Carbon Resistor	22K 1/6W J		
*	R54	HF554330	Carbon Resistor	33 1/6W J		
*	R55	HF557180	Carbon Resistor	18K 1/6W J		
*	R56	HF557220	Carbon Resistor	22K 1/6W J		
*	R57	HF554330	Carbon Resistor	33 1/6W J		
*	R61	HF557330	Carbon Resistor	33K 1/6W J		
*	R62	HF557330	Carbon Resistor	33K 1/6W J		
*	R63	HF557120	Carbon Resistor	12K 1/6W J		
*	R64	HF557680	Carbon Resistor	68K 1/6W J		
*	R65	HF557470	Carbon Resistor	47K 1/6W J		
*	R71	HF558100	Carbon Resistor	100K 1/6W J		
*	R72	HF557510	Carbon Resistor	51K 1/6W J		
*	R73	HF557270	Carbon Resistor	27K 1/6W J		
	R74	HF557100	Carbon Resistor	10K 1/6W J		01
	R75	HF557100	Carbon Resistor	10K 1/6W J		01
*	R76	HF557180	Carbon Resistor	18K 1/6W J		
	R77	HF557100	Carbon Resistor	10K 1/6W J		01
*	R78	HF556220	Carbon Resistor	2.2K 1/6W J		
*	R79	HF557470	Carbon Resistor	47K 1/6W J		
*	R80	HF557470	Carbon Resistor	47K 1/6W J		
*	R81	HF557330	Carbon Resistor	33K 1/6W J		
*	R82	HF557470	Carbon Resistor	47K 1/6W J		
	R83	HF557100	Carbon Resistor	10K 1/6W J		01
	R84	HF557100	Carbon Resistor	10K 1/6W J		01
*	R85	HF557220	Carbon Resistor	22K 1/6W J		
	R86	HF557100	Carbon Resistor	10K 1/6W J		01
*	R87	HF556330	Carbon Resistor	3.3K 1/6W J		
*	R88	HF557470	Carbon Resistor	47K 1/6W J		
*	R89	HF557470	Carbon Resistor	47K 1/6W J		
*		QC434900	Hexagonal Nut			

*: New Parts

RANK:Japan only

CIRCUIT BOARD

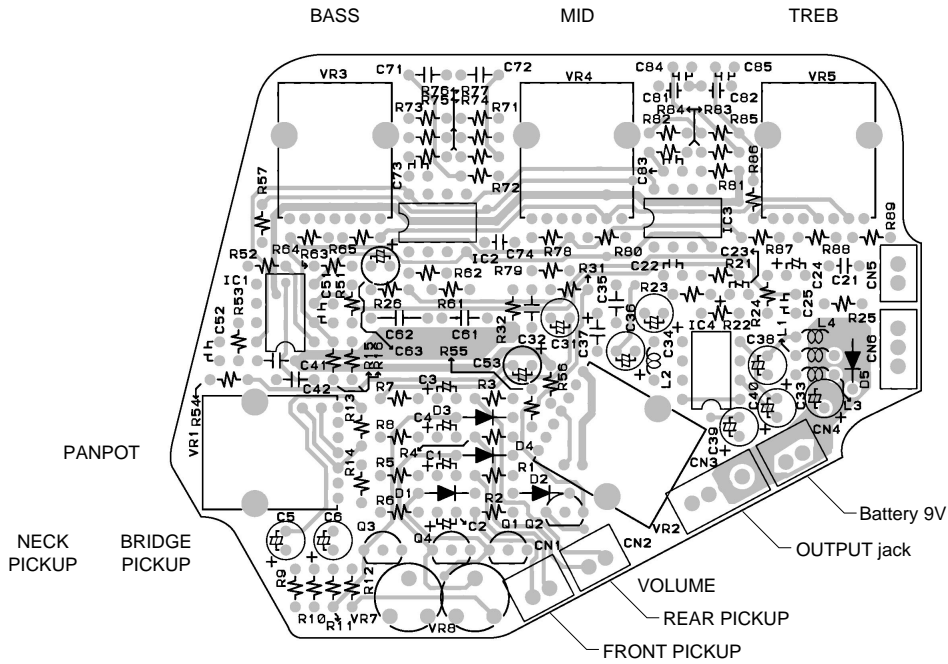

Component side

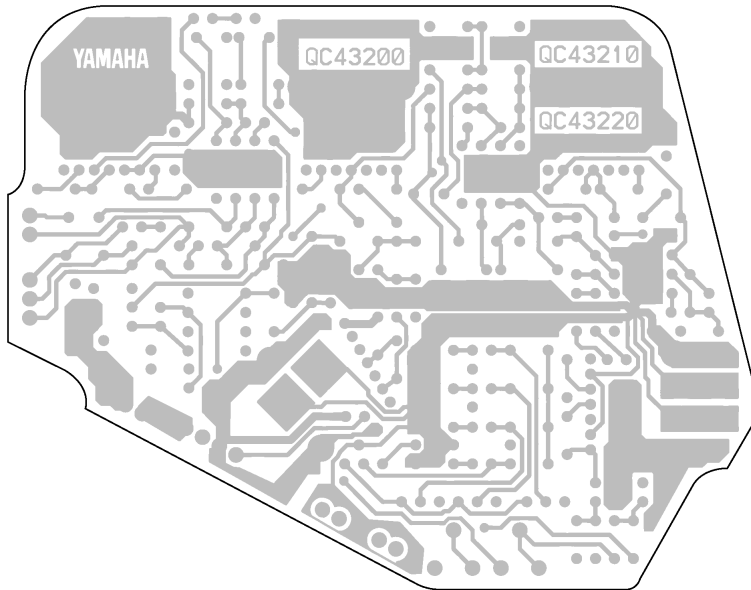

Pattern side

CIRCUIT DIAGRAM

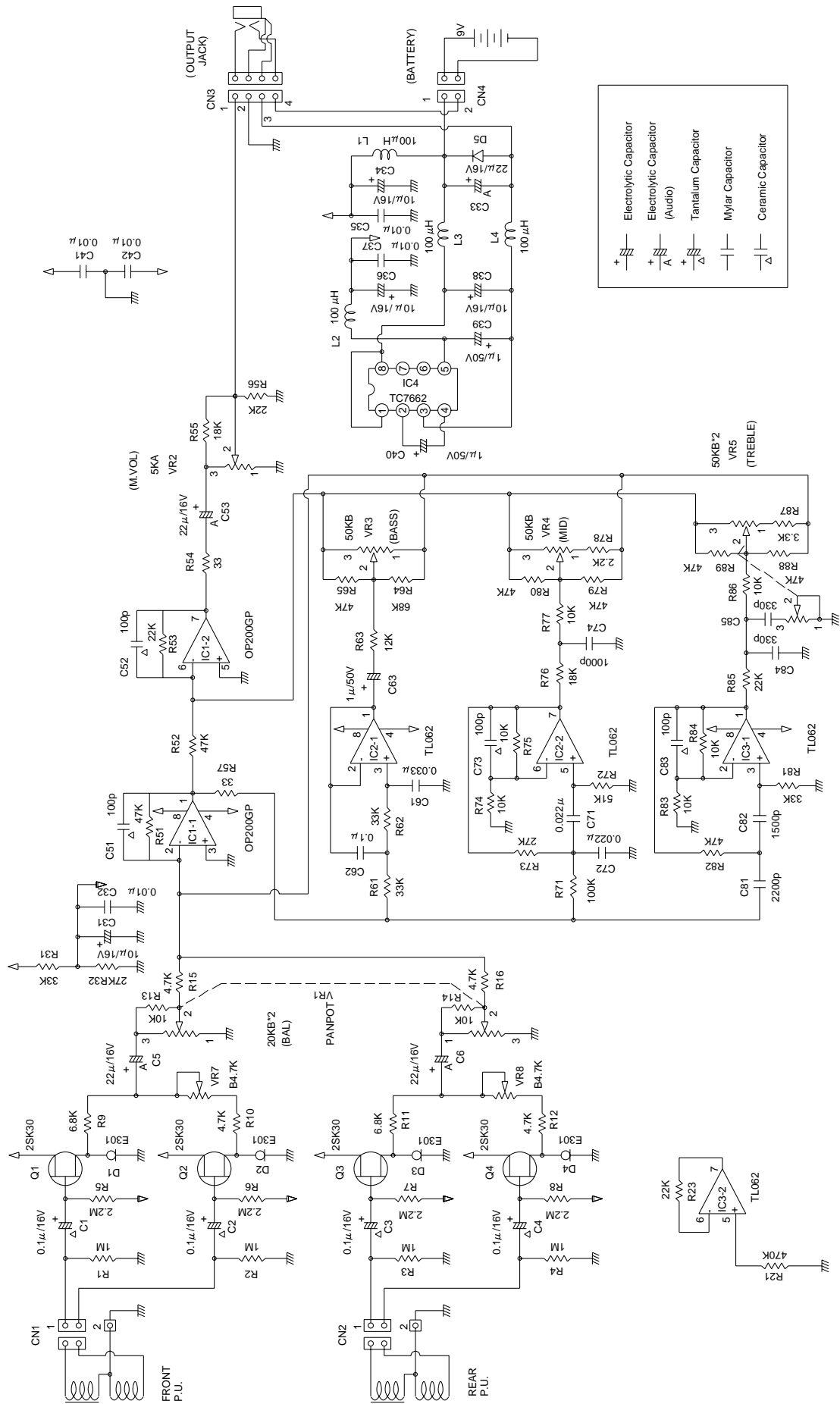

WIRING

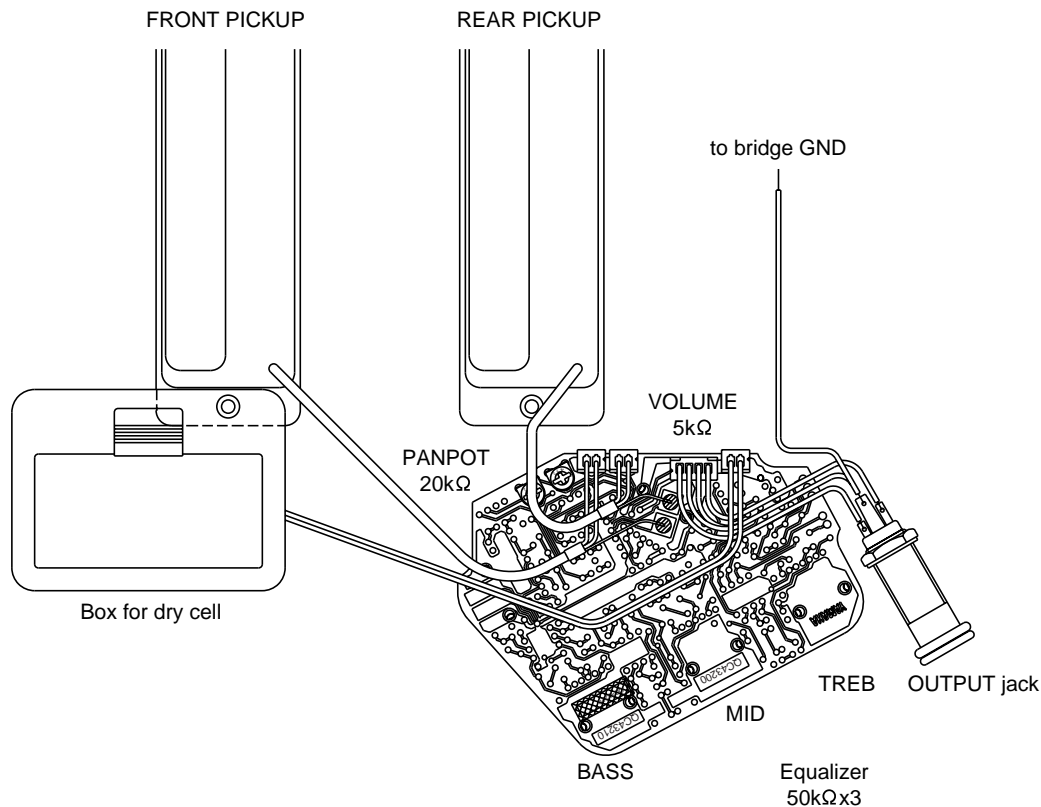

SPECIFICATIONS

STANDARD SPECIFICATIONS

Scale Length	889.0mm
Body-Neck Construction	Bolt On
Length	1163.0mm
Width	334.5mm
Net Weight	4.5kg

COLOR

Body	
5II/5IIF:AMT	Amber Burst
5II:MGB	Magenta Burst
5II/5IIF:TLBII	Translucent Blue
Neck	
5II/5IIF:AMT	Amber Burst
5II:MGB	Magenta Burst
5II/5IIF:TLBII	Translucent Blue

BODY

Material	Light Ash
Body Depth	41.0mm

FINGERBOARD

Material	Rosewood
Fingerboard Width	0-F 43.0mm, 12-F 65.9mm
No. of Frets	24

NECK

Material	Maple
Neck Thickness	1-F 20.5mm, 12-F 25.0mm

PARTS

Hardware	Gold Plated
Nut	Bone
Bridge	BPX-5D:Gold
Strings	YAMAHA H4050

CONTROLS

Volume	5kΩ X1
Balance	20kΩ X1
Equalizer	50kΩ X3

PICKUPS

Front/Rear	Double Coil
Magnet	
Front/Rear	AlnicoV