

# ELECTRIC GUITAR RGX 121S

## SERVICE MANUAL



This document is printed on chlorine free (ECF) paper with soy ink.

### ■ CONTENTS

OVERALL ASSEMBLY .....	2
CIRCUIT DIAGRAM .....	4
WIRING .....	4
SPECIFICATIONS .....	5

# OVERALL ASSEMBLY(総組立)

## E27 Bridge Assembly: YS-11 (Black)

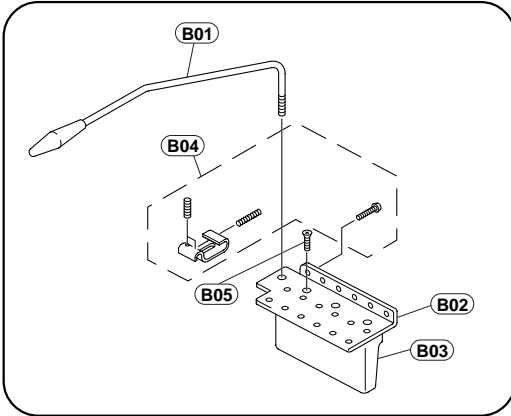

## • Jack Installation(JACK 部詳細)

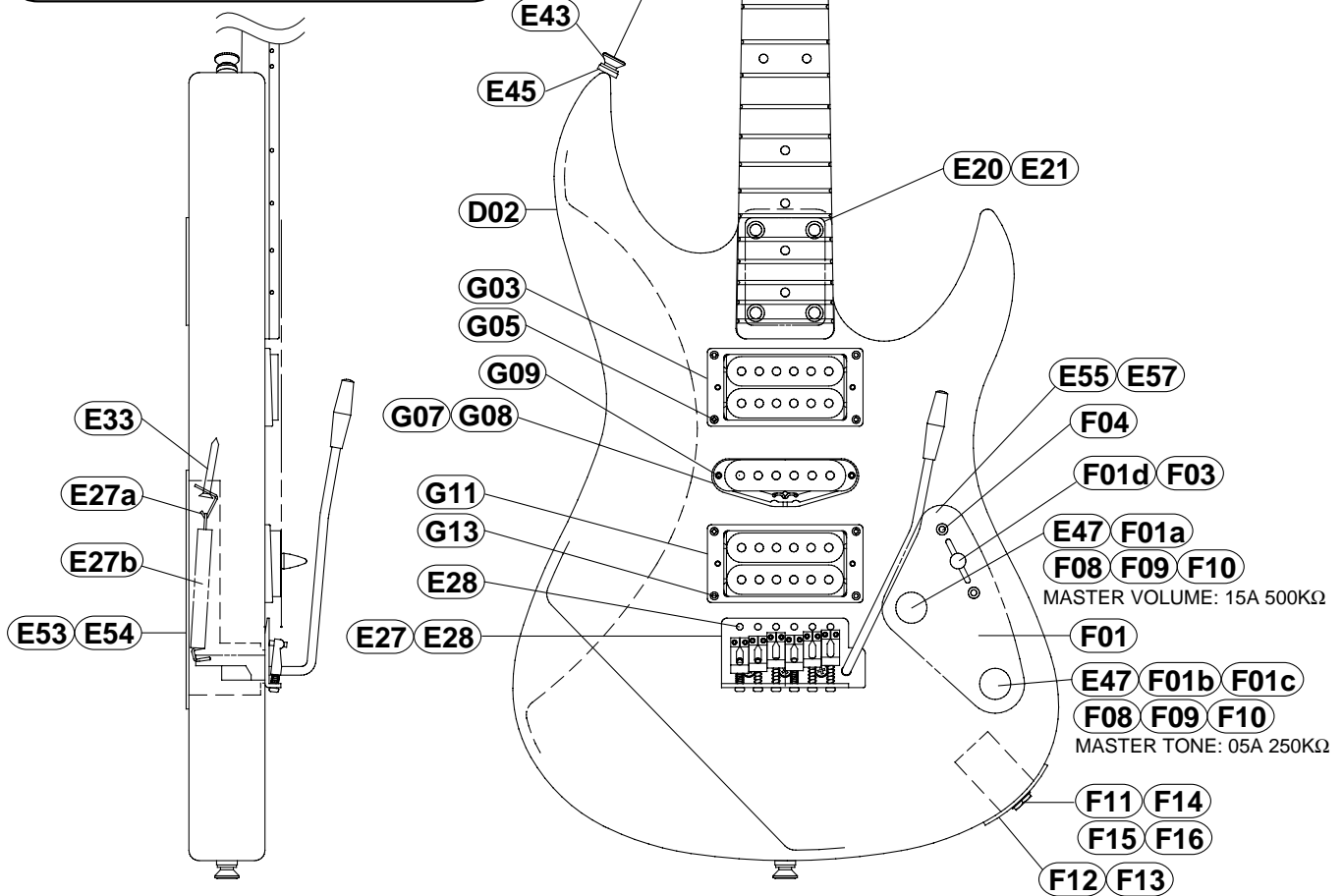
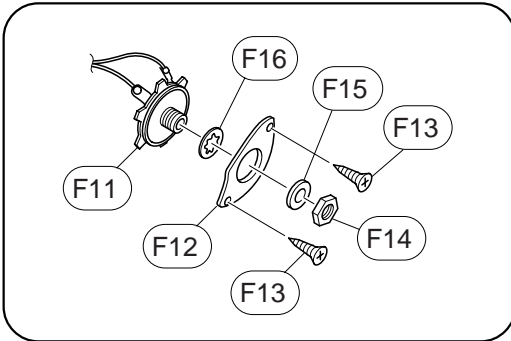

REF NO.	PART NO.	DESCRIPTION		REMARKS	QTY	RANK
* A01	AAX19490	OVERALL ASSEMBLY		RGX 121S		
A01a	--	Neck Assembly		SBL		
		Seal		(QC59460)		
D02	--	Body				
E01	QC296300	Tuning Machine Assembly	RM1273 (Black)	1set		12
E06	QC201700	String Guide	Black			01
E07	QC370200	Spacer	Black			02
E08	EA620080	Round Head Wood Screw	2.1X10 (Black)			
E10	VD955900	Rod Cover	Black			01
E11	03706220	Oval Head Wood Screw	2.1X10 (Black)			01
E12	VB344800	Nut	Black			04
E20	QC201900	Neck Plate	Black			06
E21	EN240070	Oval Head Tapping Screw	4.0X45 (Black)		4	
E27	QC335200	Bridge Assembly	YS-11 (Black)		2	13
E27a	--	Arm Spring Plate				
E27b	--	Arm Spring			3	
E28	QC202100	Round Head Wood Screw	3.1X25 (Black)		6	
E33	EN240060	Oval Head Tapping Screw	4.0X45 (Nickel plate)		2	01
E39	--	Strings	XL-120	1set (QC16510)		
E43	VB563800	End Pin	Black		2	01
E44	VD816500	Oval Head Tapping Screw	3.0X25 (Black)		2	01
E45	VB793700	Spacer	Black		2	01
E47	VK739800	Knob Assembly	H=16.5 (Black)		2	05
E53	CB822600	Back Cover	Bridge (Black)		1	04
E54	EB620020	Oval Head Wood Screw	2.7X13 (Black)		6	03
E55	QC019200	Back Cover	1 (Black)			05
E57	EB620020	Oval Head Wood Screw	2.7X13 (Black)		3	03
F01	--	Electrical Unit		1set (QC16930)		
F01a	HS120070	Variable Resistor	15A 500K ohm	VOLUME		03
F01b	HS120100	Variable Resistor	05A 250K ohm	TONE		03
F01c	UA114220	Mylar Cap.	0.022uF			01
F01d	KA502000	Pickup Switch	5-P			08
F03	CB821810	Knob	Black			02
F04	03755170	Oval Head Screw	3.0X8 (Black)		2	01
F08	--	Hexagonal Nut			2	
F09	--	Flat Washer			2	
F10	--	Toothed Lock Washer			2	
F11	QC234800	Electrical unit (Jack)		1set		06
F12	VB518300	Jack Panel	Black			05
F13	EB620020	Oval Head Wood Screw	2.7X13 (Black)		2	03
F14	AA820860	Hexagonal Nut	Black			01
F15	AA820850	Flat Washer	Black			01
F16	ET800180	Toothed Lock Washer	9S		2	01
G03	QC457300	Pickup Assembly		FRONT		10
G05	20454100	Oval Head Tapping Screw	2.4X16 (Black)		4	01
G07	QC163800	Pickup Assembly		CENTER		09
G08	QA197100	Pickup Spring			2	01
G09	QC007000	Round Head Wood Screw	2.4X25 (Black)		2	01
G11	QC371100	Pickup Assembly		REAR		10
G13	20454100	Oval Head Tapping Screw	2.4X16 (Black)		4	01
H01	--	Accessory Unit	G-2	1set (QC35410)		
	QA262600	Cord	D			05
	--	Wrench	#5			
	--	Wrench	#2			
	--	Wrench	#1.5			
B01	QC335200	Bridge Assembly	YS-11 (Black)			13
B02	AX817690	Arm				06
B02	AX817910	Bridge Base				06
B03	AX814050	Bridge Tail				06
B04	AX817920	Bridge Piece Assembly			6	05
B05	EX803790	Flat Head Screw	4.0X9		3	01

\*: New Parts

RANK: Japan only

## CIRCUIT DIAGRAM

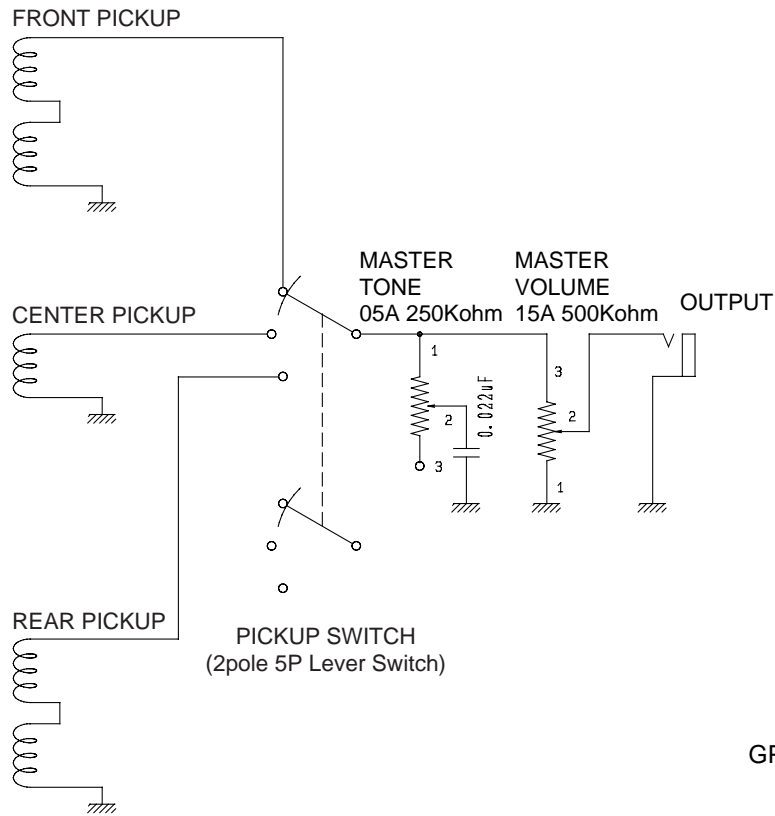

GP21-04

## WIRING

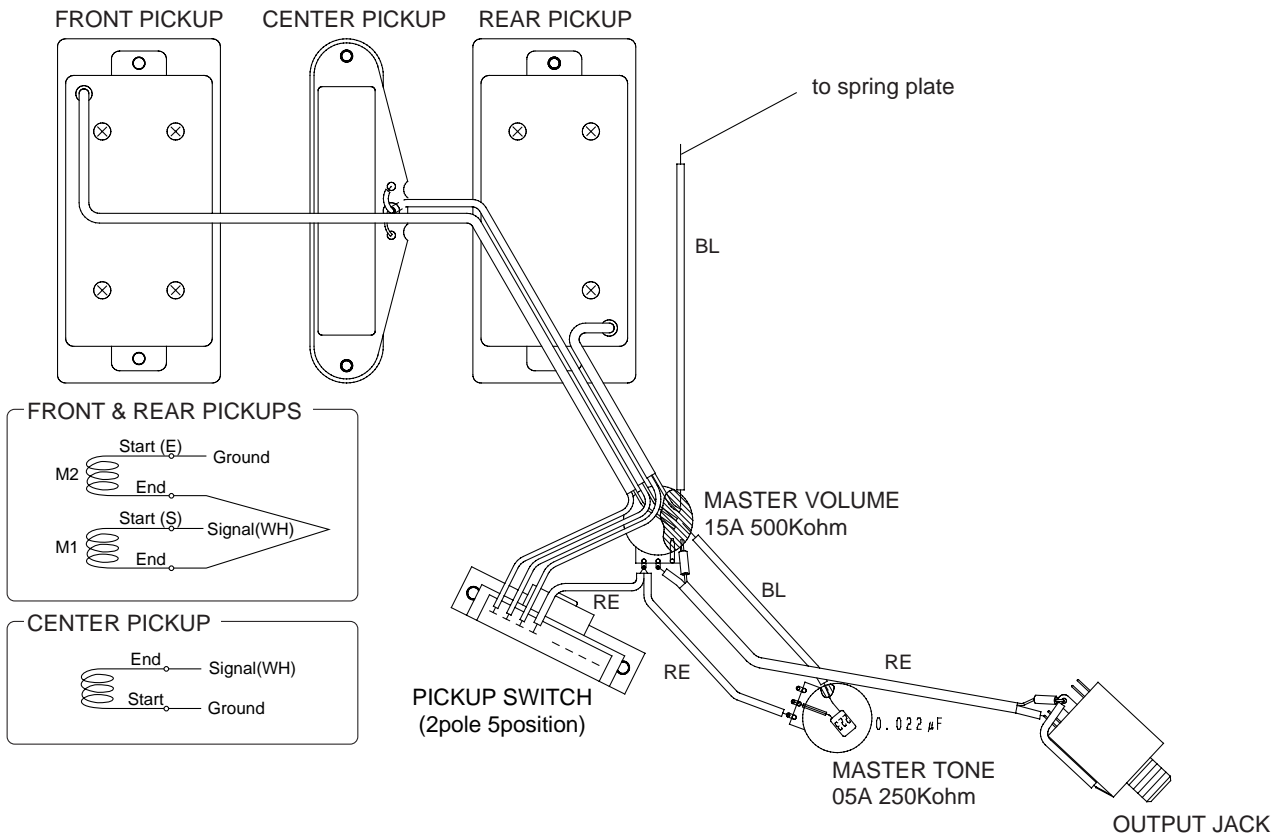

## ■ SPECIFICATIONS

### ● STANDARD SPECIFICATIONS

Scale Length ..... 648mm  
 Body-Neck Construction ..... Bolt On  
 Length ..... 975.5mm  
 Width ..... 315.8mm  
 Net Weight ..... 3.4kg

### ● COLOR

Body

SBL ..... Satin Black  
 SLB ..... Sheiby Blue  
 MRB ..... Mist Raspberry  
 MPP ..... Mist Purple

Neck

SBL ..... Satin Black

### ● BODY

Material ..... Alder  
 Body Depth ..... 44mm

### ● FINGERBOARD

Material ..... Rose  
 Fingerboard Width ..... 0-F 41 mm, 12-F 51.4 mm  
 No. of Frets ..... 22

### ● NECK

Material ..... Maple  
 Neck Thickness ..... 1-F 19.0 mm, 12-F 21.7 mm

### ● PARTS

Hardware ..... Black  
 Nut ..... Urea  
 Bridge ..... YS-11: Black  
 Strings ..... Super Light: XL-120

### ● CONTROLS

Volume ..... 15A 500K $\Omega$  x 1  
 Tone ..... 05A 250K $\Omega$  x 1  
 Pickup Switch ..... 2pole 5P Lever Switch

### ● PICKUPS

Front/Rear ..... Open Humbucking  
 Center ..... Single Coil  
 Magnet  
 Front/Center/Rear ..... Ferrite

### **WARNING : CHEMICAL CONTENT NOTICE!**

The solder used in the production of this product contains LEAD. In addition, other electrical/electronic and/or plastic (Where applicable) components may also contain traces of chemicals found by the California Health and Welfare Agency (and possibly other entities) to cause cancer and/or birth defects or other reproductive harm.

**DO NOT PLACE SOLDER, ELECTRICAL/ELECTRONIC OR PLASTIC COMPONENTS IN YOUR MOUTH FOR ANY REASON WHAT SO EVER!**

Avoid prolonged, unprotected contact between solder and your skin! When soldering, do not inhale solder fumes or expose eyes to solder/flux vapor!

If you come in contact with solder or components located inside the enclosure of this product, wash your hands before handling food.