

Home Care Technical Specification

Tool Free Transfer Bench

DN7065

Stock Numbers:

- **DN7065 – Tool-Free Transfer Bench**
White

Dimensions:

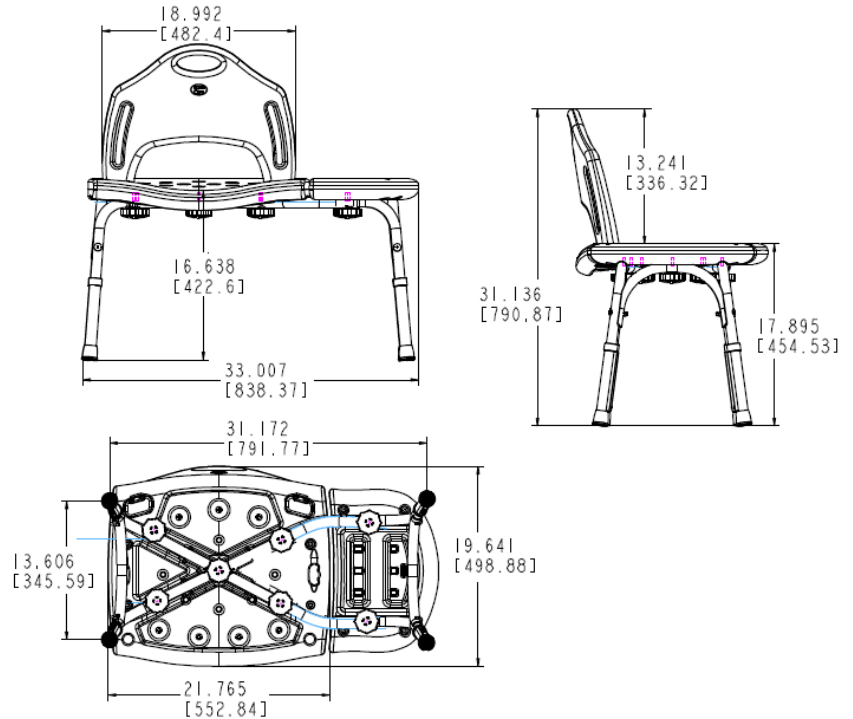

Materials:

Tool-Free Transfer Bench is made of ABS Plastic, Aluminum, EPDM, and Stainless.

**ASSEMBLY TESTED
TO CONFIRM ADA
COMPLIANCE**



WARNING

TO PREVENT SERIOUS OR FATAL INJURY: Insure product is assembled, adjusted and used properly. **FOR USE ONLY BY PERSONS WEIGHING LESS THAN 250 POUNDS.** Failure to follow correct assembly and/or adjustment procedures can make the seat unstable. **ALL FOUR LEGS MUST BE LOCKED IN PLACE AT THE SAME HEIGHT. DO NOT** jump on, stand on or tilt. Contact CSI immediately at 1-800-882-0116 if any components are missing or damaged. Do not modify or substitute any components. **FOR QUESTIONS OR ASSISTANCE WITH ASSEMBLY CONTACT CSI AT 1-800-882-0116.** Consult healthcare professional for advice and instructions specific to user's needs before use.

Installation Instructions:

1. Determine orientation of chair relative to water supply in order for transfer bench to be positioned outside of bathtub.
2. Locate the two under seat support beams: Hold the pieces by the straight end with the curved end away from you.
3. Locate the flat, indented area of each beam: Place the two flat areas together, so they are touching, and the two beams form an "X" shape.
4. Locate the leg unit with top posts that point inward: Align the posts with the straight ends of the crossed support beams on the small end of the "X".
5. Slide the top posts of the leg unit over the ends of the crossed support beams.
6. Take the remaining leg unit, with the top posts that point straight out, and align it with the curved end of the support beams, at the large side of the "X".
7. Slide the top posts of the leg unit over the ends of the crossed support beams.
8. Locate the transfer bench. Place it seat side down.
9. Place the curved ends of the crossed support beams into the grooves on the underside of the transfer bench, aligning the holes in the support beams with the holes inside the grooves.
10. Use the assembly knobs to attach the transfer bench to the support beams. Thread the washers onto the bolt, small lock washer first, followed by the cup washer.
11. Locate the large seat bottom. Place it under the support beams so that the center of the "X" slides into the center of the "X" shaped grooves on the large seat bottom.
- 12.

Stock Number: _____ **TF Transfer Bench**
By Creative Specialties



25300 AL MOEN DRIVE • NORTH OLMSTED, OH 44070
CORPORATE HEADQUARTERS: (800) 321-8809 • FAX: (800) 848-6636
INTERNATIONAL: (440) 962-2000 • FAX: (440) 962-2726
CUSTOMER SERVICE (USA): 800-882-0116 • FAX: (888) 379-2720
WWW.MOEN.COM

©Copyright Creative Specialties International

Literature #BA1370