

# INSTALLATION INSTRUCTION

## TABLE OF CONTENTS

FURNACE SPECIFICATIONS .....	2
GENERAL INFORMATION .....	3
INSTALLATION STANDARDS .....	3
CODE COMPLIANCE .....	3
HIGH ALTITUDE INSTALLATION .....	3
MINIMUM FURNACE CLEARANCES .....	3
RETURN AIR REQUIREMENTS .....	4
CLOSET INSTALLATIONS .....	4
AIR DISTRIBUTION SYSTEMS .....	4
ROOF JACK .....	6
EXISTING FURNACE REPLACEMENT .....	6
NEW HOME INSTALLATION .....	6
INSTALLATION IN SNOW REGIONS .....	6
LOCATING AND CUTTING ROOF JACK OPENING .....	6
INSTALLING ROOF JACK IN ROOF .....	6
DUCT CONNECTORS .....	9
INSTALLATION OF SCREW ATTACHMENT DUCT CONNECTOR .....	10
INSTALLATION OF TAB ATTACHMENT DUCT CONNECTORS .....	10
INSTALLATION OF THE FURNACE .....	11
CEILING RINGS .....	12
ELECTRICAL WIRING .....	12
CONNECT POWER SUPPLY WIRES .....	12
CONNECT THERMOSTAT WIRES .....	12
WALL THERMOSTAT .....	13
WIRING DIAGRAMS .....	14
GAS PIPING .....	19
INSTALLATION AND CHECKING OF GAS LINE .....	19
HIGH ALTITUDE DERATION CHART .....	21
REPAIR PARTS LIST .....	22

**CAUTION: READ ALL SAFETY GUIDES BEFORE  
YOU START TO INSTALL YOUR UNIT.**

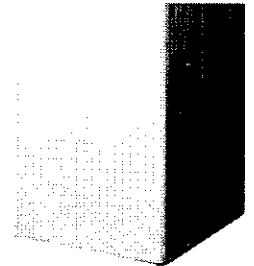
**SAVE THIS MANUAL**

## SEALED COMBUSTION DOWNFLOW GAS FURNACE MODELS: DGAA, DGAH, DGPA, AND DGPH



### For Installation In:

1. Manufactured (Mobile) Homes
2. Recreational Vehicles & Park Models
3. Modular Homes & Buildings



**IMPORTANT** - Only individuals having proven experience with this type of equipment should attempt to perform set-up.

Proper furnace set-up and adjustment is the responsibility of the retailer/homeowner and is not covered under warranty.

### FURNACE START-UP CHECK LIST

- Has roof jack crown been correctly installed?
- Has furnace gas valve and burner orifice been correctly converted for Propane. gas where applicable?
- Has furnace gas valve been de-rated for altitudes above 2000 feet where applicable?
- Is gas line outlet pressure properly set for fuel type? (natural gas is 3.5" W.C.; Propane is 10" W.C.)
- Is cross-over duct installed per home builder and UPG installation instructions?
- Has furnace been operated through a complete heating cycle?
- Has the pilot flame been adjusted properly? (DGPH and DGPA Models)

## FURNACE SPECIFICATIONS

DGAA — AUTOMATIC IGNITION — WITH BUILT-IN COIL CABINET — 4 TON - A/C READY			
MODEL NO.	Factory Equipped for use with	Input/BTUH	Output/BTUH
DGAA056BDTA	NATURAL GAS	56,000	45,000
DGAA070BDTA	NATURAL GAS	70,000	56,000
DGAA077BDTA	NATURAL GAS	77,000	62,000
DGAA090BDTA	NATURAL GAS	90,000	72,000

DGPA — STANDING PILOT — WITH BUILT-IN COIL CABINET — 3 TON - A/C READY			
MODEL NO.	Factory Equipped for use with	Input/BTUH	Output/BTUH
DGPA056ABTA	NATURAL GAS	56,000	45,000
DGPA070ABTA	NATURAL GAS	70,000	56,000
DGPA077ABTA	NATURAL GAS	77,000	62,000
DGPA090ABTA	NATURAL GAS	90,000	72,000

DGPH — STANDING PILOT — WITH BUILT-IN COIL CABINET — 3 TON - NO A/C CONTROLS			
MODEL NO.	Factory Equipped for use with	Input/BTUH	Output/BTUH
DGPH056ABTA	NATURAL GAS	56,000	45,000
DGPH070ABTA	NATURAL GAS	70,000	56,000
DGPH077ABTA	NATURAL GAS	77,000	62,000
DGPH090ABTA	NATURAL GAS	90,000	72,000

DGAH — AUTOMATIC IGNITION — HEATING ONLY — NO COIL CABINET			
MODEL NO.	Factory Equipped for use with	Input/BTUH	Output/BTUH
DGAH056BBSA	NATURAL GAS	56,000	45,000
DGAH077BBSA	NATURAL GAS	77,000	62,000

ELECTRICAL SPECIFICATIONS	
Electrical Power Supply	115 Volts - 60 Hz - 1 Phase
Breaker or Fuse	15 Amp
Thermostat Circuit	24 Volt - 60 Hz - 40 VA
Nominal Anticipator Setting	.50
Gas Valve Inlet	1/2" NFPT

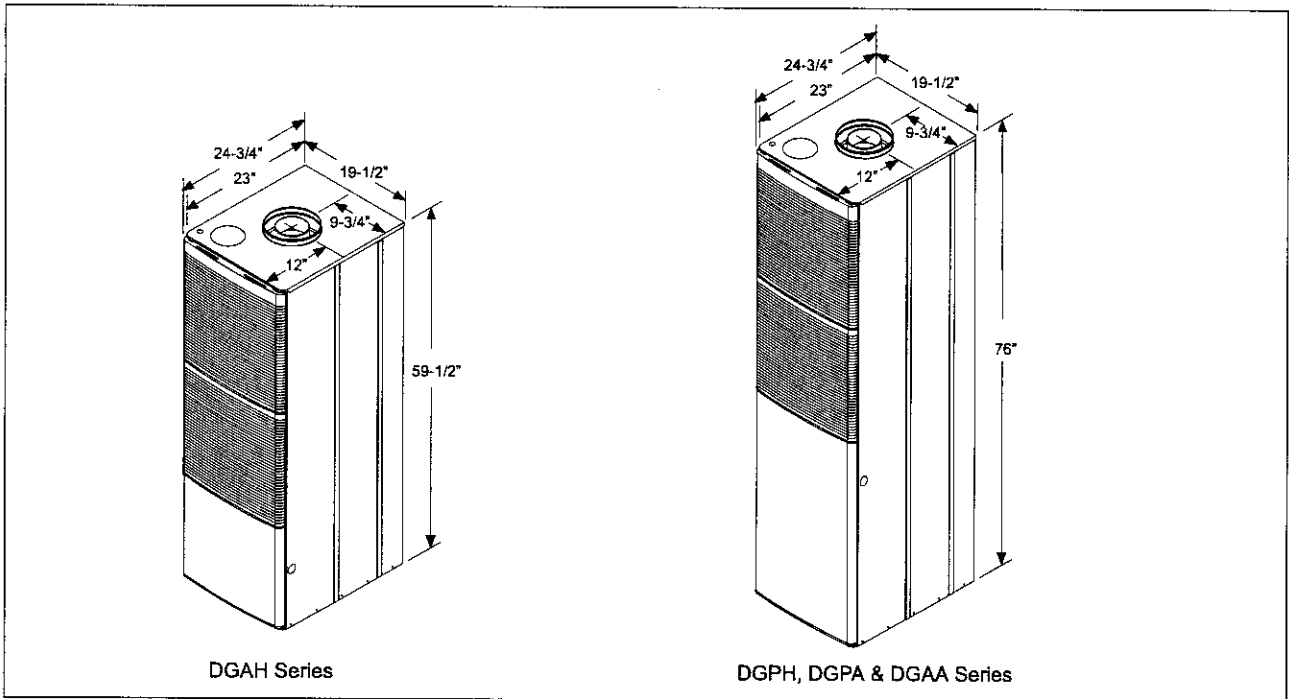


FIGURE 1 : Furnace Dimensions

## GENERAL INFORMATION

**NOTE:** The words "Shall" or "Must" indicate a requirement which is essential to satisfactory and safe product performance.

The words "Should" or "May" indicate a recommendation or advice which is not essential and not required but which may be useful or helpful.

**IMPORTANT** - These instructions are primarily intended to assist qualified individuals experienced in the proper installation of heating and/ or air conditioning appliances. Some local codes require licensed installation service personnel for this type of equipment. Read all instructions carefully before starting the installation.

### ▲ WARNING

*Improper installation may damage equipment, can create a shock hazard, and will void the warranty.*

*The furnace shall be installed so the electrical components are protected from water.*

*The furnace is not to be used for temporary heating of buildings or structures under construction.*

*Do not test the fuel system at more than 14 inches water column after furnace has been connected to the fuel line. Such testing may void the warranty. Any test run above 14 inches water column may damage the furnace control valve which could cause an explosion, fire, or asphyxiation.*

## INSTALLATION STANDARDS

### CODE COMPLIANCE

The installer must comply with all local codes and regulations which govern the installation of this appliance. Local codes and regulations shall take precedent over these regulations where applicable. In lieu of local codes, the appliance shall be installed in accordance with one or more of the following standards.

#### Manufactured homes in the U.S.A.:

1. Federal Manufactured Home Construction & Safety Standard (H.U.D. Title 24, Part 3280).
2. National Fuel Gas Code (ANSI-Z223.1, NFPA-54).
3. National Electrical Code (NFPA 70).

#### Manufactured homes in Canada:

1. Natural Gas and Propane Installation Code (CAN/CSA B149.1).
2. Canadian Electrical Code, Part 1 (CSA C22.1)

#### Recreational Vehicles in U.S.A.:

1. Standard on Recreational Vehicles (NFPA 1192, formerly NFPA 501C).
2. National Electrical Code (NFPA 70).

#### Recreational Vehicles in Canada:

1. Unit installation shall comply with current CSA standard CAN/CGA-Z240.4.2 - Installation Requirements for Propane Appliances and Equipment in Recreational Vehicles.
2. Unit electrical wiring and grounding shall comply with current CSA standard C22.2 No. 148/CAN/CSA-Z240.6.2 - Electrical Requirements for recreational vehicles.

### HIGH ALTITUDE INSTALLATION

For elevation above 2,000 feet, derate furnace input 4% for each 1,000 feet of elevation above sea level. Derating is accomplished by reducing the orifice size. See Derating Chart for orifice size.

In Canada, for elevations from 2000 to 4500 feet derate by reducing gas manifold pressure to 3.0" W.C. for natural gas and 9.0" W.C. for LP gas.

### ▲ CAUTION

- Never attempt to alter or modify this furnace or any of its components.
- Never attempt to repair damaged or inoperable components. Such action could cause unsafe operation, explosion, fire and/or asphyxiation.
- If a malfunction has occurred, or if you feel that the furnace is not operating as it should, contact a qualified service agency or gas utility for assistance.

### MINIMUM FURNACE CLEARANCES

Access for servicing is an important factor in the location of any furnace. A minimum of 24 inches should be provided in front of the furnace for access to the heating elements and controls. This access may be provided by a closet door or by locating the furnace 24 inches from a facing wall or partition.

These furnaces are design certified for the following minimum clearances from combustible material in alcove or closet installation

**Table 1: MINIMUM CLEARANCES**

	CLOSET	ALCOVE
BACK	0"	0"
SIDES	0"	0"
FRONT	6"	24"
TOP	2"	2"
ROOF JACK	0"	0"
DUCT	0"	0"

## RETURN AIR REQUIREMENTS

### CLOSET INSTALLATIONS

#### Additional Requirements

Additional requirements for floor and ceiling return system for closet installed sealed combustion heating appliance are given in the next paragraph.

#### Floor or Ceiling Return Air System

Listed in the next paragraph are the conditions to be met by Manufactured Home Manufacturers to have U.L. acceptance of in-floor or ceiling return air systems of closet installed direct vent forced air heating appliances for Manufactured Homes to be sold in the United States.

1. The return-air opening into the closet, regardless of location, is to be sized not less than specified on the appliance's rating plate.
2. If the return-air opening is located in the floor of the closet (versus the vertical front or side wall), the opening is to be provided with means to prevent its inadvertent closure by a flat object placed over the opening.
3. The cross-sectional area of the return duct system (when located in the floor or ceiling of the manufactured home) leading into the closet is to be not less than that of the opening specified on the appliance's rating plate.
4. The total free area of openings in the floor or ceiling registers serving the return-air duct system is to be not less than 150% of the size of the opening specified on the appliance's rating plate. At least one such register is to be located where likelihood of its being covered by carpeting, boxes, and other objects is minimized.
5. Materials located in the return duct system have a flame spread classification of 200 or less.

6. Non-combustible pans having one-inch upturned flanges are located beneath openings in the floor return duct system.
7. Wiring materials located in the return duct system conform to Article 300-22 (B&C) of the National Electrical Code (NFPA-70).
8. Gas piping is not run in or through the return duct system.
9. The negative pressure in the closet as determined by test with the air-circulating fan operating at high heating speed and the closet door closed is to be not more negative than minus 0.05-inch water column.
10. For floor return systems, the manufactured home manufacturer or installer shall affix a prominent marking on or near the appliance where it is easily read when the closet door is open. The marking shall read:

**▲ WARNING**

*HAZARD OF ASPHYXIATION, DO NOT COVER OR RESTRICT FLOOR OPENING.*

### AIR DISTRIBUTION SYSTEMS

For proper air distribution, the supply duct system shall be designed so that the static pressure does not exceed the listed static pressure rating on the furnace rating plate.

Three typical distribution systems are illustrated in Figure 2.

Location, size and number of registers should be selected on the basis of best air distribution and floor plan of the home.

The Air Temperature Rise is to be adjusted to obtain a temperature rise within the range(s) specified on the furnace rating plate.

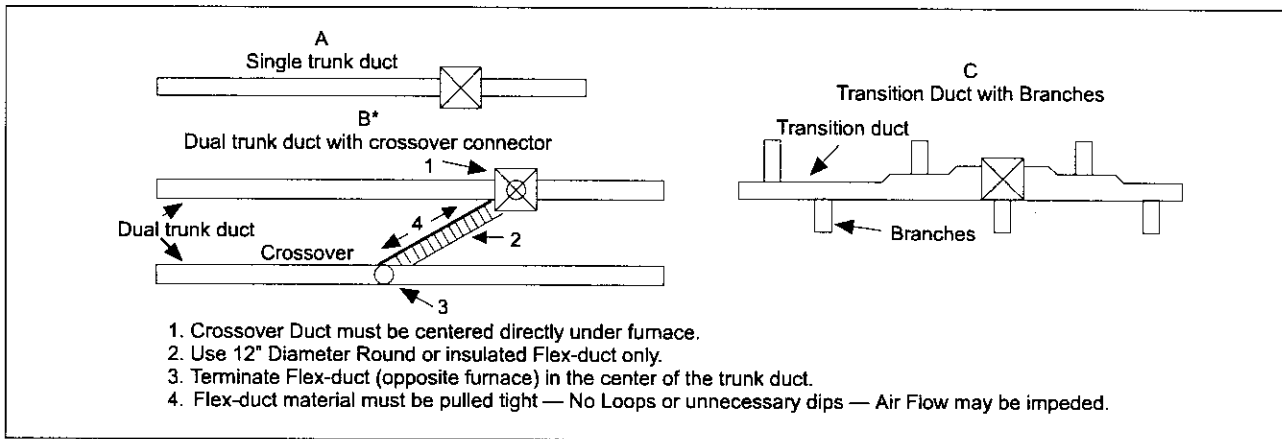
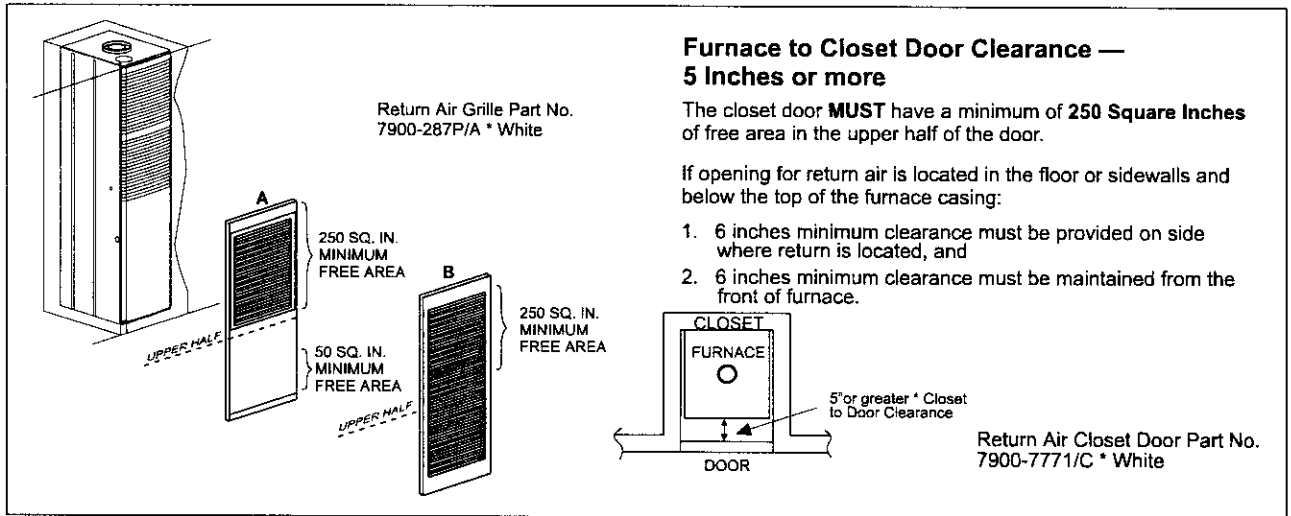
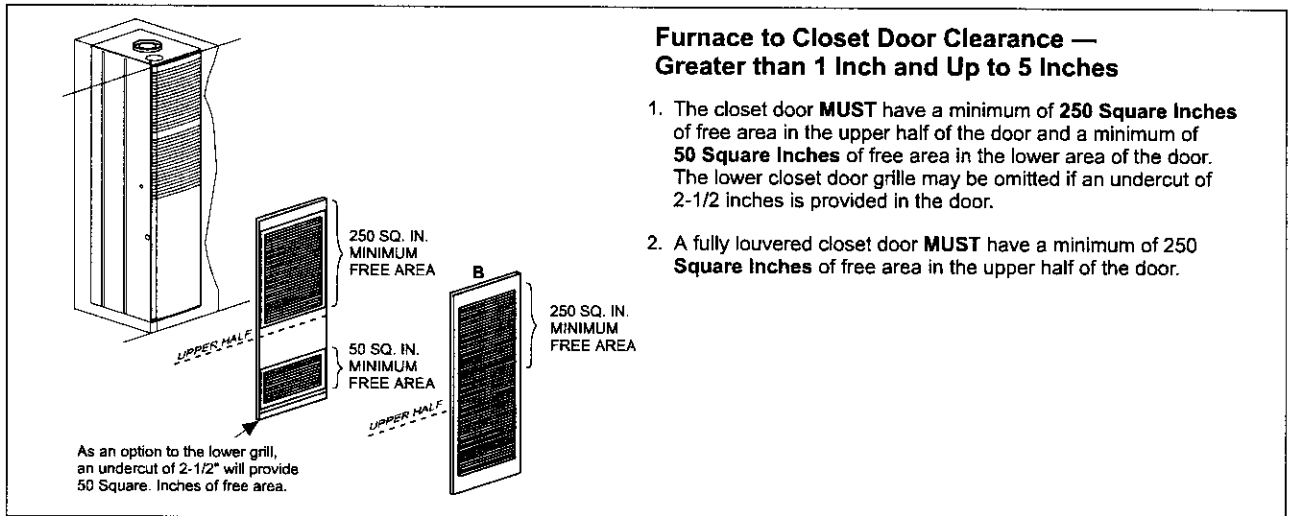


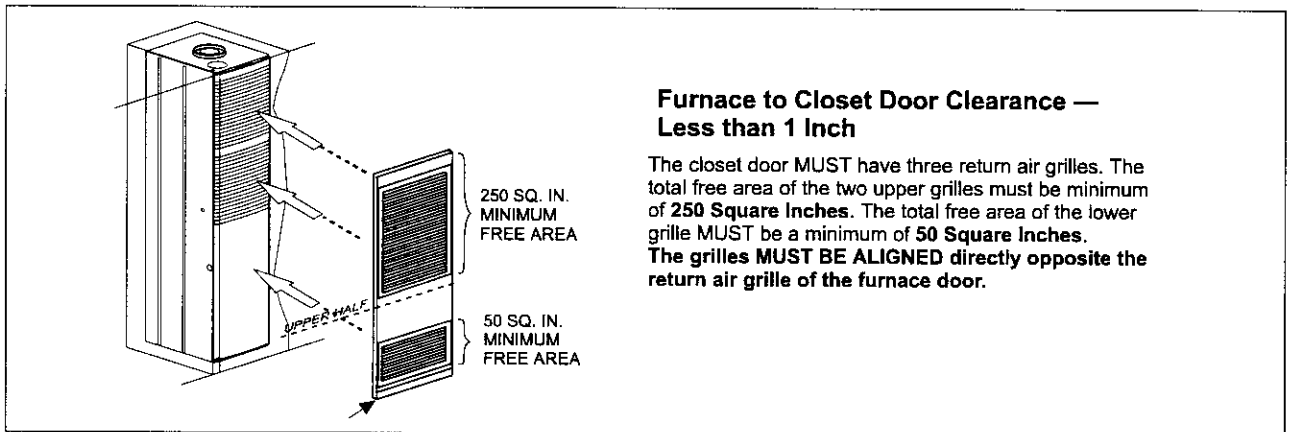
FIGURE 2 : Air Distribution Systems



**FIGURE 3 : Closet To Door Clearance - 6" or Greater**



**FIGURE 4 : Furnace To Closet Door Clearance - 1" To 6"**



**FIGURE 5 : Furnace To Closet Door Clearance - Less Than 1"**

## ROOF JACK

### **▲ WARNING**

*Failure to follow all venting instructions can result in fire, asphyxiation, or explosion.*

### **▲ CAUTION**

*Only use the appropriate roof jack. See Figures 6 & 7 for correct application.*

*Do not exceed the maximum height as determined from Figures 6 & 7. Installer should allow an additional 1-1/2" travel before the flue pipe assembly is fully extended against the built-in stop. This provides an additional safeguard against the flue assembly being pulled from the roof jack during transportation or other stress conditions.*

## EXISTING FURNACE REPLACEMENT

If this furnace replaces an existing furnace, do the following:

1. If a 2nd roof, roof cap or addition has been made to the existing roof of the home, remove the old roof jack completely! To avoid the possibility of an improperly installed pipe or gaps in the old roof jack, **INSTALL A NEW ROOF JACK**. Your ceiling and roof height will determine the correct roof jack to use. Refer to the vent selection table, of the furnace installation instructions.
2. After unpacking the roof jack, check the rain caps. Insure they are not damaged, tilted or crooked. Do not twist, crush or sit on the roof caps during installation. Damaged roof caps will cause improper furnace operation. The furnace will not heat properly and could result in explosion.
3. Before inserting the roof jack into the furnace top, inspect the furnace flue and combustion air opening for debris or insulation which might have fallen in during pre-installation steps. Do not proceed unless all debris has been cleaned out or removed.
4. After installing roof jack on furnace top collar, check to make sure there is no gap in back or side between the pipe collar and the furnace casing top.
5. Use only the pipes provided with the roof jack assembly. Do not add to or adapt other sheet metal pipes. Do not cut, insert or add other pipes to this assembly.
6. In no case should there be a gap between sections of the flue pipe or the combustion air pipe. If necessary to prevent excessive air leakage, the installer should seal joints in the combustion air tube with aluminum type or other suitable sealant.

## NEW HOME INSTALLATION

If this furnace is installed on a new home do the following:

1. Inspect the furnace top collars for signs of insulation or ceiling debris which might have fallen in during cutting of the ceiling and roof holes. Remove all debris before continuing.
2. After unpacking the roof jack, check the rain caps. Insure they are not damaged, tilted or crooked. Do not twist, crush or sit on the roof caps during installation. Damaged roof caps will cause improper furnace operation. The furnace will not heat properly and could result in explosion.
3. Before inserting the vent pipe into the furnace top, inspect the furnace flue and combustion air opening for debris or insulation which have fallen in during pre-installation steps. Do not proceed unless all debris have been cleaned out or removed.
4. After installing roof jack on furnace top collar, check to make sure there is no gap in back or side between the pipe collar and the furnace casing top. If necessary to prevent excessive air leakage, the installer should seal joints in the combustion air tube with aluminum type or other suitable sealant.

## INSTALLATION IN SNOW REGIONS

When the combustion air pipe inlet is covered or blocked with snow, the furnace will not operate properly due to the depleted combustion air supply.

Therefore, if the furnace will be located in regions where snow accumulation on the roof exceeds 7" or in H.U.D. Snow Load Zones, a roof jack extension (Part No. 7680B6541) is recommended.

## LOCATING AND CUTTING ROOF JACK OPENING

To facilitate the proper installation of the roof jack, it is very important that the roof jack opening in the ceiling and roof be on the same vertical center line as the furnace flue collar. See Figure 9.

Mark this location on ceiling and scribe a circle with a 5" radius (10" diameter) around this mark. Cut opening for roof jack through ceiling and roof. (If furnace was installed during construction, cover furnace and flue opening to prevent debris from entering flue when hole is cut for roof jack.)

## INSTALLING ROOF JACK IN ROOF

(See Figure 6 & 7 for Dimensional requirements.)

Insert roof jack into opening in the roof.

The roof jack should be secured to the furnace before roof flange (flashing) is secured to the roof. This will insure a better alignment of the flue pipe and furnace flue collar. Caulk around and under roof flange to provide a water tight seal, before securing roof jack flashing to roof.

SWIVEL FLASHING ADJUSTS FROM 0/12 TO 5/12 PITCH	SLANT FLASHING 3/12 PITCH	DGAH FURNACES	DGPH, DGPA, & DGAA FURNACES
		INSTALLATION DIMENSIONS	INSTALLATION DIMENSIONS
		"A" ADJUSTABLE HEIGHT	"B" ADJUSTABLE HEIGHT
4000-7101/C	4000-6101/A	70" to 79"	86" to 95"
4000-7121/C	4000-6121/A	75" to 86"	91" to 102"
4000-7141/C	4000-6141/A	83" to 104"	99" to 120"
4000-7151/C	4000-6151/A	90" to 116"	106" to 132"
4000-7171/C	4000-6171/A	127" to 157"	143" to 173"

<sup>1</sup> The 4084-7141 is dimensionally the same as 4000-7141/C and is available only in Canada.

<sup>2</sup> The 4084-7151 is dimensionally the same as 4000-7151/C and is available only in Canada.

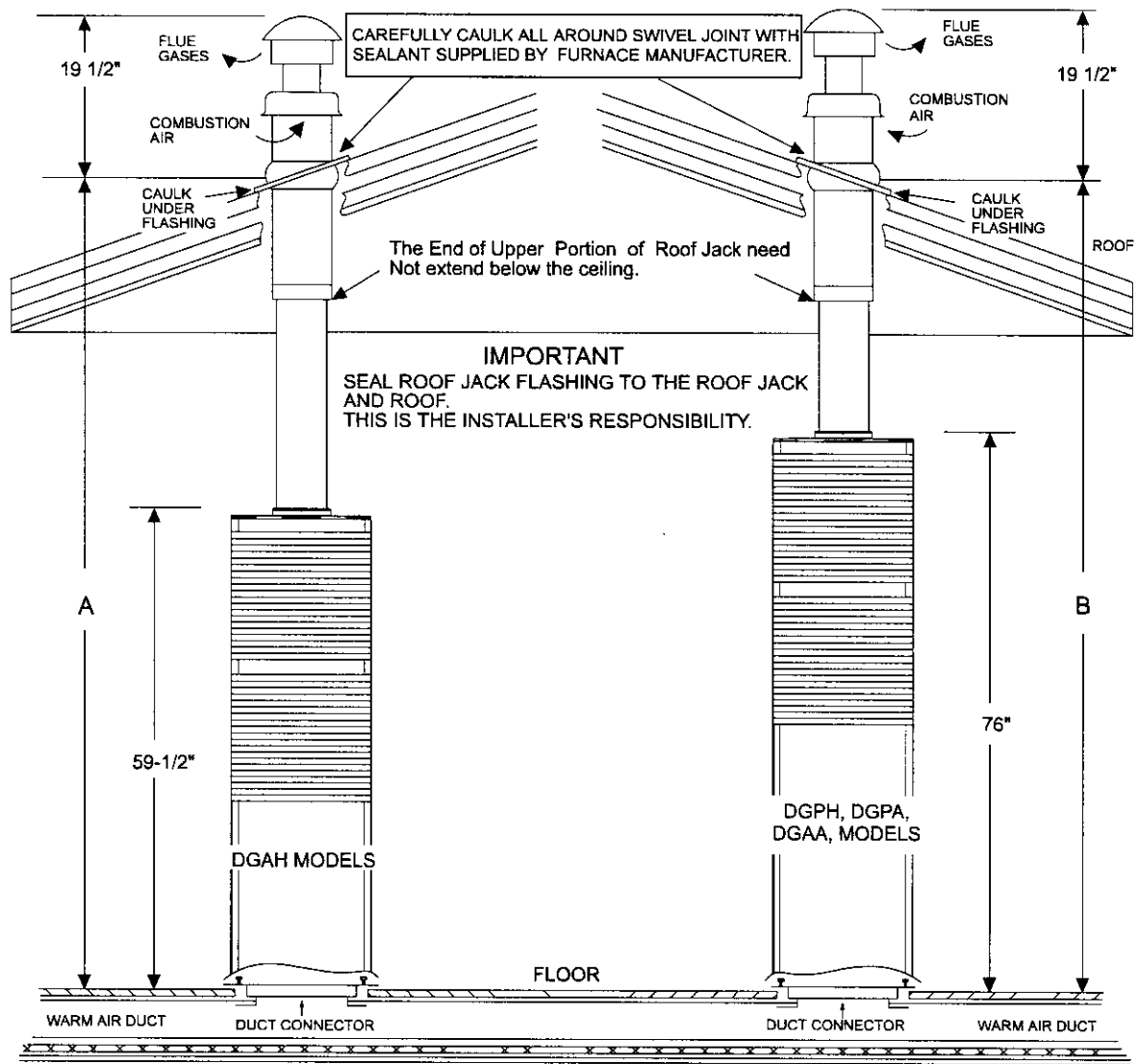


FIGURE 6 : Standard Roof Jack

SWIVEL FLASHING ADJUSTS FROM 0/12 TO 5/12 PITCH	SLANT FLASHING 3/12 PITCH	DGAH FURNACES	DGPH, DGPA, & DGAA FURNACES
		INSTALLATION DIMENSIONS	INSTALLATION DIMENSIONS
		"A" ADJUSTABLE HEIGHT	"B" ADJUSTABLE HEIGHT
4000-8161/C	4000-9161/A	85" to 101"	101" to 117"
4000-8181/C	4000-9181/A	99" to 129"	115" to 145"

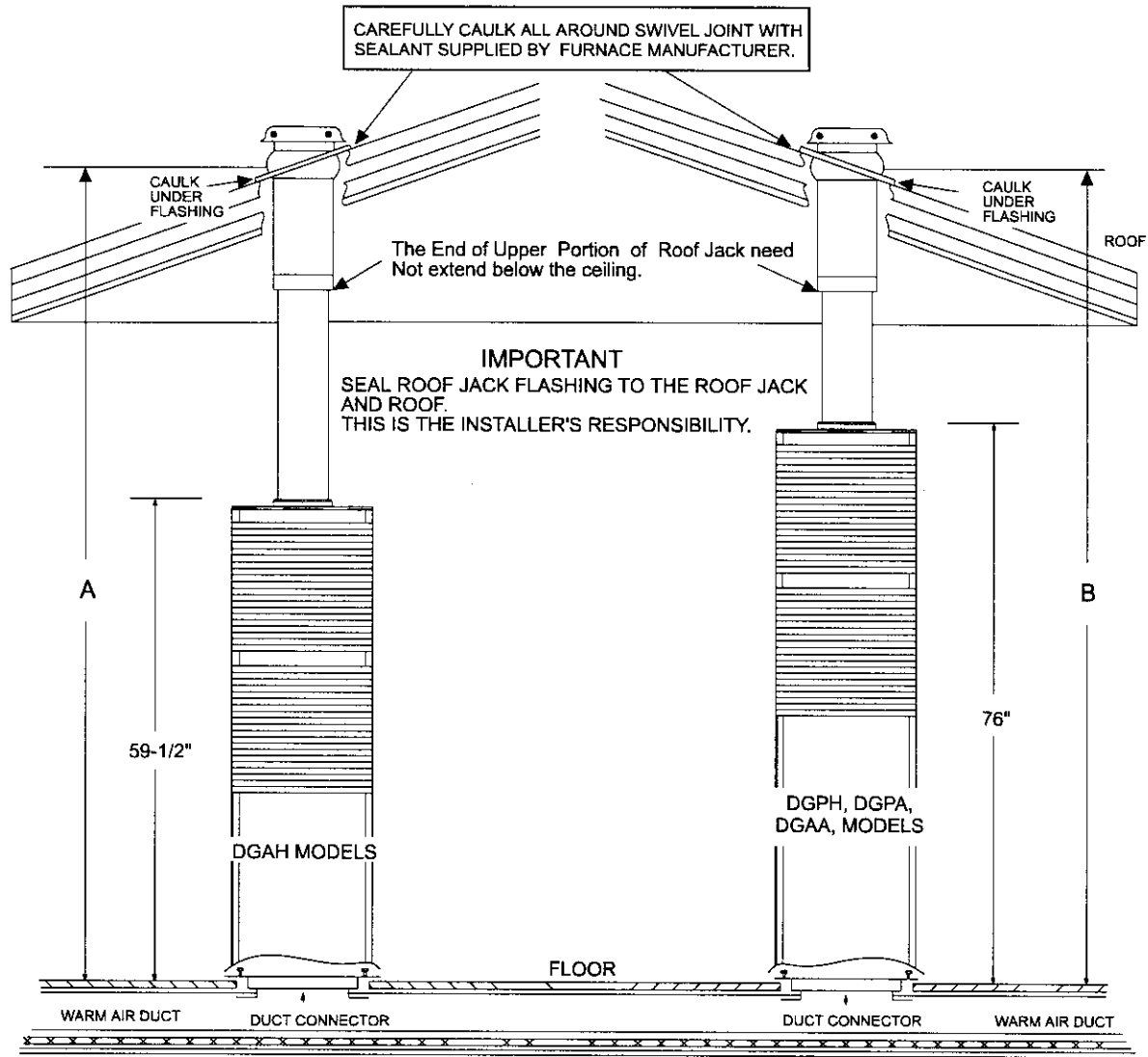


FIGURE 7 : Roof Jack With Removable Crowns



## DUCT CONNECTORS

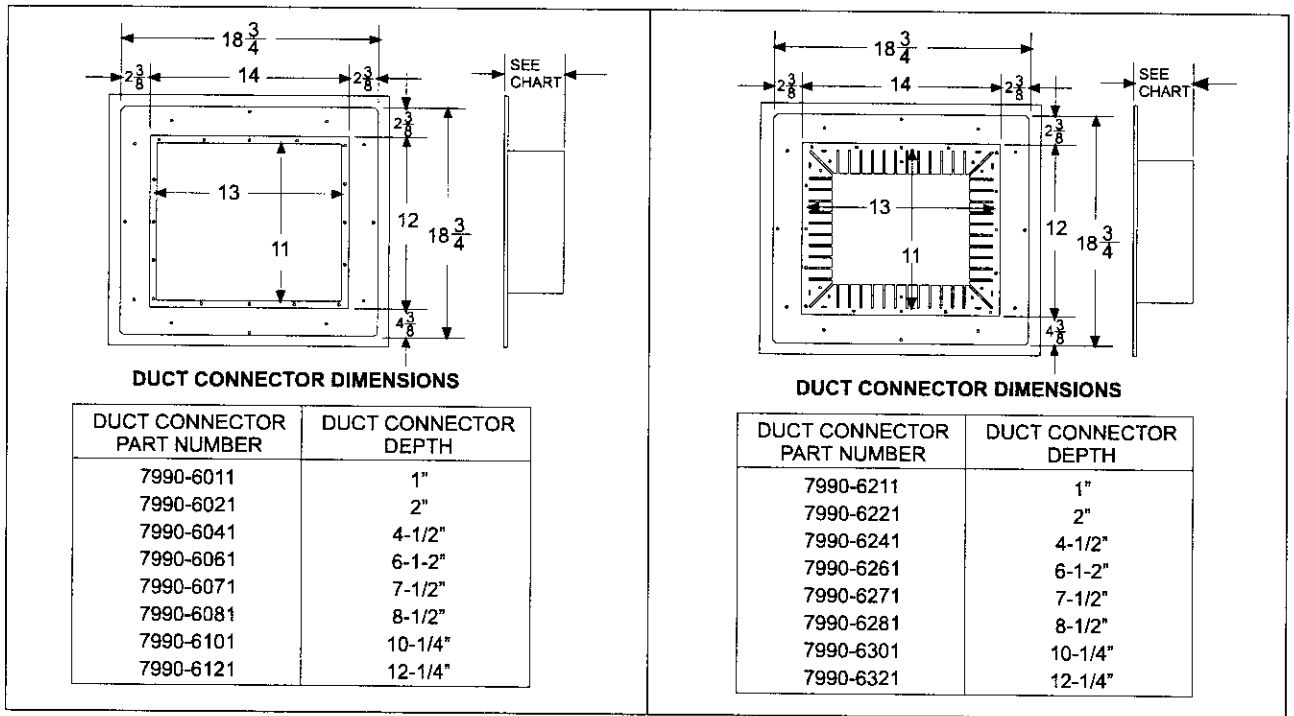


FIGURE 8 : Duct Connector Dimensions

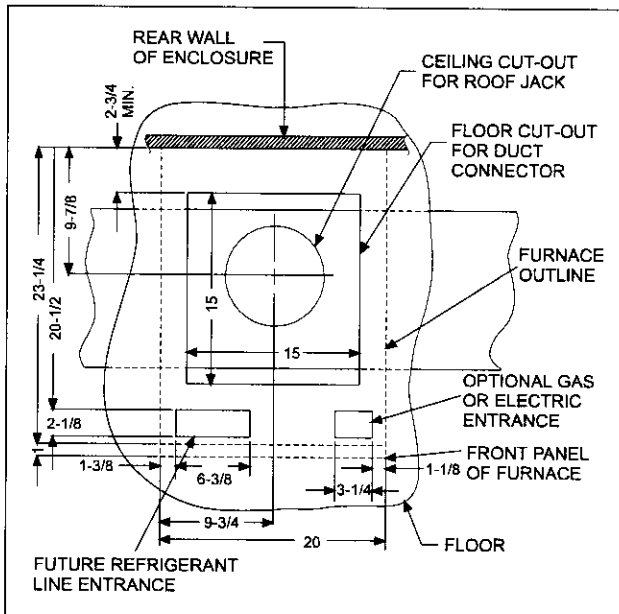


FIGURE 9 : Recommended Floor Cut-out

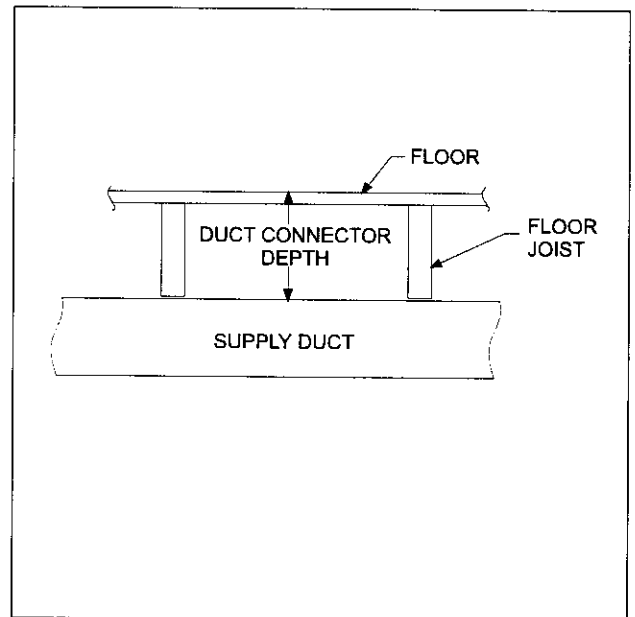
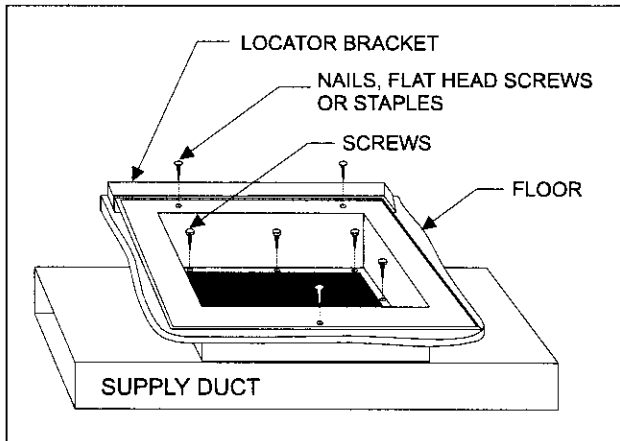


FIGURE 10 : Duct Connector Depth

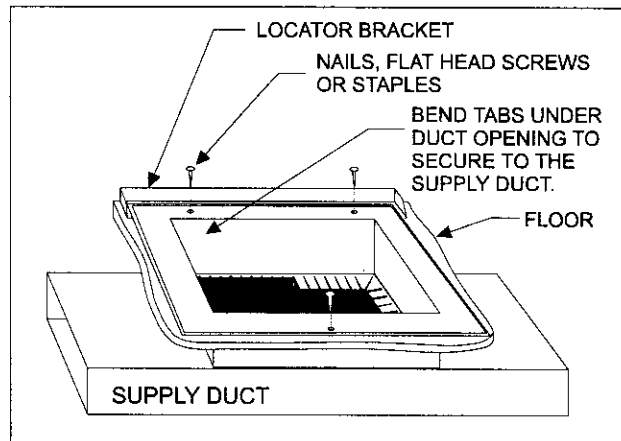


**FIGURE 11 : Duct Connector Screw Attachment**  
**INSTALLATION OF SCREW ATTACHMENT DUCT CONNECTOR**

1. Make floor cut out as shown in Figure 9.
2. Determine the depth of the floor cavity from the surface of the floor to the top of the supply air duct and select the appropriate duct connector from the chart.
3. Place locating bracket (supplied with the duct connector) to the back edge of the floor opening. See Figure 11.
4. Apply a water based duct sealant to the 1/2" supply duct attachment flange of the duct connector.
5. Determine which of the four positions the duct connector best centers over the supply duct and insert it through the floor cutout.
6. When properly aligned with the supply duct, secure the duct connector to the floor with nails, flat head screws or staples.
7. Use screws as required to secure the duct connector to the supply duct.
8. Cut out the opening to the supply duct. If sealant was not used, the installer should tape the mating flanges to provide a good air seal.

**NOTE:** Duct sealant and tape must be classified as meeting HUD Standard 3280.715, U.L. Standard 181A.

If tape is used to provide a better air seal, it should be a type approved by the applicable national or local codes.



**FIGURE 12 : Duct Connector Tab Attachment**  
**INSTALLATION OF TAB ATTACHMENT DUCT CONNECTORS**

1. Make floor cut out as shown in Figure 9.
2. Determine the depth of the floor cavity from the surface of the floor to the top of the supply air duct and select the appropriate duct connector from the chart.
3. Place locating bracket (supplied with the duct connector) to the rear of the floor area for the furnace. See Figure 12.
4. Determine which of the four positions the duct connector best centers over the supply duct and insert it through the floor cutout.
5. Mark cut-out location on the supply duct and remove the duct connector.
6. Cut out the opening to the supply duct.
7. Bend tabs down through and back up under the supply duct.
8. Secure the duct connector to the floor with nails, flat head screws or staples.

The duct connector is designed for use on ducts down to 12" in width. When using the connector on smaller width ducts, there will not be sufficient clearance to bend the tabs on two sides of the duct connector.

In such cases the tabs may be attached to the sides of the duct by using sheet metal screws or other suitable fasteners. Holes for sheet metal screws are provided in three (3) tabs on each side of the duct connector. If more than 3 tabs need to be used to provide a more secure and air tight connection, the remaining tabs can also be fastened to the duct with screws after drilling the required screw holes.

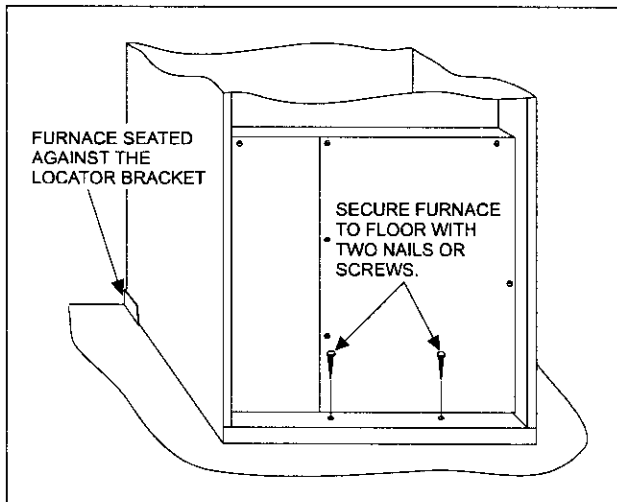


FIGURE 13 : Installation of Furnace

## INSTALLATION OF THE FURNACE

1. Remove the front panels and set the furnace onto the duct connector. Slide it back until the rear of the unit engages the locator bracket.
2. Secure the front of the furnace with two screws at the mounting holes provided.
3. Secure the top of the furnace to a structural member using screw through the strap at the back of the furnace. Strap may be moved to any of the holes located along the top back of the furnace. Installer may provide an equivalent method, such as screws through the casing side.

## CAUTION

*The inner flue pipe must be present.*

*It is mandatory that the combustion air pipe and flue pipe assembly be fully engaged. The combustion air pipe **MUST** be securely fastened to the furnace with a sheet metal screw in the hole provided.*

*Use a 1/2" blunt or sharp end sheet metal screw to fasten roof jack combustion air pipe to furnace combustion air collar. Screw hole is provided in the pipe and collar. Excessively long screws may extend to flue pipe and puncture it. Screws are not to exceed 1 1/2" in length.*

**NOTE:** Combustion air tube and flue pipe are part of the same assembly. Only the combustion air tube need be fastened to the furnace.

1. Check to be certain that the flue pipe and combustion air tube are present.
2. Pull the telescoping flue tube and combustion air tube assembly down from the roof jack. Slide the flue tube/ combustion air tube assembly down firmly over the furnace flue outlet and combustion air collar. Insure that the back, side and front of combustion air tube collar is fully engaged and is in contact with gasket. Fasten the combustion air tube to the furnace combustion air collar using a 1/2 inch sheet metal screw. (Screw hole provided in combustion air tube and furnace combustion air collar. See Figure 14.

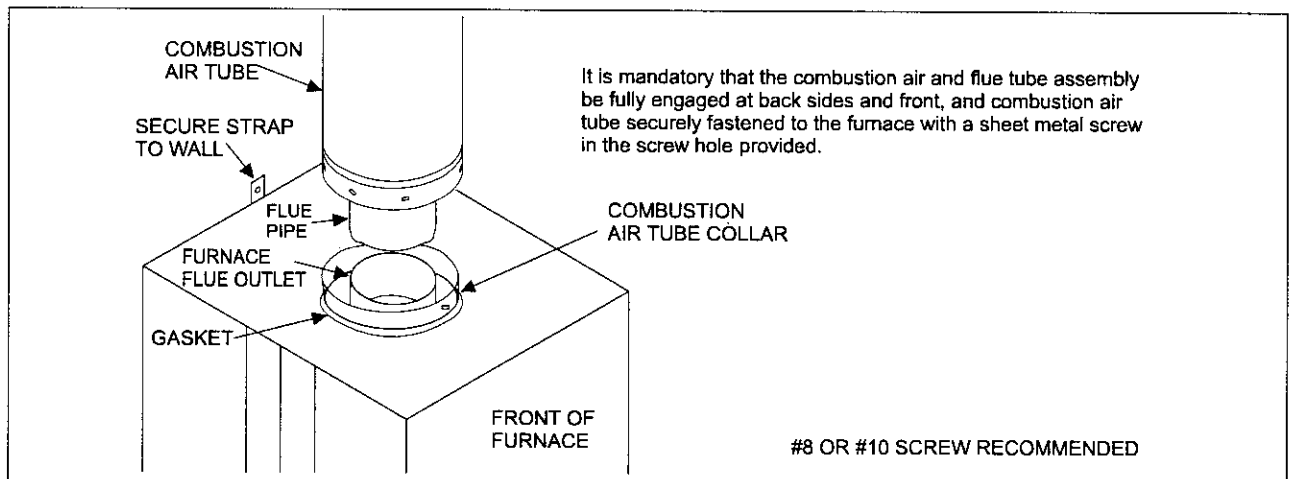


FIGURE 14 : Connecting Roof JACK to Furnace

**CEILING RINGS**

The ceiling ring is to meet fire stop requirements. Accessory Ceiling Ring (P/N 7660-2841) may be used, (See Figure 15) or the manufactured home manufacturer or the installer may use other approved methods to stop fire.

If required, three (3) sections of Accessory Ring may be used as shown in Figure 15 to provide closer clearance around roof jack.

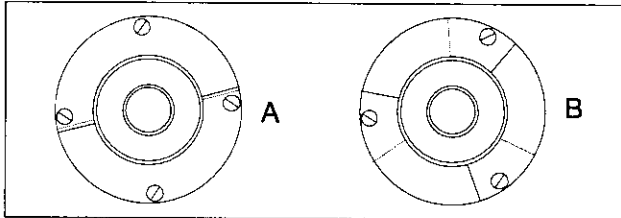


FIGURE 15 : Ceiling Rings

**ELECTRICAL WIRING**

**⚠ CAUTION**

*TO INSTALLER: Incoming power must be polarized. Observe color coding.*

**⚠ WARNING**

**SHOCK HAZARD - DISCONNECT ELECTRICAL POWER SUPPLY TO THE UNIT BEFORE SERVICING TO AVOID THE POSSIBILITY OF SHOCK INJURY OR DAMAGE TO THE EQUIPMENT.**

**CONNECT POWER SUPPLY WIRES**

1. Remove the field wiring cover.
2. Insert 115 volt wires through the large plastic bushing on the left side of the furnace (See Figure 16). If conduit is used it should be secured to the control box.
3. Connect the "hot" wire to the BLACK pigtail lead, and the "neutral" wire to the WHITE pigtail lead. Secure all connections with suitable wire nuts and wrap with electrical tape.
4. Connect the "ground" wire to the grounding screw.
5. Reinstall the control panel cover and secure mounting screw.

**CONNECT THERMOSTAT WIRES**

1. Insert 24 volt wires through the small plastic bushing just above the control panel.
2. Connect the thermostat wires to the furnace low voltage pigtails. See Figure 17 (heating only) and Figure 18 (heating and cooling).
3. Connect low-voltage circuit to the wall thermostat pig-tails.

**NOTE:** Five-conductor thermostat cable is recommended for all installations to allow easy installation of an air conditioning system at a later time.

**Eighteen gauge thermostat wire is highly recommended.** Smaller gauge thermostat wire may be used only if the guideline below is followed.

THERMOSTAT WIRE LENGTH (FURNACE TO THERMOSTAT)	THERMOSTAT WIRE GAUGE
0 - 45 feet	22
0 - 70 feet	20

Do not use thermostat wire smaller than 22 gauge. If thermostat wire smaller than 18 gauge is used, pay particular attention that the connections between the different wire sizes are tight.

Operational problems may be caused by loose connections or by the use of thermostat wire that is too small to carry the required load. Any such problems are the responsibility of the installer.

A separate 115 V.A.C. supply circuit must be used for the furnace. The circuit should be protected by a 15 amp fuse or circuit breaker.

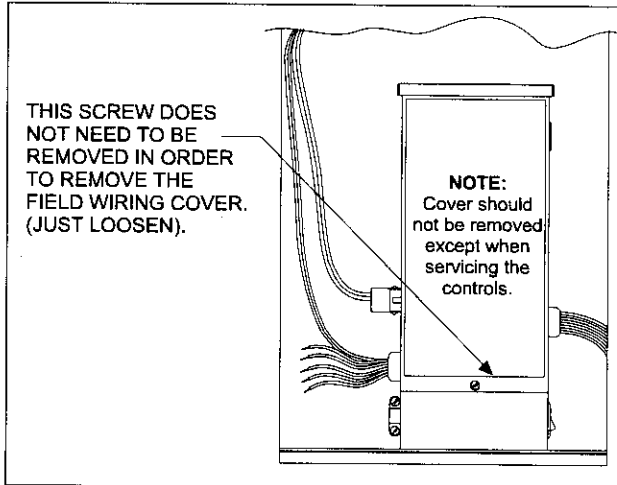


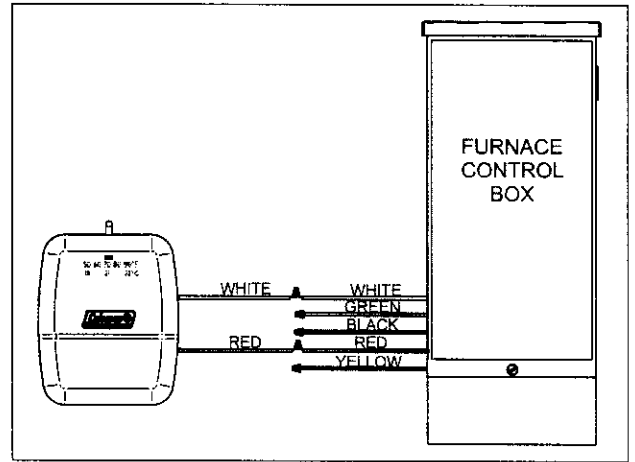
FIGURE 16 : Field Wiring

**WALL THERMOSTAT**

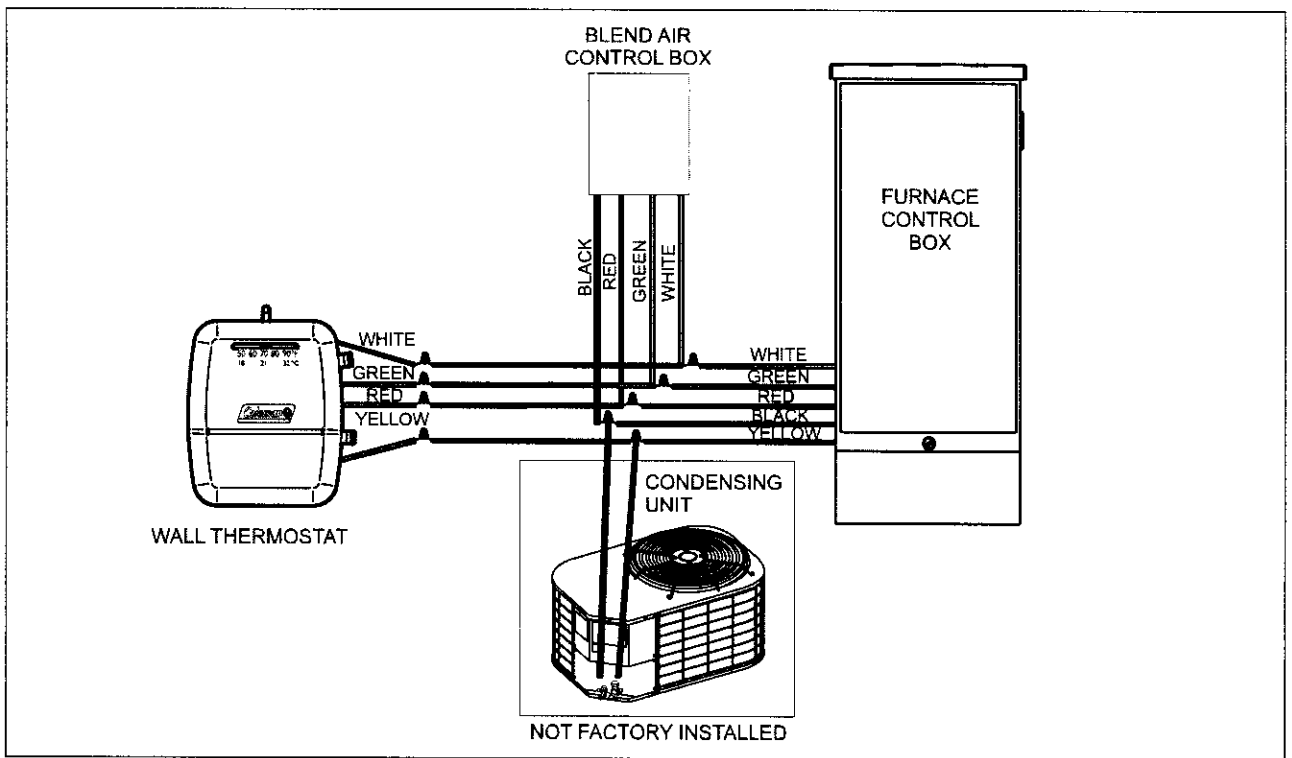
Avoid locations where the thermostat could be subject to drafts from outside, or exposed to direct light from lamps, sun, fireplaces, etc., or affected by air from a duct register blowing directly on the thermostat.

The wall thermostat should be located 52 to 66 inches above the floor. The preferred location is on an inside wall situated in an area with good air circulation, and where the temperature will be reasonably representative of other living areas the thermostat is controlling.

**NOTE:** In order to provide proper ventilation control when using DGPH model furnaces with Coleman Blend Air ventilation systems, it is required that a 4-wire wall thermostat and Blower Relay Kit 7900-7761 be installed.

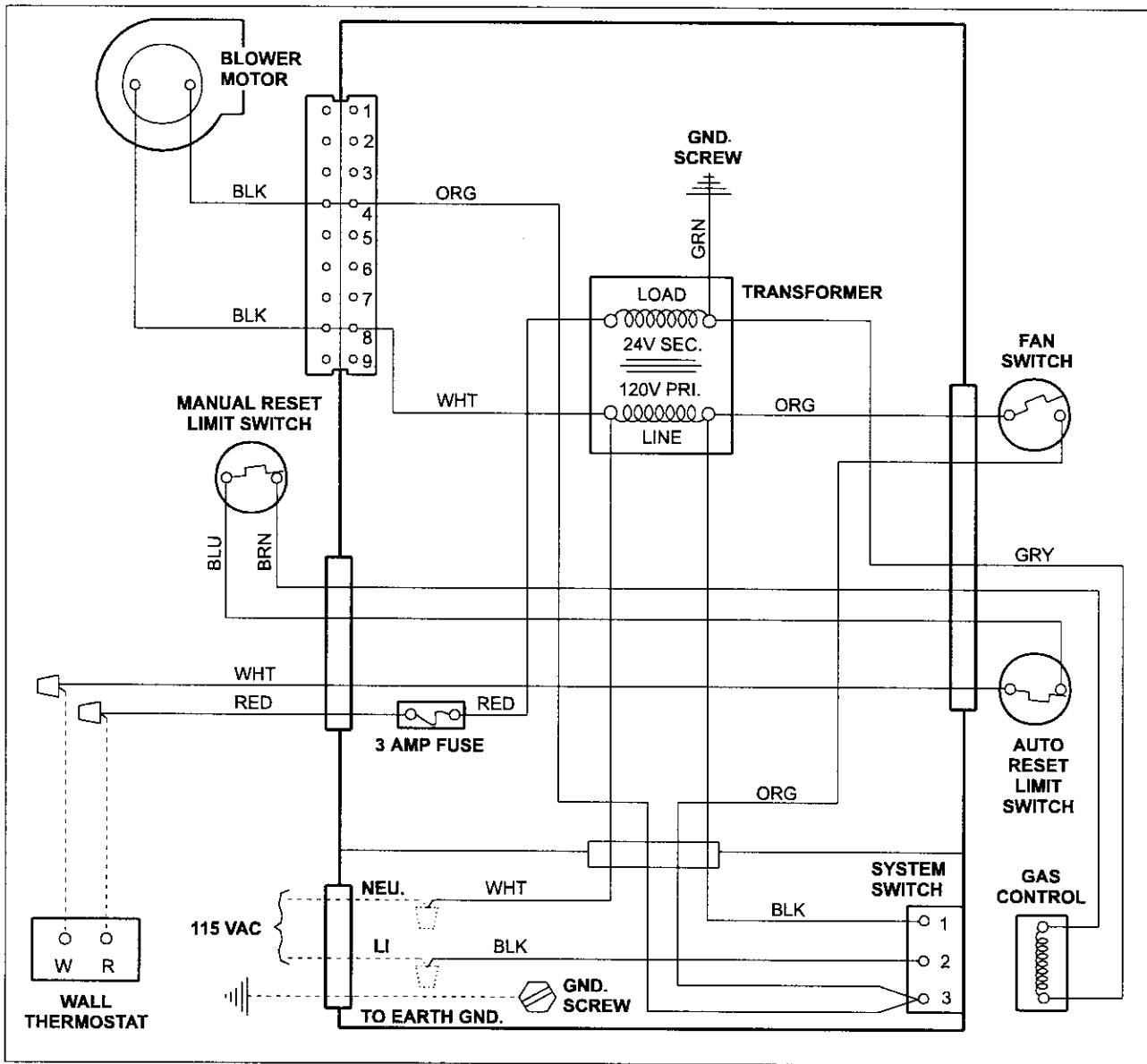


**FIGURE 17 : Wiring for Heat Only Thermostat**



**FIGURE 18 : Wiring for Heat-Cool Thermostat**

**WIRING DIAGRAMS**



**FIGURE 19 : Wiring Diagram for DGPH056, DGPH070, DGPH077**

**NOTE:** In order to provide proper ventilation control when using DGP model furnaces with Coleman Blend Air ventilation systems, it is required that a 4-wire wall thermostat and Blower Relay Kit 7900-7761 be installed.

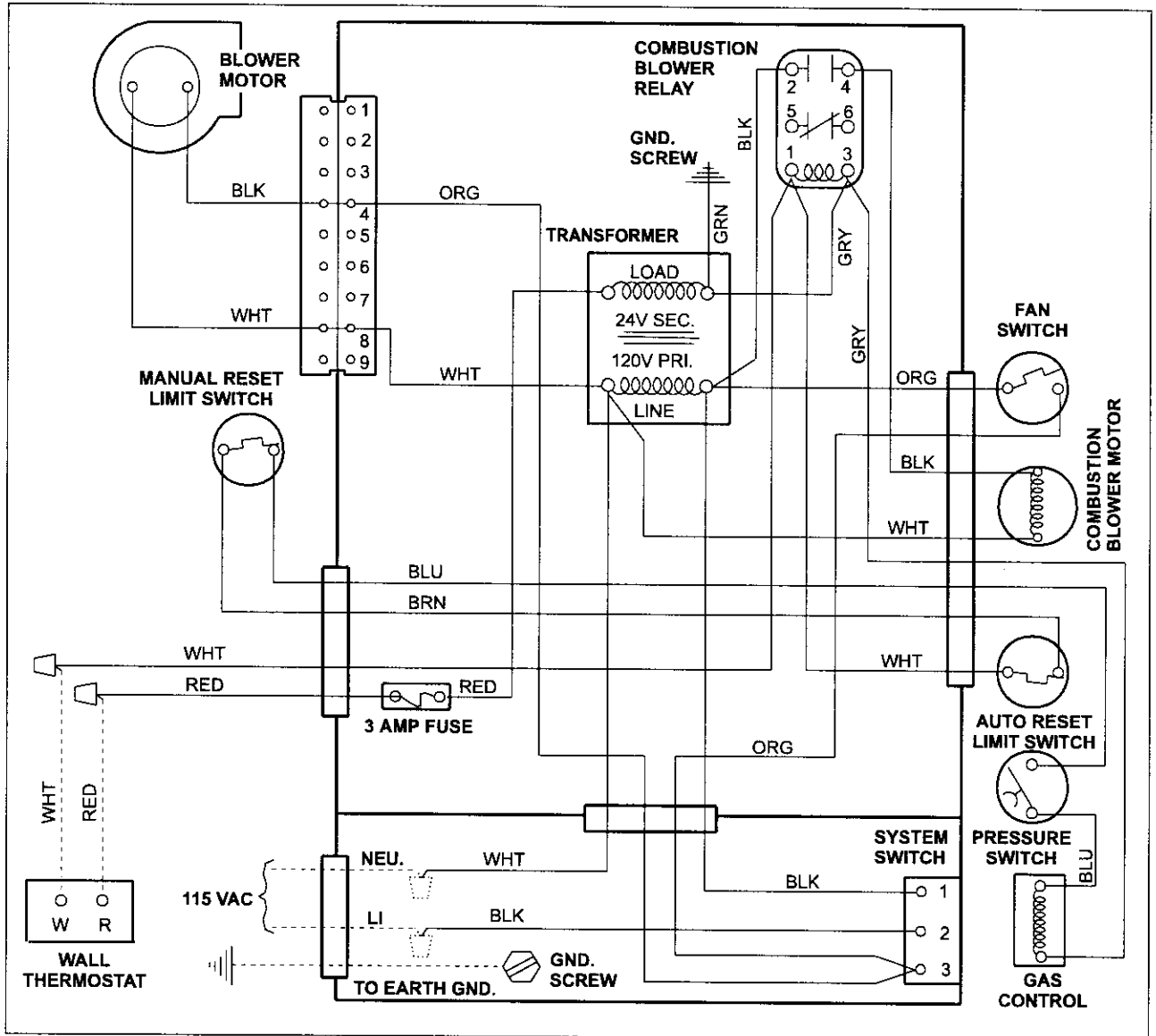


FIGURE 20 : Wiring Diagram for DGPH090

**NOTE:** In order to provide proper ventilation control when using DGPH model furnaces with Coleman Blend Air ventilation systems, it is required that a 4-wire wall thermostat and Blower Relay Kit 7900-7761 be installed.

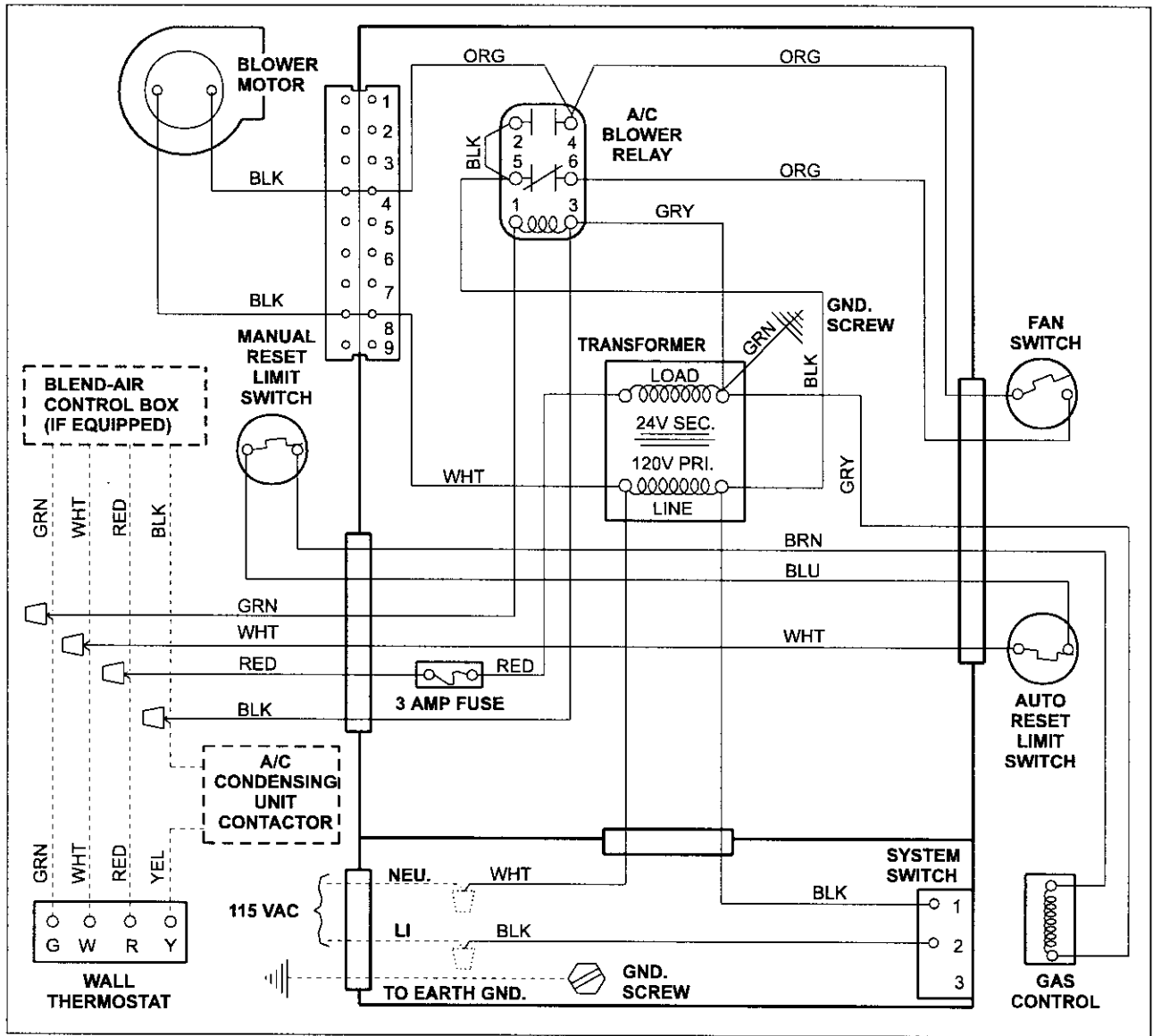


FIGURE 21 : Wiring Diagram for DGPA056, DGPA070, DGPA077



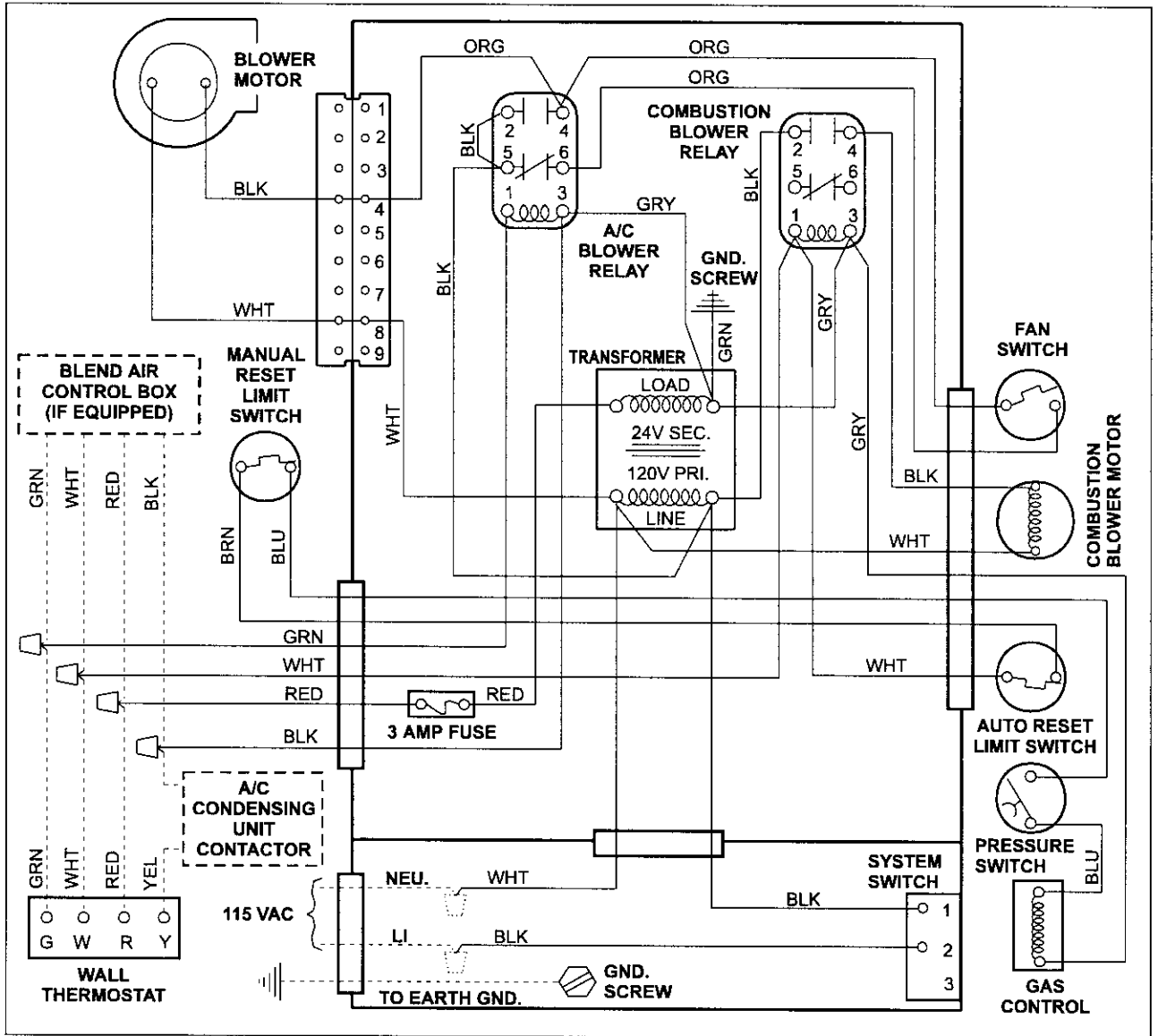


FIGURE 22 : Wiring Diagram for DGPA090



## GAS PIPING

### INSTALLATION AND CHECKING OF GAS LINE

Gas Supply piping must be sized in accordance with the recommendations contained in National Fuel Gas Code (ANSI-Z223.1, NFPA-54) unless local codes or regulations state otherwise.

Materials used and pipe sizing for U.S. manufactured homes must comply with requirements contained in Manufactured Homes A119.1, Recreational Vehicles A119.2 and H.U.D. Title 24, Section 3280.705 and any local or state codes.

**NOTE:** The gas line inlet on the gas valve is 1/2-14 N.P.T. The gas line may be installed through the furnace floor or furnace side to the gas valve.

#### **CAUTION**

*To install gas line and to connect it to the gas valve, care must be taken to hold gas valve firmly to prevent misalignment of the burner orifice, or to damage gas valve which could result in improper heating, explosion, fire or asphyxiation.*

*DO NOT USE EXCESSIVE PIPE SEALANT ON PIPE JOINTS. Pipe sealant, metal chips or other foreign material that could be deposited in the inlet of the gas valve, when gas pipe is installed or carried through the gas piping into the gas valve inlet after installation, may cause the gas valve to malfunction and could result in possible improper heating, explosion, fire or asphyxiation. Also, pipe sealant must be resistant to Propane gas.*

*Where regulations require, a main shut-off valve shall be installed externally of furnace casing. After piping has been installed, turn gas on and check all connections with a leak detector or soap solution.*

**Never use open flame to test for gas leaks as fire or explosion could occur.**

*Do not test the fuel system at more than 14" W.C. after furnace has been connected to fuel line. Such testing could void the warranty. Any test run above 14" W.C. may damage furnace control valve which could cause an explosion, fire or asphyxiation.*

#### **CAUTION**

*If the gas input to the furnace is too great because of excessive gas pressure, wrong size orifice, high altitude, etc., the burner flame will be sooty and may produce carbon monoxide, which could result in unsafe operation, explosion, and/or fire or asphyxiation.*

A dirt leg may be required by some local codes to trap moisture and contaminations.

For natural gas operation, the furnace is designed for 7" W.C. inlet gas pressure. Pressure to main burner is then reduced to 3 1/2" W.C.

For Propane gas operation, the furnace is designed for 11" W.C. inlet gas pressure. Pressure to main burner is then reduced to 10" W.C.

**IMPORTANT** - When converting gas valve from or to Propane gas, it will be necessary to change main burner orifice to prevent an underfired or overfired condition. See label inside lower furnace door for complete instructions.

#### **Pilot Adjustment**

On models equipped with standing pilot ignition, the pilot should be adjusted so that the flame is approximately 1" in height (500 BTU / hr.). This will allow proper burner ignition without excessive fuel usage. The pilot adjustment screw is located on the top of the gas valve.

#### **Observing Burner Operation**

1. Observe burner to make sure it ignites. Observe color of flame. On natural gas the flame will burn blue with appreciably yellow tips. On Propane gas a yellow flame may be expected. If flame is not the proper color call a qualified service technician for service.
2. Let furnace heat until blower cycles on.
3. Turn thermostat down.
4. Observe burner to make sure it shuts off.
5. Let the furnace cool and blower cycle off.

#### **WARNING**

*Should overheating occur, or the gas supply fail to shut off, shut off the manual gas valve to the furnace and allow burner to run until furnace cools down and blower shuts off before shutting off the electrical supply.*

If any abnormalities are observed when checking for correct operation, such as burner failing to ignite or to turn off, sooty flame, etc., call your nearest authorized service technician as shown in the Service Center List included in the home owner envelope with the furnace.

#### **If Furnace Fails to Operate Properly**

1. Check setting of thermostat - and position of HEAT/COOL switch if air conditioning is installed. If a set-back type thermostat is employed be sure that the thermostat is in the correct operating mode.
2. Check to see that electrical power is ON.
3. Check to see that the knob or switch on the gas control valve is in the full ON position.
4. Make sure filters are clean, return grilles are not obstructed, and supply registers are open.
5. Be sure that furnace flue piping is open and unobstructed.

If the cause for the failure to operate is not obvious, do not attempt to service the furnace yourself. Call a qualified service agency or your gas supplier.

## FINAL PROCEDURE

### INSTALL FURNACE DOORS

Install the lower door first by sliding the bottom of the door down until the tabs on the casing base engage the slots in the bottom door end cap. Then push the top of the lower door in until the door clips snap into place. Install the upper door in a similar manner, first engaging the slots in the top of the upper door on the tabs on the casing top. Then snap the bottom of the upper door into place against the casing.

### FINISH AND TRIM

Alcove and Closet Installations may now be finished and trimmed as necessary.

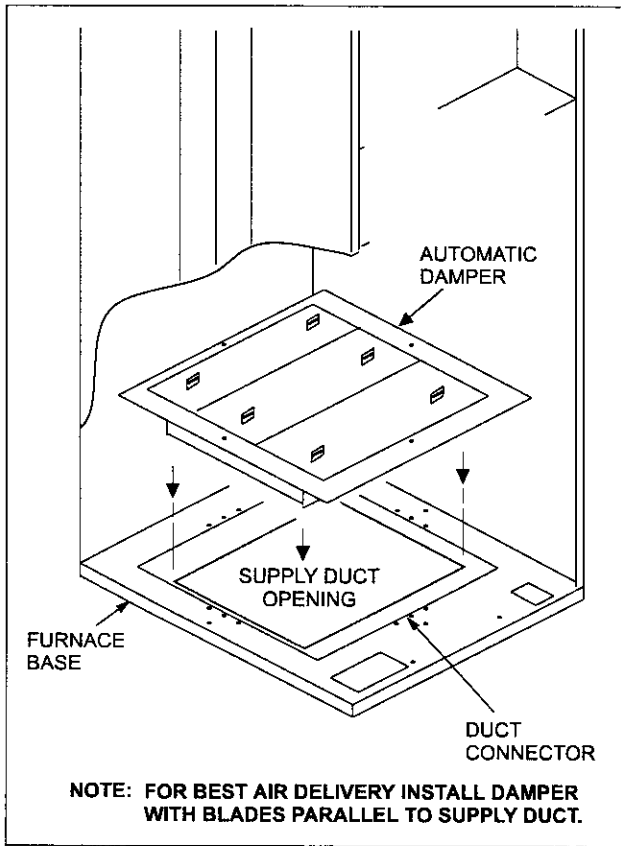


FIGURE 24 : Anti-Backflow Damper

## FURNACE AND AIR CONDITIONER INSTALLATIONS

If an air conditioner is installed which does not use the blower for air distribution and operates completely independent of the furnace, the thermostat system must have an interlock to prevent the furnace and air conditioner from operating at the same time. This interlock system usually contains a heat-cool switch which must be turned to either HEAT or COOL to activate either heating or cooling operation, or a positive OFF switch on the cooling thermostat.

When used in connection with a cooling unit the furnace shall be installed parallel with or on the upstream side of the cooling unit to avoid condensation in the heat exchanger.

For installations with a parallel flow arrangement, the furnace must be equipped with a damper to prevent cold air from being discharged up around the heat exchanger. Cold air causes condensation inside the exchanger and can cause it to rust out which can allow products of combustion to be circulated into the living area by the furnace blower resulting in possible asphyxiation. An air flow activated automatic damper, P/N 7900-6771, is available from furnace manufacturer. See Figure 24.

**NOTE:** See label on coil panel for conversion and lighting instructions. Obtain a temperature rise within the ranges specified on the name plate.

**HIGH ALTITUDE DERATION CHART**

<b>NATURAL GAS</b>												
Elevation	56,000 — Input			70,000 — Input			77,000 — Input			90,000 — Input		
	Orifice Dia.	Drill Size	Part #	Orifice Dia.	Drill Size	Part #	Orifice Dia.	Drill Size	Part #	Orifice Dia.	Drill Size	Part #
Sea Level	0.136	29	9951--1361	0.154	23	9951--1541	0.161	20	9951--1611	0.180	15	9951--1801
2,000	0.136	29	9951--1361	0.149	25	9951--1491	0.157	22	9951--1571	0.177	16	9951--1771
3,000	0.128	30	9951--1281	0.149	25	9951--1491	0.157	22	9951--1571	0.173	17	9951--1731
4,000	0.128	30	9951--1281	0.147	26	9951--1471	0.154	23	9951--1541	0.173	17	9951--1731
5,000	0.128	30	9951--1281	0.144	27	9951--1441	0.152	24	9951--1521	0.169	18	9951--1691
6,000	0.128	30	9951--1281	0.144	27	9951--1441	0.149	25	9951--1491	0.166	19	9951--1661
7,000	0.120	31	9951--1201	0.140	28	9951--1401	0.147	26	9951--1471	0.161	20	9951--1611
8,000	0.120	31	9951--1201	0.136	29	9951--1361	0.144	27	9951--1441	0.161	20	9951--1611
9,000	0.120	31	9951--1201	0.136	29	9951--1361	0.140	28	9951--1401	0.157	22	9951--1571
10,000	0.116	32	9951--1161	0.128	30	9951--1281	0.136	29	9951--1361	0.152	24	9951--1521

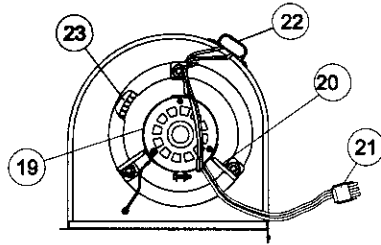
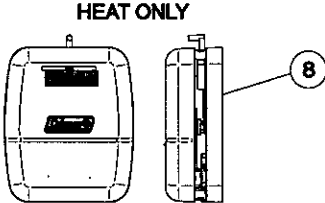
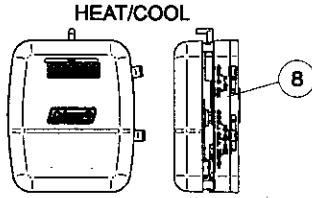
  

<b>PROPANE GAS</b>												
Elevation	56,000 — Input			70,000 — Input			77,000 — Input			90,000 — Input		
	Orifice Dia.	Drill Size	Part #	Orifice Dia.	Drill Size	Part #	Orifice Dia.	Drill Size	Part #	Orifice Dia.	Drill Size	Part #
Sea Level	0.082	45	9951--0821	0.093	42	9951--0931	0.098	40	9951--0981	0.106	36	9951--1061
2,000	0.081	46	9951--0811	0.093	42	9951--0931	0.096	41	9951--0961	0.104	37	9951--1041
3,000	0.078	47	9951--0781	0.089	43	9951--0891	0.093	42	9951--0931	0.101	38	9951--1011
4,000	0.078	47	9951--0781	0.089	43	9951--0891	0.093	42	9951--0931	0.101	38	9951--1011
5,000	0.078	47	9951--0781	0.089	43	9951--0891	0.093	42	9951--0931	0.099	39	9951--0991
6,000	0.076	48	9951--0761	0.086	44	9951--0861	0.089	43	9951--0891	0.098	40	9951--0981
7,000	0.076	48	9951--0761	0.086	44	9951--0861	0.089	43	9951--0891	0.096	41	9951--0961
8,000	0.073	49	9951--0731	0.082	45	9951--0821	0.086	44	9951--0861	0.096	41	9951--0961
9,000	0.073	49	9951--0731	0.081	46	9951--0811	0.086	44	9951--0861	0.093	42	9951--0931
10,000	0.070	50	9951--0731	0.078	47	9951--0781	0.082	45	9951--0821	0.089	43	9951--0891

Table shows 4% Input Reduction per 1,000 feet Elevation.  
Reference Source: NFPA No. 54, ANSI Z 223.1, National Fuel Gas Code.

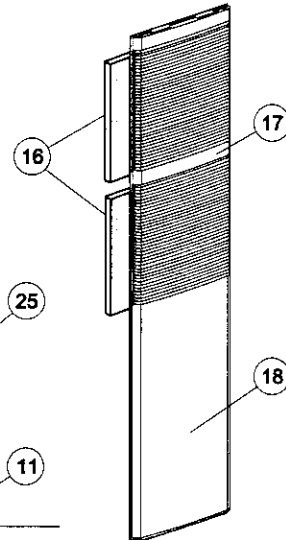
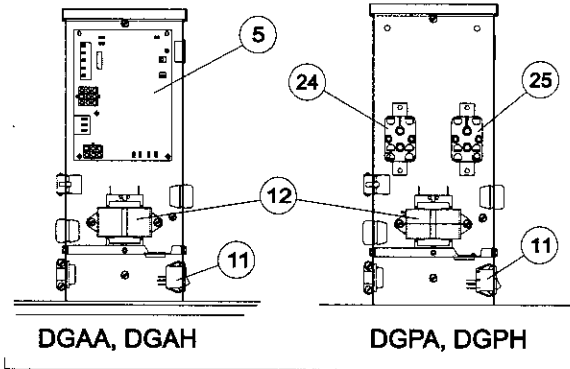
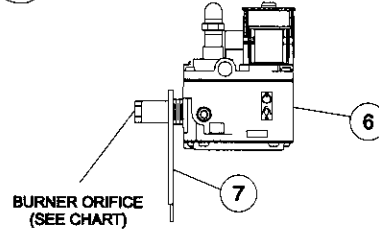
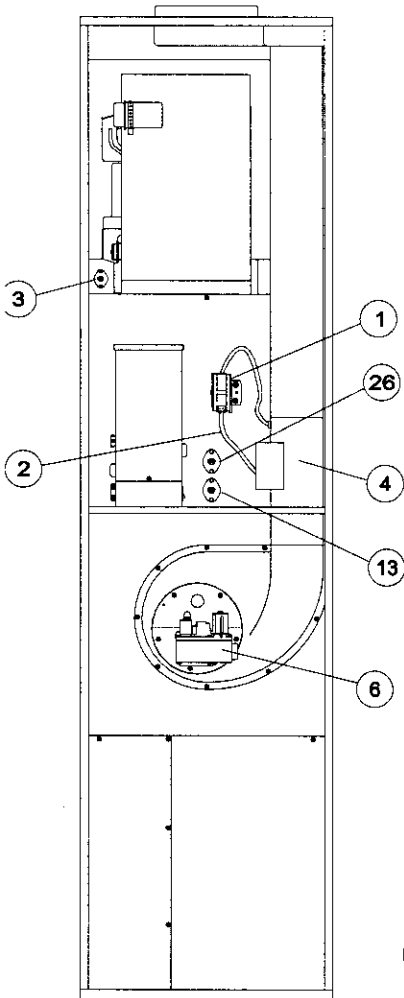
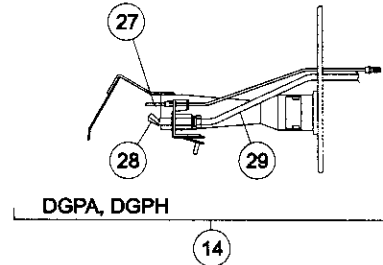
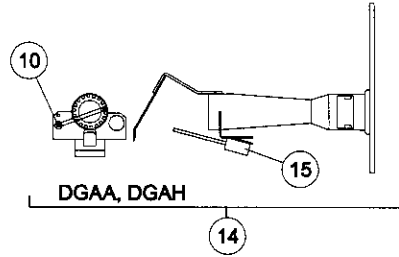
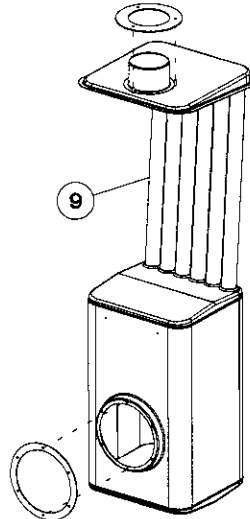
For Canadian high altitude (2000 - 4500 feet), reduce gas manifold pressure to 3.0" W.C. for natural gas, 9.0" W.C. for Propane gas.

**REPAIR PARTS LIST**



DGAA056BDTA DGPA056ABTA  
 DGAA070BDTA DGPA070ABTA  
 DGAA077BDTA DGPA077ABTA  
 DGAA090BDTA DGPA090ABTA

DGAH056BBSA DGPH056ABTA  
 DGAH077BBSA DGPH070ABTA  
 DGPH077ABTA  
 DGPH090ABTA



**CONTROL BOX DETAIL**

DGAA					
ITEM	DESCRIPTION	DGAA056BDTA	DGAA070BDTA	DGAA077BDTA	DGAA090BDTA
1	Switch, Pressure	024-27666-000	024-27666-000	024-27666-000	024-27666-000
2	Tubing Silicone (2' Req'd)	028-11957-000	028-11957-000	028-11957-000	028-11957-000
3	Limit Switch, Manual (Upper)	025-35358-000	025-35358-000	025-35358-000	025-35358-000
4	Assembly, Booster (w/Motor)	373-19801-820	373-19801-820	373-19801-820	373-19801-820
5	Control Board, Integrated	031-01932-000	031-01932-000	031-01932-000	031-01932-000
6	Valve, Gas	7990-328P	7990-328P	7990-328P	7990-328P
7	Bracket, Valve	073-19801-064	073-19801-064	073-19801-064	073-19801-064
8	Thermostat (Heat /Cool)	Accessory (See Page 6)			
9	Exchanger, Heat (w/Gaskets)	373-19804-651	373-19805-651	373-19806-651	373-19806-650
10	Sensor, Flame	025-35354-000	025-35354-000	025-35354-000	025-35354-000
11	Switch, System	7681-3301	7681-3301	7681-3301	7681-3301
12	Transformer (115-24V, 40 VA)	2940A3541	2940A3541	2940A3541	2940A3541
13	Switch, Limit	025-35380-000	025-35380-000	025-35381-000	025-35381-000
14	Burner Assembly, Auto Ignition (Includes items 10 & 15)	373-19801-403	373-19801-403	373-19801-403	373-19801-403
15	Ignitor, Hot Surface	1474-052P	1474-052P	1474-052P	1474-052P
16	Filter (2 Req'd) (16x20x1)	1214-2511	1214-2511	1214-2511	1214-2511
17	Panel, Door (Upper)	Accessory (See Page 6)			
18	Panel, Door (Lower, Tall)	373-19801-740	373-19801-740	373-19801-740	373-19801-740
19	Motor (See note 2)	1468-220P	1468-220P	1468-220P	1468-220P
20	Assembly, Motor Mount (See Note 3)	373-19806-100	373-19806-100	373-19806-100	373-19806-100
21	Plug, Connector	025-21192-000	025-21192-000	025-21192-000	025-21192-000
22	Capacitor, Run (See Note 3)	024-20063-000	024-20063-000	024-20063-000	024-20063-000
23	Wheel, Blower	1472-2761	1472-2761	1472-2761	1472-2761
24	Relay, Fan	---	---	---	---
25	Relay, Booster	---	---	---	---
26	Switch, Fan	---	---	---	---
27	Thermocouple	---	---	---	---
28	Burner, Pilot	---	---	---	---
29	Tube, Pilot	---	---	---	---
30*	Diagram, Wiring	035-15289-001	035-15289-001	035-15289-001	035-15289-001

## NOTE: \*Not Shown

New replacement parts shown in **bold** face type at the first printing of parts list dated 9/02.

Major components and suggested stocking items are shown with shaded item number.

"<" Across from row indicates a change in that row.

--- Not applicable to specified model.

- For Serial Numbers lower than 001207164- Replacement DGAA motors also require Motor Mount Assembly 373-19806-100 if replaced motor has integral, flex-arm motor mount.
- DGAA with 5-Ton Blowers are provided as an accessory item and are not standard equipment from the factory. See Page 6

<b>DGAH</b>			
<b>ITEM</b>	<b>DESCRIPTION</b>	<b>DGAH056BBSA</b>	<b>DGAH077BBSA</b>
1	Switch, Pressure	024-27666-000	024-27666-000
2	Tubing Silicone (2' Req'd)	028-11957-000	028-11957-000
3	Limit Switch, Manual (Upper)	025-35358-000	025-35358-000
4	Assembly, Booster (w/Motor)	373-19801-820	373-19801-820
5	Control Board, Integrated	031-01932-000	031-01932-000
6	Valve, Gas	7990-328P	7990-328P
7	Bracket, Valve	073-19801-064	073-19801-064
8	Thermostat (Heat /Cool)	Accessory (See Page 6)	
9	Exchanger, Heat (w/Gaskets)	373-19804-651	373-19806-651
10	Sensor, Flame	025-35354-000	025-35354-000
11	Switch, System	7681-3301	7681-3301
12	Transformer (115-24V, 40 VA)	2940A3541	2940A3541
13	Switch, Limit	025-35380-000	025-35381-000
14	Burner Assembly, Auto Ignition (Includes items 10 & 15)	373-19801-403	373-19801-403
15	Ignitor, Hot Surface	1474-052P	1474-052P
16	Filter (2 Req'd) (16x20x1)	1214-2511	1214-2511
17	Panel, Door (Upper)	Accessory (See Page 6)	
18	Panel, Door (Lower, Short)	373-19801-790	373-19801-790
19	Motor (See Note 3)	024-31948-000	024-31948-000
20	Assembly, Motor Mount	---	---
21	Plug, Connector	025-21192-000	025-21192-000
22	Capacitor, Run	---	---
23	Wheel, Blower	1472-2761	1472-2761
24	Relay, Fan	---	---
25	Relay, Booster	---	---
26	Switch, Fan	---	---
27	Thermocouple	---	---
28	Burner, Pilot	---	---
29	Tube, Pilot	---	---
30*	Diagram, Wiring	035-15289-001	035-15289-001

## NOTE: \*Not Shown

New replacement parts shown in **bold** face type at the first printing of parts list dated 9/02.

Major components and suggested stocking items are shown with shaded item number.

\*&lt; Across from row indicates a change in that row.

--- Not applicable to specified model.

3. DGAH with 5-Ton Blowers are provided as an accessory item and are not standard equipment from the factory. See page 6.



DGPA					
ITEM	DESCRIPTION	DGPA056ABTA	DGPA070ABTA	DGPA077ABTA	DGPA090ABTA
1	Switch, Pressure	---	---	---	024-27666-000
2	Tubing Silicone (2' Req'd)	---	---	---	028-11957-000
3	Limit Switch, Manual (Upper)	025-35358-000	025-35358-000	025-35358-000	025-35358-000
4	Assembly, Booster (w/Motor)	---	---	---	373-19801-820
5	Control Board, Integrated	---	---	---	---
6	Valve, Gas	7956-336P	7956-336P	7956-336P	7956-336P
7	Bracket, Valve	073-19801-064	073-19801-064	073-19801-064	073-19801-064
8	Thermostat (Heat /Cool)	Accessory (See Page 6)			
9	Exchanger, Heat (w/Gaskets)	373-19804-651	373-19805-651	373-19806-651	373-19806-650
10	Sensor, Flame	---	---	---	---
11	Switch, System	7681-3301	7681-3301	7681-3301	7681-3301
12	Transformer (115-24V, 40 VA)	2940A3541	2940A3541	2940A3541	2940A3541
13	Switch, Limit	025-35380-000	025-35380-000	025-35381-000	025-35381-000
14	Standing Pilot, Burner Assembly (Includes items 10 & 15)	373-19801-401	373-19801-401	373-19801-401	373-19801-402
15	Ignitor, Hot Surface	---	---	---	---
16	Filter (2 Req'd) (16x20x1)	1214-2511	1214-2511	1214-2511	1214-2511
17	Panel, Door (Upper)	Accessory (See Page 6)			
18	Panel, Door (Lower, Tall)	373-19801-740	373-19801-740	373-19801-740	373-19801-740
19	Motor (See Note 3)	024-31948-000	024-31948-000	024-31948-000	024-31949-000
20	Assembly, Motor Mount	---	---	---	---
21	Plug, Connector	025-21192-000	025-21192-000	025-21192-000	025-21192-000
22	Capacitor, Run	---	---	---	024-20045-000
23	Wheel, Blower	1472-2761	1472-2761	1472-2761	1472-2761
24	Relay, Fan	3110-3301	3110-3301	3110-3301	3110-3301
25	Relay, Booster	---	---	---	3110-3301
26	Switch, Fan	7975-3281	7975-3281	7975-3281	7975-3281
27	Thermocouple	7945-3481	7945-3481	7945-3481	7945-3481
28	Burner, Pilot	9880-0141	9880-0141	9880-0141	9880-0141
29	Tube, Pilot	029-22188-000	029-22188-000	029-22188-000	029-22188-000
30*	Diagram, Wiring	035-15287-001	035-15287-001	035-15287-001	035-15288-001

## NOTE: \*Not Shown

New replacement parts shown in **bold face type** at the first printing of parts list dated 9/02.

Major components and suggested stocking items are shown with shaded item number.

"<" Across from row indicates a change in that row.

--- Not applicable to specified model.

3. DGPA with 4 or 5-Ton Blowers are provided as an accessory item and are not standard equipment from the factory. See Page 6

DGPB					
ITEM	DESCRIPTION	DGPB056ABTA	DGPB070ABTA	DGPB077ABTA	DGPB090ABTA
1	Switch, Pressure	---	---	---	024-27666-000
2	Tubing Silicone (2' Req'd)	---	---	---	028-11957-000
3	Limit Switch, Manual (Upper)	025-35358-000	025-35358-000	025-35358-000	025-35358-000
4	Assembly, Booster (w/Motor)	---	---	---	373-19801-820
5	Control Board, Integrated	---	---	---	---
6	Valve, Gas	7956-336P	7956-336P	7956-336P	7956-336P
7	Bracket, Valve	073-19801-064	073-19801-064	073-19801-064	073-19801-064
8	Thermostat (Heat Only)	Accessory (See Page 6)			
9	Exchanger, Heat (w/Gaskets)	373-19804-651	373-19805-651	373-19806-651	373-19806-650
10	Sensor, Flame	---	---	---	---
11	Switch, System	7970-3331	7970-3331	7970-3331	7970-3331
12	Transformer (115-24V, 40 VA)	2940A3541	2940A3541	2940A3541	2940A3541
13	Switch, Limit	025-35380-000	025-35380-000	025-35381-000	025-35381-000
14	Standing Pilot, Burner Assembly (Includes items 10 & 15)	373-19801-401	373-19801-401	373-19801-401	373-19801-402
15	Ignitor, Hot Surface	---	---	---	---
16	Filter (2 Req'd) (16x20x1)	1214-2511	1214-2511	1214-2511	1214-2511
17	Panel, Door (Upper)	Accessory (See Page 6)			
18	Panel, Door (Lower, Tall)	373-19801-740	373-19801-740	373-19801-740	373-19801-740
19	Motor (See Note 3)	024-31948-000	024-31948-000	024-31948-000	024-31949-000
20	Assembly, Motor Mount	---	---	---	---
21	Plug, Connector	025-21192-000	025-21192-000	025-21192-000	025-21192-000
22	Capacitor, Run	---	---	---	024-20045-000
23	Wheel, Blower	1472-2761	1472-2761	1472-2761	1472-2761
24	Relay, Fan	---	---	---	---
25	Relay, Booster	---	---	---	3110-3301
26	Switch, Fan	7975-3281	7975-3281	7975-3281	7975-3281
27	Thermocouple	7945-3481	7945-3481	7945-3481	7945-3481
28	Burner, Pilot	9880-0141	9880-0141	9880-0141	9880-0141
29	Tube, Pilot	029-22188-000	029-22188-000	029-22188-000	029-22188-000
30	Diagram, Wiring	035-15285-001	035-15285-001	035-15285-001	035-15286-001

## NOTE: \*Not Shown

New replacement parts shown in bold face type at the first printing of parts list dated 9/02.

Major components and suggested stocking items are shown with shaded item number.

"<" Across from row indicates a change in that row.

--- Not applicable to specified model.

3. DGPB with 4 or 5-Ton Blowers are provided as an accessory item and are not standard equipment from the factory. See page 6.

<b>BURNER ORIFICE CHART (Normal Altitude Only *)</b>				
<b>MODEL</b>	<b>056</b>	<b>070</b>	<b>077</b>	<b>090</b>
NATURAL GAS	9951-1361	9951-1541	9951-1611	9951-1801
LP GAS	9951-0821	9951-0931	9951-0981	9951-1061

## NOTES

4. Contact Customer Service for installations at altitudes over 2000 feet above sea level.  
 \*< Across from row indicates a change in that row.

<b>ACCESSORY PARTS LIST</b>					
	<b>DESCRIPTION</b>	<b>DGAA</b>	<b>DGAH</b>	<b>DGPA</b>	<b>DGPH</b>
	Thermostat (Heat/Cool)	025-38251-000	025-38251-000	025-38251-000	---
	Thermostat (Heat Only)	---	---	---	025-38252-000
	Door Panel (Upper)	373-19802-010	373-19802-010	373-19802-010	373-19802-010
4-Ton Blower Ass'y 7900-7741/A	Motor	---	---	1468-220	1468-220
	Run Capacitor (7.5 MFD)	---	---	024-32020-000	024-32020-000
	Motor Mount	---	---	373-19806-100	373-19806-100
	Blower Wheel	---	---	1472-2761	1472-2761
5-Ton Blower Ass'y 7900-7751	Motor	024-31975-000	024-31975-000	024-31975-000	024-31975-000
	Run Capacitor (20 MFD)	024-20051-000	024-20051-000	024-20051-000	024-20051-000
	Motor Mount	373-19802-930	373-19802-930	373-19802-930	373-19802-930
	Blower Wheel	1472-2761	1472-2761	1472-2761	1472-2761

# NOTES

Subject to change without notice. Printed in U.S.A.  
Copyright © by York International Corp. 2002. All rights reserved.

035-16328-002 Rev. C (0902)  
Supersedes: 0035-16328-002 Rev. B (1001)

---

**Unitary  
Products  
Group**

**P.O.  
Box  
19014**

**Wichita  
KS  
67204-9014**