

HUSSMANN®/Chino FMSS Case-front Self Service	Installation & Operation Manual Rev.0301
--	--

HUSSMANN® FMSS

Case-front Self Service Refrigerated Merchandiser



p/n IGSS-FMSS-0301

INSTALLATION & OPERATION GUIDE

General Instructions

Table of Contents

General Instructions	2
Cut & Plan Views	3
Installation (cont.)	4
LEVELING	4
Plumbing	5
WASTE OUTLET AND P-TRAP	5
JOINT TRIM	5
Refrigeration	6
T-STAT LOCATION	6
Electrical	7
WIRING COLOR CODE	7
Wiring Diagram	8
User Information	13
STOCKING	13
CASE CLEANING	13
Maintenance	14
ELECTRICAL PRECAUTIONS	14
REPLACING FLUORESCENT LAMPS	14
PLEXIGLASS & ACRYLIC CARE	14
TIPS & TROUBLESHOOTING	14
Specifications	15
Appendices	16
APPENDIX A. — Temperature Guidelines	16
APPENDIX B. — Application Recommendations	16
APPENDIX C. — Field Recommendations	16
APPENDIX D. — Recommendations to user	17

THIS BOOKLET CONTAINS INFORMATION ON:

FMSS-Remote

The FMSS is a single-deck, refrigerated, self-service merchandiser, which offers additional related display when positioned in front of a “Parent” service case.

SHIPPING DAMAGE

All equipment should be thoroughly examined for shipping damage before and during unloading.

This equipment has been carefully inspected at our factory and the carrier has assumed responsibility for safe arrival. If damaged, either apparent or concealed, claim must be made to the carrier.

APPARENT LOSS OR DAMAGE

If there is an *obvious loss or damage*, it must be noted on the freight bill or express receipt and signed by the carrier’s agent; otherwise, carrier may refuse claim. The carrier will supply necessary claim forms.

CONCEALED LOSS OR DAMAGE

When loss or damage is *not apparent until after equipment is uncrated*, a claim for concealed damage is made. Make request in writing to carrier for inspection within 15 days, and retain all packaging. The carrier will supply inspection report and required claim forms.

SHORTAGES

Check your shipment for any possible shortages of material. If a shortage should exist and is found to be the responsibility of Hussmann Chino, *notify Hussmann Chino*. If such a shortage involves the carrier, *notify the carrier immediately*, and request an inspection. Hussmann Chino will acknowledge shortages within ten days from receipt of equipment.

HUSSMANN CHINO PRODUCT CONTROL

The serial number and shipping date of all equipment has been recorded in Hussmann’s files for warranty and replacement part purposes. All correspondence pertaining to warranty or parts ordering must include the serial number of each piece of equipment involved, in order to provide the customer with the correct parts.

The Hussmann warranty is printed on the back of this guide.

Keep this booklet with the case at all times for future reference.

HUSSMANN®/Chino

A publication of
Hussmann® Chino
13770 Ramona Avenue • Chino, California 91710
(909) 628-8942 FAX
(909) 590-4910
(800) 395-9229

Cut & Plan Views

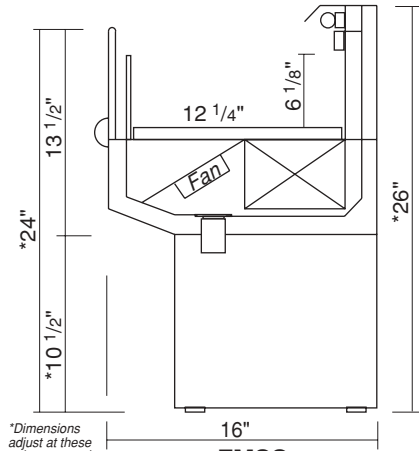

*Dimensions adjust at these points to match service case height

FMSS Remote
Self-Service Shown with Optional Special Height
Scale = 1"

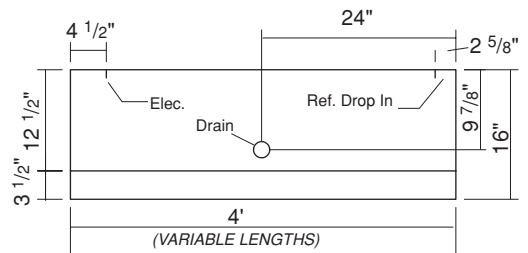

FMSS Plan View
Scale = 1/2"

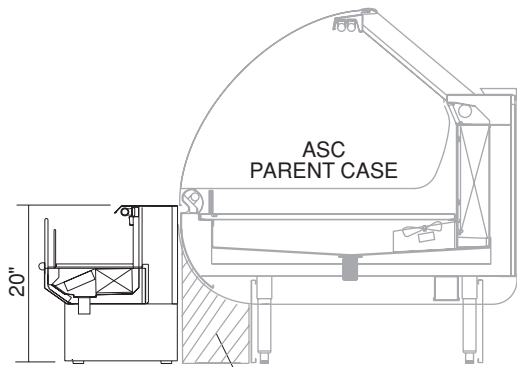

FMSS
Height Modified to match the ASC case

FMSS

Front-Mount Self-Service case. Can be ordered to mount in front of ANY service case. Base height can be modified to match any service case bumper height.

Installation (cont.)

LOCATION

The refrigerated merchandisers have been designed for use only in air conditioned stores where temperature and humidity are maintained at or below 75°F and 55% relative humidity. **DO NOT** allow air conditioning, electric fans, ovens, open doors or windows (etc.) to create air currents around the merchandiser, as this will impair its correct operation.

Product temperature should always be maintained at a constant and proper temperature. This means that from the time the product is received, through storage, preparation and display, the temperature of the product must be controlled to maximize life of the product.

UNCRATING THE STAND

Place the fixture as close to its permanent position as possible. Remove the top of the crate. Detach the walls from each other and remove from the skid. Unbolt the case from the skid. The fixture can now be lifted off the crate skid. **Lift only at base of stand!**

EXTERIOR LOADING

These models have **not** been structurally designed to support excessive external loading. **Do not walk on their tops;** This could cause serious personal injury and damage to the fixture.

SETTING AND JOINING

The case that the FMSS connects to (the *parent* case) through the rear of the case must be leveled and set prior to installing the FMSS. The sectional construction of these models enable them to be joined in line - to give the effect of one continuous display. A joint Trim Kit is supplied with each case line to cosmetically "mask" the sectional joints. See the "Finishing Touches" section for more information on joint trim.

LEVELING

IMPORTANT! It is imperative that cases be leveled from front to back and side to side prior to joining. A level case is necessary to insure proper operation, water drainage, glass alignment, and operation of the hinges supporting the glass. Leveling the case correctly will solve most hinge operation problems.

NOTE: A. To avoid removing concrete flooring, begin lineup leveling from the highest point of the store floor.

B. When wedges are involved in a lineup, set them first.

All cases were leveled and joined prior to shipment to insure the closest possible fit when cases are joined in the field. When joining, use a carpenter's level and shim legs accordingly. Case must be raised correctly, under legs where support is best, to prevent damage to case.

1. Check level of floor where cases are to be set.

Determine the highest point of the floor; cases will be set off this point.

2. Level and set the first case, carefully guiding the electrical, refrigeration and drain lines through the parent case. Case must be raised under legs where support is best to prevent damage to case. Internal bracing may be removed at this time.
3. Set second case as close as possible to the first case carefully guiding its electrical, refrigeration and drain lines through the parent case, and level case to the first using the instructions in step one.
4. Apply masking tape 1/8" in from end of case on inside and outside rear mullion on both cases to be joined.
5. Apply liberal bead of case joint sealant (butyl) to dotted area shown in (Fig.2, #1) of first case. Apply heavy amount to cover entire shaded area.

DO NOT USE PERMAGUM!

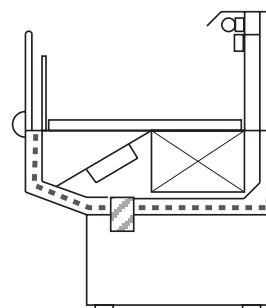

Fig. 2, #1



It is the contractor's responsibility to install case(s) according to local construction and health codes.

6. Slide second case up to first case snugly. Then level second case to the first case so glass front, bumper and top are flush.



Do not use the top bracket on the rear mullion to pull the cases together.

Installation (cont.)

7. To compress silicone at joint, use two Jurgenson wood clamps. Make sure case is level from front to back and side to side on inside bulkheads at joint.
8. Attach sections together with the two 3/8" bolts provided, below the deck at the mullion towards the rear of the FMSS. Remove clamps.
9. Apply bead of silicone to top of bulkheads and slip on stainless steel bulkhead cap. Also apply silicone to seam between overhead light tubes.
10. **VERY IMPORTANT!** Apply liberal amounts of black silicone to fill all voids down to bulkhead.

(apply additional silicone if necessary). Remove tape applied on line #3.

JOINT TRIM

After cases have been leveled and joined, and refrigeration, electrical, and wasted piping work completed, install the splashguards. Fasten along the top edge, or center, with #10 X 3/3" sheet metal screws.

Do Not Seal Joint Trim To Floor!



Proper case-joint sealing is extremely important to prevent water leaks!

IMPORTANT INFORMATION

11. Use finger to smooth silicone as thin as possible at masking tape on inside and outside of rear mullion

Plumbing**WASTE OUTLET AND P-TRAP**

The waste outlet is located at the left hand end of these fixtures allowing drip piping to be run under the fixture lengthwise.

A 1" P-trap and threaded adapter are supplied with each fixture. The P-trap must be installed to prevent air leakage and insect entrance into the fixture.

INSTALLING CONDENSATE DRAIN

Poorly or improperly installed condensate drains can seriously interfere with the operation of this refrigerator, and result in costly maintenance and product losses. Please follow the recommendations listed below when installing condensate drains to insure a proper installation:

1. Never use pipe for condensate drains smaller than the nominal diameter of the pipe or P-trap supplied with the case.
2. When connecting condensate drains, the P-trap must be used as part of the condensate drain to prevent air leakage or insect entrance. Store plumbing system floor drains should be at least 14" off the center of the case to allow use of the P-trap pipe

section. Never use two water seals in series in any one line. Double P-traps in series will cause a lock and prevent draining.

3. Always provide as much down hill slope ("fall") as possible; 1/8" per foot is the preferred minimum. PVC pipe, when used, must be supported to maintain the 1/8" pitch and to prevent warping.
4. Avoid long runs of condensate drains. Long runs make it impossible to provide the "fall" necessary for good drainage.
5. Provide a suitable air break between the flood rim of the floor drain and outlet of condensate drain. 1" is ideal.
6. Prevent condensate drains from freezing:
 - a. Do not install condensate drains in contact with non-insulated suction lines. Suction lines should be insulated with a nonabsorbent insulation material such as Armstrong's Armaflex.
 - b. Where condensate drains are located in dead air spaces (between refrigerators or between a refrigerator and a wall), provide means to prevent freezing. The water seal should be insulated to prevent condensation.

Refrigeration

REFRIGERANT TYPE

The standard refrigerant will be R-404 unless otherwise specified on the customer order. Check the serial plate on the case for information.

Piping for more than one case on a condensing unit is run underground with either common suction and liquid lines from the machine room or individual suction and liquid lines joined together in the machine room.

REFRIGERATION LINES

LIQUID	SUCTION
3/8" O.D.	5/8" O.D.

NOTE: The standard coil is piped at 5/8" (suction); however, the store tie-in may vary depending on the number of coils and the draw the case has. Depending on the case setup, the connecting point in the store may be 5/8", 7/8", or 1 1/8". Refer to the particular case you are hooking up.

Refrigerant lines should be sized as shown on the refrigeration legend furnished by the store.

Install *P-traps* (oil traps) at the base of all suction line vertical risers.

Pressure drop can rob the system of capacity. To keep the pressure drop to a minimum, keep refrigerant line run as short as possible, using the minimum number of elbows. Where elbows are required, use long radius elbows only.

For refrigerators with KOOLGAS defrost, suction, and liquid lines should not contact each other and should be insulated for a minimum of 30' from the refrigerator. Additional insulation for the balance of liquid and suction lines is recommended and required wherever condensation and dripping would be objectionable.

CONTROL SETTINGS-Remote

See the "Case Specs" section of this guidebook for the appropriate settings for your merchandiser. Maintain these parameters to achieve near constant product temperatures. Product temperature should be measured first thing in the morning, after having been refrigerated overnight. Defrost times should as directed in the Case Specifications section of this guide. The number of defrosts per day should never change. The duration of the defrost cycle may be adjusted to meet conditions present at your location.

CONTROL SETTINGS-Self Contained

On Self Contained cases all functions, defrost, fans, temperature are controlled by Pagon ERC-2 controller. See case specs for proper temperature and defrost settings.

ACCESS TO TX VALVES & DRAIN LINES

MECHANICAL - Remove product from end of case. Remove product racks. Remove refrigeration and drain access panels (labeled). TX valve (mechanical only) and drain are located under each access panel at end of the case.

ELECTRONIC - The Electronic Expansion valve master and slave cylinder(s) are located within the electrical access panel(s).

ELECTRONIC EXPANSION VALVE (OPTIONAL)

A wide variety of electronic expansion valves and case controllers can be utilized. Please refer to EEV and controller manufacturers information sheet. Sensors for electronic expansion valves will be installed on the coil inlet, coil outlet, and in the discharge air. (Some supermarkets require a 4th sensor in the return air). Case controllers will be located in the electrical raceway or under the case.

THERMOSTATIC EXPANSION VALVE LOCATION

This device is located on the same side as the refrigeration stub. A balanced port expansion valve model is furnished as standard equipment.

EXPANSION VALVE ADJUSTMENT

Expansion valves must be adjusted to fully feed the evaporator. Before attempting any adjustments, make sure the evaporator is either clear or very lightly covered with frost, and that the fixture is within 10°F of its expected operating temperature.

MEASURING THE OPERATING SUPERHEAT

1. Determine the suction pressure with an accurate pressure gauge at the evaporator outlet.
2. From a refrigerant pressure temperature chart, determine the saturation temperature at the observed suction pressure.
3. Measure the temperature of the suction gas at the thermostatic remote bulb location.
4. Subtract the saturation temperature obtained in step No.2 from the temperature measured in step No.3.
3. The difference is superheat.
5. Set the superheat for 5°F - 7°F.

T-STAT LOCATION

Thermostats are located within the electrical raceway. The raceway location is dependent on the style of the front

panel and whether the case is going to be pushed up against a wall.

back, it is the left-hand side.

Attention Installer!

It is contractor's responsibility to install case(s) according to

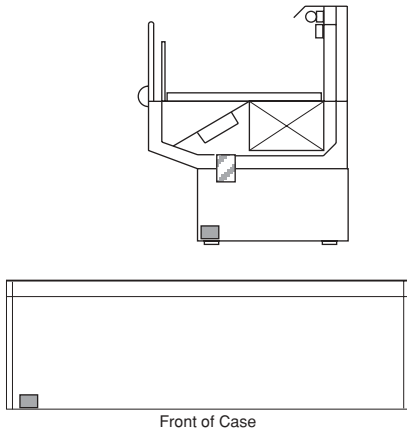

Ballast and T-stat are located in the front left hand area of the case, viewed from customer angle.

In all cases, the thermostat is located on the same side of the case. If you are looking at the case from the front, it is the right-hand side. If you are looking at the case from the

Electrical

WIRING COLOR CODE

GREEN	GROUND
PURPLE	ANTI-SWEAT
ORANGE	LIGHTS
YELLOW	RECEPTACLE
RED / BLACK	T-STAT / SOLENOID 230V
BLACK / WHITE	T-STAT / SOLENOID 115V
BROWN	FAN MOTORS

CASE MUST BE GROUNDED

NOTE: Refer to label affixed to case to determine the actual configuration as checked in the "TYPE INSTALLED" boxes.

Electrical Circuit Identification

Standard lighting for all models will be full length fluorescent lamps located on the front of the parent case. The switch controlling the lights is located on the parent case.

FIELD WIRING & SERIAL PLATE AMPERAGE

Field Wiring must be sized for component amperes printed on the serial plate. Actual ampere draw may be less than specified. Field wiring from the refrigeration control panel to the merchandisers is required for refrigeration thermostats. Most component amperes are listed in the "Case Specs" section, but always check the serial plate.

BALLAST LOCATION

Ballasts are located within the access panel that runs the length of the rear of the case. Refer to diagram on page 6.



DANGER

**BEFORE SERVICING
ALWAYS DISCONNECT ELECTRICAL
POWER AT THE MAIN DISCONNECT
WHEN SERVICING OR REPLACING ANY
ELECTRICAL COMPONENT.**

This includes (but not limited to) Fans, Heaters, Thermostats, and Lights.

Wiring Diagram

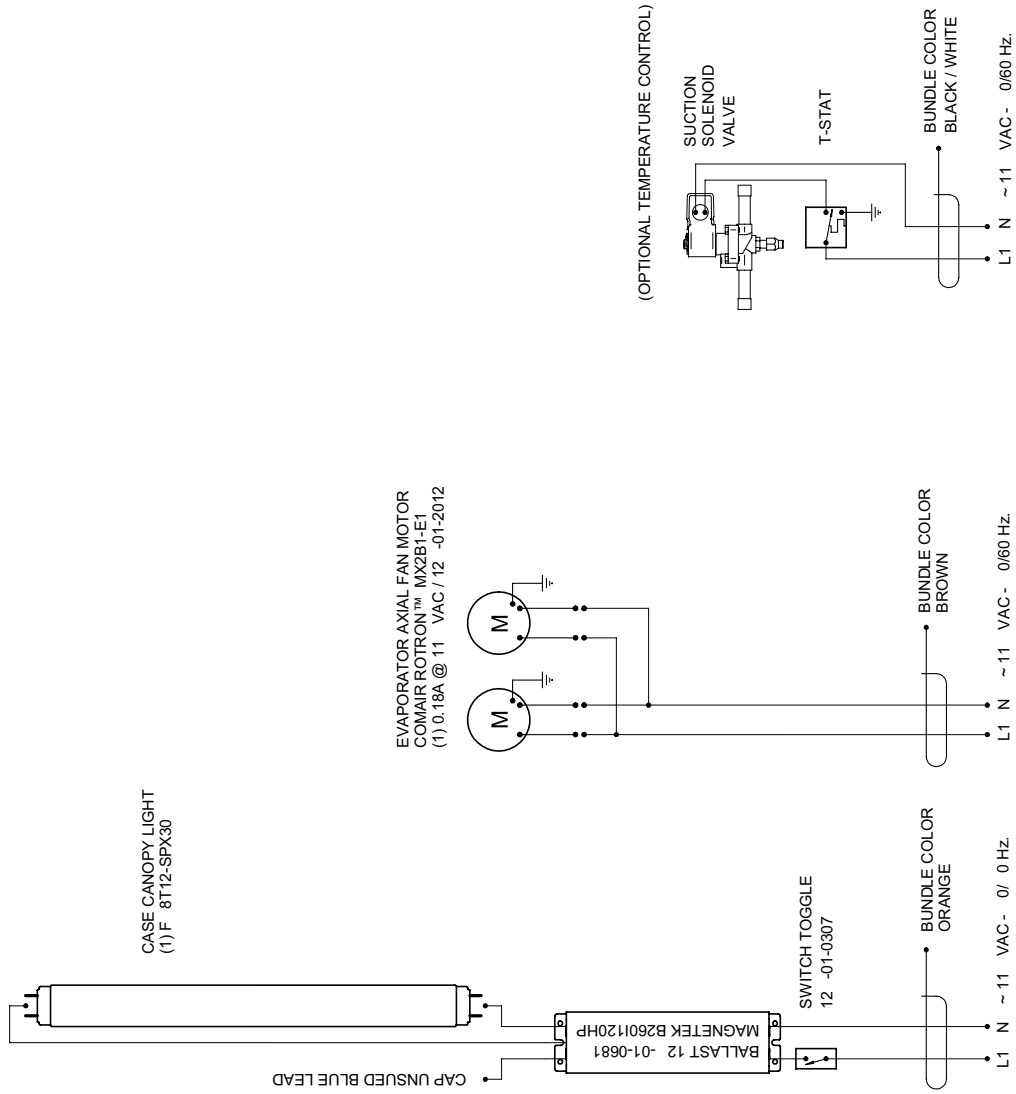

REVISIONS:		PROJECT TITLE: FMSS CASES		DWG #: W1 00000	
#	DESCRIPTION:	DATE:	BY:	CHECKED BY: AEC	DATE: 07/29/02
1					
2					
3					
			DRAWING TITLE:		
			' CASE WIRING DIAGRAM		
			FILE LOCATION:		
			H:\WIRES\HEMATICS\NEW-WIRING		
			PAGE 1 OF 1		

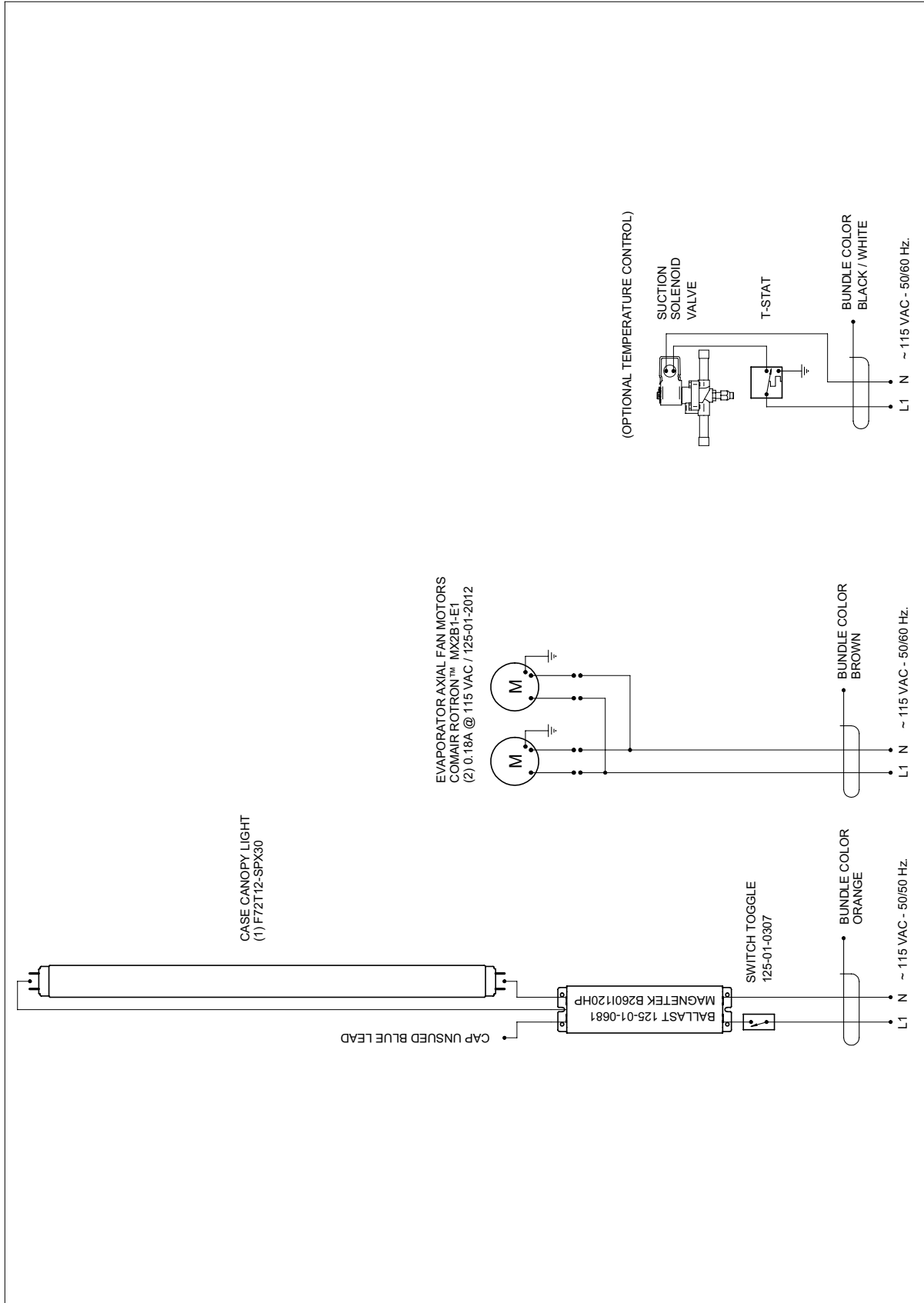

REVISIONS:		DRAWN BY: ADRIANE CRISCI	PROJECT TITLE: FMSS CASES	DWG #: W1400001
#	DESCRIPTION	DATE	BY	CHECKED BY: AEC DATE: 07/29/02
1				PRODUCTION ORDER #:
2				FILE LOCATION:
3				H:\WIRES\SCHEMATICS\NEW-WIRING
DRAWING TITLE:				PAGE 1 OF 1
6' CASE WIRING DIAGRAM				

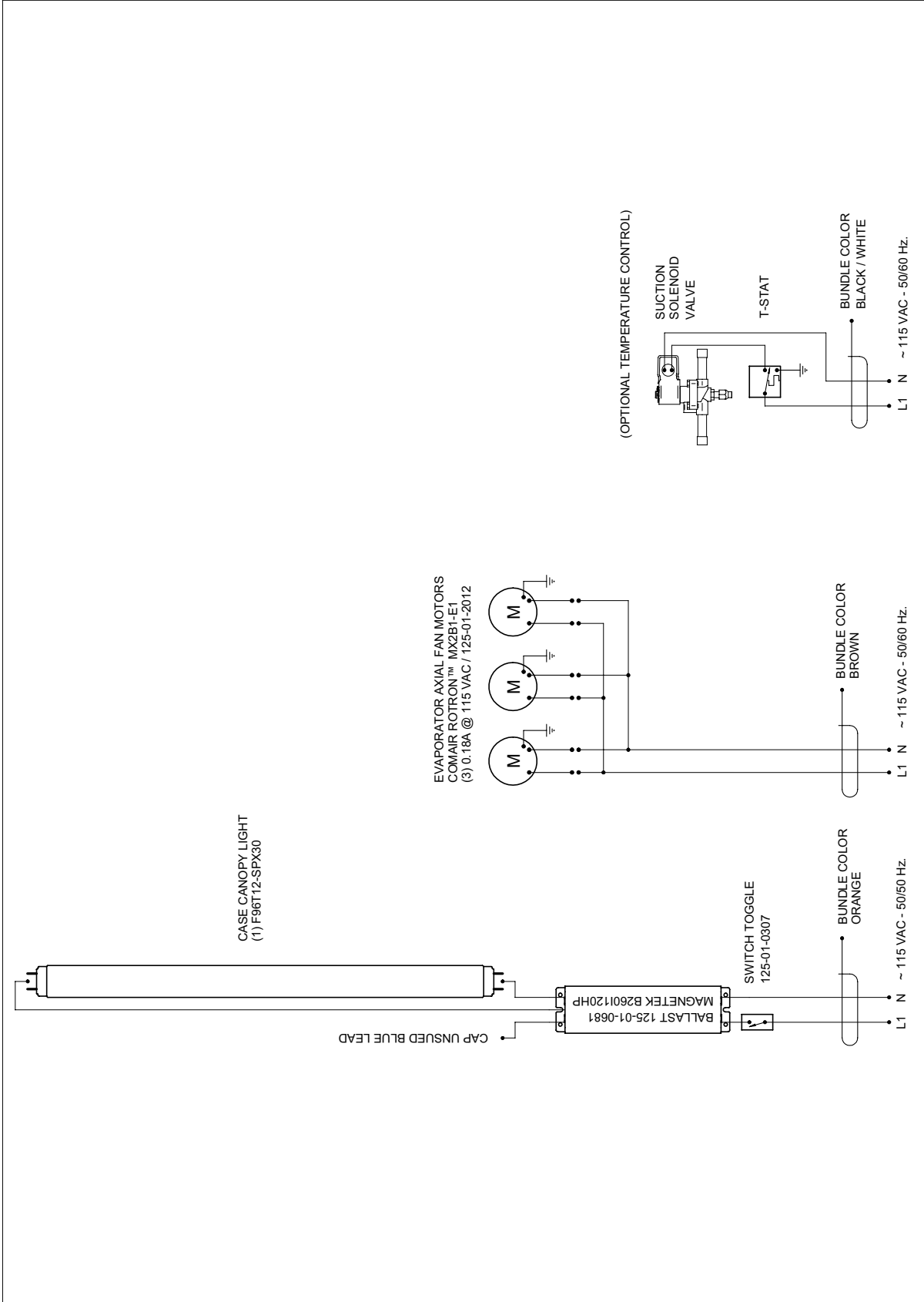

REVISIONS: #1 DESCRIPTION: #2 #3		DRAWN BY: ADRIAN E. CRISCI CHECKED BY: AEC DATE: 07/29/02 PRODUCTION ORDER #: FILE LOCATION: H:\WIRESCHEMATICS\NEW-WIRING	PROJECT TITLE: FMSS CASES DWG #: W1400002
HUSMANN CORPORATION 13770 RAMONA AVENUE CHINO, CA 91710 (909) 398-4910 Lic.# 644466		DRAWING TITLE: 8' CASE WIRING DIAGRAM	
		PAGE 1 OF 1	

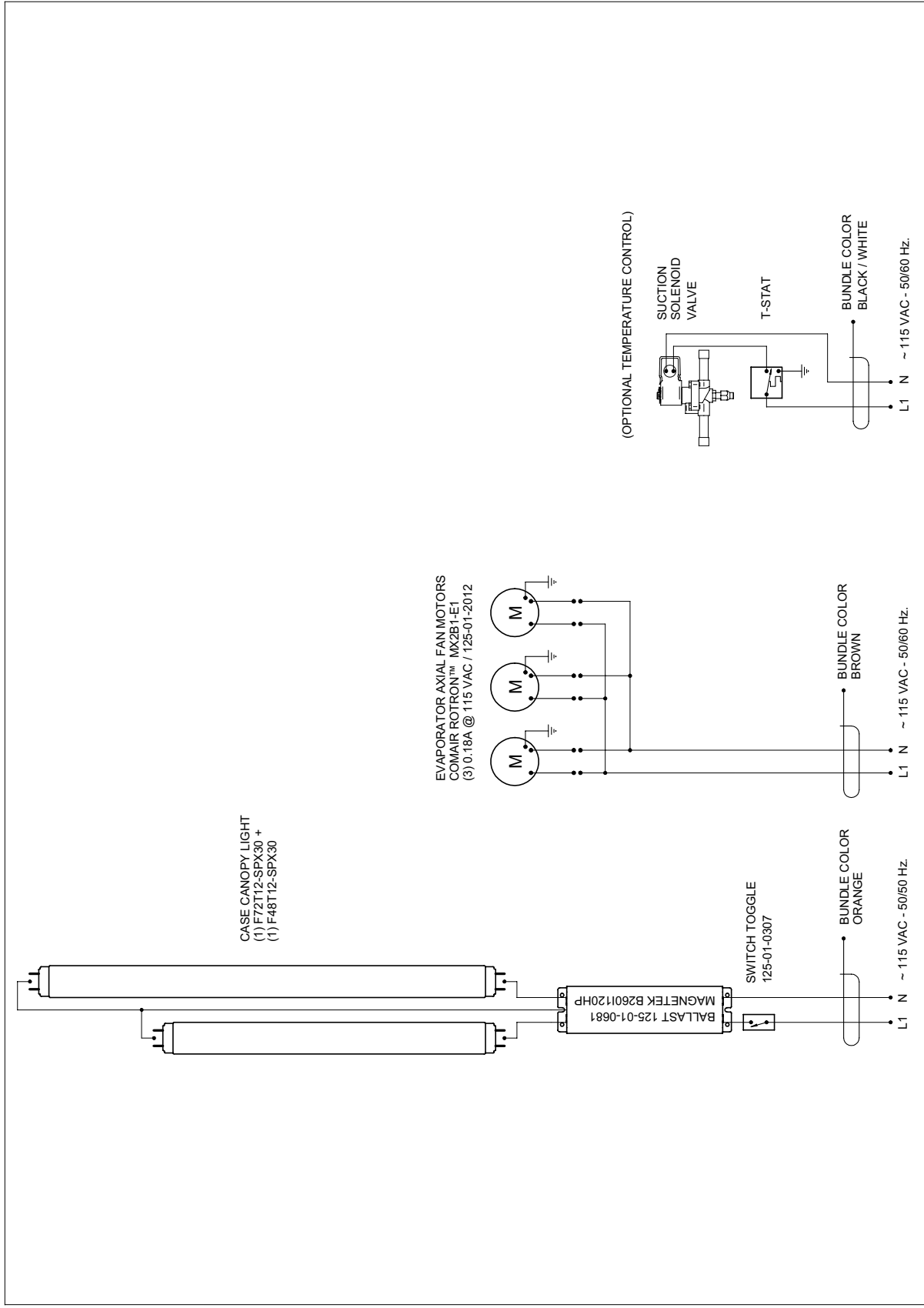

CASE CANOPY LIGHT
 (1) F7Z112-SPX30 +
 (1) F48T12-SPX30

EVAPORATOR AXIAL FAN MOTORS
 COMAIR ROTRON™ MX2B1-E1
 (3) 0.18A @ 115 VAC / 125-01-2012

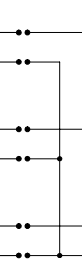
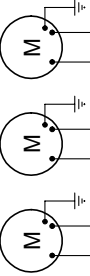

(OPTIONAL TEMPERATURE CONTROL)

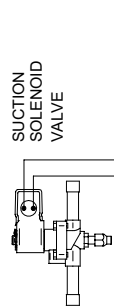

SWITCH TOGGLE
 125-01-0307

BUNDLE COLOR
 BROWN

BUNDLE COLOR
 ORANGE

BUNDLE COLOR
 BLACK / WHITE

L1 N ~ 115 VAC - 50/60 HZ.

L1 N ~ 115 VAC - 50/60 HZ.

L1 N ~ 115 VAC - 50/60 HZ.

HUSSMANN CORPORATION 13770 RAMONA AVENUE CHULA VISTA, CA 92015 (619) 590-4310 LIC.#: 644406		REVISIONS: # DESCRIPTION 1 2 3	DRAWN BY: ADRIANE CRISCI CHECKED BY: AEC DATE: 07/29/02 PRODUCTION ORDER #: FILE LOCATION: H:\WIRES\SCHEMATICS\NEW-WIRING	PROJECT TITLE: FMSS CASES DRAWING TITLE: 10' CASE WIRING DIAGRAM	DWG #: W1400003 PAGE 1 OF 1
--	--	--	--	--	--------------------------------

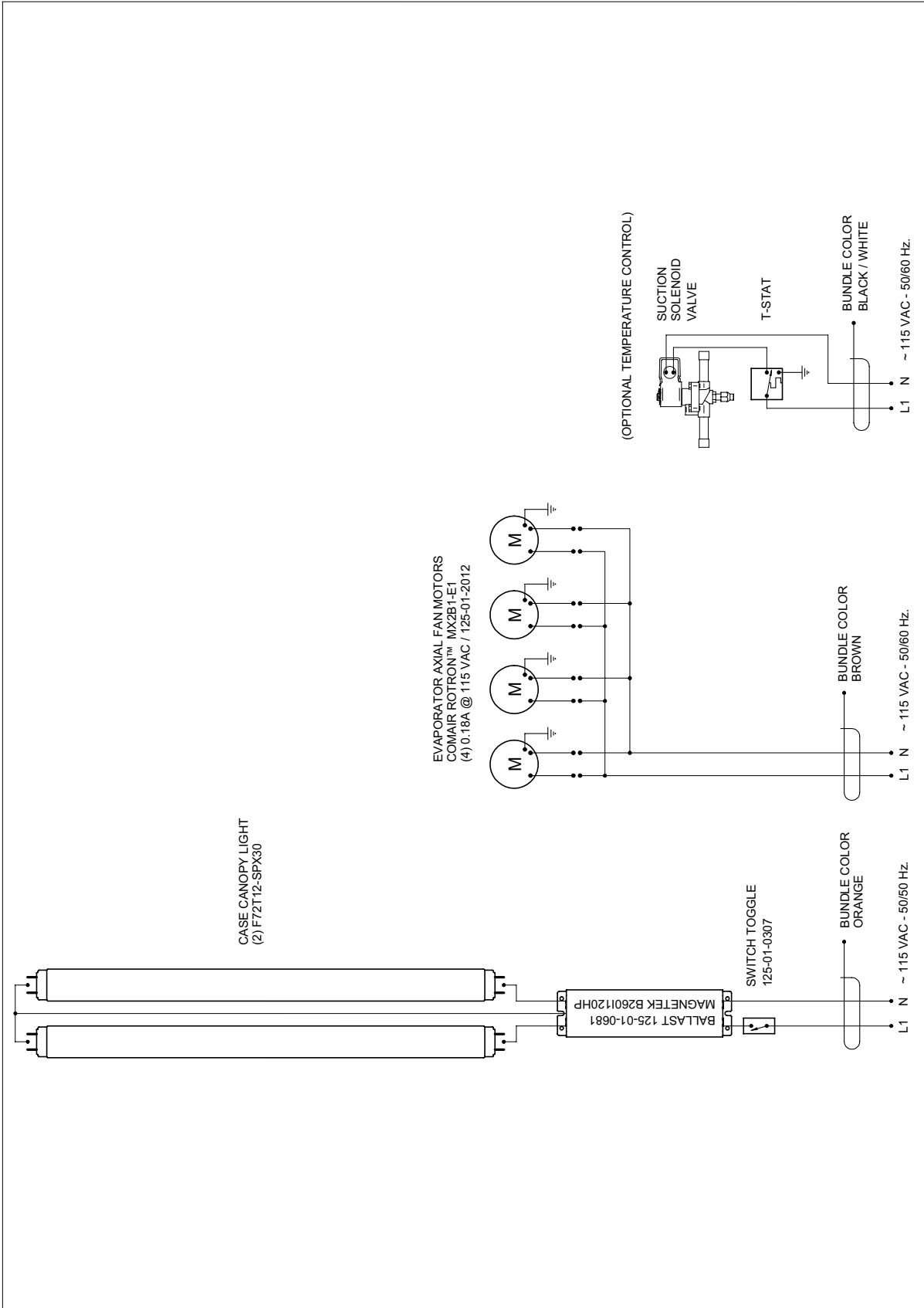

REVISIONS:		DRAWN BY: ADRIANE CRISCI		PROJECT TITLE: FMSS CASES		DWG #: W1400004	
#	DESCRIPTION:	DATE:	BY:	CHECKED BY: AEC	DATE: 07/29/02	PRODUCTION ORDER #:	
1						DRAWING TITLE:	
2						FILE LOCATION:	
3						H:\WIRES\SCHEMATICS\NEW-WIRING	
						12' CASE WIRING DIAGRAM	
						PAGE 1 OF 1	

STOCKING

Improper temperature and lighting will cause serious product loss. Discoloration, dehydration and spoilage can be controlled with proper use of the equipment and handling of product. Product temperature should always be maintained at a constant and proper temperature. This means that from the time the product is received, through storage, preparation and display, the temperature of the product must be controlled to maximize life of the product. Hussmann cases were not designed to “heat up” or “cool down” product—but rather to maintain an item’s proper temperature for maximum shelf life. To achieve the protection required always:

1. Minimize processing time to avoid damaging temperature rise to the product. Product should be at proper temperature.
2. Keep the air in and around the case area free of foreign gasses and fumes or food will rapidly deteriorate.
3. Maintain the display merchandisers temperature controls as outlined in the refrigerator section of this manual.
4. Do not place any product into these refrigerators until all controls have been adjusted and they are operating at the proper temperature. Allow merchandiser to operate a minimum of 6 hours before stocking with any product.
5. When stocking, never allow the product to extend beyond the recommended load limit. **Air discharge and return air flue must be unobstructed at all times to provide proper refrigeration.**
6. There are vents located at the base of the front of the glass, just above the front rail. These vents supply a continuous, gentle flow of air across the front glass which inhibits condensation. **Do not place any signs or other restrictive objects on the front of the refrigerator that will block these vents.**
7. Keep the service doors closed (when applicable). Refrigeration performance will be seriously affected if left open for a prolonged period of time.
8. Avoid the use of supplemental flood or spot lighting. Display light intensity has been designed for maximum visibility and product life at the factory. The use of higher output fluorescent lamps (H.O. and V.H.O.), will shorten the shelf life of the product.

IMPORTANT STEPS

1. Do not set temperature too cold, as this causes product dehydration. **Product Temperature:**

33°–35°!

Set thermostat to cut in at 28° discharge air. Meat holding box: 32°. Meat prep room: 55°. Meat bloom box: 36°.

2. Temperature control should be by means of a T-Stat and Suction Stop Solenoid at each case. Do not use EPR valves, Liquid Line Solenoids or electronic control devices of any kind, as these allow temperature swings causing dehydration and excessive energy consumption.

CASE CLEANING

Long life and satisfactory performance of any equipment are dependent upon the care given to it. To insure long life, proper sanitation and minimum maintenance costs, the refrigerator should be thoroughly cleaned frequently. **SHUT OFF FAN DURING CLEANING PROCESS.** It can be unplugged within the case, or shut off case at the source. The interior bottom may be cleaned with any domestic soap or detergent based cleaners. Sanitizing solutions will not harm the interior bottom, however, these solutions should always be used according to Hussmann’s directions. It is essential to establish and regulate cleaning procedures. This will minimize bacteria causing discoloration which leads to degraded product appearance and significantly shortening product shelf life.



PRECAUTION

CLEANING PRECAUTIONS

WHEN CLEANING:

- DO NOT USE HIGH PRESSURE WATER HOSES
- DO NOT INTRODUCE WATER FASTER THAN WASTE OUTLET CAN DRAIN
- NEVER ON A SELF CONTAINED UNIT WITH AN EVAPORATOR FAN
- NEVER USE A CLEANING OR SANITIZING SOLUTION THAT HAS AN OIL BASE (these will dissolve the butyl sealants) or an AMMONIA BASE (this will corrode the copper components of the case)

TO PRESERVE THE ATTRACTIVE FINISH:

- DO USE WATER AND A MILD DETERGENT FOR THE EXTERIOR ONLY
- DO NOT USE ABRASIVES OR STEEL WOOL SCOURING PADS (these will mar the finish)

Soap and hot water are not enough to kill this bacteria. A sanitizing solution must be included with each cleaning process to eliminate this bacteria.

1. Scrub thoroughly, cleaning all surfaces, with soap and hot water.
2. Rinse with hot water, but do not flood.
3. Apply the sanitizing solution according to Hussmann's directions.
4. Rinse thoroughly.
5. Dry completely before resuming operation.

CLEANING GLASS & MIRRORS

Only use a soft cloth and mild glass cleaner for cleaning any glass or mirrored components. Be sure to rinse and/or dry completely.

Never use hot water on cold glass surfaces! It may shatter and cause serious injury! Allow glass surfaces to warm first.

PLEXIGLASS & ACRYLIC CARE

Improper cleaning not only accelerates the cleaning cycle but also degrades the quality of this surface. Normal daily buffing motions can generate static cling attracting dust to the surface. Incorrect cleaning agents or cleaning cloths can cause micro scratching of the surface, causing the plastic to haze over time.

CLEANING

Hussmann recommends using a clean damp chamois, or a paper towel marketed as dust and abrasive free with **210® Plastic Cleaner and Polish** available by calling Sumner Labs at **1-800-542-8656**. Hard, rough cloths or paper towels will scratch the acrylic and should not be used.

ANTISTATIC COATINGS

The **210®** has proven to be very effective in not only cleaning and polishing the Plexiglass surface, but also providing anti-static and anti-fog capabilities. This product also seals pores and provides a protective coating.

Maintenance



BEFORE SERVICING – Always disconnect electrical power at the main disconnect when servicing or replacing any electrical component

This includes (but not limited to) Fans, Heaters, Thermostats, and Lights.

REPLACING FLUORESCENT LAMPS

Fluorescent lamps are furnished with moisture resistant lamp holders, shields and end caps. Whenever a fluorescent lamp is replaced, be certain to reinstall the lamp shield and end caps over the lamp. The lamps supplied are single slim-line or bi-pin type with or without starters.

HUSSMANN®

ENCAPSULITE
SHATTERPROOF COATING - SA 10645



Complies with FDA USDA
& OSHA Regulations



for replacement call:
1-800-395-9229

→ Turn switch off then on after replacing bulb ←

COPPER COILS

The copper coils used in Hussmann merchandisers may be repaired in the field. Materials are available from local refrigeration wholesalers.

Hussmann recommends using #15 Sil-Fos for repairs.

TIPS & TROUBLESHOOTING

Before calling for service, check the following:

1. Check electrical power supply to the equipment for connection.
2. Check fixture loading. Overstocking case will affect its proper operation.
3. If frost is collecting on fixture and/or product, check that Humidity Control is working properly, and that no outside doors or windows are open—allowing moisture to enter store.



**IMPORTANT
INFORMATION**

FOR PROMPT SERVICE
When contacting the factory,
be sure to have the Case Model and Serial
Number handy. This information is on a plate
located on the case itself.

EVAPORATOR FANS

The evaporator fans are located at the center front of these merchandisers directly beneath the display pans.

Specifications

FMSS Medium Temp

	BTU REQ'D PER FT.	EVAP TMP	TEMPERATURE		DISCHG. AIR VELOC @FPM	T-STAT/ CUT IN SETTINGS	TYPE & MAKE EVAP. COIL	FAN SIZE & NUMBER OF MOTORS	DEFROST FREQ. & DURATION	STD. FANS	Max 115 V. ELECTRICAL CIRCUITS			SELF CONTAINED		
			AVG PROD TMP	DISC TMP							Warmers	LIGHTS	Low Pressure Control & Settings	H.P.	VOLTS	AMPACITY
4' Remote	450	18°	35° - 37°	28°	100	Optional	Forced Air	4 1/2" Axial (1)	45 min. (3)	.18	1.16	50# In 30# Out	1/4	115	9.0	
6' Remote	450	18°	35° - 37°	28°	100	Optional	Forced Air	4 1/2" Axial (2)	45 min. (3)	.36	1.16	50# In 30# Out	1/3	115	10.9	
8' Remote	450	18°	35° - 37°	28°	100	Optional	Forced Air	4 1/2" Axial (3)	45 min. (3)	.54	1.16	50# In 30# Out	1/2	115	19.9	
10' Remote	450	18°	35° - 37°	28°	100	Optional	Forced Air	4 1/2" Axial (3)	45 min. (3)	.54	1.16	50# In 30# Out	3/4	208/ 240	8.7	
12' Remote	450	18°	35° - 37°	28°	100	Optional	Forced Air	4 1/2" Axial (4)	45 min. (3)	.72	1.16	50# In 30# Out	3/4	208/ 240	8.7	

NOTES: These refrigerated merchandisers have been designed for use in stores where temperatures and humidity are maintained at or below 75°F and 55%RH. Stores are responsible for setting their cases appropriately in conditions which vary from the above. The number of defrosts and/or the duration may vary for cases displaying products for which they were not designed. Italicized data indicates optional equipment.

These case specs serve as a guideline for planning purposes and installation. Please consult the label on the back of the case to verify actual case loads.

Appendices

APPENDIX A. – Temperature Guidelines

The refrigerators should be operated according to Hussmann's published engineering specifications for entering air temperatures for specific equipment applications. Table I shows the typical temperature of the air entering the food zone one hour before the start of defrost and one hour after defrost for various categories of refrigerators. Refer to Appendix C for Field Evaluation Guidelines.

TABLE I

Type of Refrigerator	Typical Entering Air Temperature
I. OPEN DISPLAY	
A. Non frozen:	
1) Meat	28°F
2) Dairy/Deli	32°F
3) Produce	
a. Processed	36°F
b. Unprocessed	45°F
B. Frozen	0°F
C. Ice Cream	-5°F
II. CLOSED DISPLAY	
A. Non frozen:	
1) Meat	34°F
2) Dairy/Deli	34°F
3) Produce	
a. Processed	36°F
b. Unprocessed	45°F
B. Frozen	0°F
C. Ice Cream	-5°F

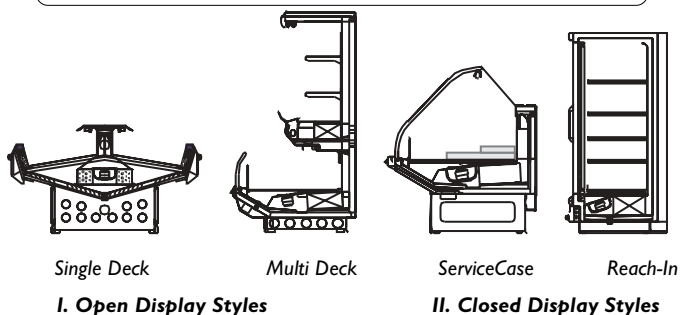

APPENDIX B. – Application Recommendations

1.0 Temperature performance is critical for controlling bacteria growth. Therefore, the following recommendations are included in the standard. They are based on confirmed field experience over many years.

- 1.1 The installer is responsible for following the installation instructions and recommendations provided by Hussmann for the installation of each individual type refrigerator.
- 1.2 Refrigeration piping should be sized according to the equipment manufacturer's recommendations and installed in accordance with normal refrigeration practices. Refrigeration piping should be

insulated according to Hussmann's recommendations.

- 1.3 A clogged waste outlet blocks refrigeration. The installer is responsible for the proper installation of the system which dispenses condensate waste through an air gap into the building indirect waste system.
- 1.4 The installer should perform a complete start-up evaluation prior to the loading of food into the refrigerator, which includes such items as:
 - a) Initial temperature performance, Coils should be properly fed with a refrigerant according to manufacturer's recommendations.
 - b) Observation of outside influences such as drafts, radiant heating from the ceiling and from lamps. Such influence should be properly corrected or compensated for.
 - c) At the same time, checks should be made of the store dry-bulb and wet-bulb temperatures to ascertain that they are within the limits prescribed by Hussmann.
 - d) Complete start-up procedures should include checking through a defrost to make certain of its adequate frequency and length without substantially exceeding the actual needs. This should include checking the electrical or refrigerant circuits to make sure that defrosts are correctly programmed for all the refrigerators connected to each refrigeration system.
 - e) Recording instruments should be used to check performance.

APPENDIX C. – Field Recommendations

Recommendations for field evaluating the performance of retail food refrigerators

1.0 The most consistent indicator of display refrigerator performance is temperature of the air entering the product zone (see Appendix A). In practical use, the precise determination of return air temperature is extremely difficult. Readings of return air temperatures will be variable and results will be inconsistent. The product temperature alone is not an indicator of refrigerator performance.

NOTE: Public Health will use the temperature of the product in determining if the refrigerator will be allowed to display potentially hazardous food. For the purpose of this evaluation, product temperature above the FDA Food Code 1993 temperature for potentially hazardous food will be the first indication that an evaluation should be performed. It is expected that all refrigerators will keep food at the FDA Food Code 1993 temperature for potentially hazardous food.

- 1.1 The following recommendations are made for the purpose of arriving at easily taken and understood data which, coupled with other observations, may be used to determine whether a display refrigerator is working as intended:
 - a) **INSTRUMENT** – A stainless steel stem-type thermometer is recommended and it should have a dial a minimum of 1 inch internal diameter. A test thermometer scaled only in Celsius or dually scaled in Celsius and Fahrenheit shall be accurate to 1°C (1.8°F). Temperature measuring devices that are scaled

only in Fahrenheit shall be accurate to 2°F. The thermometer should be checked for proper calibration. (It should read 32°F when the stem is immersed in an ice water bath).

- b) LOCATION — The probe or sensing element of the thermometer should be located in the airstream where the air first enters the display or storage area, and not more than 1 inch away from the surface and in the center of the discharge opening.
- c) READING — It should first be determined that the refrigerator is refrigerating and has operated at least one hour since the end of the last defrost period. The thermometer reading should be made only after it has been allowed to stabilize, i.e., maintain a constant reading.
- d) OTHER OBSERVATIONS — Other observations should be made which may indicate operating problems, such as unsatisfactory product, feel/appearance.
- e) CONCLUSIONS — In the absence of any apparent undesirable conditions, the refrigerator should be judged to be operating properly. If it is determined that such condition is undesirable, i.e., the product is above proper temperature, checks should be made for the following:
 - 1. Has the refrigerator been loaded with warm product?
 - 2. Is the product loaded beyond the “Safe Load Line” markers?
 - 3. Are the return air ducts blocked?
 - 4. Are the entering air ducts blocked?
 - 5. Is a dumped display causing turbulent air flow and mixing with room air?
 - 6. Are spotlights or other high intensity lighting directed onto the product?
 - 7. Are there unusual draft conditions (from heating /air-conditioning ducts, open doors, etc.)?
 - 8. Is there exposure to direct sunlight?
 - 8. Are display signs blocking or diverting airflow?
 - 9. Are the coils of the refrigerator iced up?
 - 11. Is the store ambient over 75°F, 55% RH as set forth in ASHRAE Standard 72 and ASHRAE Standard 117?
 - 12. Are the shelf positions, number, and size other than recommended by Hussmann?
 - 13. Is there an improper application or control system?
 - 14. Is the evaporator fan motor/blade inoperative?
 - 15. Is the defrost time excessive?
 - 16. Is the defrost termination, thermostat (if used) set too high?
 - 17. Are the refrigerant controls incorrectly adjusted?
 - 18. Is the air entering the condenser above design conditions? Are the condenser fins clear of dirt, dust, etc.?
 - 19. Is there a shortage of refrigerant?
 - 20. Has the equipment been modified to use replacements for CFC-12, CFC-502 or other refrigerant? If so, have the modifications been made in accordance with the recommendations of the equipment

manufacturer? Is the refrigerator charged with the proper refrigerant and lubricant? Does the system use the recommended compressor?

APPENDIX D. – Recommendations to user

- 1.0 Hussmann should provide instructions and recommendations for proper periodic cleaning. The user will be responsible for such cleaning, including the cleaning of low temperature equipment within the compartment and the cooling coil area(s). Cleaning practices, particularly with respect to proper refrigerator unloading and warm-up, must be in accordance with applicable recommendations.
- 1.1 Cleaning of non frozen food equipment should include a weekly cleaning of the food compartment as a minimum to prevent bacteria growth from accumulating. Actual use and products may dictate more frequent cleaning. Circumstances of use and equipment design must also dictate the frequency of cleaning the display areas. Weekly washing down of the storage compartment is also recommended, especially for equipment subject to drippage of milk or other liquids, or the collection of vegetable, meat, crumbs, etc. or other debris or litter. Daily cleaning of the external areas surrounding the storage or display compartments with detergent and water will keep the equipment presentable and prevent grime buildup.
- 1.2 Load levels as defined by Hussmann must be observed.
- 1.3 The best preservation is achieved by following these rules:
 - a) Buy quality products.
 - b) Receive perishables from transit equipment at the ideal temperature for the particular product.
 - c) Expedite perishables to the store’s storage equipment to avoid unnecessary warm-up and prolonged temperature recovery. Food store refrigerators are not food chillers nor can they reclaim quality lost through previous mishandling.
 - d) Care must be taken when cross merchandising products to ensure that potentially hazardous vegetable products are not placed in non refrigerated areas.
 - e) Display and storage equipment doors should be kept closed during periods of inactivity.
 - f) Minimize the transfer time of perishables from storage to display.
 - g) Keep meat under refrigeration in meat cutting and processing area except for the few moments it is being handled in processing. When a cut or tray of meat is not to be worked on immediately, the procedure should call for returning it to refrigeration.
 - h) Keep tools clean and sanitized. Since mechanical equipment is used for fresh meat processing, all such equipment should be cleaned at least daily and each time a different kind of meat product comes in contact with the tool or equipment.
 - i) Make sure that all refrigeration equipment is installed and adjusted in strict accordance with Hussmann’s recommendations.
 - j) See that all storage and refrigeration equipment is kept in proper working order by routine maintenance.

HUSSMANN® Limited Warranty

This warranty is made to the original user at the original installation site and is not transferable.

Hussmann merchandisers are warranted to be free from defect in material and workmanship under normal use and service for a period of one (1) year from the date of original installation (not to exceed fifteen (15) months from the date of shipment for the factory). **Hussmann Impact Modular Coils are warranted for a total of five (5) years based upon the above criteria.** Hussmann's obligation under this warranty shall be limited to repairing or exchanging any part or parts, without charge F.O.B. factory or nearest authorized parts depot within said period and which is proven to the satisfaction of the original manufacturing plant warranty group to be thus defective.

Hussmann covers the entire case or refrigeration product and all its components (except for lamps, driers, fuses, and other maintenance type replacement parts) for the one (1) year warranty period.

Additionally, Hussmann warrants for a total period of three (3) years all sealed, multi-glass assemblies except those used in sliding doors on closed meat display cases. If within three (3) years from the date of installation (not to exceed thirty-nine (39) months from the date of shipment from factory), it shall be proven to the satisfaction of the originating factory warranty group that there is impaired visibility through the multi-glass assemblies thereof caused by moisture between the glasses, the multi-glass assembly will be replaced free of charge, F.O.B. factory. This additional warranty excludes accident, misuse, or glass breakage.

On Hussmann manufactured self-contained display cases, Hussmann agrees to repair or exchange, at its option, the original motor/compressor unit only with a motor/compressor of like or of similar design and capacity if it is shown to the satisfaction of Hussmann that the motor/compressor is inoperative due to defects in factory workmanship or material under normal use and service as outlined in Hussmann's "Installation Instructions" which are shipped inside new Hussmann equipment. Hussmann's sole obligation under this warranty shall be limited to a period not to exceed five years from date of factory shipment.

On Hussmann refrigeration systems, an additional (4) year extended warranty for the motor/compressor assembly is available, but must be purchased prior to shipment to be in effect. Hussmann reserves the right to inspect the job site, installation and reason for failure.

The motor/compressor warranties listed above do not include replacement or repair of controls, relays, capacitors, overload protectors, valve plates, oil pumps, gaskets or any external part on the motor/compressor replaceable in the field, or any other part of the refrigeration system or self-contained display case.

THE WARRANTIES TO REPAIR OR REPLACE ABOVE RECITED ARE THE ONLY WARRANTIES, EXPRESS, IMPLIED OR STATUTORY, MADE BY HUSSMANN WITH RESPECT TO THE ABOVE MENTIONED EQUIPMENT, INCLUDING ANY IMPLIED WARRANTY OF MERCHANTABILITY OR FITNESS, AND HUSSMANN NEITHER ASSUMES NOR AUTHORIZES ANY PERSON TO ASSUME FOR IT, ANY OTHER OBLIGATION OR LIABILITY IN CONNECTION WITH THE SALE OF SAID EQUIPMENT OR ANY PART THEREOF.

THIS WARRANTY SHALL NOT APPLY TO LOSS OF FOOD OR CONTENTS OF THE EQUIPMENT DUE TO FAILURE FOR ANY REASON. HUSSMANN SHALL NOT BE LIABLE:

- For payment of labor for any removal or installation of warranted parts;
- For any repair or replacements made without the written consent of Hussmann, or when the equipment is installed or operated in a manner contrary to the printed instructions covering installation and service which accompanied such equipment;
- For any damages, delays, or losses, direct or consequential which may arise in connection with such equipment or part thereof;
- For damages caused by fire, flood, strikes, acts of God or circumstances beyond its control;
- When the equipment is subject to negligence, abuse, misuse or when the serial number of the equipment has been removed, defaced, or altered;
- When the equipment is operated on low or improper voltages
- When the equipment is put to a use other than normally recommended by Hussmann (i.e. deli case used for fresh meat);
- When operation of this equipment is impaired due to improper drain installation;
- For payment of refrigerant loss for any reason;
- For costs related to shipping or handling of replacement parts.

Hussmann Corporation, Corporate Headquarters: Bridgeton, Missouri, U.S.A. 63044 August 1, 1998

Service Record

Last service date: By:

_____	_____
_____	_____
_____	_____
_____	_____
_____	_____
_____	_____
_____	_____
_____	_____

HUSSMANN®/Chino

Additional copies of this publication may be obtained by contacting:
Hussmann® Chino
13770 Ramona Avenue • Chino, California 91710
(909) 628-8942 FAX
(909) 590-4910
(800) 395-9229

The <i>MODEL NAME</i> and <i>SERIAL NUMBER</i> is required in order to provide you with the correct parts and information for your particular unit. They can be found on a small metal plate on the unit. Please note them below for future reference. MODEL: _____ SERIAL NUMBER: _____
--