

# Combat®

## UHD-Series Tubular Duct Furnace (Low Profile Range) Installation, Operation & Service Manual

Models UHD[X][S][R]  
75, 100, 125



### FOR YOUR SAFETY

*If you smell gas:*

1. Open windows.
2. **DO NOT** try to light any appliance.
3. **DO NOT** use electrical switches.
4. **DO NOT** use any telephone in your building.
5. Leave the building.
6. Immediately call your local gas supplier after leaving the building. Follow the gas supplier's instructions.
7. If you cannot reach your gas supplier, call the Fire Department.

### ⚠ WARNING



#### Fire Hazard

Do not store or use gasoline or other flammable vapors and liquids in the vicinity of this or any other appliance.

Some objects can catch fire or explode when placed close to heater.

Failure to follow these instructions can result in death, injury or property damage.

### ⚠ WARNING

Improper installation, adjustment, alteration, service or maintenance can result in death, injury or property damage. Read the Installation, Operation and Service Manual thoroughly before installing or servicing this equipment.

Installation must be done by a contractor qualified in the installation and service of gas-fired heating equipment or your gas supplier.

#### Installer

Please take the time to read and understand these instructions prior to any installation. Installer must give a copy of this manual to the owner.

#### Owner

Keep this manual in a safe place in order to provide your serviceman with necessary information.



#### Roberts-Gordon LLC

1250 William Street  
P.O. Box 44  
Buffalo, New York 14240-0044  
Telephone: 716.852.4400  
Fax: 716.852.0854  
Toll Free: 800.828.7450

[www.rg-inc.com](http://www.rg-inc.com)

Quality in Any Language™



## TABLE OF CONTENTS

<b>SECTION 1: Heater Safety</b> .....	<b>1</b>	<b>SECTION 10: Operation and Maintenance</b> .....	<b>23</b>
1.1 Manpower Requirements .....	1	10.1 Pre-Start-Up Checks .....	23
<b>SECTION 2: Installer Responsibility</b> .....	<b>2</b>	10.2 Begin Start-Up .....	23
2.1 Wall Tag .....	2	10.3 Complete Start-Up .....	25
2.2 Corrosive Chemicals.....	2	<b>SECTION 11: User Instructions</b> .....	<b>26</b>
2.3 National Standards and Applicable Codes .....	2	11.1 User Instructions .....	26
<b>SECTION 3: Critical Considerations</b> .....	<b>3</b>	11.2 Heater Operation .....	26
3.1 Basic Information .....	3	11.3 Common User Controls.....	26
3.2 Manufactured Units.....	3	11.4 Lighting Instructions .....	26
3.3 Location and Suspension .....	3	11.5 Simple Troubleshooting.....	27
3.4 Minimum Required Installation Clearances .....	3	<b>SECTION 12: Servicing</b> .....	<b>28</b>
3.5 Clearances to Combustibles .....	3	12.1 Servicing Instructions.....	28
3.6 Ventilation .....	4	12.2 Burner Maintenance.....	28
3.7 Gas Supply .....	4	12.3 Heat Exchanger Maintenance.....	28
3.8 Electrical Supply .....	4	12.4 Gas Valve Maintenance .....	28
3.9 Vent.....	4	12.5 Flue Blower .....	28
<b>SECTION 4: National Standards and Applicable Codes</b> .....	<b>5</b>	12.6 Venting and Air Intake Pipe.....	28
4.1 Gas Codes.....	5	12.7 Maintenance Checklist.....	29
4.2 Aircraft Hangars .....	5	<b>SECTION 13: Troubleshooting</b> .....	<b>31</b>
4.3 Parking Structures and Repair Garages.....	5	13.1 General .....	31
4.4 Electrical .....	5	13.2 Troubleshooting For Automatic Ignition Burner Systems .....	32
4.5 Venting.....	5	13.3 Troubleshooting for Flame Supervision System .....	33
4.6 High Altitude .....	6	13.4 Troubleshooting for Gas Valves.....	34
<b>SECTION 5: Duct Heater Installation</b> .....	<b>7</b>	13.5 Troubleshooting for Flue Blower .....	34
5.1 General .....	7	<b>SECTION 14: Replacement Parts</b> .....	<b>35</b>
5.2 Shelf Mounting and Suspension.....	8	14.1 Gas Valve .....	35
5.3 Wall Mounting .....	8	14.2 Burner Compartment .....	36
<b>SECTION 6: Venting</b> .....	<b>10</b>	14.3 Ignition Electrode and Flame Probe .....	37
6.1 Changing Vent and Air Intake Orientation.....	10	14.4 Heat Exchanger .....	37
6.2 Venting.....	10	14.5 Flue Blower Vertical Installation .....	38
6.3 Vent Installation .....	10	14.6 Pressure Switch.....	39
6.4 Unvented Operation.....	11	14.7 Ignition Control .....	39
6.5 Horizontal Venting.....	11	14.8 Limit Switches .....	39
6.6 Vertical Venting.....	11	<b>SECTION 15: Specifications</b> .....	<b>40</b>
6.7 Length Requirements .....	11	15.1 Dimension Data.....	40
6.8 Vent Material.....	12	15.2 General Technical Data Table .....	41
6.9 Replacing an Existing Heater in a Venting System .....	12	15.3 Technical Data Table .....	41
<b>SECTION 7: Air Supply</b> .....	<b>17</b>	<b>SECTION 16: ROBERTS GORDON® COMBAT® UHD-Series Warranty</b> .....	<b>43</b>
7.1 Separated Combustion Installation.....	17		
7.2 Unvented Installation .....	17		
7.3 Building Ventilation .....	17		
7.4 Outside Combustion Air Supply.....	17		
<b>SECTION 8: Gas Piping</b> .....	<b>18</b>		
8.1 Connections.....	18		
<b>SECTION 9: Wiring</b> .....	<b>19</b>		
9.1 Positioning Thermostats .....	19		
9.2 Low Voltage Thermostat with One Heater .....	19		
9.3 Internal Wiring Diagram .....	20		
9.4 Ladder Wiring Diagram.....	21		
9.5 Electrical Connection to the Heater .....	22		

© 2008 Roberts-Gordon LLC

All rights reserved. No part of this work covered by the copyrights herein may be reproduced or copied in any form or by any means - graphic, electronic, or mechanical, including photocopying, recording, taping or information storage and retrieval systems - without the written permission of Roberts-Gordon LLC.

Printed in U.S.A.

---

---

## TABLE OF FIGURES

Figure 1: Clearances to Combustibles .....	3
Figure 2: Air Flow Direction.....	7
Figure 3: Suspension Methods .....	8
Figure 4: Shelf-Mounting Methods.....	9
Figure 5: Wall Shelf Mounting and Suspension .....	9
Figure 6: Vent and Roof Detail.....	13
Figure 7: Standard Vented Heater - Vertical and Horizontal Vent Termination.....	13
Figure 8: Standard Vented Heater - Common Vertical Vent Termination .....	14
Figure 9: Separated Combustion Heater - Vertical and Horizontal Vent Termination.....	15
Figure 10: Concentric Vent Box.....	15
Figure 11: Concentric Vertical and Horizontal Vent Termination - Separated Combustion Heater.....	16
Figure 12: Gas Connection .....	18
Figure 13: Automatic Burner Control Sequence.....	24
Figure 14: Gas Valve .....	24
Figure 15: Manual Reset Limit Switch.....	26
Figure 16: LED Diagnostic Codes.....	27

---

**SECTION 1: HEATER SAFETY**

Your Safety is Important to Us!  
This symbol is used throughout the manual to notify you of possible fire, electrical or burn hazards. Please pay special attention when reading and following the warnings in these sections.

Installation, service and quarterly inspection of heater must be done by a contractor qualified in the installation and service of gas-fired heating equipment.

Read this manual carefully before installation, operation or service of this equipment.

Heaters are not approved for residential installations. These instructions, the layout drawing, local codes and ordinances and applicable standards that apply to gas piping, electrical wiring, venting, etc. must be thoroughly understood before proceeding with the installation.

Protective gear is to be worn during installation, operation and service. Thin sheet metal parts, including the various venting components, have sharp edges. To prevent injury, the use of work gloves is recommended.

Before installation, check that the local distribution conditions, nature of gas and pressure and adjustment of the appliance are compatible.

**1.1 Manpower Requirements**

To prevent personal injury and damage to the heater, two persons will be required for installation.

## SECTION 2: INSTALLER RESPONSIBILITY

The installer is responsible for the following:

- To install the heater, as well as the gas and electrical supplies, in accordance with applicable specifications and codes. Roberts-Gordon recommends the installer contact a Local Building Inspector or Fire Marshal for guidance.
- To use the information given in a layout drawing and in the manual together with the cited codes and regulations to perform the installation.
- To install the heater in accordance with the clearances to combustibles.
- To furnish all needed materials not furnished as standard equipment.
- To plan location of supports, vents and air intakes.
- To provide access for servicing.
- To provide the owner with a copy of this Installation, Operation and Service Manual.
- To never use heater as support for a ladder or other access equipment and never hang or suspend anything from heater.
- To ensure there is adequate air circulation around the heater and to supply air for combustion, ventilation and distribution in accordance with local codes.
- To provide a method that ensures that the air flow through the heat exchanger is within the acceptable range indicated on the rating plate prior to energizing the heater, and that such air flow continues at least 90 seconds after the heater is de-energized.

### 2.1 Wall Tag

A laminated wall tag is included with the heater as a permanent reminder of the safety instructions and the importance of the required clearances to combustibles. Affix the tag by peeling off the backing of the adhesive strips on the rear surface and position the tag on a wall near the heater.

A copy of the wall tag (P/N 91039831) is illustrated on the back cover.

Know your model number. Model number is found on the heater and throughout the Installation, Operation and Service Manual.

### 2.2 Corrosive Chemicals

**Caution:** Do not use heater in an area containing corrosive chemicals. Avoid the use of corrosive chemicals to ensure a longer life of the burner, heat exchanger and other parts.

Roberts-Gordon cannot be responsible for ensuring that all appropriate safety measures are undertaken prior to installation; this is entirely the responsibility of the installer. It is essential that the contractor, the sub-contractor, or the owner identifies the presence of combustible materials, corrosive chemicals or halogenated hydrocarbons\* anywhere in the premises.

*\* **Halogenated Hydrocarbons** are a family of chemical compounds characterized by the presence of halogen elements (fluorine, chlorine, bromine, etc.). These compounds are frequently used in refrigerants, cleaning agents, solvents, etc. If these compounds enter the air supply of the burner, the life span of the heater components will be greatly reduced. An outside air supply must be provided to the burners whenever the presence of these compounds is suspected. Warranty will be invalid if the heater is exposed to halogenated hydrocarbons.*

### 2.3 National Standards and Applicable Codes

All appliances must be installed in accordance with the latest revision of the applicable standards and national codes. This refers also to the electric, gas and venting installation. Note: Additional standards for installations in public garages, aircraft hangars, etc. may be applicable.



## SECTION 3: CRITICAL CONSIDERATIONS

### 3.1 Basic Information

UHD[X][S][R] heaters have automatic ignition burners for ON/OFF operation only.

### 3.2 Manufactured Units

Gas-fired, power-vented duct furnace with tubular heat exchanger. Units shall have a minimum of 82% thermal efficiency. The standard unit shall consist of a non-separated combustion design with an aluminized heat exchanger. Design and heat exchanger alternatives shall be offered as follows:

- **Separated Combustion:** A separated combustion unit shall feature an enclosed, sealed burner box. A piece of flexible air duct connects this burner box to a flange on the cabinet. Combustion air should be ducted from outside the heated space, with the ductwork connecting to the unit with the use of the flange.
- **Stainless Steel Heat Exchanger:** A stainless steel heat exchanger unit shall consist of heat exchanger tubes, heat exchanger tube supports, heat exchanger tube plates and vent box produced of 409 stainless steel.

### 3.3 Location and Suspension

All models:

- Must be installed indoors.
- Must be installed on the positive pressure side of the air circulation blower.
- Must be installed in a level position with horizontal discharge.
- May be mounted on a shelf of non-combustible material using shelf mounting brackets. (See *Page 9, Figure 4* and *Page 9, Figure 5* for details.)
- May be suspended from above (See *Page 8, Figure 3*) or from wall brackets of sufficient strength to support the heater as listed in the Dimension Data Table on *Page 40, Section 15.1*.
- Must be installed in a manner which allows access to all serviceable components. See *Page 3, Figure 1* for details.

### 3.4 Minimum Required Installation Clearances

Clearances around the heater and vent must be as indicated on *Page 3, Figure 1* and *Page 13, Figure 6* through *Page 16, Figure 11* to ensure access for servicing, and correct operation.

### 3.5 Clearances to Combustibles

⚠ **WARNING**



**Fire Hazard**

**Some objects can catch fire or explode when placed close to heater.**

**Keep all flammable objects, liquids and vapors the required clearances to combustibles away from heater.**



**Failure to follow these instructions can result in death, injury or property damage.**

Clearances must be as indicated on *Page 3, Figure 1*. If clearances to combustibles are not indicated, then installation clearances apply.

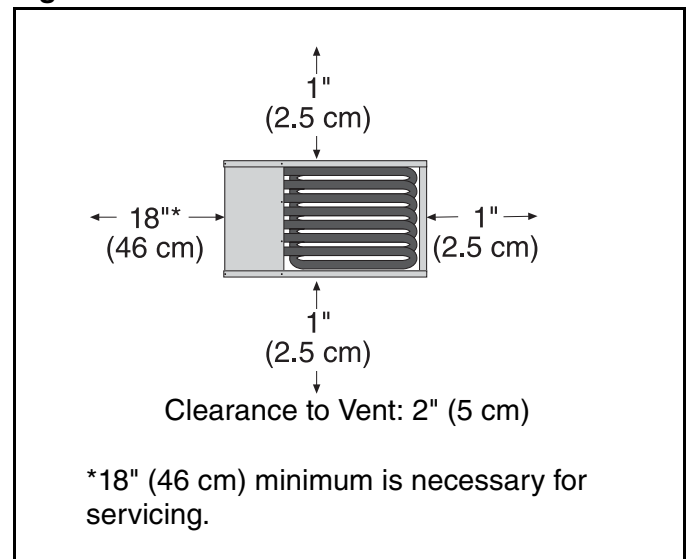
**Figure 1: Clearances to Combustibles**





### 3.6 Ventilation

 <b>WARNING</b>	
	<b>Carbon Monoxide Hazard</b>
	Heaters may be installed vented or unvented.
	Vented heaters must be vented outdoors.
	Unvented heaters must be installed in buildings with ventilation rates as per section 6.4.
	Failure to follow these instructions can result in death or injury.



It is important to ensure that there is adequate air space around the heater to supply air for combustion, ventilation and distribution in accordance with local and national codes. See Page 10, Section 6.

### 3.7 Gas Supply

 <b>WARNING</b>	
	
<b>Fire Hazard</b>	
Connect gas supply according to Figure 12.	
Do not use gas supply pipe and electrical connections to support heater's weight.	
Gas can leak if not installed properly.	
Failure to follow these instructions can result in death, injury or property damage.	

It is important that the gas supply pipe is sized correctly to provide the inlet pressure as stated on the heater data plate. The gas supply pipe and electrical connections must not support any of the heater's weight. See Page 18, Section 8.

### 3.8 Electrical Supply

 <b>WARNING</b>	
	
<b>Electrical Shock Hazard</b>	
Disconnect electrical and gas supply before servicing.	
This appliance must be connected to a properly grounded electrical source.	
Failure to follow these instructions can result in death or electrical shock.	

A permanent 120 V / 1 Ø/60 Hz electrical supply is required for the main electrical power. The heater also requires suitable controls in accordance with Page 19, Section 9.

### 3.9 Vent

Choose heater orientation to allow for proper location of the vent. Each heater must be fitted with a correctly sized sealed vent system. If vented horizontally, no other appliance may be connected to the vent. See Page 10, Section 6.

**SECTION 4: NATIONAL STANDARDS AND APPLICABLE CODES****4.1 Gas Codes**

The type of gas appearing on the name plate must be the type of gas used. Installation must comply with national and local codes and requirements of the local gas company.

United States: Refer to NFPA 54/ ANSI Z223.1 - latest revision, National Fuel Gas Code.

Canada: Refer to CSA B149.1 Natural Gas and Propane Installation Code.

**4.2 Aircraft Hangars**

Installation in aircraft hangars must be in accordance with the following codes:

United States: Refer to Standard for Aircraft Hangars, NFPA 409 - latest revision.

Canada: Refer to Standard CSA B149.1 Natural Gas and Propane Installation Code.

- In aircraft storage and servicing areas, heaters shall be installed at least 10' (3 m) above the upper surface of wings or of engine enclosures of the highest aircraft which may be housed in the hangar. The measurement shall be made from the wing or engine enclosure (whichever is higher from the floor) to the bottom of the heater.

- In shops, offices and other sections of aircraft hangars communicating with aircraft storage or servicing areas, heaters shall be installed not less than 8' (2.4 m) above the floor.

- Suspended or elevated heaters shall be so located in all spaces of aircraft hangars that they shall not be subject to injury by aircraft, cranes, movable scaffolding or other objects. Provisions shall be made to assure accessibility to suspended heaters for recurrent maintenance purposes.

**4.3 Parking Structures and Repair Garages**

Installation in garages must be in accordance with the following codes:

United States: Standard for Parking Structures NFPA 88A - latest revision or the Code for Motor Fuel Dispensing Facilities and Repair Garages, NFPA 30A - latest revision. Canada: Refer to CSA B149.1 Natural Gas and Propane Installation Code.

- In accordance with the Standard for Parking Structures NFPA 88A, heaters must be located a minimum of 18" (50 cm) below the floor-ceiling assembly or 18" (50 cm) above the floor.

- In accordance with the Code for Motor Fuel Dispensing Facilities and Repair Garages, NFPA 30A - latest revision, heaters must not be installed less than 8' (2.4 m) above the floor.

**4.4 Electrical**

The heater must be electrically grounded in accordance with the following codes:

United States: Refer to National Electrical Code®, NFPA 70 - latest revision. Wiring must conform to the most current National Electrical Code®, local ordinances and any special diagrams furnished.

Canada: Refer to Canadian Electrical Code, CSA C22.1 Part 1 - latest revision.

**4.5 Venting**

The venting must be installed in accordance with the requirements within this manual and the following codes:

United States: Refer to NFPA 54/ANSI Z223.1 - latest revision, National Fuel Gas Code.

Canada: Refer to CSA B149.1 Natural Gas and Propane Installation Code.

#### **4.6 High Altitude**

These heaters are CSA-approved (without modifications) for installations up to 2000' (610 m) in US and Canada. CSA approved heaters installed above 2000' (610 m) must be de-rated. For installations above 2000' (610 m) in US, consult factory for information on burner de-rating. For installations from 2000' (610 m) to 4500' (1370m) in Canada, high altitude conversion kits are available. Heaters installed over 4500' (1370 m) in Canada are not CSA-approved and must be approved by the local or provincial authority.

## SECTION 5: DUCT HEATER INSTALLATION

### 5.1 General

To connect the inlet and outlet ducts to the heater, Duct-Mate or similar flanges may be slid over the duct connector flanges supplied on the unit and secured with screws. The connection to the duct then can be made using the Duct-Mate clips. The ducts must have removable access panels upstream and downstream of the heater. These panels must be of appropriate size and placement so that smoke or reflected light could be observed to indicate the presence of leaks in the heat exchanger. Covers for these openings should be sealed to prevent leakage.

Any transition into the inlet of the heater should be smooth, with a taper of no more than 15 degrees. If elbows are required, they should be of either broad radius or fitted with properly designed air turns. Consult a professional to ensure air turns are properly designed.

The heater must be installed on the positive pressure side of the circulating air blower. Air flow through the heater must be as shown on Page 7, Figure 2 and may not be reversed. The air flow must be adjusted such that it is within the acceptable

range shown on Page 7, Section 5.1.3. The minimum inlet duct lengths shown on Page 7, Section 5.1.1 should be observed. Pressure drop through the heat exchanger at various air flows is given on Page 7, Section 5.1.2.

**Figure 2: Air Flow Direction**

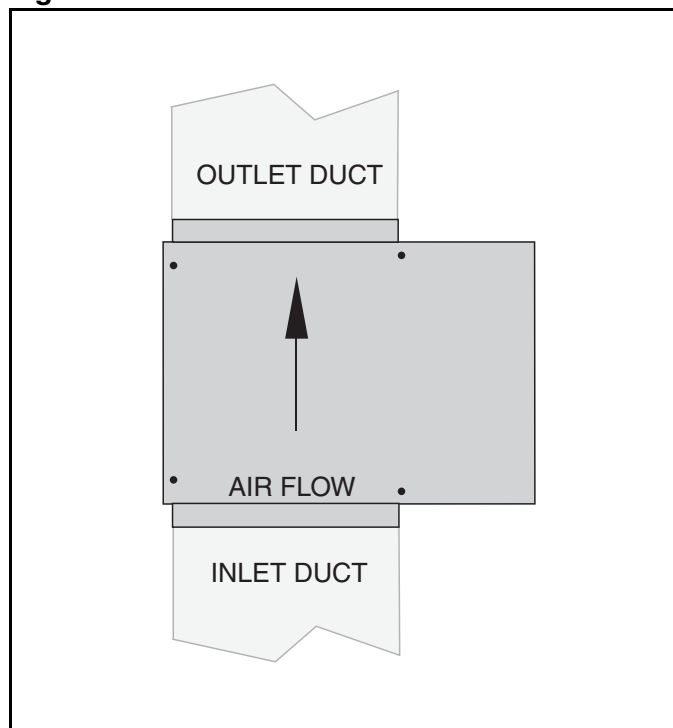

#### 5.1.1 Minimum Inlet Duct Length

Model	Duct Length	Duct Size (W X H)
UHD[X][S][R] 75	32" (81 cm)	16 1/8" x 15 7/8" (41 cm x 40 cm)
UHD[X][S][R] 100 & 125	37" (94 cm)	21 3/4" x 15 7/8" (55 cm x 40 cm)

#### 5.1.2 Temperature Rise and Pressure Drop Ranges

UHD[X][S][R] 75			UHD[X][S][R] 100			UHD[X][S][R] 125		
Airflow (CFM)	Temperature Rise (°F)	Pressure Drop (in wc)	Airflow (CFM)	Temperature Rise (°F)	Pressure Drop (in wc)	Airflow (CFM)	Temperature Rise (°F)	Pressure Drop (in wc)
850	68.0	0.06	950	78	0.05	1,020	92	0.06
1,200	48.3	0.10	1,500	50	0.18	1,650	57	0.14
1,625	36.4	0.16	2,500	31	0.28	2,340	41	0.27
1,965	30.3	0.22	3,000	26	0.39	3,480	28	0.56
2,450	24.4	0.31	3,300	24	0.46	4,240	23	0.80
2,650	22.0	0.36	3,660	22	0.55	4,750	20	0.98

#### 5.1.3 Air Flow and Temperature Rise Ranges

Model	Rate (Btu/h)	Air Flow		Temperature Rise	
		Minimum (CFM)	Maximum (CFM)	Minimum (°F)	Maximum (°F)
UHD[X][S][R] 75	75,000	850	2,650	22	68
UHD[X][S][R] 100	100,000	950	3,660	22	78
UHD[X][S][R] 125	125,000	1,020	4,750	20	92

5.2 Shelf Mounting and Suspension

<b>! WARNING</b>	
	<b>Crush Hazard</b>
	<b>Use 3/8" threaded rod minimum.</b>
	<b>Failure to follow these instructions can result in death, injury or property damage.</b>

Four suspension points (3/8" nuts) are located on the top of the heater. Drop rods must be 3/8" diameter mild steel.

When handling or supporting the heater from below, ensure that the weight is taken at the support points. For typical suspension, See Page 8, Figure 3. For typical shelf mounting on existing shelf, See Page 9, Figure 4.

The gas or electrical supply lines must not be used to support the heater.

Do not locate the gas or electrical supply lines directly over the path of the flue products from the heater.

The heater must be installed in a location that is readily accessible for servicing.

The heater must be installed in accordance with clearances to combustibles as indicated on the wall tag and in this manual.

5.3 Wall Mounting

For typical suspension, See Page 9, Figure 5. Wall mounted heaters blowing parallel to the wall can only be installed with the service door away from the wall.

The wall mounting brackets must be attached to a suitable wall using all mounting holes. Screw sizes less than 3/8" may not be used. In order for the wall mounting brackets to adequately carry the weight of the heater, it must be installed according to best building practices.

Figure 3: Suspension Methods

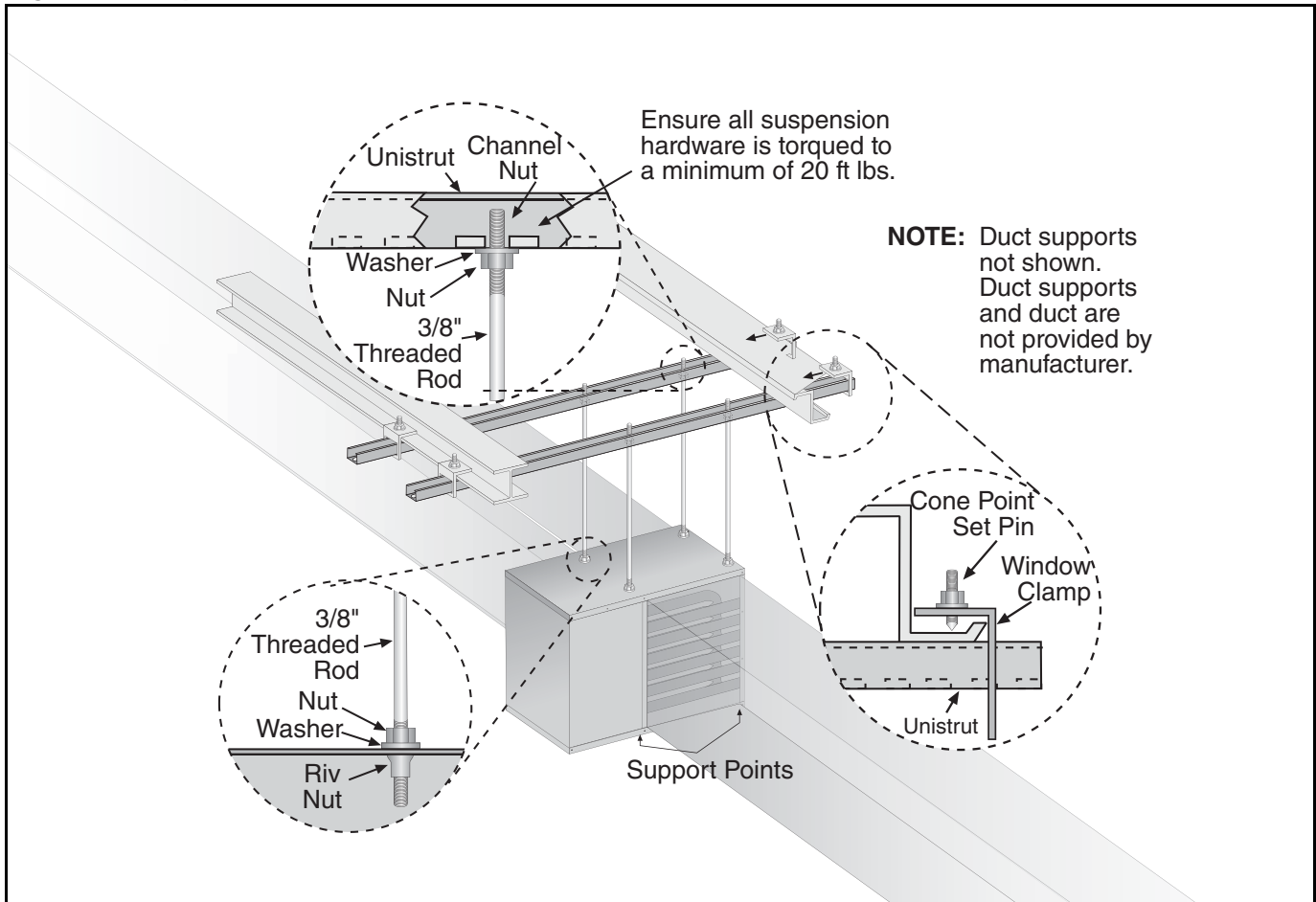
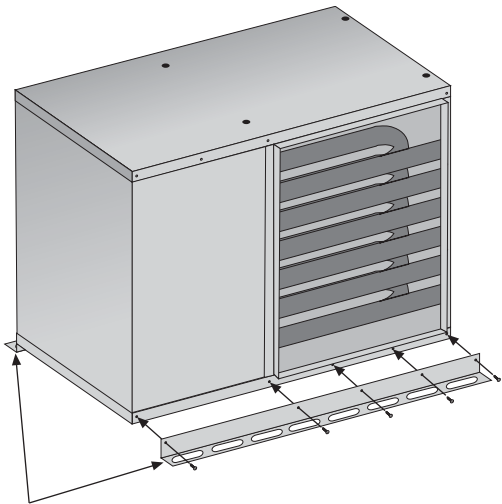

Figure 4: Shelf-Mounting Methods



Shelf Mounting Brackets

Existing cabinet screws must be re-used.

Description	Part Number	Qty.
<b>Shelf Mounting Bracket Kit</b>	<b>12011000K</b>	
Shelf Mounting Bracket	11111510	2
Screw #10 x 1/2" Type AB Phil HWH Z	94311008	2

Figure 5: Wall Shelf Mounting and Suspension

Wall Shelf Mounting

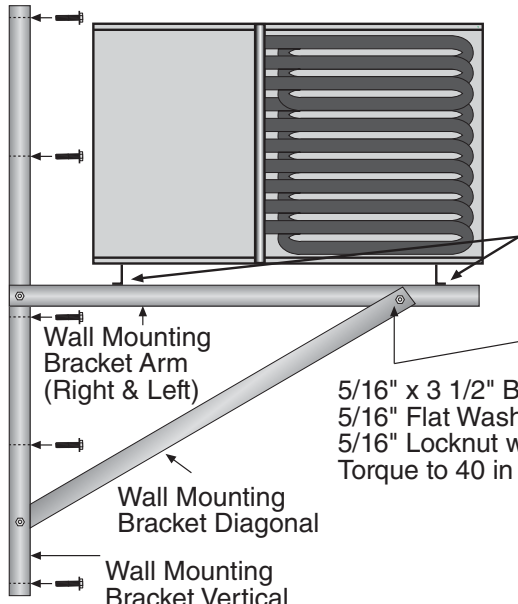

Wall Suspension Mounting

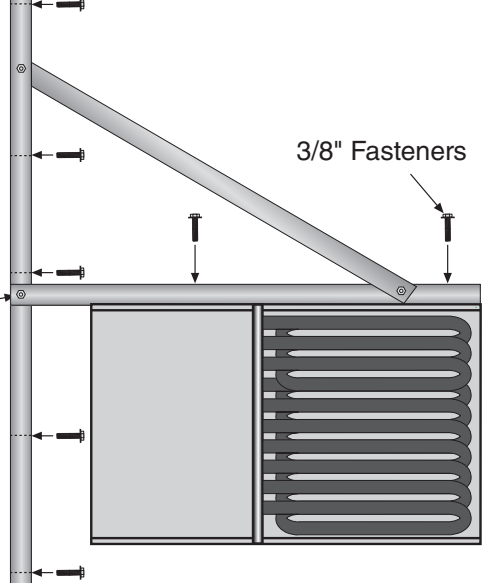

5/16" x 3 1/2" Bolt  
5/16" Flat Washer  
5/16" Locknut with Nylon Insert  
Torque to 40 in lb (4.5 Nm).

Hardware provided to construct mounting bracket assembly only.

Description	Part Number	Qty.
<b>Wall Shelf Mounting Bracket Kit</b>	<b>12011002K</b>	
Wall Suspension Mounting Bracket Kit	12011001K	1
Shelf Mounting Bracket Kit	12011000K	1

Description	Part Number	Qty.
<b>Wall Suspension Mounting Bracket Kit</b>	<b>12011001K</b>	
Wall Mounting Bracket Arm Left	111WALL1	1
Wall Mounting Bracket Arm Right	111WALL1	1
Wall Mounting Bracket Vertical	111WALL2	2
Wall Mounting Bracket Diagonal	111WALL3	2
5/16" x 3 1/2" Bolt	97213925	6
5/16" Lock Nut with Nylon Insert	92114000	6
5/16" Flat Washer	95211600	6
5/16" Lockwasher	96411600	6



**SECTION 6: VENTING**

<b>⚠ WARNING</b>	
	<b>Carbon Monoxide Hazard</b>
	<b>Heaters may be installed vented or unvented.</b>
	<b>Vented heaters must be vented outdoors.</b>
	<b>Unvented heaters must be installed in buildings with ventilation rates as per section 6.4.</b>
<b>Failure to follow these instructions can result in death or injury.</b>	

**6.1 Changing Vent and Air Intake Orientation**

The heater is sold with rear horizontal vent and air intake connections as standard. (Only separated combustion models have air intake connection). If vertical vent and air intake connections are required, follow the instructions *on Page 38, Section 14.5*.

**6.2 Venting**

This heater must be vented in accordance with the rules contained in this manual and with the following national codes and any state, provincial or local codes which may apply: **United States:** Refer to NFPA54/ANSI Z223.1 - latest revision, National Fuel Gas Code; **Canada:** Refer to CSA B149.1 Natural Gas and Propane Installation Code.

Any portion of vent pipe passing through a combustible wall must have a listed thimble to conform with the above codes.

The heater may be installed unvented in certain circumstances according to building ventilation codes. Refer to the above codes *and Page 11, Section 6.4* for further information.

Unvented operation also requires compliance with the clearances to combustibles given *on Page 3, Figure 1*.

The bottom of the vent or air intake terminal shall not be located less than 1' (.3 m) above grade level.

The vent shall not terminate less than 7' (2.1 m) above grade where located adjacent to public walkways.

Vent terminal must be installed at a height sufficient to prevent blockage by snow and building materials protected from degradation by flue gasses.

Vent terminal must be beyond any combustible overhang.

Secure all joints with corrosion resistant #8 x 3/8"

sheet metal screws.

For single wall venting, pressure sensitive aluminum tape or silicone sealant must be used to seal all joints.

Aluminum tape shall have a minimum temperature rating of 400° F (204° C) and meet SMACNA AFTS-100-73 standards. High temperature silicone sealant must have a minimum temperature rating of 480° F (250° C).

**6.2.1 United States Requirements**

Vent must terminate at least 3' (.9 m) above any forced air inlet located within 10' (3.1 m).

Vent must terminate at least 4' (1.2 m) below, 4' (1.2 m) horizontally from, or 1' (.3 m) above any door, operable window, or gravity air inlet into any building.

NFPA 54/ANSI Z223.1 - latest revision, National Fuel Gas Code specifies a 4' (1.2 m) horizontal vent terminal clearance from gas and electric meters, regulators and relief equipment.

**6.2.2 Canadian Requirements**

The vent shall not terminate within 6' (1.8 m) of a mechanical air supply inlet to any building.

The vent shall not terminate within 3' (.9 m) of a window or door that can be opened in any building, any non-mechanical air supply inlet to any building, or of the combustion air inlet of any other appliance.

**6.3 Vent Installation**

Maintain clearances to combustibles at all times for safety. Clearances are the required distances that combustible objects must be away from the heater to prevent serious fire hazard. *See Page 3, Figure 3.5*. For vented units, the vent must terminate outside of the building.

Vents must be fully sealed and correctly sized for the model. If the vent passes through a wall or ceiling of combustible material, it must be enclosed by a listed thimble and be separated from the thimble by at least a 2" (5 cm) air gap.

For separated combustion models, vents and air intakes must be a fully sealed system and correctly sized for the model. Vent should be assembled as detailed *on Page 13, Figure 6 through Page 16, Figure 11*. The joints between the vent terminal and the roof or wall must be properly sealed. If the vent passes through a wall or ceiling of combustible material, it must be enclosed by a listed thimble and be separated from the thimble by at least a 2" (5 cm) air gap.



**Vents and air intakes must be adequately supported so that the heater does not bear the weight of the pipes.**

For vent termination See Page 13, Figure 6 through Page 16, Figure 11.

**6.3.1 Standard Vented Heaters  
(Models UHD[X][R] 75 - 125)**

The vent must be fitted with a low resistance terminal. See Page 13, Figure 6 through Page 13, Figure 7. Standard vented heaters do not allow outdoor air intake for combustion air.

**6.3.2 Separated Combustion Heaters  
(Models UHD[X]S[R] 75 - 125)**

The heaters are designed to be installed as separated combustion heaters. The vent and air intake are run as separate pipes to the wall or roof terminals. See Page 15, Figure 9. As an option, the vent and air intake are run as separate pipes to a concentric vent box and a concentric vent/air intake pipe penetrates the wall or roof. See Page 15, Figure 10 and See Page 16, Figure 11.

For separated combustion installation, the vent and air intake must be fitted with an individual and correctly sized sealed system and the vent and air intake must terminate at approved wall and roof terminals.

Separated combustion units may not be common vented. See Page 10, Section 6.

**6.4 Unvented Operation**

<b>⚠ WARNING</b>	
	<p><b>Carbon Monoxide Hazard</b></p> <p><b>Heaters may be installed vented or unvented.</b></p> <p><b>Vented heaters must be vented outdoors.</b></p> <p><b>Unvented heaters must be installed in buildings with ventilation rates as per section 6.4.</b></p> <p><b>Failure to follow these instructions can result in death or injury.</b></p>

This heater is not approved to be installed in residential buildings.

For unvented operation in commercial installations, sufficient building ventilation must be provided in the amount of 4 cfm per 1000 Btu/h firing rate (United

States); 3 cfm per 1000 Btu/h firing rate (Canada).

**WARNING:** Combustion by-products contain a chemical known to the State of California to cause cancer and birth defects or other reproductive harm.

**6.5 Horizontal Venting**

Horizontally vented heaters must be individually vented.

Vent pipe must be sloped ¼" (.6 cm) downward for every 1' (.3 m). For vent lengths greater than 5' (1.5 m), condensation will form. Insulation is recommended and condensation drains may be desired.

In noncombustible walls only, vent terminal (P/N 02537801-1P) may be used.

For 4" (10 cm) vents in either combustible or noncombustible walls, use vent terminal (P/N 90502100) or equivalent insulated vent terminal. Follow the manufacturer's instructions for proper installation.

Instead of an insulated vent terminal, a listed thimble (with 2" (5 cm) air gap) may be used with a 4" (10 cm) vent cap (P/N 90502102).

**6.6 Vertical Venting**

Vertically-vented standard-vented heaters can be common vented (up to four heaters).

For vent lengths greater than 5' (1.5 m), condensation will form. Insulation is recommended and condensation drains may be desired. Venting through the top of the heater cabinet is not recommended if vent lengths are longer than 10' (3 m). In this case, vent from the rear of the heater cabinet then run the vent vertically and use a condensate drain at the bottom of the vertical vent. Vent pipe must be sloped 1/4" (.6 cm) for every 1' (.3 m).

For 4" (10 cm), an approved vent cap (P/N 90502102) must be used.

For 6" (15 cm) common vent, an approved vent cap (P/N 90502103) must be used.

For common vertical venting of more than two heaters, See Page 14, Figure 8.

A vent shall not extend less than 2' (.6m) above the highest point where it passes through a flat roof of a building.

**6.7 Length Requirements**

If using vent lengths greater than 5' (1.5 m), condensation will form in the vent pipe. Insulation

and additional sealing measures (high temperature silicone at all seams) are required.

The entire vent should be insulated with foil faced fiberglass insulation (1/2" thick, 1-1/2# density minimum).

**6.7.1 Maximum Vent Lengths**

Model UHD[X][S][R] 75, 100, 125	Number of Elbows
40 ft (12.2 m)	1
35 ft (10.7 m)	2
30 ft (9.1 m)	3
25 ft (7.6 m)	4
20 ft (6.1 m)	5

**6.8 Vent Material**

Vent material may be single wall 26 ga. (minimum) galvanized steel or equal thickness stainless steel. Completely seal all joints, refer to *Page 10, Section 6.3*.

If penetrating a combustible wall or roof, a listed thimble with 2" (5 cm) clearance must be used. Where local codes permit, a single section of type B-1 vent material may be used at the roof or wall penetration instead of a thimble. Ensure vent manufacturer's clearance from vent material is maintained. Seal annular space of the type B-1 vent as well as all joints in the remaining vent.

**6.9 Replacing an Existing Heater in a Venting System**

When replacing an existing heater in a venting system, the venting system may not be properly sized to vent the new heater. The following steps must be followed with each appliance connected to the venting system placed in operation, while any other appliances connected to the venting system are not in operation.

1. Seal any unused openings in the venting system.
2. Inspect the venting system for proper size and horizontal pitch, as required by the NFPA 54/ANSI Z223.1 - latest revision, National Fuel Gas Code (US) or Standard CSA B149.1 Natural Gas and Propane Installation Code (Canada) and these instructions. Determine that there is no blockage or restriction, leakage, corrosion and other deficiencies which could cause an unsafe condition.
3. Close all building doors and windows and all doors between the space in which the appliance(s) connected to the venting system are located and other spaces of the building. Turn on clothes dryers and any exhaust fans, such as range hoods and bathroom exhausts so that they shall operate at maximum speed.

Do not operate a summer exhaust fan. Close fireplace dampers.

4. Follow the lighting instructions. Place the appliance being inspected in operation. Adjust thermostat so that the appliance will operate continuously.
5. For any appliance having a draft hood, test for draft hood appliance spillage at the draft hood relief opening after five minutes of main burner operation. Use the flame of a match or candle.
6. After it has been determined that each appliance connected to the venting system properly vents when tested as outlined above, return doors, windows, exhaust fans, fireplace dampers and any other gas-burning appliances to their previous conditions of use.
7. If improper venting is observed during any of the above tests, the venting system must be corrected by a contractor qualified in the installation and service of gas-fired equipment or your local gas supplier. If the venting must be resized, use appropriate tables in (US) Appendix G of NFPA 54/ANSI Z223.1 - latest revision, National Fuel Gas Code (US) or Standard CSA B149.1 Natural Gas and Propane Installation Code (Canada) to determine minimum size. All vent corrections must be in accordance with the appropriate local codes and the NFPA 54/ANSI Z223.1 - latest revision, National Fuel Gas Code (US) or Standard CSA B149.1 Natural Gas and Propane Installation Code (Canada).

**Figure 6: Vent and Roof Detail**

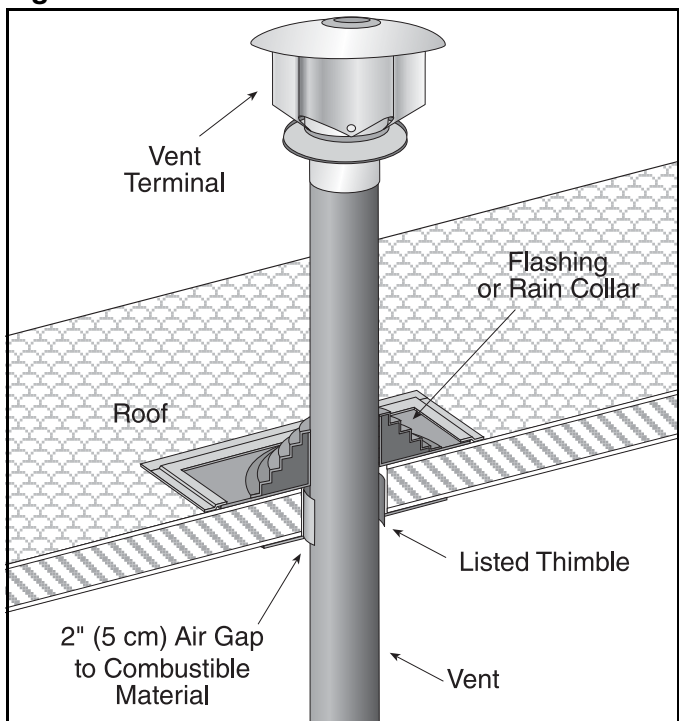

**Figure 7: Standard Vented Heater - Vertical and Horizontal Vent Termination**

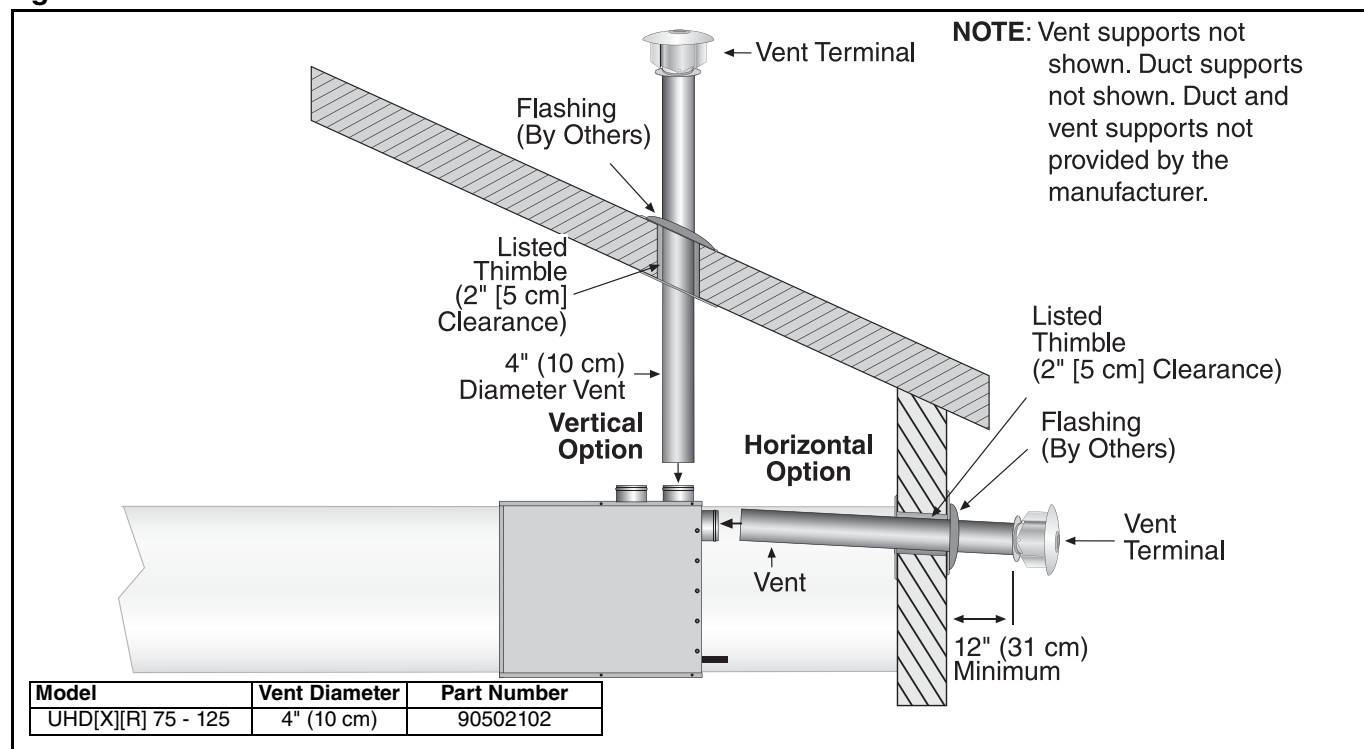

**Figure 8: Standard Vented Heater - Common Vertical Vent Termination**

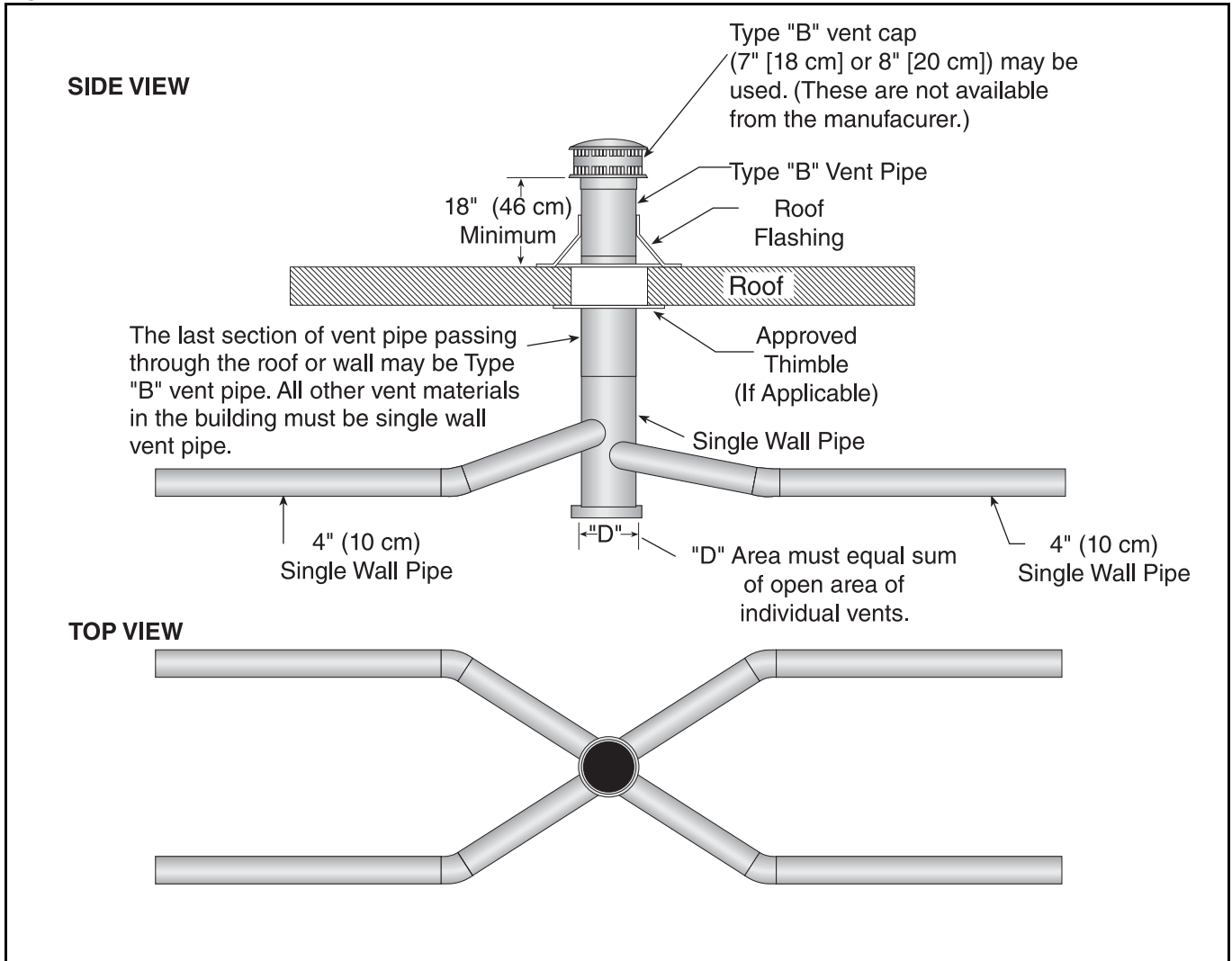

**Figure 9: Separated Combustion Heater - Vertical and Horizontal Vent Termination**

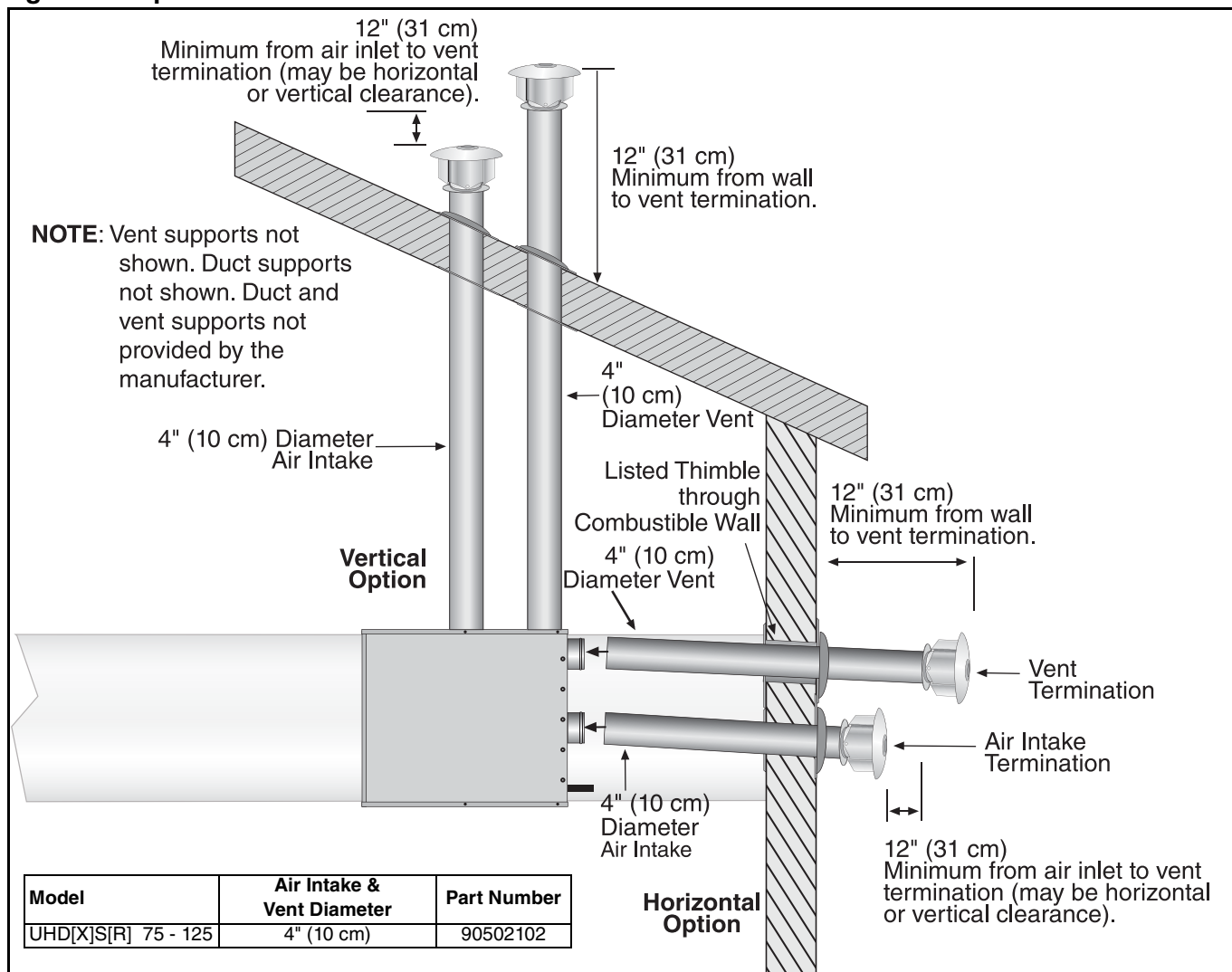

**Figure 10: Concentric Vent Box**

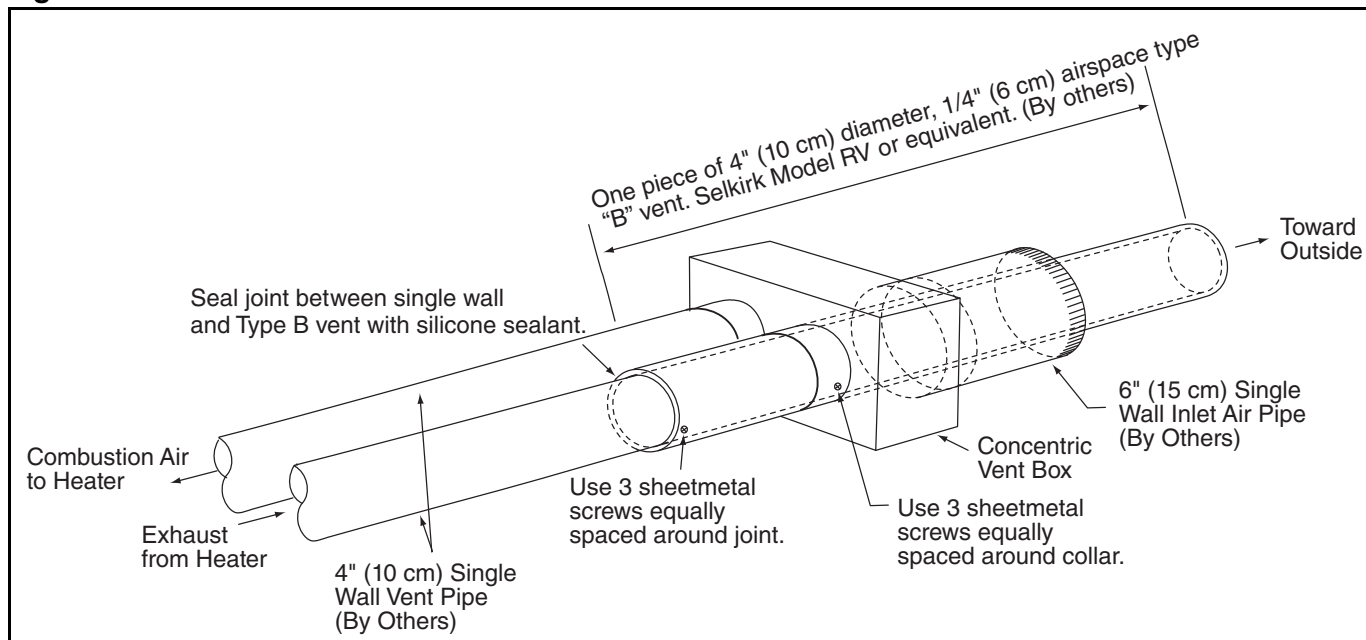

**Figure 11: Concentric Vertical and Horizontal Vent Termination - Separated Combustion Heater**

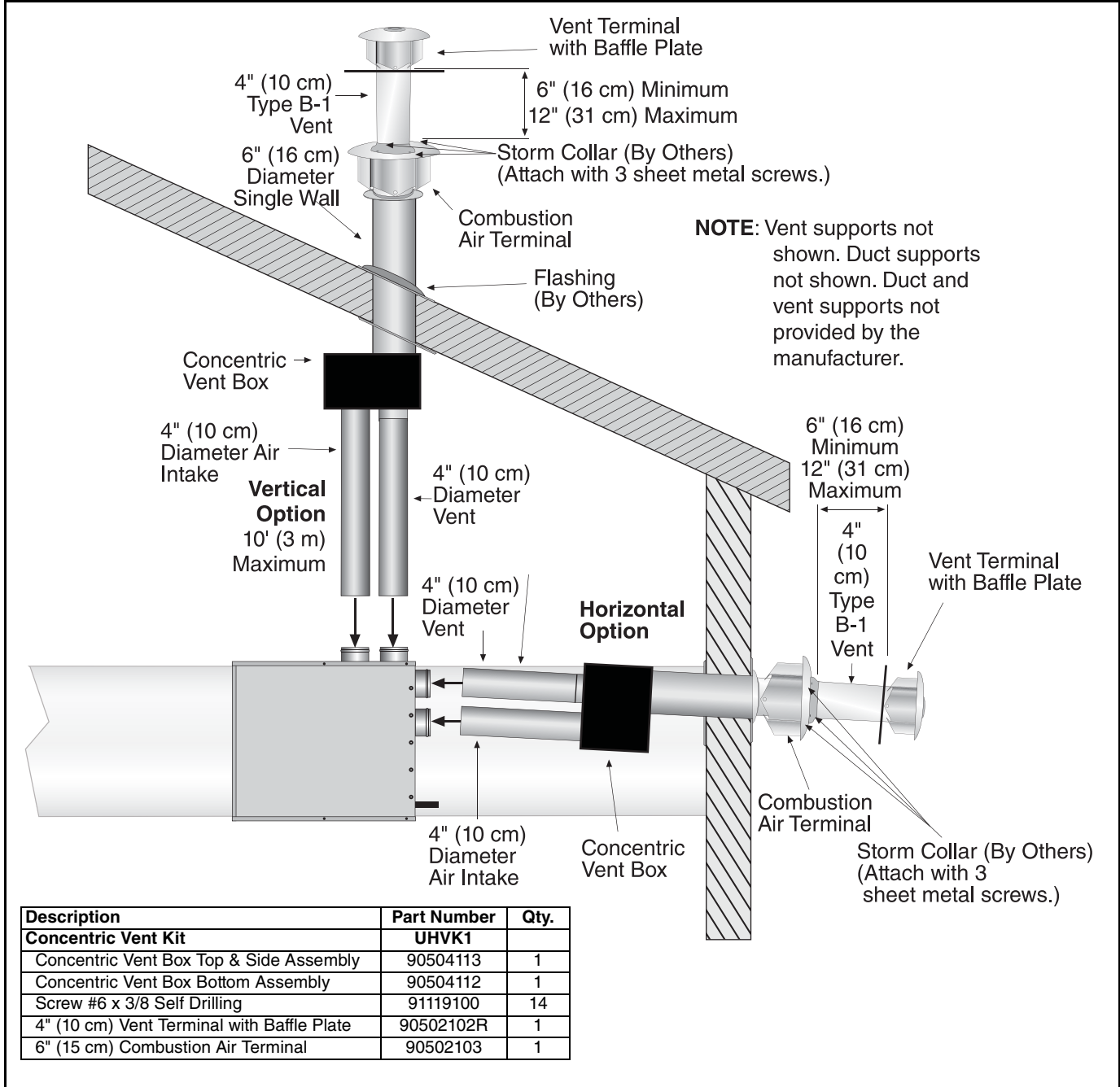

Description	Part Number	Qty.
<b>Concentric Vent Kit</b>	<b>UHVK1</b>	
Concentric Vent Box Top & Side Assembly	90504113	1
Concentric Vent Box Bottom Assembly	90504112	1
Screw #6 x 3/8 Self Drilling	91119100	14
4" (10 cm) Vent Terminal with Baffle Plate	90502102R	1
6" (15 cm) Combustion Air Terminal	90502103	1

## SECTION 7: AIR SUPPLY

### 7.1 Separated Combustion Installation

When installed as a separated combustion heater (UHD[X]S[R]), the air for combustion is drawn in from outside the building.

### 7.2 Unvented Installation

It is important to ensure that there is adequate fresh air supply at all times for both combustion and heating requirements in accordance with local and national codes.

**WARNING:** Combustion by-products contain a chemical known to the State of California to cause cancer and birth defects or other reproductive harm.

### 7.3 Building Ventilation

Where ventilation is required, air must be taken from an outside point where it is not likely to be contaminated or obstructed.

### 7.4 Outside Combustion Air Supply

If outside combustion air supply is required, separated combustion model (UHD[X]S[R]) heaters must be used.

**Caution:** If the building has a slight negative pressure or corrosive contaminants such as halogenated hydrocarbons are present in the air, an outside combustion air supply to the heater is required. Seal all combustion air pipe joints. The flexible air supply duct may have to be insulated to prevent condensation on the outer surface. The outside air terminal must not be more than 1' (31 cm) above the vent terminal.

#### 7.4.1 Length Requirements

Follow the constraints listed *on Page 11, Section 6.7.*

**SECTION 8: GAS PIPING**

⚠ **WARNING**



**Fire Hazard**

**Connect gas supply according to Figure 12.**

**Do not use gas supply pipe and electrical connections to support the heater's weight.**

**Gas can leak if not installed properly.**

**Failure to follow these instructions can result in death, injury or property damage.**

- Gas supply pipe work is run in medium or heavy gauge tubing in compliance with local and national codes.
- Meter and service must be large enough to handle all the burners being installed plus any other connected load. The gas pipe which feeds the system must be large enough to supply the required gas with a maximum pressure drop of 1/2" wc. When gas piping is not included in the layout drawing, contact the local gas supplier.
- An isolating valve and union connection should be used and fitted into the supply adjacent to the heater.
- A minimum 1/8" NPT plugged tapping accessible for test connection must be installed immediately upstream of the gas supply connection to the heater.
- For suspended heaters, an approved metal flexible connection between the isolating valve and the heater may be used. **To reduce pressure loss, use one pipe size larger than the heater gas connection.**

A gas meter is connected to the service pipe by the gas supply company. An existing meter should be checked, preferably by the company, to ensure that the meter is adequate for the rate of gas supply required.

Installation pipes must be fitted in accordance with local and national codes. Pipes of smaller size than the heater inlet gas connection should not be used.

**8.1 Connections**

Connect the heater to the gas supply ensuring that the final connections are as follows:

**IMPORTANT** - The complete installation must be purged and tested for gas soundness in accordance with local and national codes.

**Caution:** Do not high pressure (in excess of 1/2 psi [14" wc]) test the gas piping with the burner connected. Close manual shut-off valve during any pressure testing equal to or less than 1/2 psi (14" wc).

**Check the pipe and tubing ends for leaks before placing heating equipment into service. When checking for gas leaks, use a soap and water solution; never use an open flame.**

**Figure 12: Gas Connection**

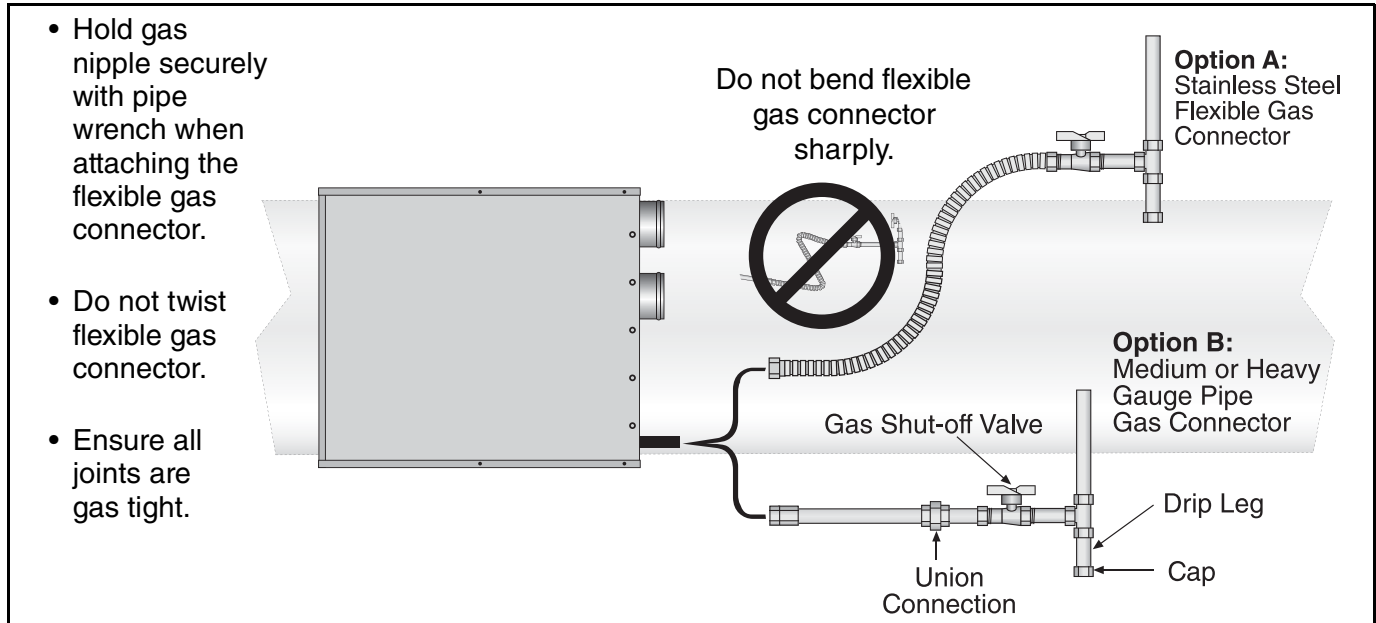



## SECTION 9: WIRING

**⚠ WARNING****Electrical Shock Hazard**

**Disconnect electrical and gas supply before servicing.**

**This appliance must be connected to a properly grounded electrical source.**

**Failure to follow these instructions can result in death or electrical shock.**

All heater models require constant 120 V/1Ø/ 60 Hz power supply. Check heater rating plate for electrical rating for proper circuit sizing. For servicing, a disconnect switch of proper electrical rating should be installed in the vicinity of the heater.

All heaters are equipped with thermostat connections suitable to power a 24 V thermostat. Heater must be wired and electrically grounded in accordance with local codes. In the absence of local codes in accordance with: United States: refer to National Electrical Code® NFPA 70 - latest revision; Canada: refer to Canadian Electrical Code CSA C22.1 Part I - latest revision.

**9.1 Positioning Thermostats**

A room thermostat should be mounted on a vibration-free wall or column at a height of approximately 5' (1.5 m) from the floor to measure the ambient temperature. It should be clear of both cold drafts and the direct path of warm air from the heater.

Avoid mounting thermostat on outside walls or in areas directly exposed to radiant heat or sunlight. Install wall tag in a visible location near thermostat. See Page 2, Section 2.1 for wall tag details.

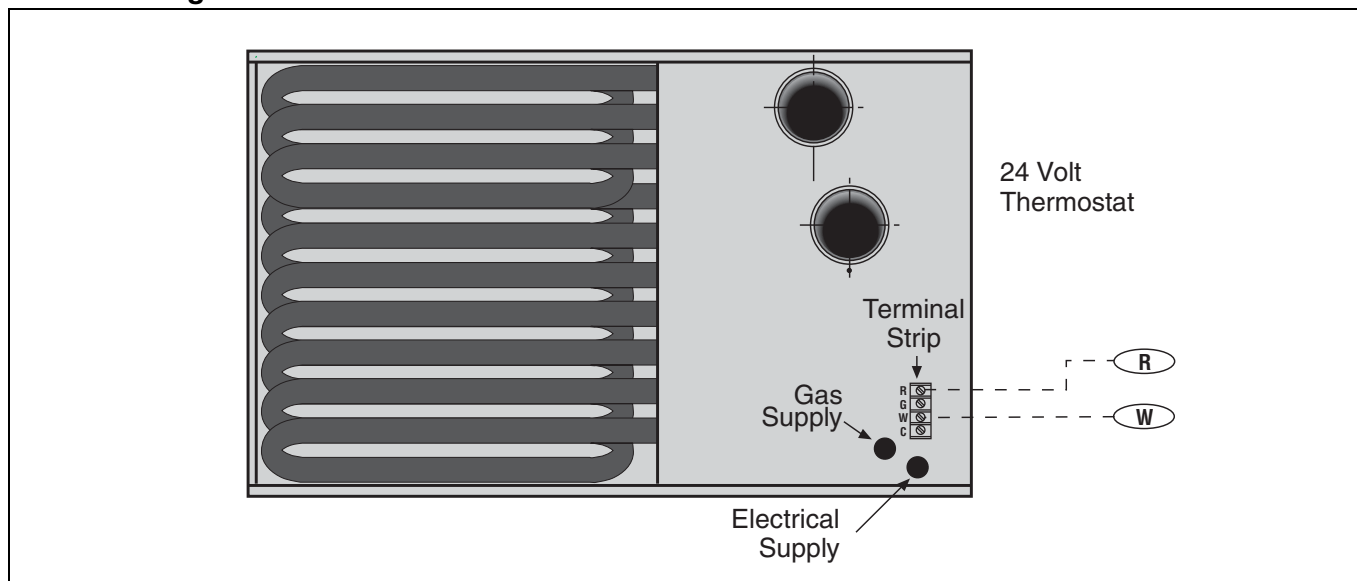
**9.2 Low Voltage Thermostat with One Heater**

### 9.3 Internal Wiring Diagram

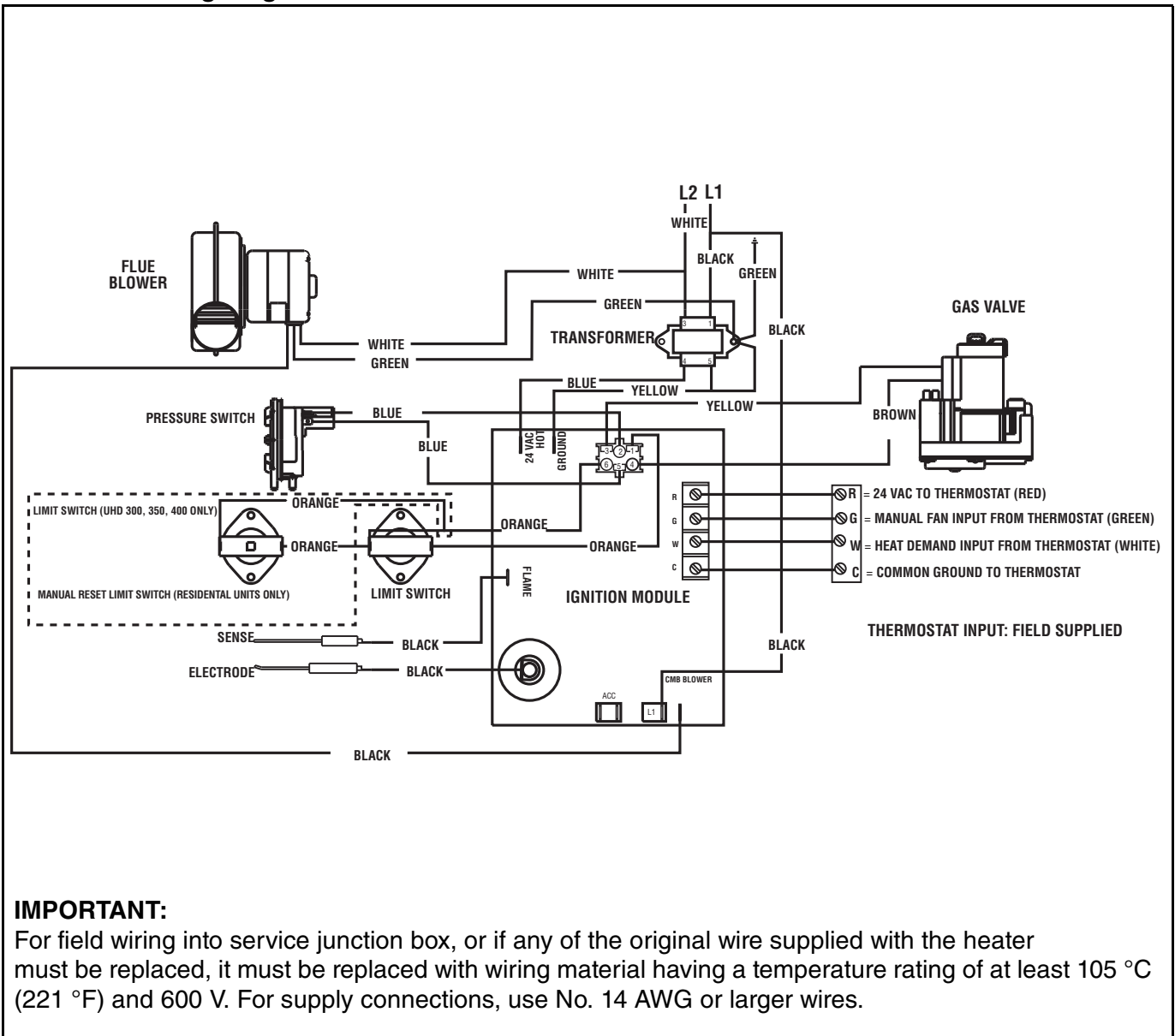

## 9.4 Ladder Wiring Diagram

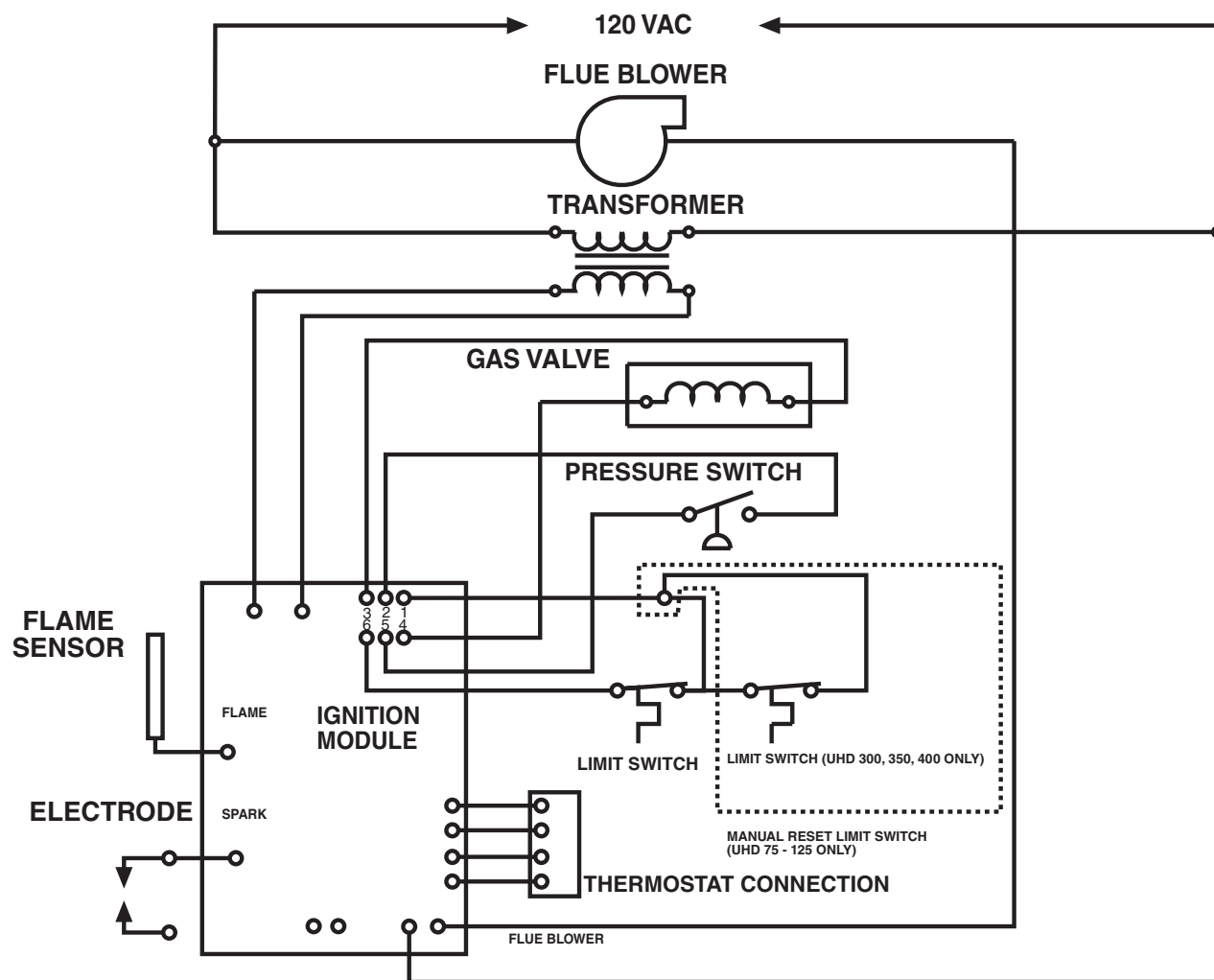
**IMPORTANT:**

For field wiring into service junction box, or if any of the original wire supplied with the heater must be replaced, it must be replaced with wiring material having a temperature rating of at least 105 °C (221 °F) and 600 V. For supply connections, use No. 14 AWG or larger wires.

### 9.5 Electrical Connection to the Heater

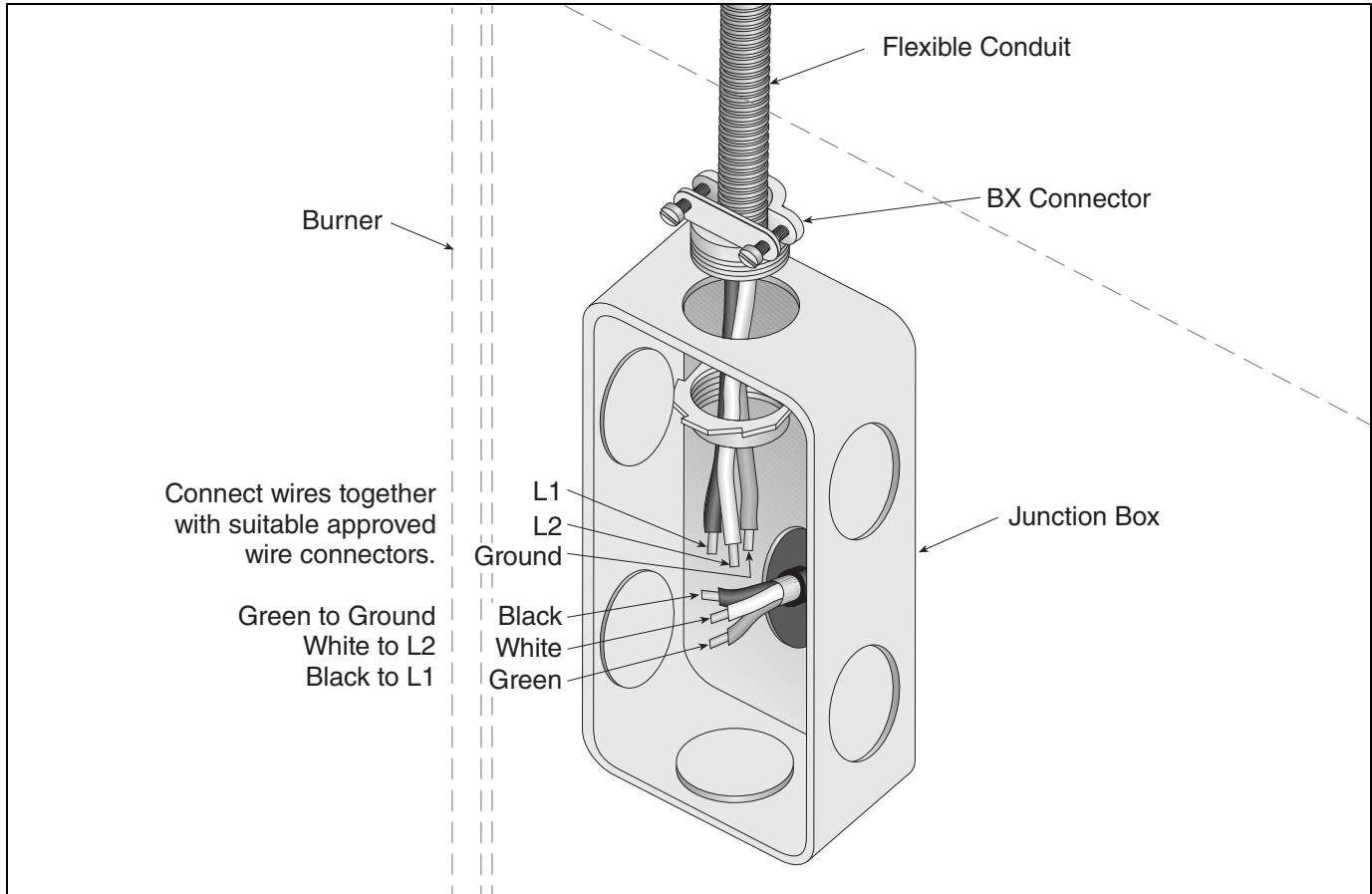

**IMPORTANT:** Junction box is not provided with heater.  
Conduit can also be attached directly to heater with wire junction made within the heater cabinet.

## SECTION 10: OPERATION AND MAINTENANCE



Read this manual carefully before installation, operation, or service of this equipment. All components are accessed via the door secured by four sheet metal screws. Opening the door exposes live electrical connections and hot components.

### 10.1 Pre-Start-Up Checks

All pre-start-up checks must be carried out before lighting the heater.

Ensure that the heater and all controls are suitable for the gas, pressure and electrical supply to which they are to be connected.

#### 10.1.1 Electrical Checks

1. Check that all site wiring is connected in accordance with the appropriate wiring diagram on Page 20, Section 9.3.

#### 10.1.2 Gas Supply

All aspects of the gas installation including the gas meter must be inspected, tested for gas tightness and purged in accordance with local and national codes.

Ensure that the air is fully purged from the heater inlet pipe up to the main gas valve inlet test nipple.

#### 10.1.3 Mechanical Checks

1. Check that the flue (and air intake for separated combustion units) is installed in accordance with these instructions and local regulations.

## 10.2 Begin Start-Up

### 10.2.1 Before Operating the Heater

To ensure that all the controls are in safe working order, operate the heater for the first time with the isolating gas valve turned off and power supply turned on.

1. Turn off the isolating gas valve.
2. Turn up the thermostat above room temperature. The automatic ignition sequence will now begin as described on Page 24, Figure 13.

There will be no ignition of the burner and lockout will occur, which proves the controls are operating correctly.

**Figure 13: Automatic Burner Control Sequence**

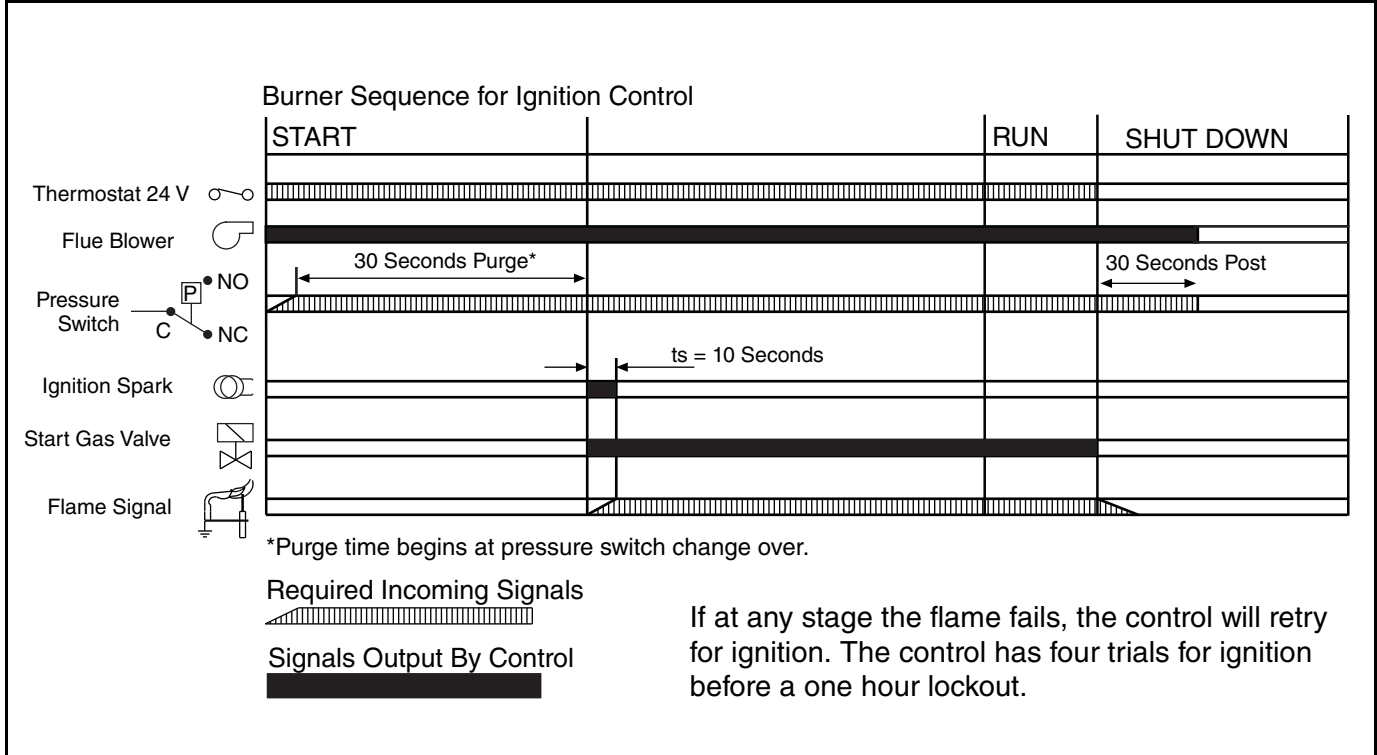

**Figure 14: Gas Valve**

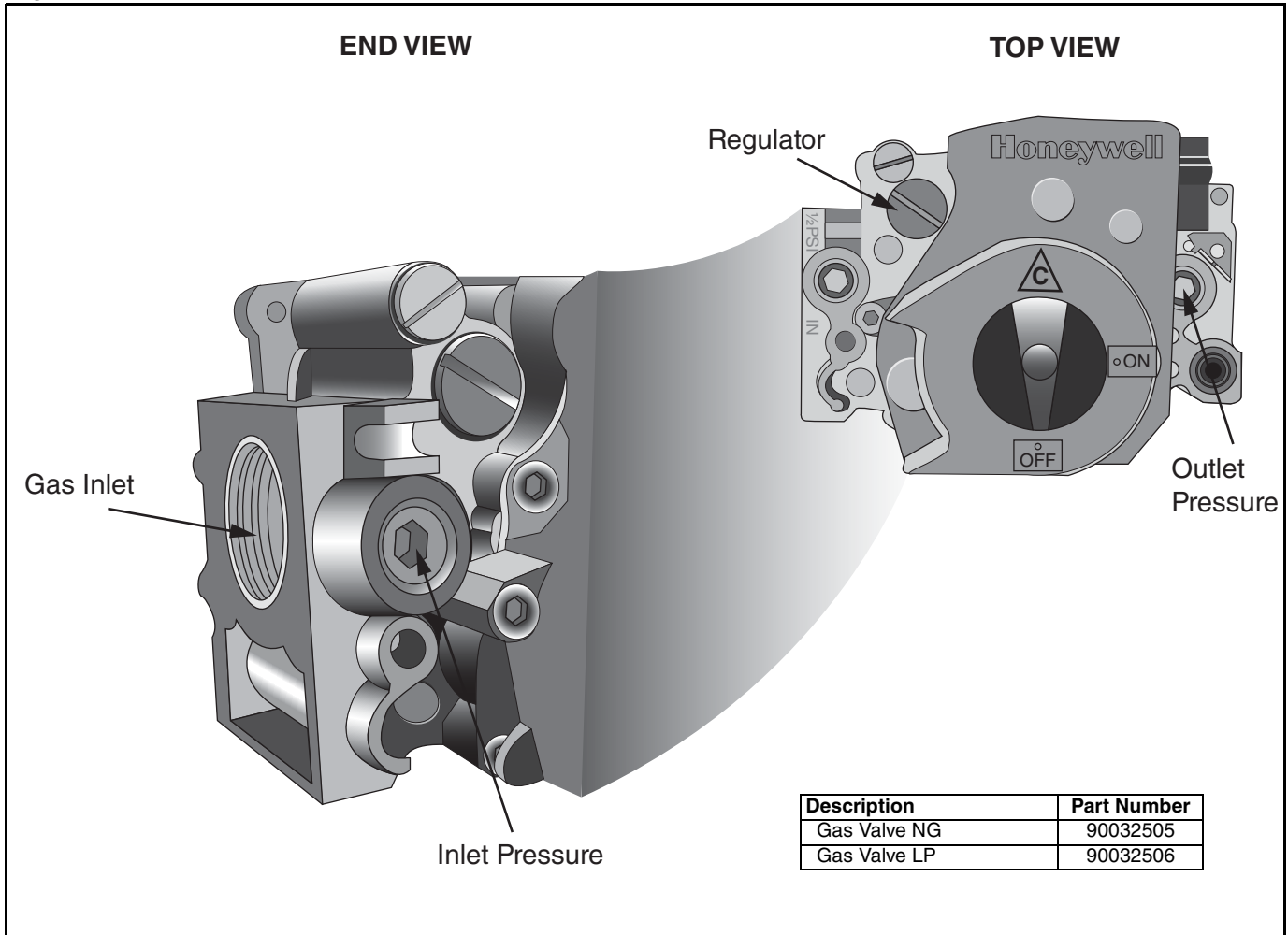

## 10.2.2 Start-Up the Gas Valve (All Gases)

### 10.2.2.1 Check Burner Gas Pressure

1. Remove the plug in the outlet (burner) pressure test point and connect a pressure tap and a manometer.
2. With the burner firing, measure the pressure on the manometer. To adjust the burner pressure, remove the regulator cover from the valve and turn the regulator adjustment screw to set the required burner pressure as stated in the Technical Data Tables for the correct gas and model *on Page 41, Section 15.3*.

**IMPORTANT:** If the correct burner pressure cannot be reached, then check the inlet pressure to the valve with the burner firing. See Technical Data Tables *on Page 41, Section 15.3* for inlet pressure requirement.

**Do not continue to adjust the regulator if the pressure is not changing.**

If the inlet pressure is too low to allow correct burner pressure setting, then the gas inlet pressure must be corrected before completing the start-up.

### Check Gas Rate

1. After burner pressure adjustment, allow the heater to operate for at least 15 minutes and then re-check settings. Adjust pressure setting if necessary.
2. Check gas flow rate at gas meter.
3. Turn off heater and electrical supply.
4. Remove the manometer and refit all covers to the valve and tighten the screw of the outlet pressure tap.

### 10.2.3 Pressure Switch

The pressure switch is factory pre-set for each model and is not adjustable.

### 10.2.4 Turning Off the Heater

Set the thermostat to the "OFF" position or lowest setting and the main burner will stop.

### 10.2.5 External Controls

External controls may include time switch, interlock switch, room thermostat and frost thermostat. Operate each control to ensure that they function correctly. Set the switches (if fitted) and thermostat(s) to the users' requirements.

## 10.3 Complete Start-Up

Ensure that all covers are fitted correctly and all test points are properly sealed.

### 10.3.1 Instruction to the User

Explain the controls of the heater to the user including how to turn it on and off, using the controls fitted on site.

Give this manual to the user.

Ensure that the user is shown and understands the importance of maintaining clearances to combustibles *on Page 3, Figure 1* and the user instructions *on Page 26, Section 11 through Page 27, Section 11.5* and all warnings defined in this manual.

**SECTION 11: USER INSTRUCTIONS**

**⚠ WARNING**





**Explosion Hazard**

Installation, service and annual inspection must be done by a contractor qualified in the installation and service of gas-fired heating equipment or your gas supplier.

Turn off gas and electrical supplies before performing service or maintenance.

Failure to follow these instructions can result in death, injury or property damage.

**11.1 User Instructions**

The UHD[X][S][R] Series heaters are fully automatic and operate from the external controls fitted on site. The only user control at the heater is the Manual Reset Limit Switch - See Page 26, Section 11.3.1

**11.2 Heater Operation**

When the heater has been switched on by the thermostat installed on site, the main burner will automatically turn on. The burner control box will control the safe ignition of the flame. All heaters require a constant gas and electricity supply which must not be interrupted during the normal operation of this heater.

**11.3 Common User Controls**

**11.3.1 Manual Reset Limit Switch**

**⚠ WARNING**



**Explosion Hazard**

Do not make more than one attempt to restart the heater if manual reset limit switch locks out.

The vent or heat exchanger may be blocked.

The fault must be traced and repaired.

Failure to follow these instructions can result in death, injury or property damage.

The limit thermostat is located inside the access door of the heater. See Page 37, Section 14.3. This control protects against excessive heat build-up inside the burner compartment.

**Figure 15: Manual Reset Limit Switch**

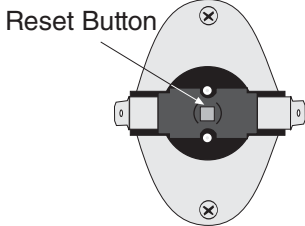

To reset manual reset limit switch, press reset button. **NOTE:** To reset, the switch must be cool.

Description	Part Number
Manual Reset Limit Switch	90412106

**11.4 Lighting Instructions**

**11.4.1 To Turn On Heater**

1. Ensure that the electrical and gas supplies to the heater are on. Check that the on site controls are "ON".

**IMPORTANT:** The thermostat setting must be above the ambient temperature for the heater to operate.

2. The automatic firing sequence will begin as described on Page 24, Figure 13. The heater will now operate automatically under the control of the on site controls.



### 11.4.2 To Turn Heater Off

Set the thermostat to the "OFF" position.

The burner will turn off immediately.

To restart, turn the thermostat above room temperature.

### 11.5 Simple Troubleshooting

Some possible reasons for the heater not operating are:

1. Gas supply not "ON".
2. Electricity supply not "ON".
3. The time and/or temperature controls are not "ON".
4. A limit switch may have operated. This may be caused by an interruption of the electrical supply, failure of the distribution fan or vent or heat exchanger blockage.

If a temperature limit switch persistently trips, there is a fault which must be investigated by a contractor qualified in the installation and service of gas-fired heating equipment.

#### 11.5.1 Simple Troubleshooting (Burner Faults)

If the burner fails to ignite for any reason, it will retry for ignition (four trials total). After four unsuccessful ignition trials, the control will put the heater into lockout for one hour.

Lockout should not occur during normal operation of the heater and indicates there is a fault condition which must be corrected. There is an LED light on the ignition control that flashes codes to assist in fault correction. See *Page 27, Figure 16* for LED indication codes.

**Figure 16: LED Diagnostic Codes**

LED INDICATION	FAULT MODE
Slow Flash	Normal Operation - No call for heat.
Fast Flash	Normal Operation - Call for heat.
2 Flashes	Ignition Lockout - No flame detected.
3 Flashes	Airflow Fault - Pressure switch open or closed.
4 Flashes	Temperature Limit or Manual Reset Limit Switch Open
5 Flashes	Flame Sense Error - Gas valve not energized.
Steady On	Internal Control Failure

**SECTION 12: SERVICING**

<b>! WARNING</b>		
		
<b>Explosion Hazard</b>		
<p><b>Installation, service and annual inspection must be done by a contractor qualified in the installation and service of gas-fired heating equipment or your gas supplier.</b></p> <p><b>Turn off gas and electrical supplies before performing service or maintenance.</b></p> <p><b>Failure to follow these instructions can result in death, injury or property damage.</b></p>		

**12.1 Servicing Instructions**

After start-up, the heater will require maintenance to be carried out annually. If the heater is used in a dirty or dusty area, more frequent maintenance may be required.

**IMPORTANT:** After any maintenance or repair work, always test fire the heater in accordance with the start-up instructions on *Page 23, Section 10 through Page 25, Section 10.3.1* to ensure all safety systems are in working order before leaving the heater to operate. Minor faults may be traced by using the troubleshooting charts on *Page 31, Section 13 through Page 34, Section 13.5*.

**IMPORTANT:** Check all gas pipes and pipe joints to ensure there are no cracks or gas leaks. Any cracks in the pipes or pipe joints must be repaired.

**IMPORTANT:** Inspect all suspended components and hardware. Ensure that they are in good condition, properly tightened, and corrosion free.

**12.2 Burner Maintenance**

1. Open the door and remove the burner compartment cover. See *Page 36, Section 14.2*.
2. Clean any deposits from the main burner which may have formed in the injectors or venturi of the burner. See *Page 36, Section 14.2*.

3. Remove the ignition electrode and flame probe. Check condition of ignition electrode and flame probe. Clean off any deposits which may have been formed, check condition of ceramic insulators. Replace as required.

**12.3 Heat Exchanger Maintenance**

The heat exchanger will remain clean unless a problem has developed with combustion. Inspect the heat exchanger. Look for signs of overheating at the front tubes which may indicate burner over firing or persistently low air flows.

**12.4 Gas Valve Maintenance**

No regular maintenance is required on this device. To change gas control valves, See *Page 35, Section 14.1*.

**Do not repair or disassemble gas valve.**

Replace faulty gas valves with replacement parts sold and supplied by Roberts-Gordon.

**12.5 Flue Blower**

The flue blower should not require maintenance. However, if the air pressure switch is causing burner lockout, then remove the flue blower from the vent box by unscrewing the three screws at the mounting plate. Remove the four screws attaching the mounting plate to the fan inlet (See *Page 38, Section 14.5*). Ensure that the fan is free to run and that the fan wheel is clean.

**12.6 Venting and Air Intake Pipe**

Inspect all venting and air intake pipe. Ensure that all seams are sealed and suspension points secure. Repair suspension points if any part of the venting or combustion air pipe is sagging. Check to make sure any insulation is not missing or in poor condition. Replace as required. Check all venting and air intake components to ensure they are in good condition, gas tight and corrosion-free.

## 12.7 Maintenance Checklist

<b>⚠ WARNING</b>		
		
<b>Explosion Hazard</b>		
<p><b>Installation, service and annual inspection must be done by a contractor qualified in the installation and service of gas-fired heating equipment or your gas supplier.</b></p> <p><b>Turn off gas and electrical supplies before performing service or maintenance.</b></p> <p><b>Failure to follow these instructions can result in death, injury or property damage.</b></p>		

**Installation Code and Annual Inspections:** All installations and service of ROBERTS GORDON® equipment must be performed by a contractor qualified in the installation and service equipment sold and supplied by Roberts-Gordon and conform to all requirements set forth in the ROBERTS GORDON® manuals and all applicable governmental authorities pertaining to the installation, service and operation of the equipment.

To help facilitate optimum performance and safety, Roberts-Gordon recommends that a qualified contractor annually inspect your ROBERTS GORDON® equipment and perform service where necessary, using only replacement parts sold and supplied by Roberts-Gordon.

<b>The Vicinity of the Heater</b>	<p>Do not store or use flammable objects, liquids or vapors near the heater. Immediately remove these items if they are present.</p> <p><i>See Page 3, Section 3.</i></p>
<b>Vehicles and Other Objects</b>	<p>Maintain the clearances to combustibles.</p> <p>Do not hang anything from, or place anything on, the heater.</p> <p>Make sure nothing is lodged in between the heat exchanger tubes.</p> <p>Immediately remove objects in violation of the clearances to combustibles.</p> <p><i>See Page 3, Section 3.</i></p>
<b>Vent Pipe/Terminals</b>	<p>Venting must be intact. Using a flashlight, look for obstructions, cracks on the pipe, gaps in the sealed areas or corrosion.</p> <p>The area must be free of dirt and dust.</p> <p>Remove any carbon deposits or scale using a wire brush.</p> <p>If the vent terminal has a screen built in, remove any dirt, dust or deposits from the screen.</p> <p><i>See Page 17, Section 7.</i></p>
<b>Combustion Air Intake Pipe</b>	<p>Intake pipe and inlet must be intact. Look for obstructions, cracks on the pipe, gaps in the sealed areas or corrosion.</p> <p>The area must be free of dirt and dust.</p> <p>Clean and reinstall as required.</p>
<b>Heat Exchanger</b>	<p>Make sure there are no cracks.</p> <p>Make sure there is no sagging, bending or distortion.</p> <p>Clean or replace as required.</p> <p><i>See Page 18, Section 8.</i></p>

<b>Gas Line and Shut-off Valves</b>	<p>Check for gas leaks.</p> <p>See Page 18, Section 8.</p>
<b>Burner Observation Window</b>	<p>Make sure it is clean and free of cracks or holes.</p> <p>Clean and replace as required.</p>
<b>Flue Blower Scroll, Wheel and Motor</b>	<p>Compressed air or a vacuum cleaner may be used to clean dust and dirt.</p>
<b>Inshot Burners and Orifices</b>	<p>Clear obstructions (even spider webs will cause problems).</p> <p>Carefully remove any dust and debris from the burner.</p>
<b>Direct-Spark Igniter</b>	<p>Replace if there are cracked ceramics, excessive carbon residue, or erosion of the electrode.</p> <p>The electrode gap should be 1/8" (3.2 mm).</p>
<b>Thermostat</b>	<p>There should be no exposed wire or damage to the device or wiring.</p> <p>See Page 19, Section 9.1.</p>
<b>Suspension Points</b>	<p>Make sure the heater is hanging securely.</p> <p>Look for signs of wear on the suspension materials or ceiling.</p> <p>See Page 8, Figure 3.</p>
<b>Silicone Tubing</b>	<p>Ensure tight, secure fit on all pressure fittings at pressure switch, burner partition, and blower outlet.</p>
<b>Gas Valve</b>	<p>Verify that cap covering pressure regulator adjustment screw is secure and has not been tampered with.</p> <p>Verify all wiring connections.</p>
<b>Condensate Drain (when installed)</b>	<p>Flush drain and clear any obstructions.</p>
<b>Ductwork</b>	<p>Consult an indoor air quality professional for proper cleaning procedures.</p>
<b>Air Circulation Blower</b>	<p>For a complete inspection, refer to the manufacturers installation, operation and service manual.</p>
<b>Wall Tag</b>	<p>If wall tag is present, make sure it is legible and accurate. Please contact Roberts-Gordon LLC or your ROBERTS GORDON® independent distributor if you need a wall tag. See Page 2, Section 2.1.</p>

## SECTION 13: TROUBLESHOOTING

## 13.1 General

**⚠ WARNING**





**Explosion Hazard**

**Installation, service and annual inspection must be done by a contractor qualified in the installation and service of gas-fired heating equipment or your gas supplier.**

**Turn off gas and electrical supplies before performing service or maintenance.**

**Failure to follow these instructions can result in death, injury or property damage.**

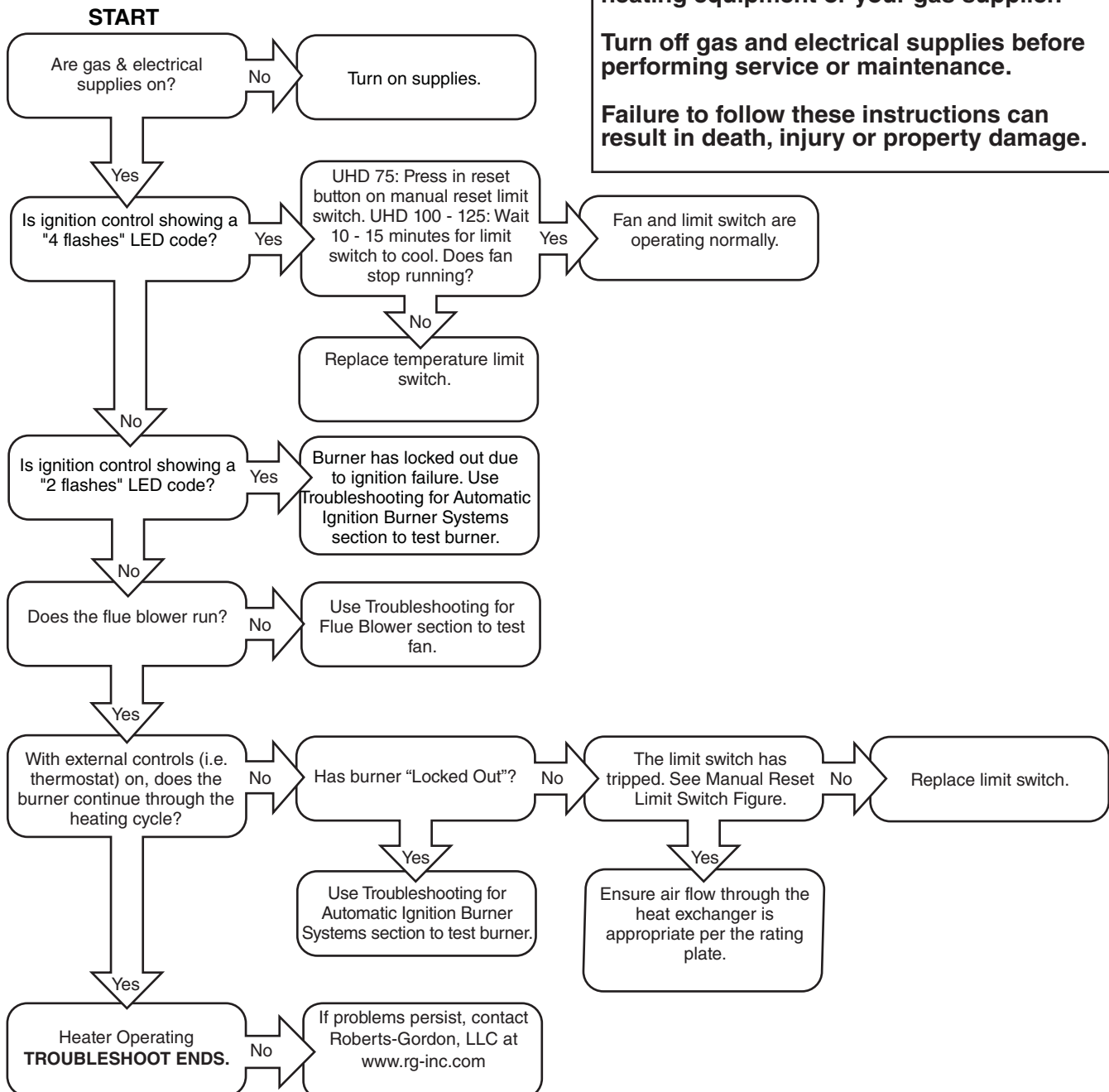

### 13.2 Troubleshooting For Automatic Ignition Burner Systems

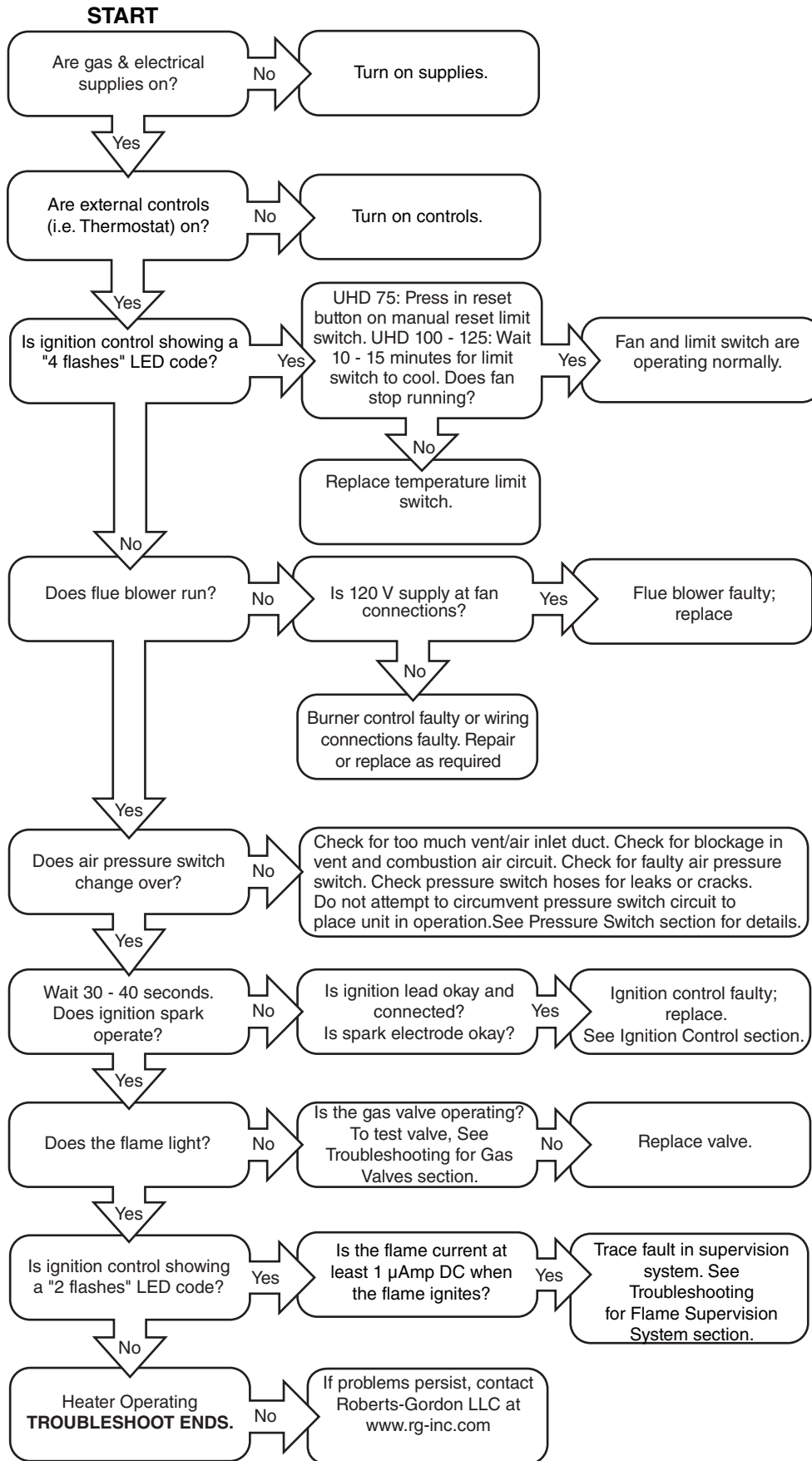

For optimum heater performance, use only replacement parts sold and supplied by Roberts-Gordon.  
**Conduct start-up procedure as shown on Page 23, Section 10.**

### 13.3 Troubleshooting for Flame Supervision System

To measure flame current, connect a 0 - 50  $\mu\text{A}$  DC meter in series with the flame probe. If the meter reads negative values, then reverse the test leads.

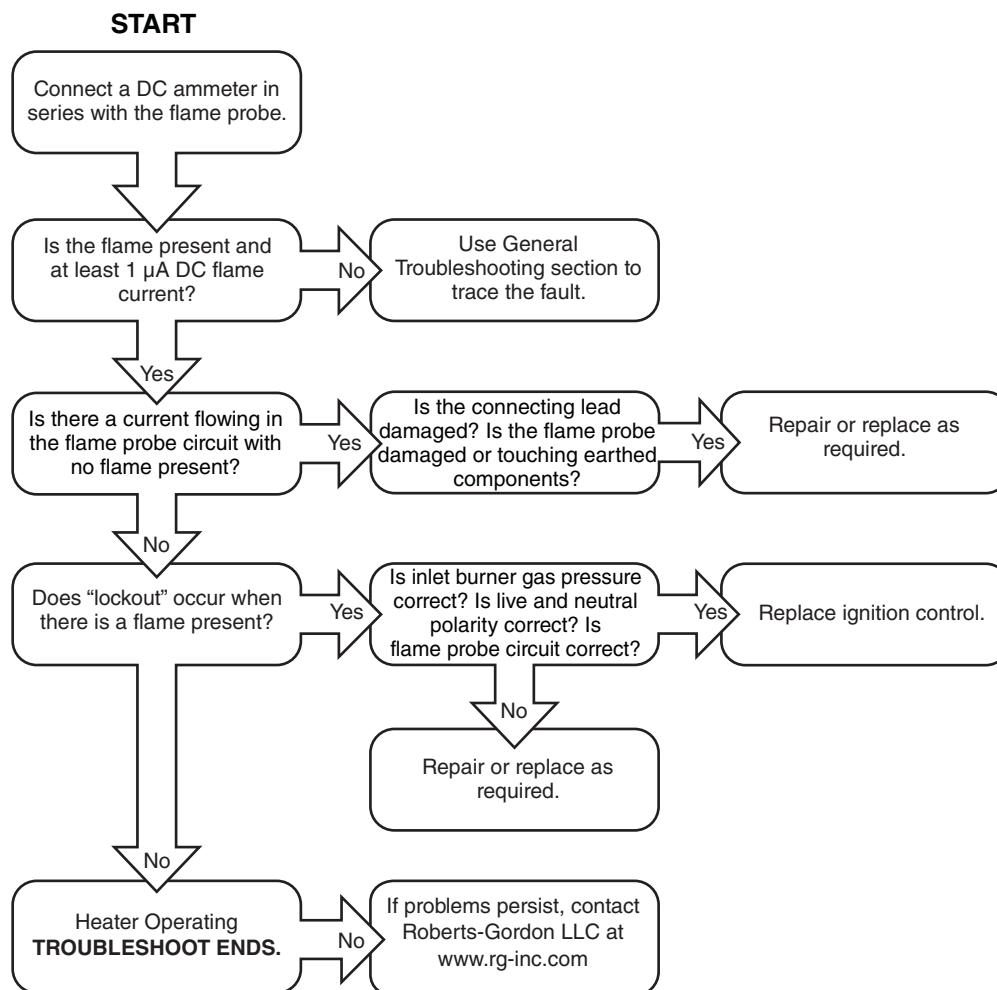

**NOTE:** Minimum flame probe current 1  $\mu\text{A}$  DC. Typical flame probe current 3-5  $\mu\text{A}$  DC.

### 13.4 Troubleshooting for Gas Valves

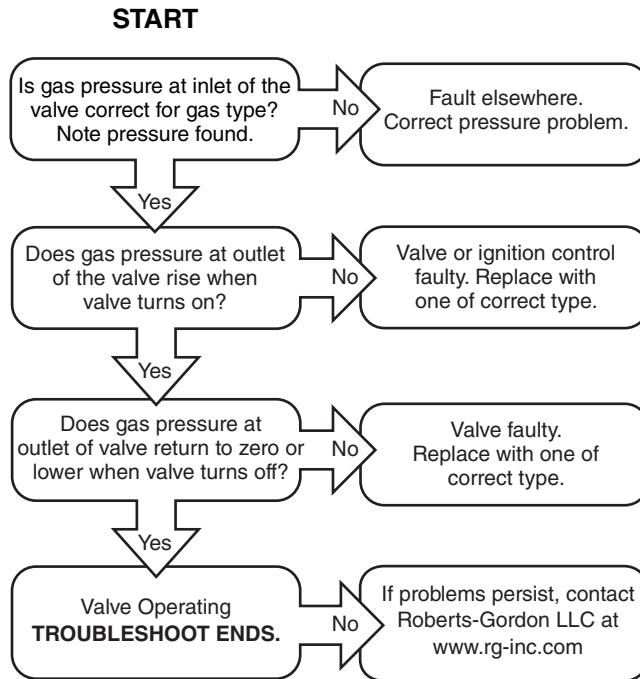

### 13.5 Troubleshooting for Flue Blower

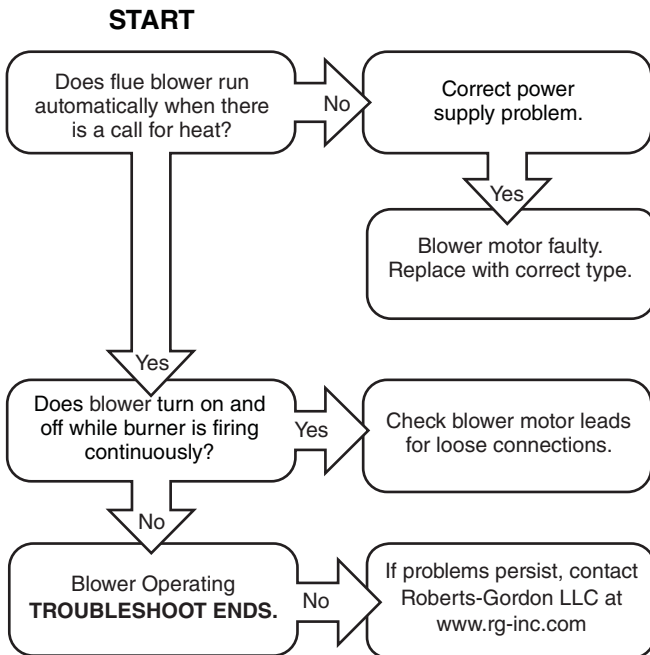

For optimum heater performance, use only replacement parts sold and supplied by Roberts-Gordon. **Conduct start-up procedure as shown on Page 23, Section 10.**



## SECTION 14: REPLACEMENT PARTS

**⚠ WARNING****Explosion Hazard**

**Installation, service and annual inspection must be done by a contractor qualified in the installation and service of gas-fired heating equipment or your gas supplier.**

**Turn off gas and electrical supplies before performing service or maintenance.**

**Failure to follow these instructions can result in death, injury or property damage.**

**Burner Components**

All serviceable burner parts are accessed by the door on the side of the heater. Remove the sheetmetal screws.

**14.1 Gas Valve**

Remove the gas supply pipe at the heater inlet.

Follow steps in *Section 14.2* and *Section 14.2.1* to remove gas valve/manifold.

Replace in reverse order. Verify that the gas flow direction of the valve is correct. Use a minimum amount of gas seal on the thread joint. Check that all the joints are leak free. Reset gas valve. See *Page 25, Section 10.2.2*.

**IT IS IMPORTANT THAT ONLY THE CORRECT GAS VALVE IS USED WHEN REPLACING THESE CONTROLS.**

See warnings and notes on *Page 28, Section 12* before removing or replacing parts.

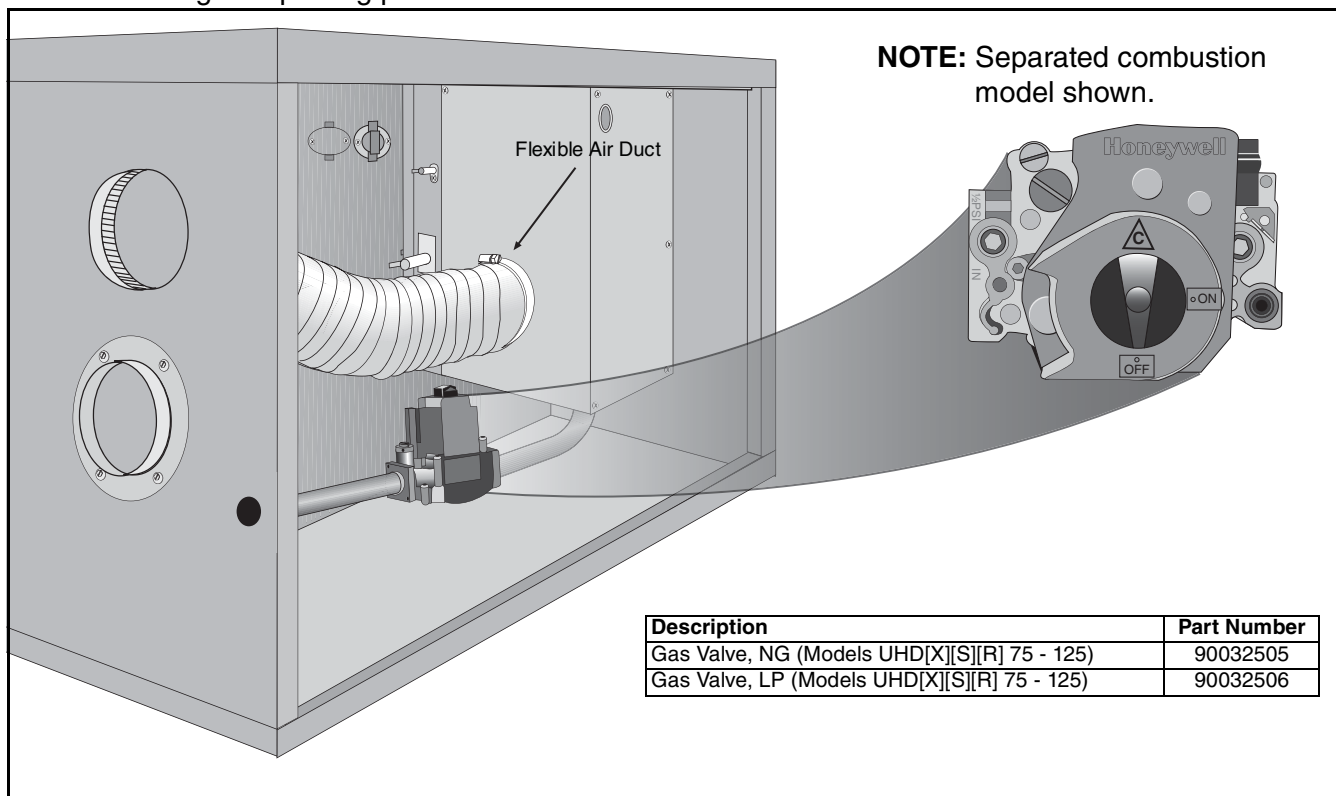

Description	Part Number
Gas Valve, NG (Models UHD[X][S][R] 75 - 125)	90032505
Gas Valve, LP (Models UHD[X][S][R] 75 - 125)	90032506

## 14.2 Burner Compartment

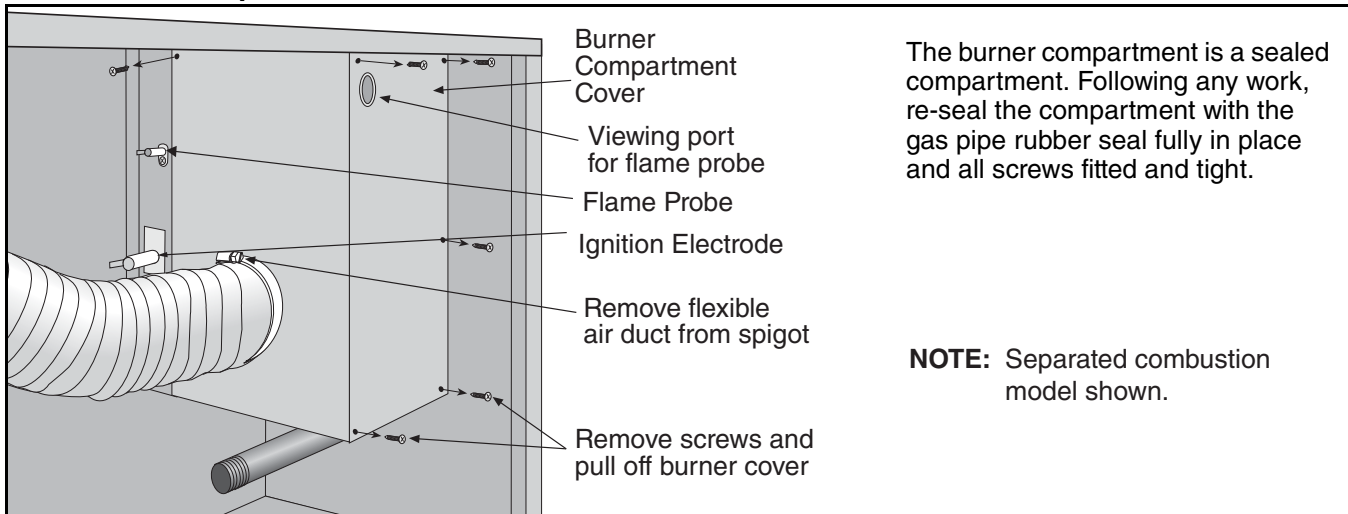

### 14.2.1 Burner Injectors

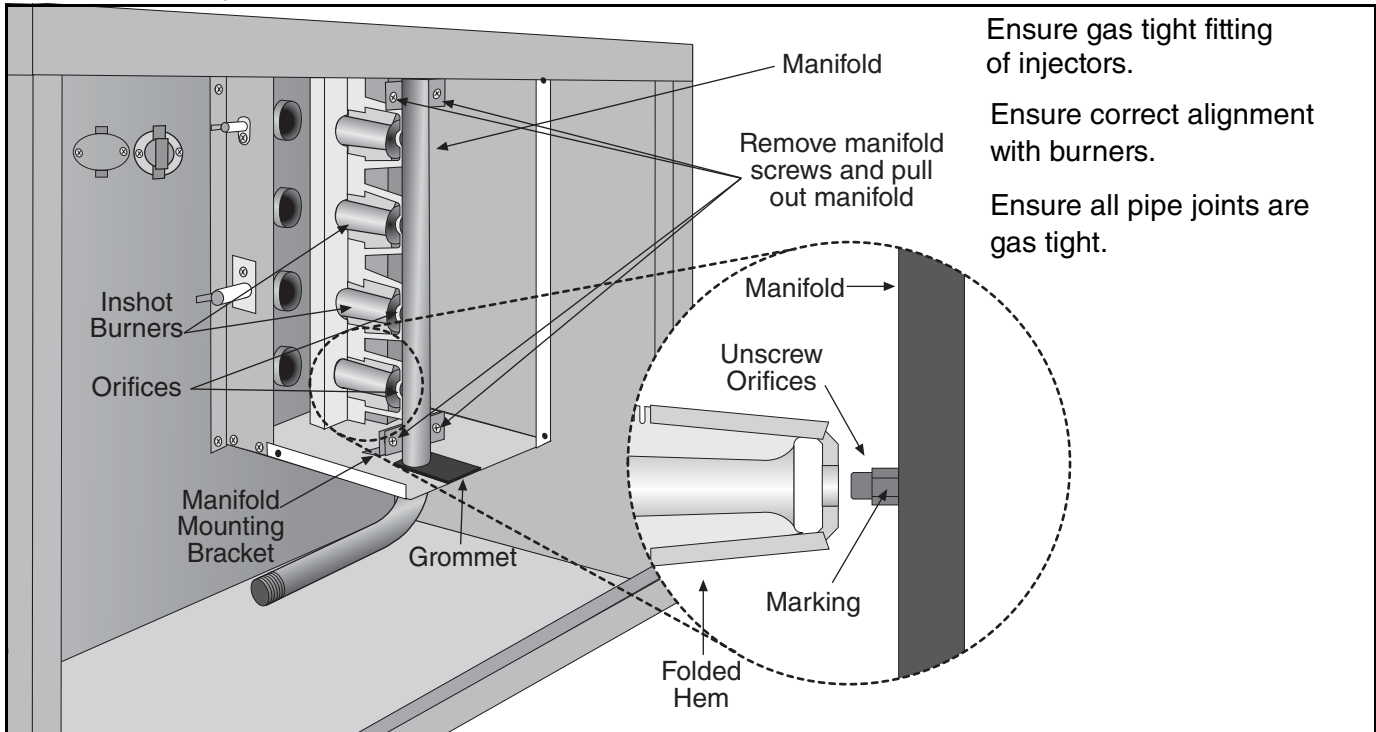

MODEL	UHD[X][S][R] 75	UHD[X][S][R] 100	UHD[X][S][R] 125
Orifice Quantity	5	6	7
<b>Natural Gas (G20)</b>			
Orifice Marking	49	46	46
P/N	91930049	91930046	91930046
<b>Propane (G31)</b>			
Orifice Marking	1.15 mm	1.25 mm	1.25 mm
P/N	91930115	91930125	91930125

14.3 Ignition Electrode and Flame Probe

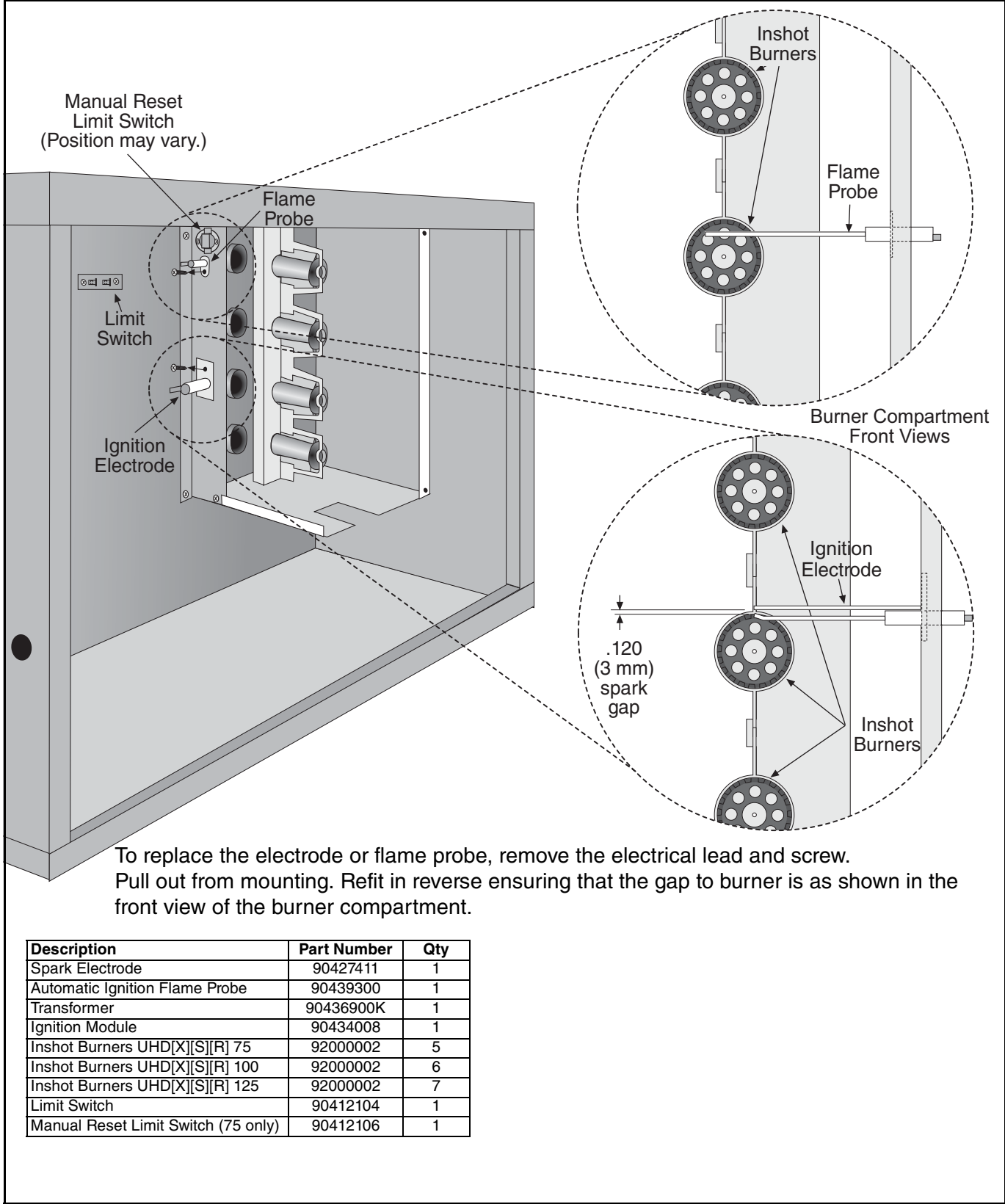

14.4 Heat Exchanger

The heat exchanger consists of a six-pass design with 1.5" outer diameter [aluminized steel] [409 stainless steel] tube. The tube plates are made of [aluminized steel] [409 stainless steel]. The tube supports are made of [galvannealed steel] [409 stainless steel].

### 14.5 Flue Blower Vertical Installation

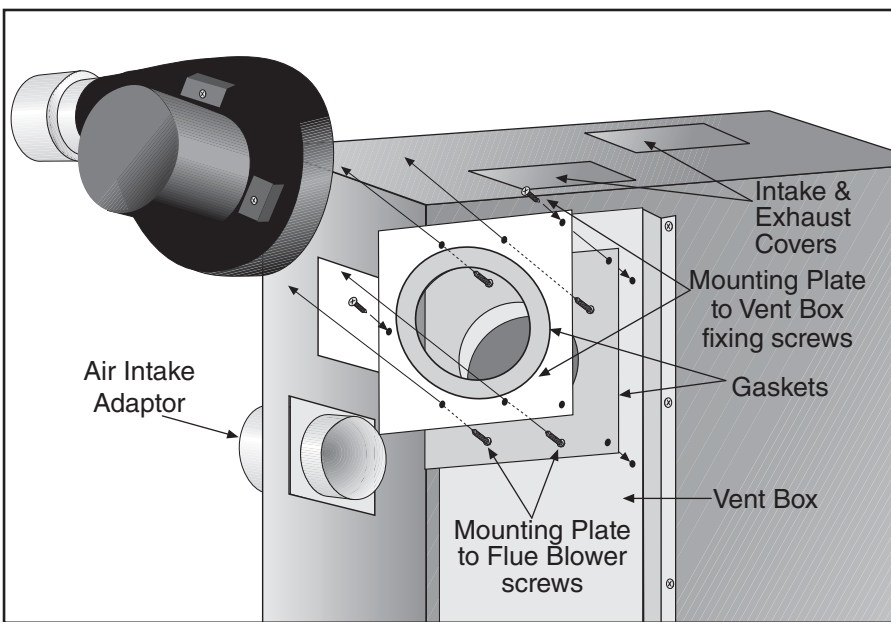

To remove the blower, remove screws securing the fan and mounting plate to the vent box.

To remove the blower from the mounting plate, remove screws.

Refit in reverse order.

To change the vent and air intake orientation from back to top, remove the blower and mounting plate as above.

Remove intake (if applicable) and exhaust covers from top of the heater.

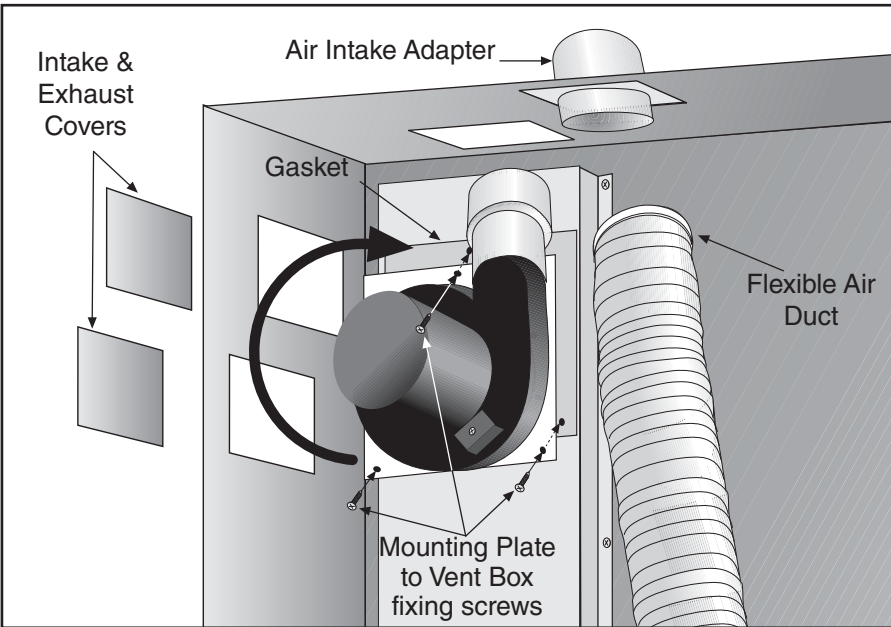

Rotate the blower, mounting plate and gasket clockwise until the flue adapter lines up with the top hole. Secure screws.

If applicable, remove the flexible air duct from the air intake adapter on the back.

If applicable, remove the air intake adapter from the back of the heater and install in the appropriate hole on top. Reconnect the flexible air duct.

Install intake and exhaust covers over the back holes.

**NOTE:** Separated combustion model shown.

MODEL	UHD[X][S][R] 75	UHD[X][S][R] 100	UHD[X][S][R] 125
Flue Blower P/N	90710404	90710405	90710405

**IT IS IMPORTANT THAT ONLY THE CORRECT FLUE BLOWER SPECIFIED FOR EACH MODEL TYPE IS USED WHEN REPLACING THESE ITEMS.**

Carry out a start-up after working on or changing a flue blower. See Page 26, Section 11.

## 14.6 Pressure Switch

WARNING



**Carbon Monoxide Hazard**

**Use correct pressure switch specified for each model according to manual.**

**Use of incorrect pressure switch or disabling pressure switch circuit could cause unsafe condition.**

**Failure to follow these instructions can result in death or serious injury.**

Pull off 3 way connector. Spring open plastic clips of mounting cradle. Replace with correct type of pressure switch for model. The pressure switches are color coded for each pressure setting.

Carry out a start-up after working on or changing a pressure switch. *See Page 23, Section 10.*

MODEL	UHD[X][S][R] 75	UHD[X][S][R] 100	UHD[X][S][R] 125
Pressure Switch Kit P/N	90439810	90439810	90439803
Color Code	black	black	gray
Set Point in wc	.35	.35	.41
Pressure Switch Snap Ring P/N	90439850	90439850	90439850

## 14.7 Ignition Control

The control mounts to the heat exchanger plate. Pull out ignition cable and wiring from board, noting their positions. Release the four mounting standoffs. Refit in reverse. Ensure correct location of ignition cable and all other wiring.

## 14.8 Limit Switches

### 14.8.1 Removal and Replacement

1. Remove the electrical connections to the switch.
2. Unscrew the two screws securing the switch.
3. Fit a new switch with two screws.
4. Reconnect the electrical connections and test operation.

**SECTION 15: SPECIFICATIONS**

**15.1 Dimension Data**

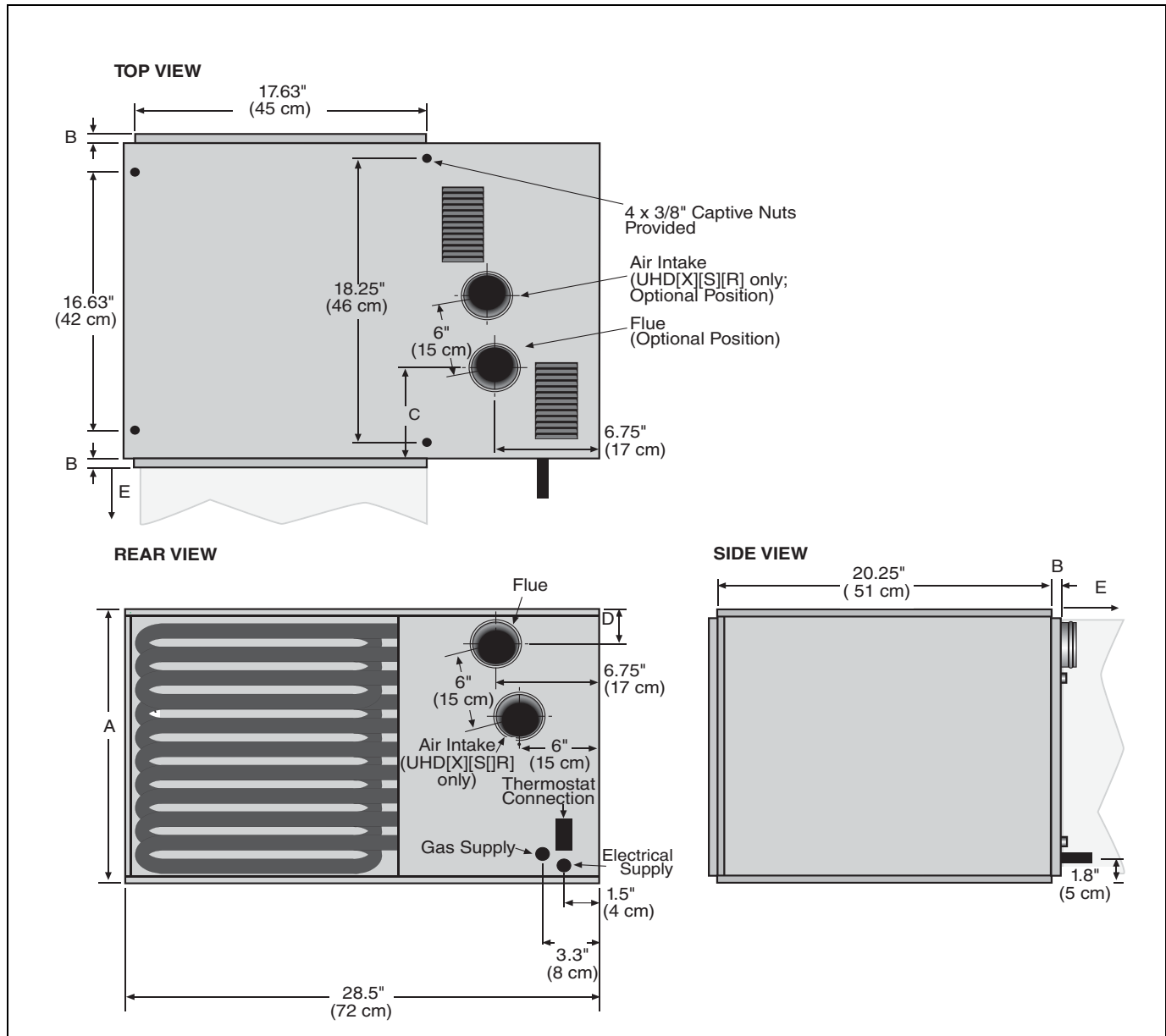

		Model	UHD [X][S][R] 75	UHD [X][S][R] 100	UHD [X][S][R] 125
<b>A</b>	Height	in (cm)	17.79 (45.09)	23 (58.42)	23 (58.42)
<b>B</b>	Duct Connector Flange	in (cm)	1.25 (3)	1.25 (3)	1.25 (3)
<b>C</b>	Center of Flue [Top Option]	in (cm)	5.2 (13.21)	6.9 (17.53)	6.9 (17.53)
<b>D</b>	Center of Flue	in (cm)	2.5 (6.35)	2.5 (6.35)	2.5 (6.35)
<b>E</b>	Minimum Inlet Duct Length	in (cm)	32 (81.28)	37 (93.98)	37 (93.98)
	Recommended Mounting Height to Heater Base	ft (m)	12 (3.66)	20 (6.10)	20 (6.10)
	Weight	lb	81	92	97

**15.2 General Technical Data Table**

	Model	UHD[X][S][R] 75	UHD[X][S][R] 100	UHD[X][S][R] 125
Full Load Amps @ 115 V	A	1	2	2
Minimum Air Volume	CFM	850	950	1020
Temperature Rise @ Minimum Air Volume	°F (°C)	68 (20)	78 (26)	92 (33)
Heat Exchanger Pressure Drop @ Minimum Air Volume	in wc	0.06	0.05	0.06
Maximum Air Volume	CFM	2650	3660	4750
Temperature Rise @ Maximum Air Volume	°F (°C)	22 (-6)	22 (-6)	20 (-7)
Heat Exchanger Pressure Drop @ Maximum Air Volume	in wc	0.36	0.55	0.98
Flue Size/Air Intake**	in (cm)	4 (10)-All models		

*\*Do not exceed the maximum length of flue stated or heater may not operate properly.*

**15.3 Technical Data Table**

	Model	UHD[X][S][R] 75	UHD[X][S][R] 100	UHD[X][S][R] 125
Total Input	(Btu/h) x (1000)	75	100	125
Total Output	(Btu/h) x (1000)	61.5	82	102.5
Efficiency	%	82-All models		
<b>Natural Gas (G20) Data - Inlet Pressure 5.0 in wc Min., 14 in wc Max.</b>				
Burner Pressure	in. wc	3.5	2.6	3.3
<b>LPG / Propane (G31) Data - Inlet Pressure 12.0 in wc Min., 14 in wc Max.</b>				
Burner Pressure	in. wc	10.0	9.1	10.0





**SECTION 16: ROBERTS GORDON® COMBAT® UHD-SERIES WARRANTY****ROBERTS GORDON® WILL PAY FOR:**

Within 24 months from date of purchase by buyer or 27 months from the date of shipment by Roberts-Gordon (whichever comes first), replacement parts will be provided free of charge for any part of the product which fails due to a manufacturing or material defect.

Roberts-Gordon will require the part in question to be returned to the factory. Roberts-Gordon will, at its sole discretion, repair or replace after determining the nature of the defect and disposition of part in question.

ROBERTS GORDON® Replacement Parts are warranted for a period of 18 months from date of shipment from Roberts-Gordon or the remaining ROBERTS GORDON® COMBAT® UHD-Series warranty.

**ROBERTS GORDON® WILL NOT PAY FOR:**

Service trips, service calls and labor charges.

Shipment of replacement parts.

Claims where the total price of the goods have not been paid.

Damage due to:

- Improper installation, operation or maintenance.
- Misuse, abuse, neglect, or modification of the ROBERTS GORDON® COMBAT® UHD-Series in any way.
- Use of the ROBERTS GORDON® COMBAT® UHD-Series for other than its intended purpose.
- Incorrect gas or electrical supply, accident, fire, floods, acts of God, war, terrorism, or other casualty.
- Improper service, use of replacement parts or accessories not specified by Roberts-Gordon.
- Failure to install or maintain the ROBERTS GORDON® COMBAT® UHD-Series as directed in the Installation, Operation and Service manual.
- Relocation of the ROBERTS GORDON® COMBAT® UHD-Series after initial installation
- The use of the ROBERTS GORDON® COMBAT® UHD-Series in a corrosive atmosphere containing contaminants.
- The use of the ROBERTS GORDON® COMBAT® UHD-Series in the vicinity of a combustible or explosive material.
- Any defect in the ROBERTS GORDON® COMBAT® UHD-Series arising from a drawing, design, or specification supplied by or on behalf of the consumer.
- Damage incurred during shipment. Claim must be filed with carrier.

**WARRANTY IS VOID IF:**

The ROBERTS GORDON® COMBAT® UHD-Series is not installed by a contractor qualified in the installation and service of gas-fired heating equipment.

You cannot prove original purchase date and required annual maintenance history.

The data plate and/or serial number are removed, defaced, modified or altered in any way.

The ownership of the ROBERTS GORDON® COMBAT® UHD-Series is moved or transferred. This warranty is nontransferable.

Roberts-Gordon is not permitted to inspect the damaged controller and/or component parts.

**READ YOUR INSTALLATION, OPERATION AND SERVICE MANUAL**

If you have questions about your controller, contact your installing professional. Should you need Replacement Parts or have additional questions, call or write:

**Roberts-Gordon**

1250 William Street

P.O. Box 44

Buffalo, New York 14240-0044

716.852.4400

On the web at: [www.rg-inc.com](http://www.rg-inc.com)

**Roberts-Gordon' liability, and your exclusive remedy, under this warranty or any implied warranty (including the implied warranties of merchantability and fitness for a particular purpose) is limited to providing replacement parts during the term of this warranty.** Some jurisdictions do not allow limitations on how long an implied warranty lasts, so this limitation may not apply to you. There are no rights, warranties or conditions, expressed or implied, statutory or otherwise, other than those contained in this warranty.

**Roberts-Gordon shall in no event be responsible for incidental or consequential damages or incur liability for damages in excess of the amount paid by you for the ROBERTS GORDON® COMBAT® UHD-Series.**

Some jurisdictions do not allow the exclusion or limitation of incidental or consequential damages, so this limitation or exclusion may not apply to you. This warranty gives you specific legal rights, and you may also have other rights which vary from jurisdiction to jurisdiction.

Roberts-Gordon shall not be responsible for failure to perform under the terms of this warranty if caused by circumstances out of its control, including but not limited to war, fire, flood, strike, government or court orders, acts of God, terrorism, unavailability of supplies, parts or power. No person is authorized to assume for Roberts-Gordon any other warranty, obligation or liability.

**LIMITATIONS ON AUTHORITY OF REPRESENTATIVES:**

No representative of Roberts-Gordon, other than an Executive Officer, has authority to change or extend these provisions. Changes or extensions shall be binding only if confirmed in writing by Roberts-Gordon's duly authorized Executive Officer.





# OWNER WARRANTY REGISTRATION CARD

Mail or Fax to:  
Roberts Gordon LLC • 1250 William Street, P.O. Box 44 • Buffalo, NY 14240-0044 • Phone: 716-852-4400 • Fax: 716-852-0854  
Toll Free: 800-828-7450 • www.rg-inc.com

**About the Owner:**

Name: \_\_\_\_\_  
Address: \_\_\_\_\_ City: \_\_\_\_\_ State: \_\_\_\_\_ Zip Code: \_\_\_\_\_  
Phone: \_\_\_\_\_ Fax: \_\_\_\_\_ E-mail: \_\_\_\_\_

**About the Installer:**

Name: \_\_\_\_\_  
Address: \_\_\_\_\_ City: \_\_\_\_\_ State: \_\_\_\_\_ Zip Code: \_\_\_\_\_  
Phone: \_\_\_\_\_ Fax: \_\_\_\_\_ E-mail: \_\_\_\_\_

**Purchased From (if different than installer):**

Name: \_\_\_\_\_  
Address: \_\_\_\_\_ City: \_\_\_\_\_ State: \_\_\_\_\_ Zip Code: \_\_\_\_\_  
Phone: \_\_\_\_\_ Fax: \_\_\_\_\_ E-mail: \_\_\_\_\_

**About your Heater:**

Model#: \_\_\_\_\_ Serial #: \_\_\_\_\_ Fuel: \_\_\_\_\_ Installation Date: \_\_\_\_\_

**Type of Installation (check one):**

- Automotive       Manufacturing       Warehouse       Recreational       Aircraft
- Public Building       Office       Retail       Agricultural       Other \_\_\_\_\_

**Installation Code and Annual Inspections:** All installations and service of ROBERTS GORDON® equipment must be performed by a contractor qualified in the installation and service of equipment sold and supplied by Roberts-Gordon and conform to all requirements set forth in the ROBERTS GORDON® manuals and all applicable governmental authorities pertaining to the installation, service and operation of the equipment.

To help facilitate optimum performance and safety, Roberts-Gordon recommends that a qualified contractor annually inspect your ROBERTS GORDON® equipment and perform service where necessary, using only replacement parts sold and supplied by Roberts-Gordon.

**These products are not approved for residential use.**

© 2008 Roberts-Gordon LLC - All rights reserved. No part of this work covered by the copyrights herein may be reproduced or copied in any form or by any means – graphic, electronic, or mechanical, including photocopying, recording, taping, or information storage and retrieval systems – without written permission of Roberts Gordon LLC.

Printed in the U.S.A.





Attach this information to the wall near the ROBERTS GORDON® heater



Read the Installation, Operation and Service Manual thoroughly before installation, operation or service.

**OPERATING INSTRUCTIONS**

1. STOP! Read all safety instructions on this information sheet.
2. Open the manual gas valve in the heater supply line.
3. Turn on electric power to the heater.
4. Set the thermostat to desired setting (above ambient temperature).  
The automatic starting sequence begins.

**TO TURN OFF THE HEATER**

1. Turn the thermostat/time switch to 'OFF' or lowest setting. The burner will turn 'OFF' immediately, but fans will continue to cool heat exchanger until the fan thermostat switches off.

**IF THE HEATER WILL NOT OPERATE, TO ENSURE YOUR SAFETY, FOLLOW THESE INSTRUCTIONS TO SHUT DOWN YOUR HEATER**

1. Set the thermostat to off or the lowest setting.
2. Turn off electric power to the heater.
3. Turn off the manual gas valve in the heater supply line.
4. Call your installer/contractor qualified in the installation and service of gas-fired heating equipment.

**⚠ WARNING**



**Fire Hazard**

Some objects can catch fire or explode when placed close to heater.

Keep all flammable objects, liquids and vapors the required clearances to combustibles away from heater.

Failure to follow these instructions can result in death, injury or property damage.

**Clearances to Combustibles**

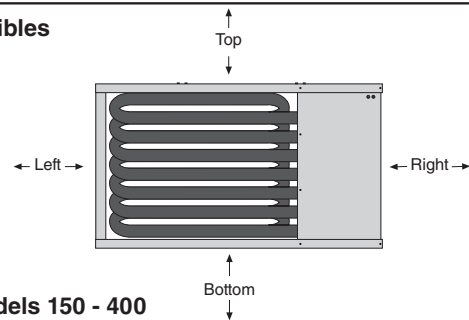
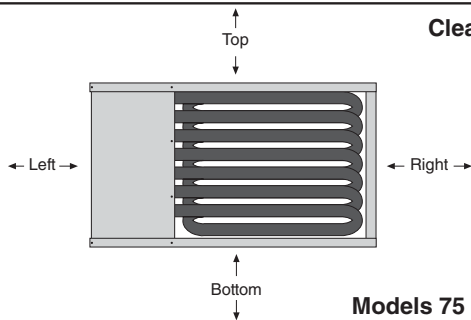

Models	75 - 125	150 - 400
Top	1"	6"
Bottom	1"	6"
Right	1"	31"
Left	18"	6"
Vent	2"	2"

\* Clearance needed for servicing.

Roberts-Gordon LLC  
1250 William Street  
P.O. Box 44  
Buffalo, NY 14240-0044 USA

Telephone: 716.852.4400  
Fax: 716.852.0854  
Toll Free: 800.828.7450

**Installation Code and Annual Inspections:**

All installation and service of ROBERTS GORDON® equipment must be performed by a contractor qualified in the installation and service of equipment sold and supplied by Roberts-Gordon and conform to all requirements set forth in the ROBERTS GORDON® manuals and all applicable governmental authorities pertaining to the installation, service and operation of the equipment. To help facilitate optimum performance and safety, Roberts-Gordon recommends that a qualified contractor conduct annual inspections of your ROBERTS GORDON® equipment and perform service where necessary, using only replacement parts sold and supplied by Roberts-Gordon.

For installations at elevations above 2000' (610 m), the appliance shall be derated 4% for each 1000' (305 m) of elevation above sea level.

**Further Information:** Applications, engineering and detailed guidance on systems design, installation and equipment performance is available through ROBERTS GORDON® representatives. Please contact us for any further information you may require, including the Installation, Operation and Service Manual.

**This product is not for residential use.**