



Cat. No. 43-698A
OWNER'S MANUAL

Please read before using this equipment.

ET-598

25-Channel 2-Line Cordless Telephone with Dual Keypads



RadioShack®

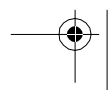

FEATURES

Your RadioShack ET-598 25-Channel 2-Line Cordless Telephone with Dual Keypads lets you place and receive calls on two separate telephone lines. It is designed to exacting standards that ensure reliability, long life, and outstanding performance.

Its features include:

Two-Line Telephone System — lets you easily handle two telephone lines at the same time. You can also use both lines at the same time to make 4-way conference calls.

Dual Keypads — a full set of keys on both the ET-598's handset and base let you use either keypad to make and answer calls or program the phone's features.

Speakerphone — lets you make or answer calls without using the handset.

25 Channels — lets you change to another channel during a call to reduce interference.

20-Number Memory Dialing — lets you store up to 20 numbers in memory (10 on the handset and 10 on the base) for easy dialing.

Super CCT Noise-Reduction Circuitry — gives you sound clarity comparable to corded telephones.

Security Access-Protection Code — prevents other cordless phone users from using your phone line while the handset is off the base.

COM-LOK® — ensures that other cordless phone users cannot use your phone line when the handset is on the base.

Redial — lets you quickly redial the last number dialed.

Paging/Two-Way Intercom System — sends a signal from the base to the handset so you can page someone or locate the handset if you have misplaced it. If someone answers, you can use the ET-598 like a two-way intercom.

Flash — sends an electronic switch-hook signal so you can use the phone with special phone services, such as Call Waiting.

Tone/Pulse Dialing — lets you use your phone with either type of service.

Quick Talk — lets you quickly make or answer a call by simply lifting the handset from the base.

Hearing-Aid Compatibility — lets you use your phone with hearing aids that have a T (telephone) switch.

© 1996 Tandy Corporation.
All Rights Reserved.

COM-LOK and RadiShack are registered trademarks used by Tandy Corporation.

This telephone has been tested and found to comply with all applicable UL and FCC standards.



We recommend you record your phone's serial number here. The number is on the bottom of the base.

Serial Number: _____

Important Note: Cordless phones such as your ET-598 require AC power to operate. When the AC power is off, you cannot dial out or receive incoming calls using this phone. To be safe, you should also have a phone that does not need AC power to operate (not a cordless phone) so you can still make and receive calls if there is an AC power failure.

Your telephone operates on standard radio frequencies as allocated by the FCC. Even though the access protection code prevents unauthorized use of your phone line, it is possible for other radio units operating on similar frequencies within a certain area to unintentionally intercept your conversations and/or cause interference. This lack of privacy can occur with any cordless phone.

Warning: To prevent fire or shock hazard, do not expose this product to rain or moisture.

	CAUTION RISK OF ELECTRIC SHOCK. DO NOT OPEN.	
CAUTION: TO REDUCE THE RISK OF ELECTRIC SHOCK, DO NOT REMOVE COVER OR BACK. NO USER-SERVICEABLE PARTS INSIDE. REFER SERVICING TO QUALIFIED PERSONNEL.		



This symbol is intended to alert you to the presence of uninsulated dangerous voltage within the product's enclosure that might be of sufficient magnitude to constitute a risk of electric shock. Do not open the product's case.



This symbol is intended to inform you that important operating and maintenance instructions are included in the literature accompanying this product.

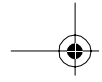

READ THIS BEFORE INSTALLATION

Each device that you connect to the phone line draws power from the phone line. We refer to this power draw as the device's *ringer equivalence number*, or REN. The REN for your ET-598 is located on the bottom of the base.

If you are using more than one phone or other device on the line, add up all the RENs. If the total is more than five, your phones might not ring. In rural areas, a total REN of three might impair ringer operation. If ringer operation is impaired, remove a device from the line.

FCC STATEMENT

This telephone complies with Part 68 of *FCC Rules*. Upon request, you must provide the FCC Registration Number and the REN to your phone company. These numbers are located on the bottom of the base.

Note: You must not connect your phone to any of the following:

- coin-operated systems
- party-line systems
- most electronic key phone systems

CONTENTS

Installation	6
Selecting a Location	6
Mounting/Connecting the Phone	6
Placing the Base on a Desk Top	7
Mounting the Base on a Wall Plate	8
Mounting the Base Directly on the Wall	10
Connecting and Charging the Battery Pack	12
Setting the Dialing Mode	14
Turning the Ringer On/Off	14
Operation	15
Handset Operation	15
Making a Call	15
Answering a Call	15
Changing the Channel	16
Speakerphone Operation	16
Making a Call	16
Answering a Call	16
Using Privacy	17
Adjusting the Speakerphone Volume	17
Putting a Call on Hold	17
Switching Between the Handset and Speakerphone	18
Using Both the Handset and Speakerphone	18
Making a Conference Call	19
Using Redial	20
Using Flash	20
Using Tone Services on a Pulse Line	20
Using the Paging/Intercom Features	21
Memory Dialing	22
Storing a Number in Memory	22
Entering a Pause	23
Dialing a Memory Number	23
Chain-Dialing Service Numbers	23
Testing Stored Emergency Numbers	23
Troubleshooting	24
Care and Maintenance	26
Replacing the Battery Pack	27
The FCC Wants You to Know	28
Lightning	28



INSTALLATION

SELECTING A LOCATION

You can place the phone on a desk top or table, or mount it on a wall. Select a location that is:

- near an AC outlet
- near a telephone line jack
- out of the way of normal activities
- away from electrical machinery, electrical appliances, metal walls or filing cabinets, wireless intercoms, alarms, and room monitors
- away from other cordless phones

The base's location affects the handset's range. If you have a choice of several locations, try each to see which provides the best performance.

MOUNTING/CONNECTING THE PHONE

To use both of the ET-598's lines, you must connect it to two separate telephone lines. Each of these lines must have its own phone number. If you do not have two telephone lines, contact your phone company to get a second line.

You can connect your telephone to a 2-line modular telephone jack using the supplied 2-line modular cord.

Or, you can connect it to two separate 1-line modular telephone jacks using the supplied 2-line modular cord and a 1-line modular cord (such as RadioShack Cat. No. 279-356, not supplied).

Notes:

- Two-line and single-line modular cords look alike but are wired differently. To use the ET-598's two lines, use only the supplied two-line modular cord to connect to a two-line modular jack.
- You can also use the ET-598 with a single 1-line modular jack.

If your phone wiring does not have a modular phone jack, you can:

- Update the wiring yourself, using jacks and adapters available at your local RadioShack store
- Have the phone company update the wiring for you

Note: The USOC number of the jack to be installed is RJ14C for a two-line baseboard jack or RJ14W for a two-line wall-plate jack.

Caution: The supplied RadioShack adapter was designed specifically for your ET-598. Use only the supplied adapter.

Placing the Base on a Desk Top

Follow these steps when you place the base on a desk, shelf, or table.

1. If you have a single 2-line modular jack, plug one end of the supplied modular cord into the **TEL LINE 1/2** jack.

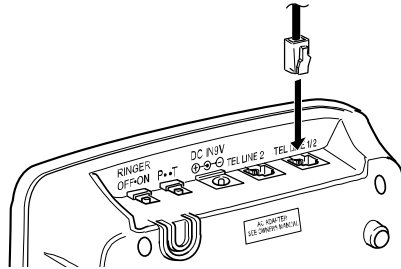

Note: When you make this connection, you should not connect another modular cord to the **TEL LINE 2** jack or phone operation will be erratic.

If you have two separate 1-line modular jacks, plug one end of the supplied modular cord into the **TEL LINE 1/2** jack and plug another modular cord (not supplied) into the **TEL LINE 2** jack.

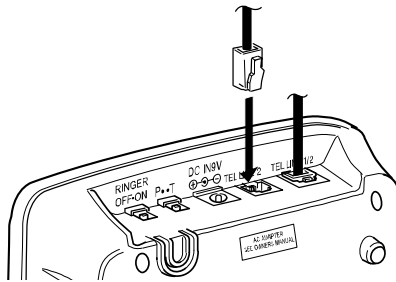

If you have only a single 1-line modular jack, plug one end of the supplied modular cord into the **TEL LINE 1/2** jack to use line 1, or into the **TEL LINE 2** jack to use line 2.

2. Plug the supplied AC adapter's barrel plug into the **DC IN 9V** jack.

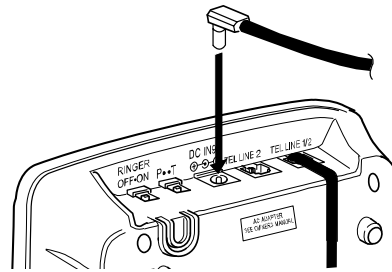

3. Route the adapter's cord through the strain relief slot.

Strain Relief Slot

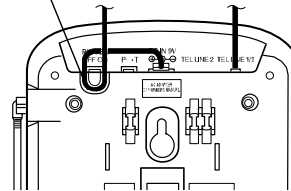

4. Plug the adapter into a standard AC outlet. The **POWER** indicator on the base lights.

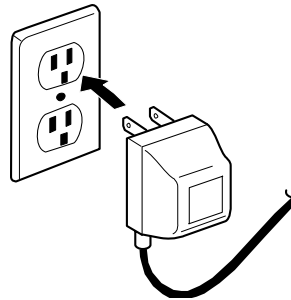

5. Plug the other end(s) of the modular cord(s) into the modular jack(s).

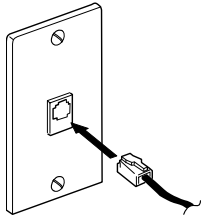

6. Raise the base's antenna to a vertical position and fully extend it.

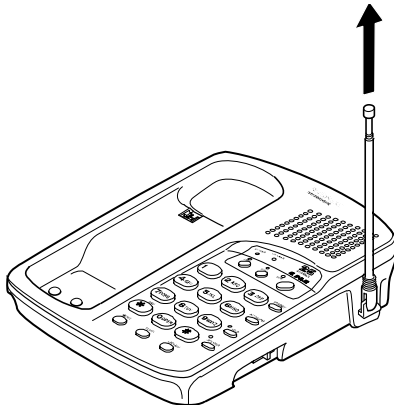

Mounting the Base on a Wall Plate

To make this connection, you need a 2-line short modular cord, such as Cat. No. 279-390 (not supplied).

1. If you have a single 2-line modular jack on the wall plate, plug one end of a 2-line short modular cord into the **TEL LINE 1/2** jack.

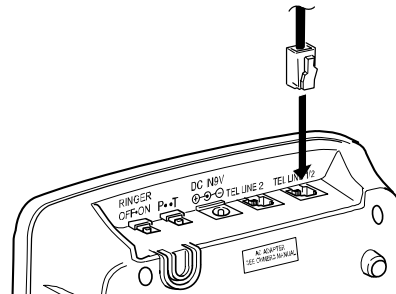

Note: When you make this connection, you should not connect another modular cord to the **TEL LINE 2** jack or phone operation will be erratic.

If you have a single 1-line modular jack on the wall plate and a modular wall jack close by, plug one end of a short modular cord into the **TEL LINE 1/2** jack to use line 1, then connect the supplied modular cord into the **TEL LINE 2** jack to use line 2.

If you have only a single 1-line modular jack on the wall plate, plug one end of a short modular cord into the **TEL LINE 1/2** jack to use line 1, or to the **TEL LINE 2** jack to use line 2.

2. Plug the supplied AC adapter's barrel plug into the **DC IN 9V** jack.

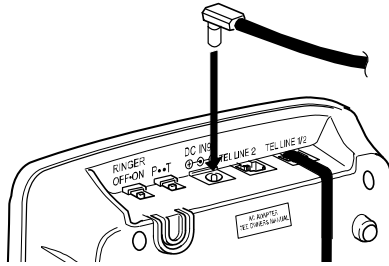

3. Route the adapter cord through both the upper and lower grooves and the modular cord(s) through only the upper groove on the bottom of the base.

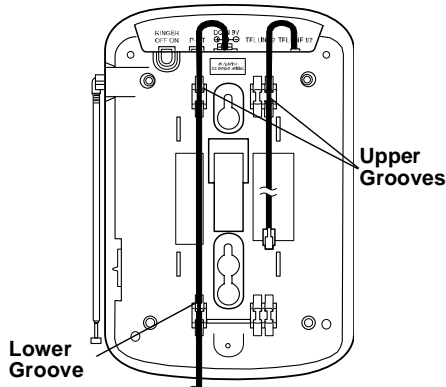

Note: If you are using two modular cords, route both through the appropriate grooves.

4. Plug the adapter into a standard AC outlet. The **POWER** indicator on the base lights.

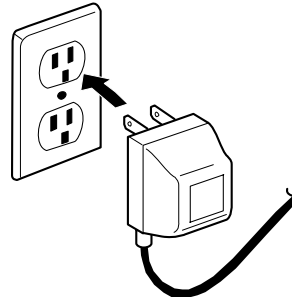

5. Plug the other end(s) of the modular cord(s) into the wall plate jack (and wall jack, if appropriate), then align the base's keyhole slots with the wall plate studs and slide the base downward to secure it.

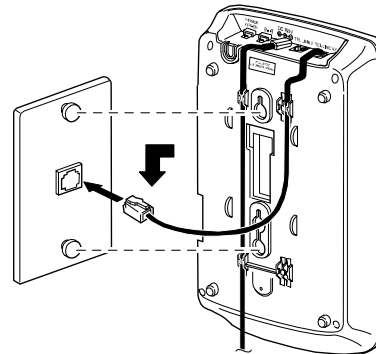

6. Press and lift out the handset holder, rotate it 180°, then snap it back into place so it holds the handset.

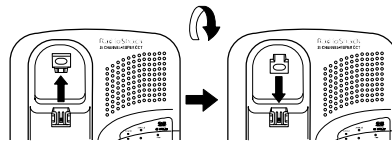

7. Raise the base's antenna to a vertical position and fully extend it.

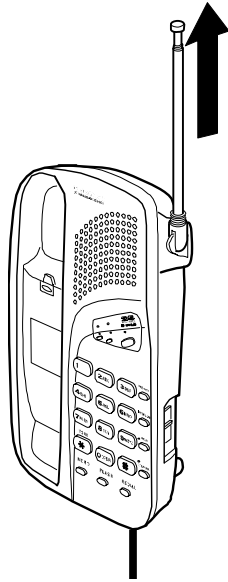

2. If you have a single 2-line modular jack, plug one end of the supplied modular cord into the **TEL LINE 1/2** jack.

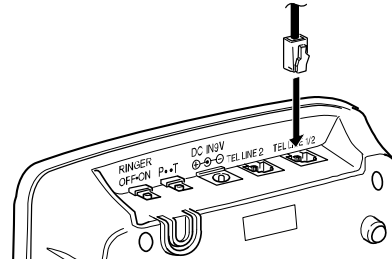

Note: When you make this connection, you should not connect another modular cord to the **TEL LINE 2** jack or phone operation will be erratic.

If you have two separate 1-line modular jacks, plug one end of the supplied modular cord into the **TEL LINE 1/2** jack and plug another modular cord (not supplied) into the **TEL LINE 2** jack.

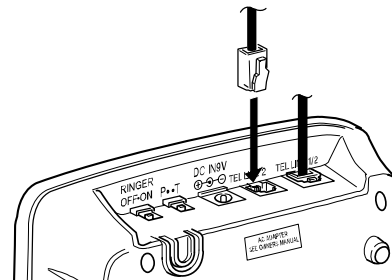

If you have only a single 1-line modular jack, plug one end of the supplied modular cord into the **TEL LINE 1/2** jack to use line 1, or into the **TEL LINE 2** jack to use line 2.

Mounting the Base Directly on the Wall

To mount the base directly on the wall, you need two wood screws (not supplied) with heads that fit into the keyhole slots on the bottom of the base.

1. Drill two holes $3^{15}/16$ inches apart. Then thread a screw into each hole, letting the heads extend about $5/16$ inch from the wall.

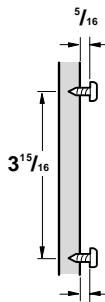

3. Plug the supplied AC adapter's barrel plug into the **DC IN 9V** jack.

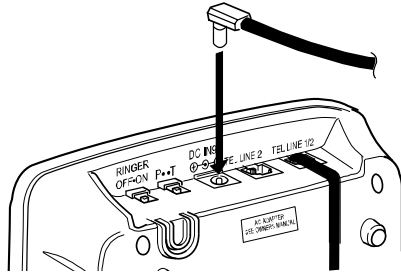

4. Route the adapter and modular cords through both the upper and lower grooves on the bottom of the base.

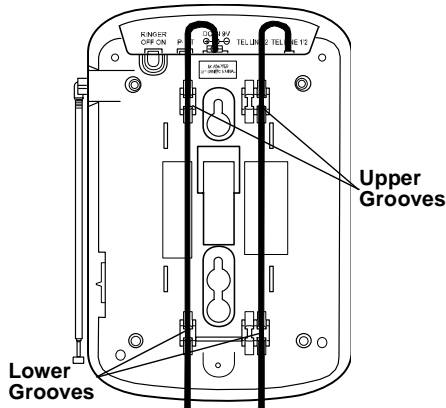

Note: If you are using two modular cords, route both through the appropriate grooves.

5. Plug the adapter into a standard AC outlet. The **POWER** indicator on the base lights.

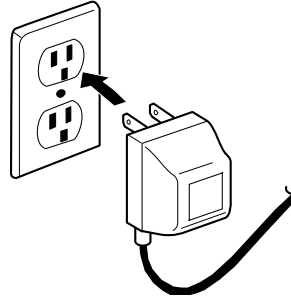

6. Plug the other end(s) of the cord(s) into a modular phone line jack(s).

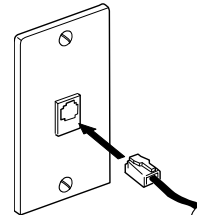

7. Align the keyhole slots with the mounting screws and slide the base downward to secure it.

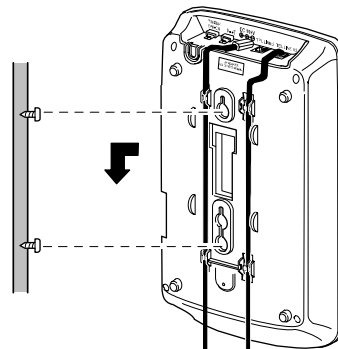

8. Press and lift out the handset holder, rotate it 180°, then snap it back into place so it holds the handset.

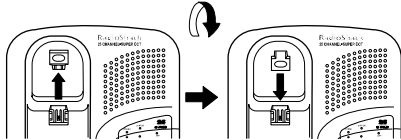

9. Raise the base's antenna to a vertical position and fully extend it.

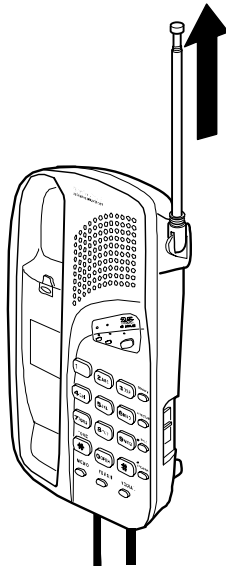

CONNECTING AND CHARGING THE BATTERY PACK

The ET-598 comes with a rechargeable nickel-cadmium battery pack installed in the handset. Before using your phone, you must connect the battery pack, then charge it for about 14 hours.

1. Remove the screw from the battery compartment cover on the bottom of the handset, then press down and slide off the handset's cover.

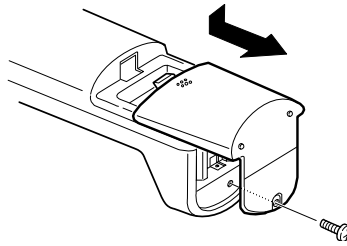

2. Plug the battery pack's plastic connector into the phone's socket. The connector fits only one way.

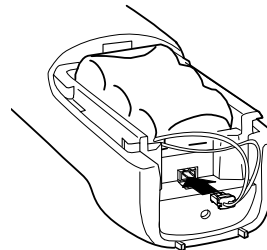

3. Replace the cover and tighten the screw.

4. To charge the battery pack, simply place the handset on the base. The CHARGE indicator on the base lights.

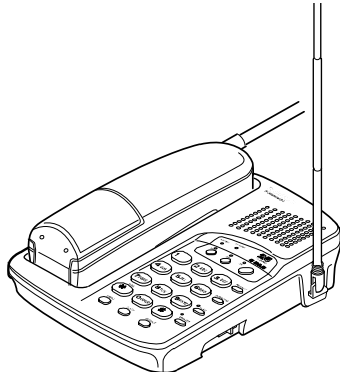

Recharge the battery pack when the BATT LOW indicator flashes.

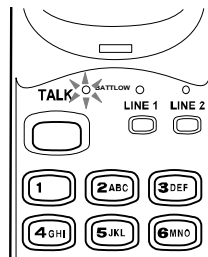

Notes:

- If the CHARGE indicator does not light when you place the handset on the base, be sure the battery pack and AC adapter are correctly and securely connected.
- When you first use the phone after charging or recharging the battery pack, the phone might not work and you might hear an error tone. If this happens, return the handset to the base for a few seconds.

- If the BATT LOW indicator does not flash and the phone does not work, recharge the battery pack. (The battery charge might be too low to flash the indicator.)
- If the battery pack gets weak during a call, the handset sounds a beep every 30 seconds, and the BATT LOW indicator flashes. If this happens, you must recharge the battery pack before you can make another call.
- About once a month, fully discharge the battery pack by keeping the handset off the base until the BATT LOW indicator flashes. Otherwise, the battery pack loses its ability to fully recharge.
- Using a pencil eraser, clean the charging contacts on the handset and the base about once a month to make sure they are not dirty or tarnished.

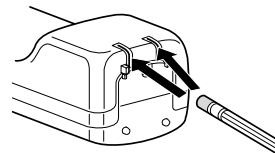
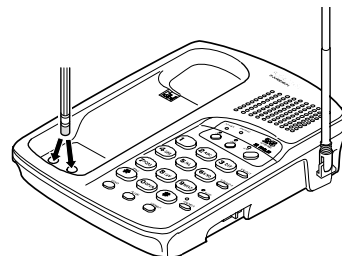

SETTING THE DIALING MODE

Set **P••T** on the back of the base for the type of service you have. If you are not sure which type you have, do this test.

1. Set **P••T** to **T** (tone).

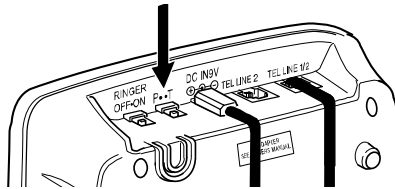

2. Press **SPEAKER** then press **LINE 1** and listen for the dial tone.
3. Press any number other than **0**.

Note: If your phone system requires that you dial an access code (9, for example) before you dial an outside number, do not press the access code either.

If the dial tone stops, that line has tone service.

If the dial tone continues, that line has pulse service.

4. Press **LINE 2**, listen for the dial tone, and repeat Step 3.

If you have tone service on both lines, leave **P••T** set to **T**.

If you have pulse service on either line, set **P••T** to **P** (pulse).

TURNING THE RINGER ON/OFF

You can turn the ringer on the base on or off. Set **RINGER** on the back of the base to the position you want.

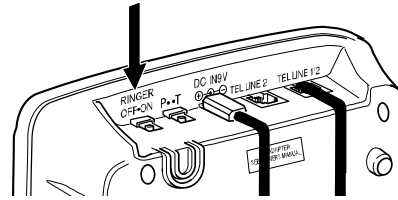

The switch setting affects the ringer on the base only. The handset's ringer is always turned on as long as the handset is off the base. When you place the handset *on* the base and set **RINGER** to **OFF**, the ET-598 does not ring when it receives a call. However, other phones connected to the same phone line still ring.

OPERATION

Note: You can use the keypad on either the handset or the base to operate the ET-598. To use the speakerphone, you must use the base's keypad; to use the handset, you must use the handset's keypad.

HANDSET OPERATION

Making a Call

To make a call using the handset, lift the handset from the base and listen for a dial tone. If the handset is away from the base, press **TALK** and listen for a dial tone. On the handset, the BATT LOW indicator and a LINE indicator (1 or 2, whichever line was dialed the last time) light. The indicator for the same line flashes on the base, indicating that line is in use at the handset. Use the handset keypad to dial the desired number.

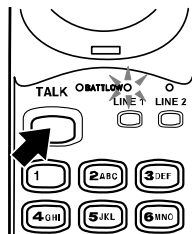

You can also press **LINE 1** or **LINE 2** to directly select the line you want to use. If either indicator is flashing, someone at the base is using that line on the speakerphone. Press the line button whose indicator is not lit.

Answering a Call

To help you tell which line is ringing, each line has a distinctive ring tone.

To answer a call, simply lift the handset. If the handset is away from the base, press **TALK** to answer the flashing line. The BATT LOW indicator and the LINE 1 or LINE 2 indicator on the handset light. The indicator for the line in use flashes on the base.

To disconnect a call, press **TALK** on the handset or place the handset on the base.

Notes:

- If you press **TALK** to hang up and the phone does not disconnect, hold the handset closer to the base, then press **TALK** again.
- When you receive an incoming call on one line while you are using the handset to talk on the other, the handset does not ring but you hear a tone through the earpiece. Place the current call on hold (see "Putting a Call on Hold" on Page 17), then press the line button for the incoming call.

If you press the other line's button without first pressing **HOLD**, the first call is disconnected.

Changing the Channel

If you notice interference, static, or noise during a call, press **CH** (channel) to find a clearer channel.

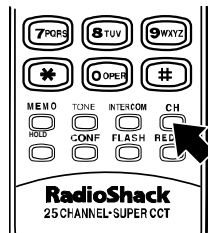

The ET-598 changes to a different channel each time you press **CH**.

Note: If the handset is too far away from the base, the channel might not change. Move closer to the base and try again.

SPEAKERPHONE OPERATION

Making a Call

To make a call using the speakerphone, simply press **SPEAKER**. The **SPEAKER** indicator and either the **LINE 1** or **LINE 2** indicator light on the base. The indicator for the same line flashes on the handset as a reminder that the line is in use. Use the base keypad to dial the desired number.

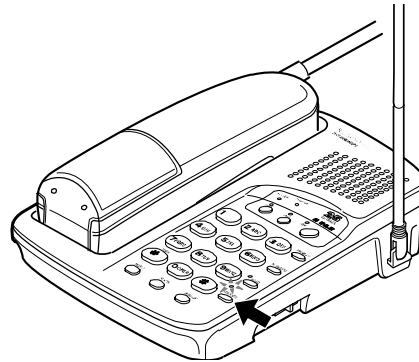

You can also press **LINE 1** or **LINE 2** to directly select the line you want to use. If either indicator is flashing, someone at the handset is using the line. Press the line button whose indicator is not lit.

Answering a Call

To answer a call using the speakerphone, simply press **SPEAKER** or either **LINE 1** or **LINE 2**, whichever is flashing. The **SPEAKER** indicator and the selected line indicator light. The indicator for the line in use flashes on the handset.

To end a speakerphone call, simply press **SPEAKER**. The **SPEAKER** and line indicators turn off.

Note: When you receive an incoming call on a line while you are talking on the speakerphone on the other line, the line indicator for the incoming call flashes. Place the current call on hold, then press the line button for the incoming call.

Using Privacy

While using the speakerphone, you can talk to someone else in the room without the person on the other end of the phone line hearing your conversation. Press and release **PRIVACY** during the call. The **SPEAKER** indicator flashes. Press **PRIVACY** again to resume your phone conversation. The indicator lights steadily.

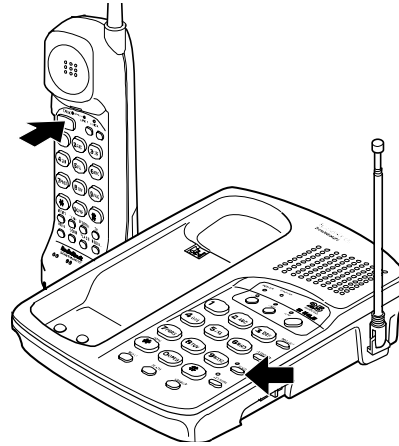

Adjusting the Speakerphone Volume

Slide **VOLUME** on the right of the base to adjust the speakerphone's volume so you can hear the other party at a comfortable level.

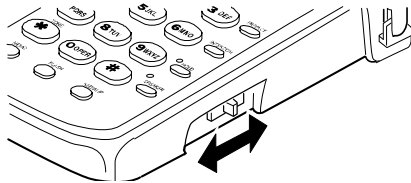

When you put a call on hold at the base, the base's **HOLD** indicator lights and the line indicator flashes on both the base and handset. When you put a call on hold at the handset, the handset's **BATT LOW** indicator turns off and the line indicator flashes on both the handset and base.

PUTTING A CALL ON HOLD

Press **HOLD** on either the handset or the base to put a call on hold. While a call is on hold, you can temporarily place the handset on the base or use the other phone line without disconnecting the current call.

The phone disconnects the call 5 minutes after you put it on hold. However, during those 5 minutes, a series of beeps reminds you the call is on hold. After 1 minute, the device (handset or base) where the line was put on hold beeps every 15 seconds. After 4 minutes, the device beeps every 5 seconds. After 5 minutes, the device sounds a long tone and disconnects the call.

To release a line from hold and continue your conversation, press that line's button. You can also release a call from hold by pressing **TALK**, picking up the handset from the base, or pressing **SPEAKER** on the base.

You can use another phone on the same line to pick up the call on hold, but the device that put the line on hold still shows that line on hold. After 5 minutes the line indicator turns off.

You can alternate between the two lines by pressing **HOLD** then the button for the desired line.

Notes:

- If you press the other line's button without first pressing **HOLD**, the first call is disconnected.
- If you place the second line on hold, the hold time restarts for the first line. Both lines automatically disconnect after 5 minutes.
- A call on hold does not automatically disconnect as long as you are talking on the second line on the same device (handset or speakerphone). The hold time restarts when you hang up the second line.
- If you place both lines on hold and then press **TALK**, pick up the handset from the base, or press **SPEAKER**, the line you dialed last is released from hold and the line you dialed first remains on hold.

SWITCHING BETWEEN THE HANDSET AND SPEAKERPHONE

To switch to the speakerphone while you are using the handset, press **HOLD** on the handset, then press **SPEAKER** or **LINE 1** or **LINE 2** on the base.

To switch to the handset while you are using the speakerphone, press **HOLD** on the base, then lift the handset off the base.

Or, if the handset is off the base, press **HOLD** on the base, then press **TALK** or **LINE 1** or **LINE 2** on the handset.

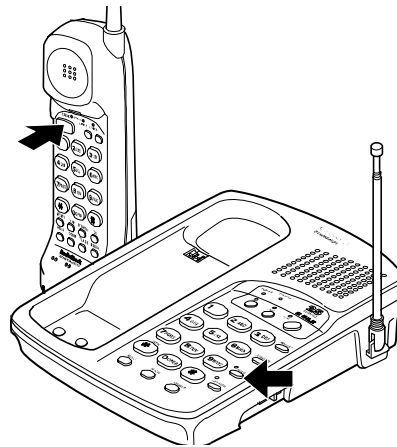

Using Both the Handset and Speakerphone

If you make or answer a call using one keypad (speakerphone or handset), someone else can press the corresponding line button on the other keypad and join the conversation.

During the call, one of you can hang up and the call can continue at the other keypad.

Note: If you hear a high-pitched noise from the base's speaker, the handset and the base are too close together.

To talk with two parties using both outside lines, see "Making a Conference Call."

MAKING A CONFERENCE CALL

Follow these steps to make a 3-way conference call.

1. Place the first call on hold.
2. Make or answer a call on the other line.

Note: Be sure to wait until the other party answers when you make a call before proceeding to Step 3. If you press **CONF** before the other party answers, the call might not be connected.

3. Press **CONF**. The BATT LOW indicator briefly flashes, then you can talk with both parties.

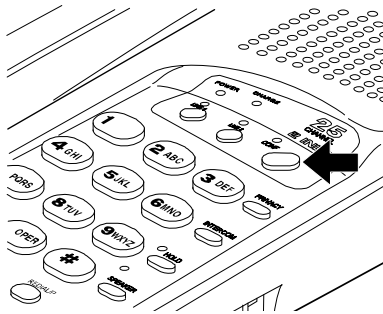

To start a 4-way conference call (two outside lines, handset, and speakerphone), first establish the 3-way conference call, then press either line button on the other keypad.

If you and someone else are already talking to an outside line using both the handset and speakerphone, *the person at the handset* should place the current call on hold, press the vacant line button, then make the call. Then, *after* the called party answers, press **INTERCOM**. After the person at the base presses **SPEAKER** to answer the intercom, press **CONF** to join all four parties.

To end the conference call, press **TALK**, return the handset to the base, or press **SPEAKER** on the base.

If you want to hang up one line and continue talking on the other, press **HOLD** to put both lines on hold, press the line button for the line you want to hang up, then press the line button for the line you want to keep.

USING REDIAL

REDIAL/P lets you quickly dial the last number dialed on either LINE 1 or LINE 2. When you hear a dial tone, simply press **REDIAL/P**.

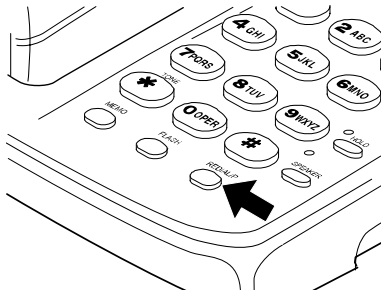

Notes:

- The redial memory is independent for each keypad. You cannot redial a number you dialed on the handset keypad using **REDIAL/P** on the base keypad, and vice versa.
- The redial memory holds up to 32 digits, so you can redial long-distance as well as local numbers.
- The redial memory also holds pause entries. See "Entering a Pause" on Page 23.
- The redial memory does not store a flash entry or any digits you press after **FLASH** (see "Using Flash").

USING FLASH

FLASH performs the electronic equivalent of a switchhook operation for special services, such as Call Waiting.

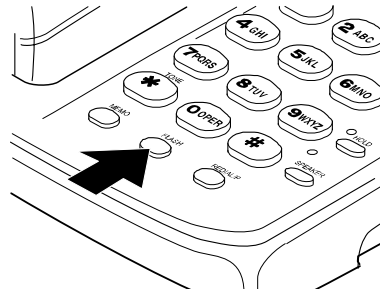

For example, if you have Call Waiting, press **FLASH** to answer an incoming call without disconnecting the current call. Press **FLASH** again to return to the first call.

Note: If you do not have any special services, pressing **FLASH** might disconnect the current call.

USING TONE SERVICES ON A PULSE LINE

Some special services, such as bank-by-phone, require tone signals. If you have pulse service, you can still use these special tone services by following these steps.

1. Be sure **P••T** is set to **P**.
2. Dial the service's main number.

- When the service answers, press **TONE/***. Any additional numbers you dial are sent as tone signals.

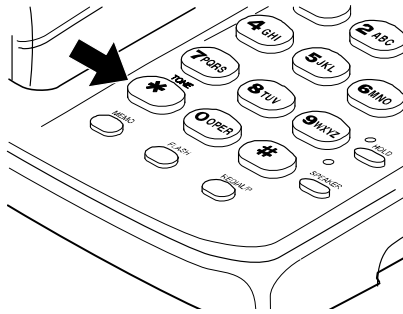

- After you complete the call, return the handset to the base, and press **TALK** on the handset or **SPEAKER** on the base. The phone automatically resets to the pulse mode.

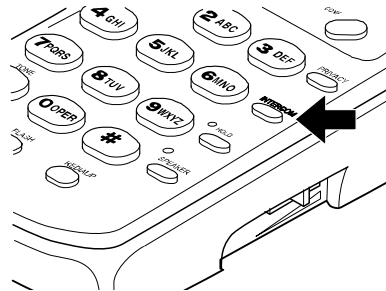

To answer the page, press **TALK** or **INTERCOM** (on the handset) or **SPEAKER** or **INTERCOM** (on the base). To end the intercom call, press **TALK** or **SPEAKER** or **INTERCOM** (on the handset or the base) or hang up the handset.

During a call, you can page someone at either the base or the handset to join the conversation. Press **INTERCOM**. The current call is put on hold. When the person at the base or handset answers, tell them to press **SPEAKER** or **TALK** once to end the intercom call then **CONF** to join the conversation.

USING THE PAGING/ INTERCOM FEATURES

You can use the ET-598 as a two-way pager and intercom between the base and the handset. This is useful if the handset is away from the base and you want to locate it, or if you want to have a conversation between the handset and the base.

To page the base or handset, press **INTERCOM**. Both the base and the handset ring.

Notes:

- The intercom does not operate if the called party is on a call.
- If a call comes in during an intercom conversation, either of the intercom parties can answer the call as they normally would. Press **TALK** on the handset or **SPEAKER** on the base once to end the intercom call, then press **TALK** or **SPEAKER** again to receive the incoming call.

MEMORY DIALING

You can store up to 20 numbers in memory (10 in the handset's memory and another 10 in the base's memory), then dial a stored number by pressing a one-digit memory location number.

Notes:

- Each number you store can be up to 16 digits long.
- You cannot dial a number stored in one memory location (the base or the handset) using the keypad on the other.

Storing a Number in Memory

Notes:

- If you wait more than 20 seconds between each key press, an error tone sounds and the phone exits the programming mode.
 - To store a number in the base's memory, start with Step 2.
1. To store a number in the handset's memory, lift the handset. If you hear a dial tone, press **TALK** to turn it off.
 2. Press **MEMO**. The BATT LOW indicator blinks on the handset or the SPEAKER indicator blinks on the base.

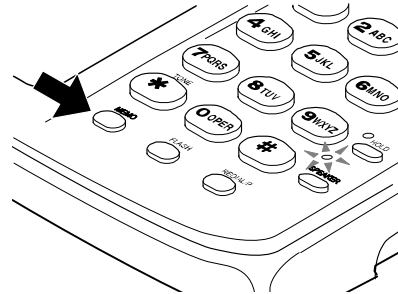

3. Enter the number and any **TONE** and **PAUSE** entries (see "Using Tone Services on a Pulse Line" on Page 20 and "Entering a Pause" on Page 23).

Note: Each **TONE** or **PAUSE** entry uses one digit of memory.

4. Press **MEMO**, then enter the memory location number (**0–9**). A single tone sounds to indicate that the number is stored.

If the phone sounds five quick beeps, you have made an entry error and the number was not stored. Start again from Step 2.

5. For each stored number, write the person's or company's name next to the appropriate location number on the supplied MEMORY directory sticker. (Use a pencil in case you want to change the number later.) Attach the sticker to the handset.

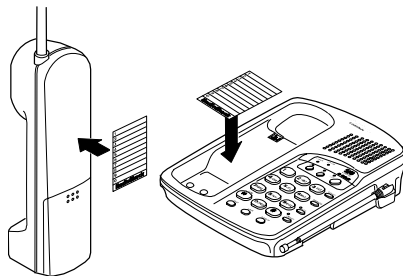

To erase a stored number, simply store a new number in its place. Or, press **MEMO** twice, then press the memory location number (**0–9**) you want to clear. A tone sounds.

Entering a Pause

In some telephone systems, you must dial an access code (**9**, for example) and wait for a second dial tone before you can dial an outside number. You can store the access code with the phone number. However, you should also store a pause after the access code to allow the outside line time to connect.

To enter a 2-second pause, press **REDIAL/P**. For a longer pause, press **REDAIL/P** additional times.

Dialing a Memory Number

To dial a number stored in the handset's memory, lift the handset from the cradle or press **TALK**. When you hear a dial tone, press **MEMO** and enter the memory location number for the number you want to dial.

To dial a number stored in the base's memory, press **SPEAKER**. When you hear a dial tone, press **MEMO** and enter the memory location number for the number you want to dial.

Chain-Dialing Service Numbers

When calling special services (such as alternate long distance or bank-by-phone), dial the service's main number first. Then, at the appropriate place in the call, press **MEMO** and the number for the memory location where the additional information is stored.

Testing Stored Emergency Numbers

If you store an emergency service's number (police department, fire department, ambulance) and you choose to test the stored number, make the test call during the late evening or early morning hours to avoid peak demand periods. Also, remain on the line to explain the reason for your call.

TROUBLESHOOTING

We do not expect you to have any problems with your phone, but if you do, the following suggestions might help.

Problem	Suggestion
Low volume or unusual sounds.	Someone has picked up another phone on the same line. Hang up the other phone.
Severe noise interference.	<ul style="list-style-type: none"> • Keep the handset and base away from computers, remote control toys, wireless microphones, alarm systems, intercoms, room monitors, fluorescent lights, and electrical appliances. • Press CH to change the channel. • Move to another location or turn off the source of interference.
The phone cannot be operated at a useful distance from the base because the signal becomes weak or noisy (handset's range has decreased).	<ul style="list-style-type: none"> • Fully extend the base's antenna in a vertical position. • Be sure neither antenna is touching a metal surface. • Return the handset to the base to recharge the battery pack.
The phone does not work or works poorly.	Be sure the base's phone line cord and AC adapter are correctly and securely connected, and the battery pack is connected and charged.
The handset battery pack does not charge.	<ul style="list-style-type: none"> • Check the charging contacts on the handset and base. If they are dirty, clean them with a pencil eraser. • Be sure the battery pack is connected correctly. • Replace the battery pack (see "Replacing the Battery Pack" on Page 27).

Problem	Suggestion
Handset does not ring or receive a page.	<ul style="list-style-type: none">• Lift the base's antenna to a fully vertical position.• Move the handset closer to the base.• Move the handset and base away from other electrical devices.• Return the handset to the base to recharge the battery pack.
The handset stops working or works poorly during a call.	<ul style="list-style-type: none">• Fully extend the base's antenna, and place it in a vertical position.• Move the handset closer to the base.• Be sure the handset's battery pack is charged. (If the battery power is too low, it does not have enough power to light the BATT LOW indicator.)• If the base loses power while the handset is off of it, the security access-protection code might change. Restore power to the base, then place the handset back on the base and leave it there for a few seconds.
The call is too noisy.	Change channels, or hang up and redial the number.

If you still have problems, disconnect the phone. If other phones on the same line work properly, the fault is in this phone or its installation. If you cannot find the problem, take your phone to your local RadioShack store for assistance.

CARE AND MAINTENANCE

Your RadioShack ET-598 25-Channel Two-Line Cordless Telephone with Dual Keypads is an example of superior design and craftsmanship. The following suggestions will help you care for your cordless telephone so you can enjoy it for years.



Keep the phone dry. If it gets wet, wipe it dry immediately. Liquids might contain minerals that can corrode the electronic circuits.



Use and store the phone only in normal temperature environments. Temperature extremes can shorten the life of electronic devices(, damage batteries,) and distort or melt plastic parts.



Keep the phone away from dust and dirt, which can cause premature wear of parts.



Handle the phone gently and carefully. Dropping it can damage circuit boards and cases and can cause the phone to work improperly.



Wipe the phone with a damp cloth occasionally to keep it looking new. Do not use harsh chemicals, cleaning solvents, or strong detergents to clean the phone.

Modifying or tampering with the telephone's internal components can cause a malfunction and might invalidate your telephone's warranty and void your FCC authorization to operate it. If your phone is not performing as it should, take it to your local RadioShack store for assistance. If the trouble is affecting the phone lines, the phone company might ask you to disconnect your phone until you have resolved the problem.

REPLACING THE BATTERY PACK

If you follow the instructions in “Connecting and Charging the Battery Pack” on Page 12, the battery pack should last about a year. If the battery pack will not hold a charge for more than 2 hours after an overnight charge, replace it with a new 3.6 V, 300 mA AH battery pack with a connector that fits the socket in the battery compartment. You can order a replacement battery pack through your local RadioShack store.

Install the new battery pack as described below, then charge the battery pack for 14 hours before you use it.

Note: To avoid losing phone numbers stored in memory, try to install and begin charging the new battery pack within 1 minute after removing the old one.

1. Remove the screw from the battery compartment cover on the bottom of the handset, then press down and slide off the cover.

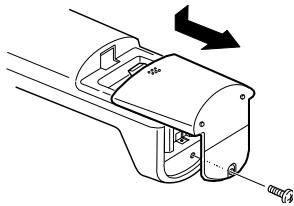

2. Gently pull on the battery connector to disconnect it, then remove the battery pack.

3. Insert a fresh battery pack and plug its connector into the socket inside the battery compartment.
4. Replace the cover and secure it with the screw.

Cautions:

- You must use a replacement battery pack of the same size and type.
- Do not dispose of the battery pack in a fire because it might explode.
- Do not open or mutilate the battery pack.
- Be careful not to short the battery pack by touching it with conducting materials, such as rings, bracelets, and keys. The battery pack or conductor might overheat and burn.

Important: This product contains a rechargeable nickel cadmium battery pack. At the end of the battery pack's useful life, it must be recycled or disposed of properly. Contact your local, county, or state hazardous waste management authorities for information on recycling or disposal programs in your area. Some options that might be available are: municipal curb-side collection, drop-off boxes at retailers such as your local RadioShack store, recycling collection centers, and mail-back programs.

THE FCC WANTS YOU TO KNOW

In the unlikely event that your phone causes problems on the phone line, the phone company can temporarily discontinue your service. If this happens, the phone company attempts to notify you in advance. If advance notice is not practical, the phone company notifies you as soon as possible and advises you of your right to file a complaint with the FCC.

Also, the phone company can make changes to its lines, equipment, operations, or procedures that could affect the operation of this telephone. The telephone company notifies you of these changes in advance, so you can take the necessary steps to prevent interruption of your telephone service.

Your phone might cause TV or radio interference even when it is operating properly. To determine whether your phone is causing the interference, turn off your phone. If the interference goes away, your phone is causing the interference.

Try to eliminate the interference by:

- Moving your phone away from the receiver
- Connecting your phone to an AC outlet that is on a different electrical circuit from the receiver
- Contacting your local RadioShack store for help

If you cannot eliminate the interference, the FCC requires that you stop using your phone.

Some cordless phones operate at frequencies that might cause interference to nearby TVs and VCRs. To minimize or prevent such interference, the base of the cordless phone should not be placed near or on top of a TV or VCR.

LIGHTNING

Your telephone has built-in lightning protection to reduce the risk of damage from surges in telephone line and power line current. This lightning protection meets or exceeds FCC requirements. However, lightning striking the telephone or power lines can damage your telephone.

Lightning damage is not common. Nevertheless, if you live in an area that has severe electrical storms, we suggest that you unplug your phone during storms to reduce the possibility of damage.

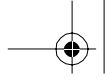

NOTES

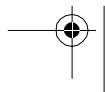
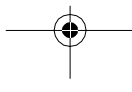
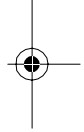
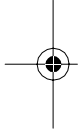

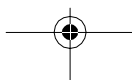
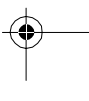
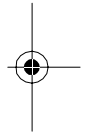

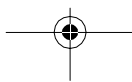

Limited One-Year Warranty

This product is warranted by RadioShack against manufacturing defects in material and workmanship under normal use for one (1) year from the date of purchase from RadioShack company-owned stores and authorized RadioShack franchisees and dealers. EXCEPT AS PROVIDED HEREIN, RadioShack MAKES NO EXPRESS WARRANTIES AND ANY IMPLIED WARRANTIES, INCLUDING THOSE OF MERCHANTABILITY AND FITNESS FOR A PARTICULAR PURPOSE, ARE LIMITED IN DURATION TO THE DURATION OF THE WRITTEN LIMITED WARRANTIES CONTAINED HEREIN. EXCEPT AS PROVIDED HEREIN, RadioShack SHALL HAVE NO LIABILITY OR RESPONSIBILITY TO CUSTOMER OR ANY OTHER PERSON OR ENTITY WITH RESPECT TO ANY LIABILITY, LOSS OR DAMAGE CAUSED DIRECTLY OR INDIRECTLY BY USE OR PERFORMANCE OF THE PRODUCT OR ARISING OUT OF ANY BREACH OF THIS WARRANTY, INCLUDING, BUT NOT LIMITED TO, ANY DAMAGES RESULTING FROM INCONVENIENCE, LOSS OF TIME, DATA, PROPERTY, REVENUE, OR PROFIT OR ANY INDIRECT, SPECIAL, INCIDENTAL, OR CONSEQUENTIAL DAMAGES, EVEN IF RadioShack HAS BEEN ADVISED OF THE POSSIBILITY OF SUCH DAMAGES.

Some states do not allow the limitations on how long an implied warranty lasts or the exclusion of incidental or consequential damages, so the above limitations or exclusions may not apply to you.

In the event of a product defect during the warranty period, take the product and the RadioShack sales receipt as proof of purchase date to any RadioShack store. RadioShack will, at its option, unless otherwise provided by law: (a) correct the defect by product repair without charge for parts and labor; (b) replace the product with one of the same or similar design; or (c) refund the purchase price. All replaced parts and products, and products on which a refund is made, become the property of RadioShack. New or reconditioned parts and products may be used in the performance of warranty service. Repaired or replaced parts and products are warranted for the remainder of the original warranty period. You will be charged for repair or replacement of the product made after the expiration of the warranty period.

This warranty does not cover: (a) damage or failure caused by or attributable to acts of God, abuse, accident, misuse, improper or abnormal usage, failure to follow instructions, improper installation or maintenance, alteration, lightning or other incidence of excess voltage or current; (b) any repairs other than those provided by a RadioShack Authorized Service Facility; (c) consumables such as fuses or batteries; (d) cosmetic damage; (e) transportation, shipping or insurance costs; or (f) costs of product removal, installation, set-up service adjustment or reinstallation.

This warranty gives you specific legal rights, and you may also have other rights which vary from state to state.

RadioShack Customer Relations, Dept. W, 100 Throckmorton St., Suite 600, Fort Worth, TX 76102

We Service What We Sell

3/97

RadioShack
A Division of Tandy Corporation
Fort Worth, Texas 76102

UDZZ01503ZA
Printed in Hong Kong

10A7