

TANDBERG 3G Gateway

User Manual



Software version R1.0
D13841.01

This document is not to be reproduced in whole or in part without permission in writing from:

TANDBERG

Trademarks and copyright

All rights reserved. This document contains information that is proprietary to TANDBERG. No part of this publication may be reproduced, stored in a retrieval system, or transmitted, in any form, or by any means, electronically, mechanically, by photocopying, or otherwise, without the prior written permission of TANDBERG. Nationally and internationally recognized trademarks and trade names are the property of their respective holders and are hereby acknowledged.

Copyright (c) 1992, 1993, The Regents of the University of California. All rights reserved. This code is derived from software contributed to Berkeley by Christos Zoulas of Cornell University. Redistribution and use in source and binary forms, with or without modification, are permitted provided that the following conditions are met:

- Redistributions of source code must retain the above copyright notice, this list of conditions and the following disclaimer.
- Redistributions in binary form must reproduce the above copyright notice, this list of conditions and the following disclaimer in the documentation and/or other materials provided with the distribution.
- All advertising materials mentioning features or use of this software must display the following acknowledgement:
 - This product includes software developed by the University of California, Berkeley and its contributors.
- Neither the name of the University nor the names of its contributors may be used to endorse or promote products derived from this software without specific prior written permission.

This software is provided by the Regents and contributors 'as is' and any express or implied warranties, including, but not limited to, the implied warranties of merchantability and fitness for a particular purpose are disclaimed. In no event shall the Regents or contributors be liable for any direct, indirect, incidental, special, exemplary, or consequential damages (including, but not limited to, procurement of substitute goods or services; loss of use, data or profits; or business interruption) however caused and on any theory of liability, whether in contract, strict liability, or tort (including negligence or otherwise) arising in any way out of the use of this software, even if advised of the possibility of such damage.

Disclaimer

The information in this document is furnished for informational purposes only, it is subject to change without prior notice, and should not be construed as a commitment by TANDBERG. The information in this document is believed to be accurate and reliable, however TANDBERG assumes no responsibility or liability for any errors or inaccuracies that may appear in this document, nor for any infringements of patents or other rights of third parties resulting from its use. No license is granted under any patents or patent rights of TANDBERG.

This document was written by the Research and Development Department of TANDBERG, Norway. We are committed to maintain a high level of quality in all our documentation. Towards this effort, we welcome you to [Contact us](#) with comments and suggestions regarding the content and structure of this document.

COPYRIGHT © 2005, TANDBERG

Environmental Issues

Thank you for buying a product which contributes to a reduction in pollution, and thereby helps save the environment. Our products reduce the need for travel and transport and thereby reduce pollution. Our products have either none or few consumable parts (chemicals, toner, gas, paper). Our products are low energy consuming products.

TANDBERG's Environmental Policy

- TANDBERG's Research and Development is continuously improving TANDBERG's products towards less use of environmentally hazardous components and substances as well as to make the products easier to recycle.
- TANDBERG's products are Communication Solutions. The idea of these solutions is to reduce the need for expensive, time demanding and polluting transport of people. Through people's use of TANDBERG's products, the environment will benefit from less use of polluting transport.
- TANDBERG's wide use of the concepts of outsourcing makes the company itself a company with a low rate of emissions and effects on the environment.
- TANDBERG's policy is to make sure our partners produce our products with minimal influence on the environment and to demand and audit their compatibility according to applicable agreements and laws (national and international).

Environmental Considerations

Like other electronic equipment, the TANDBERG 3G Gateway contains components that may have a detrimental effect on the environment. TANDBERG works continuously towards eliminating these substances in our products.

- Printed-wiring boards made of plastic, with flame-retardants like Chloride or Bromide.
- Component soldering that contains lead.
- Smaller components containing substances with possible negative environmental effect.

After the product's end of life cycle, it should be returned to authorized waste handling and should be treated according to National and International Regulations for waste of electronic equipment.

Operator Safety Summary

For your protection, please read these safety instructions completely before operating the equipment and keep this manual for future reference. The information in this summary is intended for operators. Carefully observe all warnings, precautions and instructions both on the apparatus and in the operating instructions.

Warnings

- Caution risk of explosion if battery is replaced by an incorrect type. Dispose of used batteries according to the instructions.
- Water and moisture - Do not operate the equipment under or near water - for example near a bathtub, kitchen sink, or laundry tub, in a wet basement, or near a swimming pool or in areas with high humidity.
- Cleaning - Unplug the apparatus from the wall outlet before cleaning or polishing. Do not use liquid cleaners or aerosol cleaners. Use a lint-free cloth lightly moistened with water for cleaning the exterior of the apparatus.
- Ventilation - Do not block any of the ventilation openings of the apparatus. Install in accordance with the installation instructions. Never cover the slots and openings with a cloth or other material. Never install the apparatus near heat sources such as radiators, heat registers, stoves, or other apparatus (including amplifiers) that produce heat.
- Grounding or Polarization - Do not defeat the safety purpose of the polarized or grounding-type plug. A polarized plug has two blades with one wider than the other. A grounding type plug has two blades and a third grounding prong. The wide blade or third prong is provided for your safety. If the provided plug does not fit into your outlet, consult an electrician.
- Power-Cord Protection - Route the power cord so as to avoid it being walked on or pinched by items placed upon or against it, paying particular attention to the plugs, receptacles, and the point where the cord exits from the apparatus.
- Attachments - Only use attachments as recommended by the manufacturer.
- Accessories - Use only with a cart, stand, tripod, bracket, or table specified by the manufacturer, or sold with the apparatus. When a cart is used, use caution when moving the cart/apparatus combination to avoid injury from tip-over.
- Lightning - Unplug this apparatus during lightning storms or when unused for long periods of time.
- Servicing - Do not attempt to service the apparatus yourself as opening or removing covers may expose you to dangerous voltages or other hazards, and will void the warranty. Refer all servicing to qualified service personnel.
- Damaged Equipment - Unplug the apparatus from the outlet and refer servicing to qualified personnel under the following conditions:
 - When the power cord or plug is damaged or frayed
 - If liquid has been spilled or objects have fallen into the apparatus
 - If the apparatus has been exposed to rain or moisture
 - If the apparatus has been subjected to excessive shock by being dropped, or the cabinet has been damaged
 - If the apparatus fails to operate in accordance with the operating instructions

Contact us

If you have any questions, comments or suggestions, please see the [Online Support](#) service at www.tandberg.net.

It is also possible to send a fax or mail to the attention of:

Product and Sales Support
TANDBERG
P.O. Box 92
1325 Lysaker
Norway
Tel: +47 67 125 125
Fax: +47 67 125 234

Table of Contents

1	Introduction.....	8
1.1	The TANDBERG 3G Gateway.....	10
1.1.1	3G GATEWAY Capacity – typical scenarios	11
2	Installation	12
2.1	Unpacking	13
2.2	Connecting cables	14
2.3	3G Gateway Configuration.....	15
3	Using the 3G Gateway	18
3.1	Call Overview	18
3.2	Dial from UMTS.....	20
3.3	Dial from IP	23
4	View System Status	25
4.1	PRI/BRI Status	26
4.2	H.323 Status	29
4.3	System Information	30
4.4	Available Resources	31
5	Configure the Gateway.....	32
5.1	System Configuration.....	33
5.1.1	PRI Configuration.....	33
5.1.2	BRI configuration	35
5.2	IP Configuration	37
5.3	H.323 Configuration	39
5.4	SNMP Configuration	41
5.5	Miscellaneous Configuration.....	43
5.6	Software Upgrade	45
5.7	Services Configuration	47
5.7.1	IVR	49
5.7.2	examples.....	50
6	Appendices.....	51

1 Introduction

The TANDBERG 3G Gateway enables sites on IP and UMTS Handsets to participate in meetings with each other with the quality and reliability found in all TANDBERG equipment.

IP Services and Procedures

- Service Prefix
- Load balance

UMTS Services

The TANDBERG 3G Gateway offers a variety of UMTS dial-in services:

- Direct Inward Dialing (DID) - The destination endpoint is determined from the dialed number
- Interactive Voice Response (IVR) - The destination endpoint can be selected via touch tones

Security

- Secure Access - support XML/SOAP over HTTPS, Web (HTTP) encrypted password and the services that can be disabled

Video Quality

- H.263 video compression

Audio Quality

- AMR, G.711 audio compression
- Support AMR bitrate 4.75 kbit – 12.2 kbit

Interoperability

- Worldwide compatibility with standards-based videoconferencing systems
- Compatible with all available WCDMA H324M video telephony capable handsets who support DTMF tones

Management Interfaces

SOAP Simple Object Access Protocol is a lightweight protocol for exchange of information in a decentralized, distributed environment

XML Extensible Markup Language is a flexible way to create common information formats and share both the format and the data on the World Wide Web, intranets, and elsewhere. This functionality can be used by management systems like the TANDBERG Management Suite to control the 3G Gateway

HTTP Web-interface for system management, call management such as call transfer, diagnostics and software uploads

HTTPS Hypertext Transfer Protocol over Secure Socket Layer is a Web protocol that encrypts and decrypts user page requests as well as the pages that are returned by the Web server. It uses Secure Socket Layer (SSL) as a sublayer under its regular HTTP application layering. HTTPS uses port 443 instead of HTTP port 80 in its interactions with the lower layer, TCP/IP. SSL uses a 40-bit key size for the RC4 stream encryption

algorithm, which is considered an adequate degree of encryption for commercial exchange

Network and Features

- Up to 30 video sites can be connected at the same time
- Call rate of 64 Kbit on ISDN side and 109kbps on IP side for each call is supported through the 3G Gateway
- Video IVR
- Selecting IP endpoint from address book

1.1 The TANDBERG 3G Gateway

Front view

The front panel provides 4 LAN interfaces, an LCD display, RS232 interface and control buttons.



Rear view

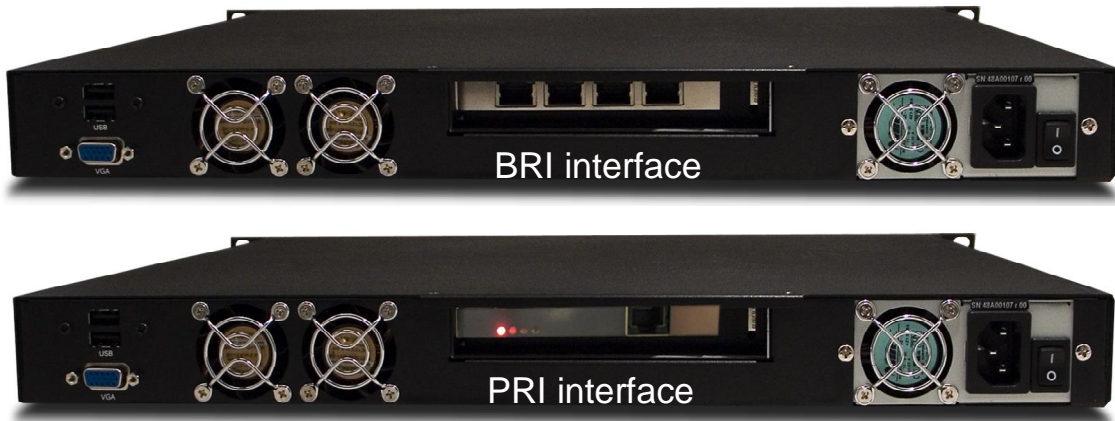

The back panel provides one PRI interface or 4 BRI interfaces depending on the configuration and one power switch/connector. Next to the PRI RJ-45 there are 4 LED's. In normal working condition the green LED will be lit. Functions of the LED's are:

Green: Normal operation

Red Alarm or Loss of signal (LOS) indicates that there is no signal and thus no framing info received. The same effect will be obtained by pulling out the PRI cable. This may also be caused by a broken connector in the receive (RX) part of the cable.

Yellow Alarm or Remote Alarm Indicator (RAI) means that the 3G Gateway is receiving framing info, but in this framing info the other side tells the 3G Gateway that it is not reading the gateway's transmitted framing info. Typically, this may be a broken connector in the transmit (TX) part of the PRI cable. This could also indicate weak or noisy signal in the transmit (TX) part of the PRI cable.

Blue Alarm indicates that the received frames are not synchronized properly.

No LED's lite indicates that layer one framing is working (right protocol like for example EURO ISDN selected), but that however there is a problem at layer 2 caused by for example a CRC4 configuration mismatch.

1.1.1 3G GATEWAY Capacity – typical scenarios

Due to the fixed bandwidth of UMTS video telephony every call will be limited to 64 kbit. This offers a capacity of 30 simultaneous calls through a single PRI 3G Gateway or 8 calls through a 4 x BRI 3G Gateway. Due to audio transcoding (AMR to G.711) the bandwidth at IP side is 109 kbit/s per session, 64 Kbit G.711 audio and 45 kbit H.263 video. Depending on the option package and version of the 3G Gateway (PRI or BRI) the amount of simultaneous 3G calls can be less than 30 or 23 for T1.

2 Installation

Precautions:

- Never install telephone wiring during a lightning storm.
- Never install telephone jacks in wet locations unless the jack is specifically designed for wet locations.
- Never touch uninstalled telephone wires or terminals unless the telephone line has been disconnected at the network interface.
- Use caution when installing or modifying telephone lines.
- Avoid using a telephone (other than a cordless type) during an electrical storm. There may be a remote risk of electrical shock from lightning.
- Do not use the telephone to report a gas leak in the vicinity of the leak.
- The socket outlet shall be installed near to the equipment and shall be easily accessible.
- Never install cables without first switching the power OFF.
- This product complies with directives: LVD 73/23/EC, EMC 89/366/EEC, R&TTE 99/5/EEC.
- This product complies with the standards GR-63-CORE and GR-1089-CORE and is NEBS approved by UL .For NEBS compliance, the product should be installed in the following manner:
 - There should be a clearance of 9.1cm between the product and any other product mounted in the rack.

2.1 Unpacking

To avoid damage to the unit during transportation, the 3G Gateway is delivered in a special shipping box, which should contain the following components:

- User Manual and other documentation on CD.
- Rack-ears, screws and screwdriver.
- Cables:
 - Power cable
 - One ISDN PRI cables or 4 ISDN BRI cables depending on the version
 - Ethernet cable
 - RS232 cable
- TANDBERG 3G Gateway

Installation site preparations

- Make sure that the 3G Gateway is accessible and that all cables can be easily connected.
- For ventilation: Leave a space of at least 10cm (4 inches) behind the 3G Gateway's rear panel and 10cm (4 inches) in front of the front panel.
- The room in which you install the 3G Gateway should have an ambient temperature between 0°C and 35°C (32°F and 95°F) and between 10% and 90% non-condensing relative humidity.
- Do not place heavy objects directly on top of the 3G Gateway.
- Do not place hot objects directly on top, or directly beneath the 3G Gateway.
- Use a grounded AC power outlet for the 3G Gateway.
- You will need a CSU (Channel Service Unit) between your system and the PRI line from your network provider.
- Make sure that it is possible to receive and to make Mobile(h324M) video calls from behind this line. Check this with your network operator!
- If you are behind a PABX make sure that the PBABX is capable of routing Mobile (H324M) video calls.

2.2 Connecting cables

Power cable

Connect the system power cable to an electrical distribution socket.

ISDN PRI or BRI cables

The E1/T1 cable should be connected to a CSU (Channel Service Unit). You will need a CSU between your 3G Gateway and the PRI line from your network provider.

LAN cable

To use the 3G Gateway on IP, connect a LAN cable from the 'LAN 1' connector on the 3G Gateway to your network. The 'LAN 2, 3 and 4' connectors are not used and should be left open.

RS 232 cable

To control the 3G Gateway using the dataport, connect an RS 232 cable between the 3G Gateway's RS 232 connector and the COM-port on a PC.

2.3 3G Gateway Configuration

The 3G Gateway requires some basic configurations before it can be used. It will be necessary to find the IP-address and to create the dial-in and dial-out services program the ISDN-PRI Line numbers.

It is possible to use the front panel LCD display or the serial RS232 cable. Using the RS232 cable, follow the instructions below:

1. Connect the RS232 cable between the 3G Gateway and a PC and then switch on the 3G Gateway.
2. Start a terminal program on the PC and configure it to: 115200, 8, 1, None.
3.
 - a. To assign a static IP-address, type 'Xconf ip Assignment: "Static" ' and 'Xconf Ip address <IPAddr>'.
 - b. To assign an IP Subnetmask, type 'Xconf ip address subnetmask <subnetmask>'.
 - c. To assign an IP Gateway address, type 'Xconf ip address gateway <gateway IP-address>'.
4. Restart the 3G Gateway.
5. Start a WEB browser and enter the IP-address of the 3G Gateway. Default password: 'TANDBERG'.
6. To configure the 3G Gateway for UMTS dial in, enter PRI or BRI numbers and dial in number(s). For details, see the 'PRI Configuration' and the 'Services Configuration' section.
7. To configure the gateway for IP dial in, register the gateway to a gatekeeper and enter H.323 services. For details, see chapter 5.7, Services Configuration..

The LCD panel makes it possible to configure and the Check the IP settings and to reboot the system. The front panel LCD menu items are displayed below. Due to the limited amount of buttons the function will differ on every menu level also depending on the function of the menu (reading or editing). Appendix 0 contains a detailed description of every level and functions of every button. The usage of the buttons is designed in an intuitive way and should not result in any problems.

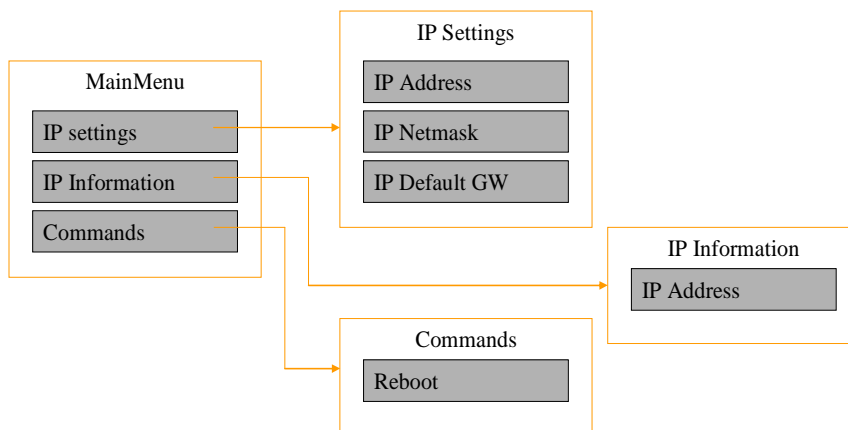

To configure the IP number follow the instructions below:

1. Press any key to get the main menu.
2. IP settings should be displayed.
3. Press [ENTER] to access the IP settings menu.
4. Use the [UP/DOWN] key to select IP Address.
5. Press [ENTER] to access the IP address editing menu.
6. Press [ENTER] again to get a cursor.
7. Use up down keys to navigate between the different digits.
8. After selecting a digit use the [ENTER] key in combination with the [UP/DOWN] key to change the digit value.
9. When finished editing use [ESC] key to go to the confirm change menu.
10. Use the [UP/DOWN] key to select yes or no and [ENTER] to confirm.
11. Use [ESC] key to navigate back to the main menu.

Note that DHCP assigned IP-addresses are supported by the TANDBERG 3G Gateway (factory default),

3G Gateway start-up

To start the 3G Gateway, please make sure that the power cable is connected, and press the power switch button at the back side to '1'.



On the front panel of the system the power indicator LED, marked 'Pwr', will turn GREEN.

Accessing the 3G Gateway

You may access the 3G Gateway by entering the IP-address of the 3G Gateway in a standard WEB-browser. You will then be asked to enter a password. It is not necessary to enter 'User Name'. The default password for the 3G Gateway is '**TANDBERG**'. Remember that the password is case sensitive. Note that it also possible to use SSH and Telnet to configure the 3G Gateway.



Note that the password can be changed in System Configuration', Misc'. See also the section '5.5 Miscellaneous Configuration'.

3 Using the 3G Gateway

3.1 Call Overview

The following Web-page, called '**Overview**' will be shown when the correct password has been entered and shows all calls currently active through the 3G Gateway.

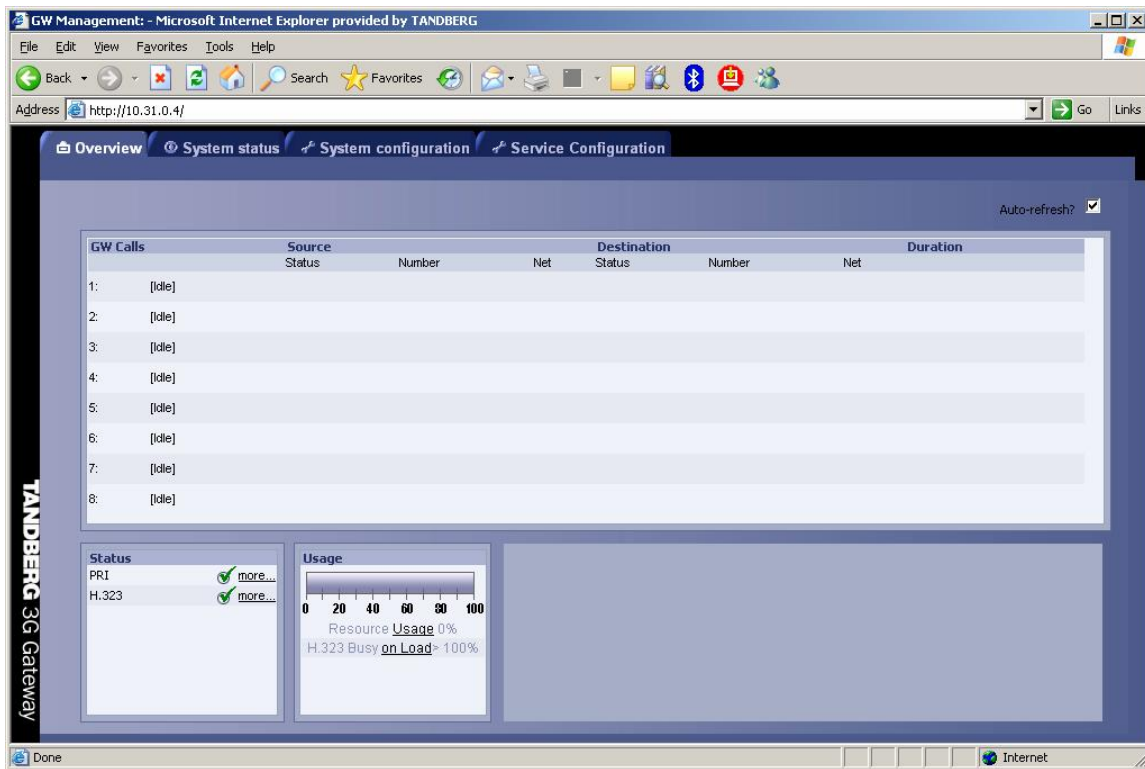

GW Calls

Shows each active call through the 3G Gateway.

[Idle] No call is active.

Active Call A call is active.

Source / Destination

Source shows the Status of the incoming call to the 3G Gateway, the number and which network the incoming call is using.

Destination shows the Status of the outgoing call from the 3G Gateway, the number and which network the outgoing call is using.

Idle	No active call, call has been disconnected.
Alerting	Call is being connected.
Connected	Call is connected.
Establ out	3G Gateway is calling out to destination.
Clear out	Call is being disconnected.
Number	ISDN or IP number.
IP/H.323	Call connected is using the H.323 protocol over IP.

Duration

Shows the length of the current call.

Status

Shows current status on the PRI and IP status.

PRI:



PRI line is synced and active. Click on More... to see status in detail.



PRI line is not active. Click on More... to see status in detail.

IP/H.323:



The gateway is registered with a Gatekeeper. Click on More... to see status in detail.



The gateway is not registered with a Gatekeeper. Click on More... to see status in detail.

Usage

The usage bar shows the current status of all the available resources (CPU, ISDN channels and number of calls)

When the Resource Usage reaches the "Busy on Load"-limit, the gatekeeper will try to route outgoing IP calls to other gateways. This is done to maintain availability for incoming UMTS calls when using multiple gateways.

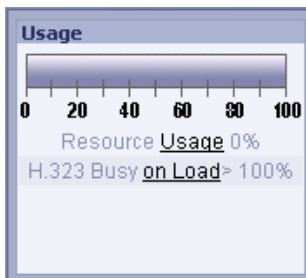

Resource Usage 90%. Click on the Usage link to see resource usage in detail.

H.323 Busy on Load > 70%. Click on the Load link to adjust the value.

3.2 Dial from UMTS

The gateway supports three different UMTS Dial In services:

- "DiD" → Direct outwards dialing of a 3G handset.
- "IVR" → Dialing 3G terminals via selection menu.
- "Phonebook" → Selecting entry from gateway phonebook

Any of these services can be enabled or disabled, but at least one must be enabled for incoming call routing to take place.

In order to enable parallel incoming calls, a PRI number range must be defined.

For more details on UMTS Dial In services, please see the section '5.7 Services'.

DID

Direct Inward Dialing (DID) will provide you with direct ISDN numbers for your IP endpoints i.e. it will do a direct mapping between your ISDN number and the H.323 Alias or vice versa. In order to use DID you will need to have assigned multiple ISDN numbers to your ISDN PRI or BRI line, as each ISDN number will map to a single IP endpoint.

Example:

- Your ISDN number range is from 67124000 to 67124050 and DID is enabled.
- You want your IP endpoints to have the numbers (H.323 Alias) in the range 94000 - 94050.
In the services Configuration, set (remove) Prefix/Nr to 67124, set Service Type to DiD and (add) Prefix/Nr to 9.
- To call an IP endpoint with H.323 Alias 94020 from ISDN, dial the ISDN number 67124020.
- The gateway starts to call the IP endpoint and the "connecting" picture and sound are activated.
- When the call is connected audio and video are transmitted through the gateway.

IVR

Interactive Voice Response (IVR), also called extension dial-in, is an automated answering system that directs the call to the IP endpoint indicated by the caller. The caller uses telephone tones (DTMF) to enter the H.323 Alias or extension.

IVR is useful if you have limited numbers on your ISDN PRI or BRI line.

Example:

- A videoconferencing system calls into the Extension Dial In number with IVR active.
- The gateway activates the 'Welcome' picture and sound.
- The videoconferencing system enters the extension (H.323 Alias) followed by the # (pound-sign) to indicate end of number.
- The gateway starts to call the IP endpoint and the "Connecting" picture and sound are activated.
- When the call is connected audio and video are transmitted through the gateway.

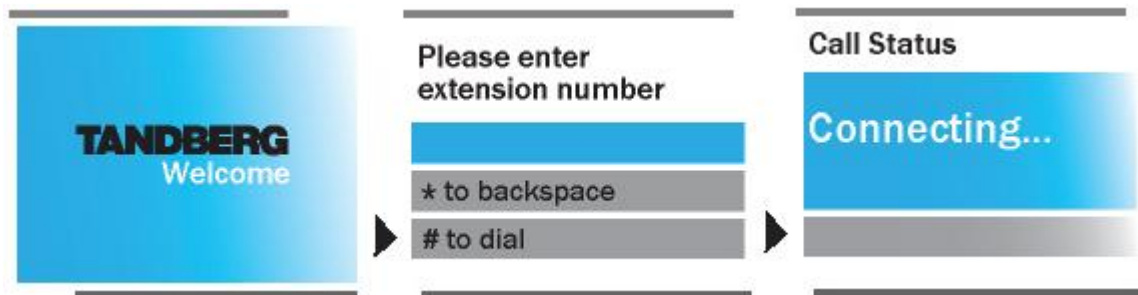

IVR Phonebook IVR Phonebook allows an UMTS phone to dial an IP endpoint directly, without knowing or having to (manually) enter the extension number via DTMF. IVR Phonebook is a dial-in method which combines a directory listing from TMS with IVR. In this mode the user can search in the global address book provided via TMS using the alphanumeric part of the keypad. The 3G Gateway supports T9 phonebook and starts displaying the 5 entries which match with the submitted characters as displayed below. Pressing 2 and 3 will result in a list with names containing the combinations 'ad', 'be', 'ce', etc. For example trying to reach Allan.Bjornstad is possible pressing the 2 and the 5 on the keyboard. This will result in a listing of names which contain 'al'. A valid list will contain both *alisdair.munro* and *anne.aalbuk*. The top name in the list is highlighted and via the pound key (#) this person will be dialed. In case the name is not listed pursue in completing the name using the T9 concept known from SMS. The star (*) key on the keyboard is used as backspace.



Example:

- An UMTS phone calls into the Extension Dial In number with IVR phonebook active. The gateway shows a menu with makes it possible to submit the name (both Christian and first name) via the alphanumeric DTRMF keys . For example finding Michel is possible via pressing 6 (m,n,o),4 ,2. The top entry in the phonebook will be highlighted and pressing '#' will starts to call the IP endpoint, the "Connecting" picture and sound are activated.
- When the call is connected audio and video are transmitted through the gateway.

Sequence of Services

To ensure best service to the incoming UMTS call, the gateway will first try to match the DID number, and then the IVR Phonebook number.

3.3 Dial from IP

IP endpoints and MCUs can call out through the gateway by using one of the services defined on the gateway. The gateway support three different dial out services:

- “DiD” → Direct outwards dialing of a 3G handset.
- “IVR” → Dialing 3G terminals via selection menu.
- “Phonebook” → Selecting entry from gateway phonebook

Services

Service prefixes are used for IP endpoints to access UMTS Handsets. Up to twenty services/prefixes can be defined, but we recommend using one single prefix for simplicity.

Example:

- An H.323 Service prefix for outgoing video calls is defined as “0”.
- The IP endpoint dials 067121212 to dial the UMTS number 67121212.
- The gateway starts to call the UMTS handset and the “Connecting” picture and sound are activated.
- Audio and video are transported through the gateway when the call is connected.

The screenshot shows the 'Service Configuration' page in the Tandberg 3G Gateway Management interface. The page is titled 'Services' and contains a table of service entries. The table has columns for 'Entry', 'Description', 'Serv. type', 'From', and 'To'. The 'From' column is further divided into 'Net type', 'Prefix', and 'Postfix'. The 'To' column is also divided into 'Net type', 'Prefix', and 'Postfix'.

Entry	Description	Serv. type	From			To		
			Net type	Prefix	Postfix	Net type	Prefix	Postfix
	Phonebook	DiD	H323	3333		H323		

Below the table, there are configuration options for a service. The 'Service type' is set to 'None'. The 'From' section has 'Net type' set to 'H324m/3G'. The 'To' section has 'Net type' set to 'H324m/3G'. There are buttons for 'Create New', 'Clear', 'Save Changes', and 'Delete'.

At the bottom of the page, there is a 'Configuration' section with 'Signal Busy on Load' set to '100 %' and a 'Save' button.

For more details on H-323 Services, please see '5.7 Services'.

Note that the bandwidth used for the call will be 109Kbit independent of the bandwidth selected on the IP endpoint, except for selecting 64 Kbit. However this will result in an audio only call.

4 View System Status

To view current gateway status, open 'System Status' as shown in the figure below.

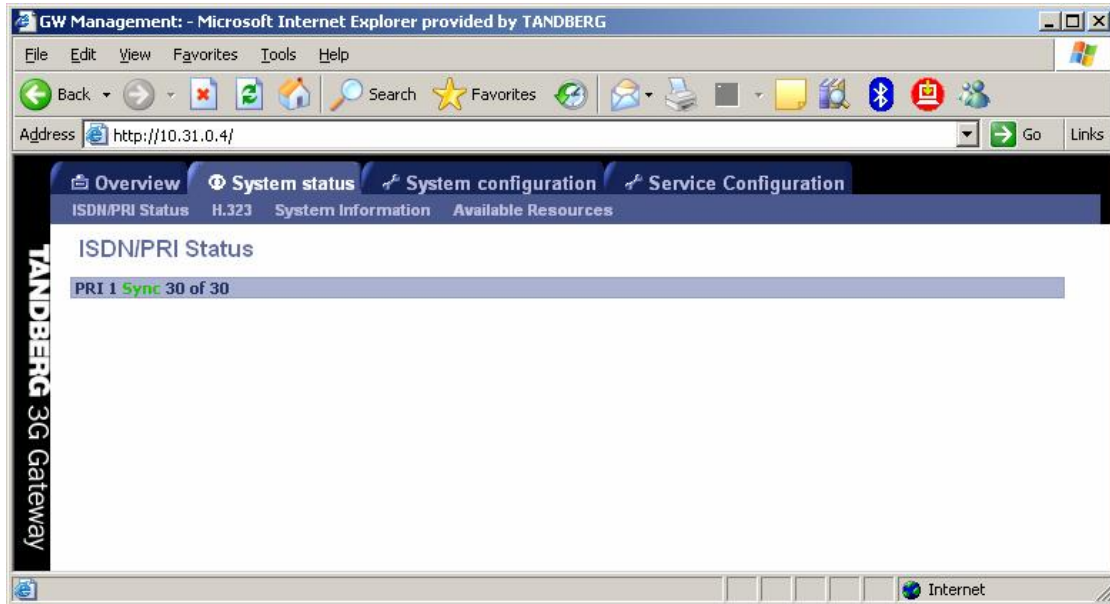

4.1 PRI/BRI Status

PRI Status

The colored part of the system status indicates the condition of the ISDN PRI line. There are three possible conditions:

- Sync 30 of 30. ISDN layer 1 and 2 are up and in sync.
- Sync 0 of 0, ISDN layer 1 and 2 are in sync but not up.
- Red Alarm, 0 of 0, ISDN layer 1 and 2 are down, most time indicating a disconnected ISDN line.

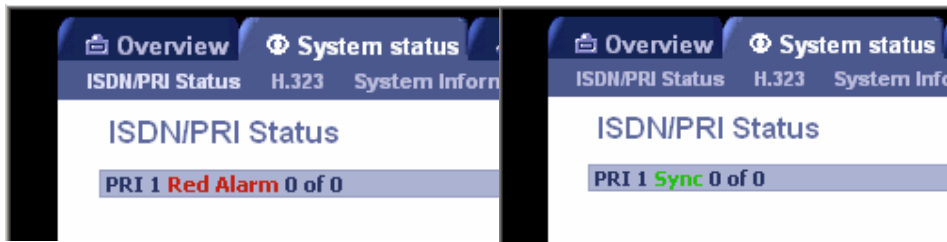

Besides the indications on the webpage the ISDN interface also contains 4 LEDs located at the back-side of the 3G Gateway.



These LED's indicate the following **PRI status**:

Green: Normal operation

Red Alarm or Loss of signal (LOS) indicates that there is no signal and thus no framing info received. The same effect will be obtained by pulling out the PRI cable. This may also be caused by a broken connector in the receive (RX) part of the cable.

Yellow Alarm or Remote Alarm Indicator (RAI) means that the gateway is receiving framing info, but in this framing info the other side tells the gateway that it is not reading the gateway's transmitted framing info. Typically, this may be a broken connector in the transmit (TX) part of the PRI cable. This could also indicate weak or noisy signal in the transmit (TX) part of the PRI cable.

Blue Alarm indicates that the received frames are not synchronized properly.

No LED's lite indicates that layer one framing is working (right protocol like for example EURO ISDN selected), but that however there is a problem at layer 2 caused by for example a CRC4 configuration mismatch

BRI Status

The picture below show the status page of a BRI version of the gateway

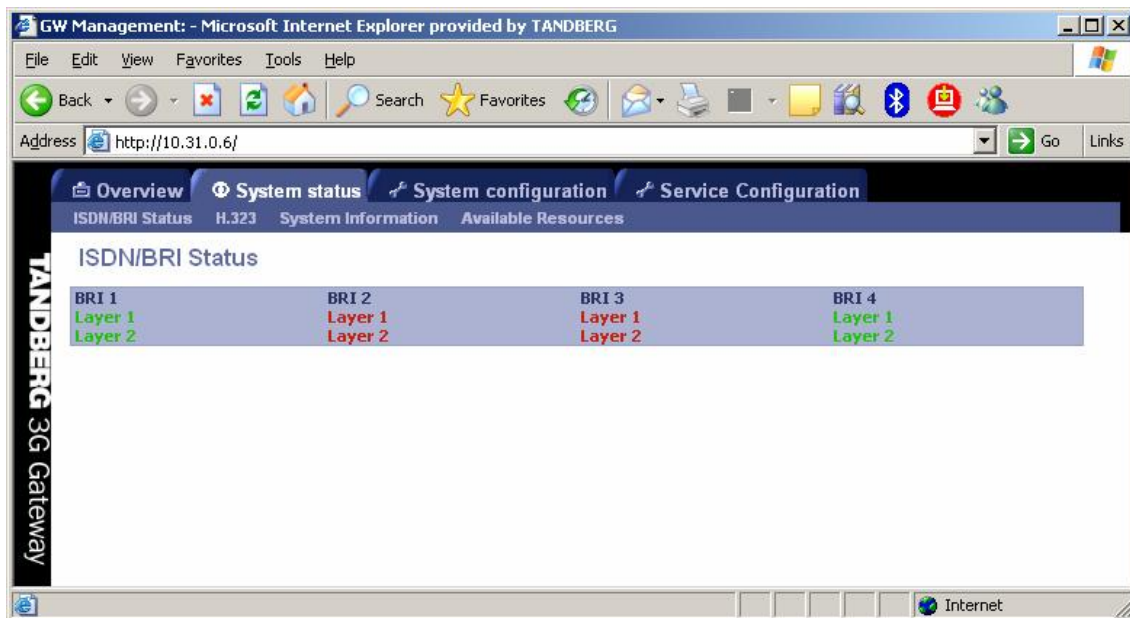

The BRI status displays the conditions of ISDN layer 1 and 2 separately. Green indicates up and in sync. Red indicates not in sync and indicate probably a disconnected ISDN line.



Besides the indications on the webpage each ISDN BRI interface located at the back-side of the 3G Gateway has a green and orange LED. The meaning of these LED's is:

Green: Layer 1 of the ISDN signaling is up

Green and Orange indicates that Both layer 1 and 2 are up. The orange LED can in some countries blink on a regular interval, or only lit when there is an active call.

No LED's lit indicates that there is a no connection or a wrong wired connection.

Note that in some countries layer 2 can be down when there is not activity (ongoing connections). However layer 2 should become active when a call is made or received.

Note that in case the BRI 3G gateway is connected with less than 4 BR lines the BRI interfaces with the highest number(s) should be left open. For example when only 2 ISDN lines are used they should be connected with interface 1 and 2.

4.2 H.323 Status

To view H.323 gatekeeper status, open 'H.323 Status' as shown in the figure below.

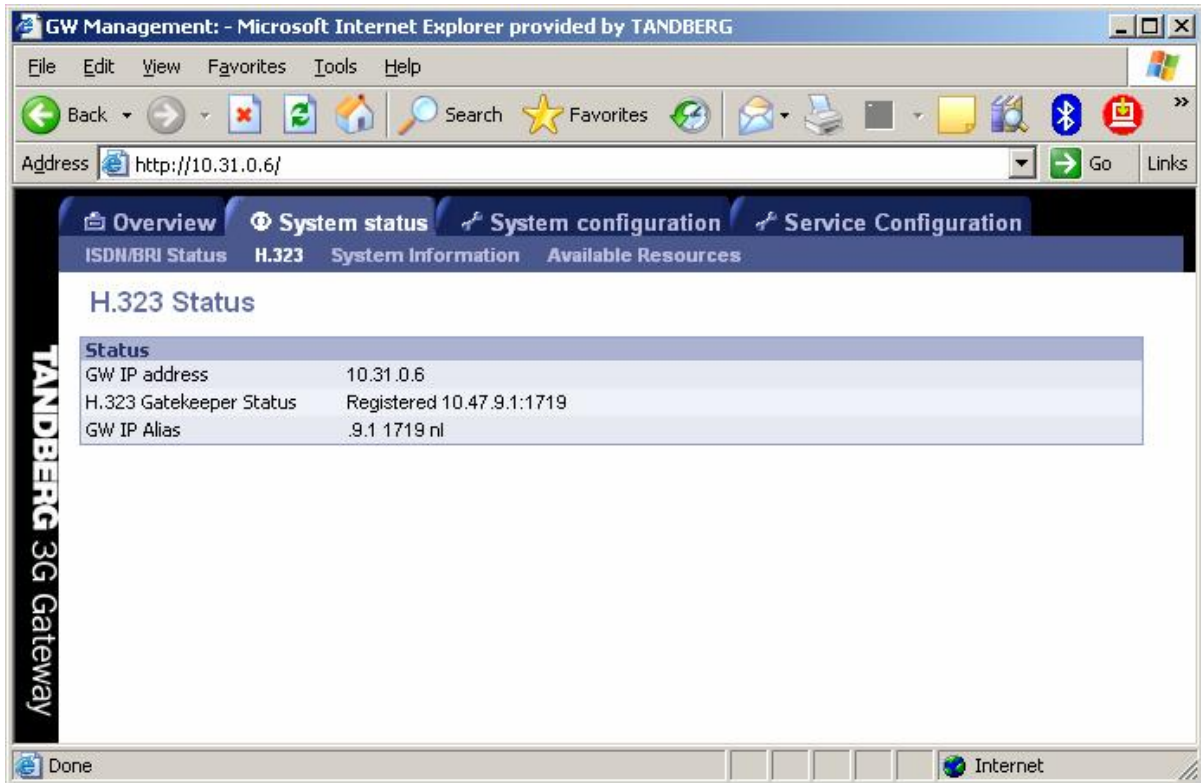

Note that it is not possible to use this IP address to place calls through the Gateway.

GW IP Address

Shows the IP address of the gateway.

H.323 Gatekeeper Status

Shows status and IP address of the Gatekeeper, the gateway is registered to. '**Inactive**' means the gateway is not registered to a gatekeeper. '**Registering**' means the gateway is having problems registering with selected gatekeeper.

GW IP Alias

This is the name the Gateway is registered with at the gatekeeper.

4.3 System Information

To view gateway information, open 'System Information' as shown in the figure below. This page provides information on installed software and hardware.

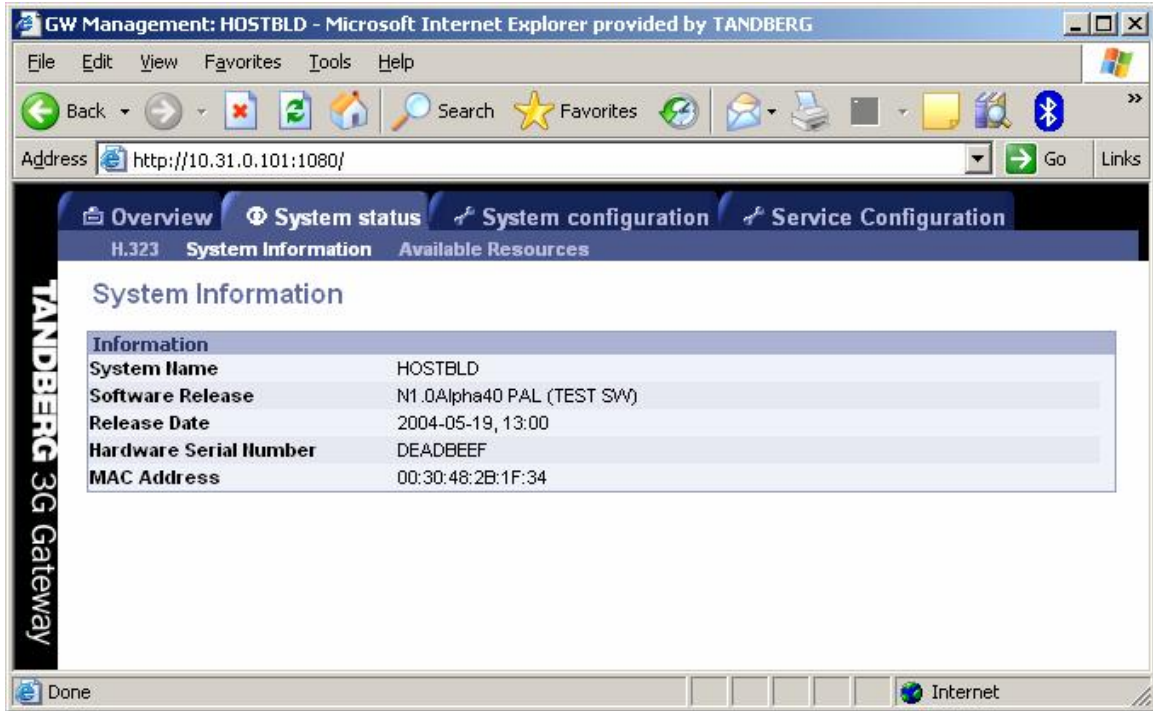

4.4 Available Resources

To view available resources on the gateway, open 'Available Resources' as shown in the figure below.

Resource	Available	Total
Video calls	30	30
ISDN channels	30	30
SystemLoad	100 %	100 %

The available resources shows the actual System Load, the amount of video calls and the amount of available ISDN channels. These figures depend on the usage of the system. Note that available SystemLoad 100% indicates no load on the gateway.

5 Configure the Gateway

To configure the gateway, open 'System Configuration' and 'Gateway Configuration'.

- [System Configuration](#)
- [IP Configuration](#)
- [H.323 Configuration](#)
- [SNMP Configuration](#)
- [Miscellaneous Configuration](#)
- [Software Upgrade](#)
- [Services Configuration](#)

5.1 System Configuration

5.1.1 PRI Configuration

To configure the PRI, select 'System Configuration - PRI' as shown in the figure below.

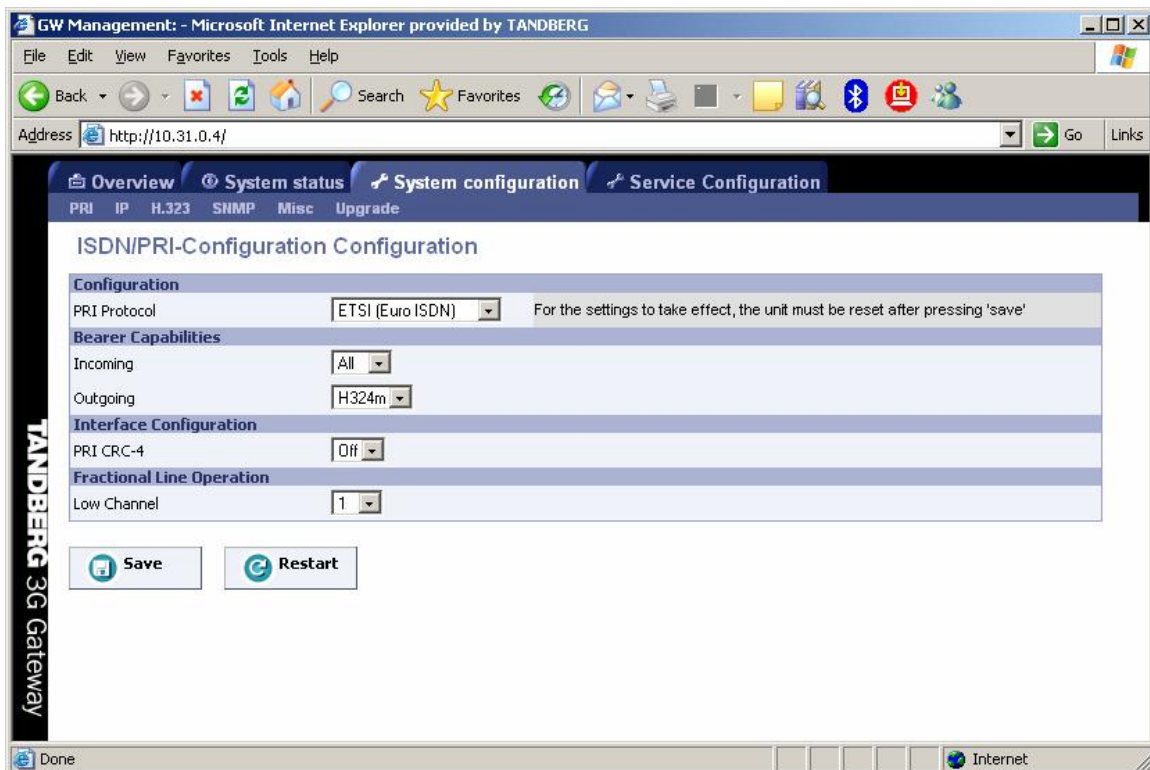

PRI Protocol

Select between the following PRI protocols:

- ETSI (Euro ISDN)
- National ISDN
- AT&T Custom

Save

When all settings are entered, please press the 'Save' - button to store the new settings.

Note changing from E1 to T1 configuration requires a restart of the unit.

Interface Configuration

This section configures the PRI or ISDN interface.

PRI CRC-4

Used for most E1-PRI configurations. If your network equipment does not support this feature, set PRI CRC-4 to Off.

Bearer capabilities

Within ISDN different bearer capabilities are used to signal the type of data (Voice, Data, H320, H324M), which is used by switches and other equipment to determine what to do with the data or the call (compressing voice data neglect etc).

- **Incoming:** sets the ISDN bearer capability of the incoming 3G calls.
 - **UDI:** In some situations the non correct UDI (Unrestricted Digital Information) bearer is used in stead of the right H324M capability. This setting makes it possible to accept incoming 3G calls with UDI bearer signalling.
 - **ALL:** Means that calls no matter which bearer are accepted. This makes it possible to even accept audio calls.
- **Outgoing:** sets the ISDN bearer capability for the outgoing 3G calls.
 - **H324M:** This ITU standardized capability is selected for outgoing calls by default.
 - **UDI:** In some situations the switch does not accept calls which use the correct H324M capability. This setting makes it possible to use the gateway in these situations via selecting UDI.

Low Channel

Indicates the lowest numbered E1/T1 B-channel the system is allowed to use for each PRI-line when selecting channels for outgoing calls.

5.1.2 BRI configuration

To configure the 4 BRI ports, select 'System Configuration - BRI' as shown in the figure below.

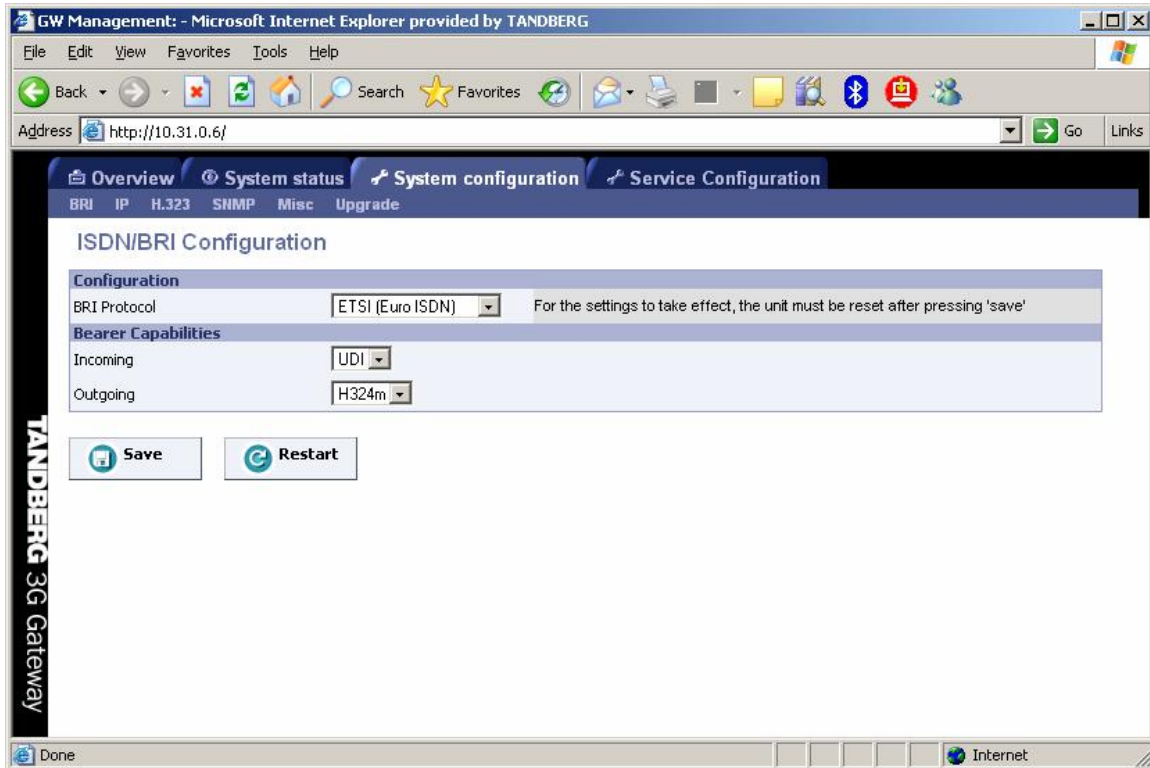

BRI Protocol

Select between the following BRI protocols:

- ETSI (Euro ISDN)
- National ISDN
- AT&T Custom

Bearer capabilities

Within ISDN different bearer capabilities are used to signal the type of data (Voice, Data, H320, H324M), which is used by switches and other equipment to determine what to do with the data or the call (compressing voice data, neglect etc).

- **Incoming:** sets the ISDN bearer capability of the incoming 3G calls.
 - **UDI:** In some situations the non correct UDI (Unrestricted Digital Information) bearer is used in stead of the right H324M capability. This setting makes it possible to accept incoming 3G calls with UDI bearer signalling.
 - **ALL:** Means that calls no matter which bearer are accepted. This makes it possible to even accept audio calls.
- **Outgoing:** sets the ISDN bearer capability for the outgoing 3G calls.
 - **H324M:** This ITU standardized capability is selected for outgoing calls by default.

- **UDI:** In some situations the switch does not accept calls which use the correct H324M capability. This setting makes it possible to use the gateway in these situations via selecting UDI.

Note that it is not possible to configure ISDN BRI lines for special functions like dial out only. The gateway will automatically select a free BRI line for H323 to 3G calls and possibly block a DiD or an IVR menu when the BRI lines have different numbers. It is therefore strongly recommended that all ISDN BRI lines have the same number range. Contact your ISDN or telecom supplier about numbering plans of ISDN lines.

5.2 IP Configuration

To configure the IP settings on the gateway, open 'System Configuration - IP' as shown in the figure below.

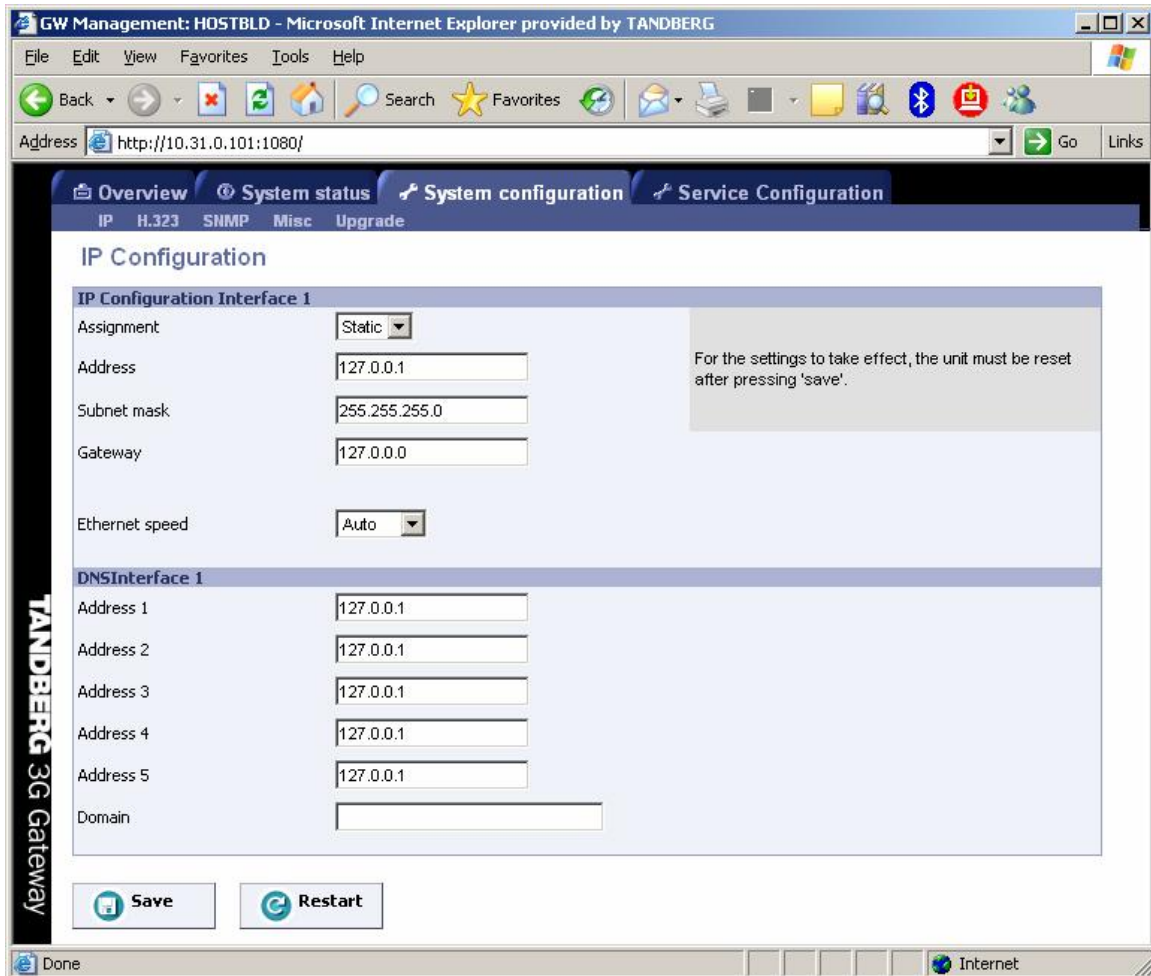

Configuration

IP Address Assignment

- DHCP:** Dynamic Host Configuration Protocol can be selected when a DHCP server is present. Static IP Address, Static IP Subnet Mask and Static IP Gateway are ignored because these parameters are assigned by the DHCP server.
- Static:** If Static assignment is used, the gateway's IP-address and IP-subnet mask must be specified in the IP-address field.

IP Ethernet Speed

Auto	The gateway will automatically detect the speed/duplex on the LAN.
10Half	The gateway will connect to the LAN using 10 Mbps/Half Duplex.
10Full	The gateway will connect to the LAN using 10 Mbps/Full Duplex.
100Half	The gateway will connect to the LAN using 100 Mbps/Half Duplex.
100Full	The gateway will connect to the LAN using 100 Mbps/Full Duplex.

Static IP Address

The Static IP Address defines the network address of the gateway. This address is only used in static mode. Your LAN administrator will provide you with the correct address for this field.

Static IP Subnet Mask

The Static IP Subnet Mask defines the type of network. Your LAN administrator will provide the correct value for this field.

Static IP Gateway

The Static IP Gateway defines the Gateway address. Your LAN administrator will provide the correct value for this field.

Save

When ready to store the new settings, press '**Save**'. These settings will take effect when the system is restarted.

Restart

This button will restart the gateway. Any changes made in IP Configuration and IP Service will then take effect.

5.3 H.323 Configuration

To dial out from IP to ISDN, through the gateway, requires the use of H.323 numbers (E.164 aliases). This means that the gateway must be registered to a Gatekeeper.

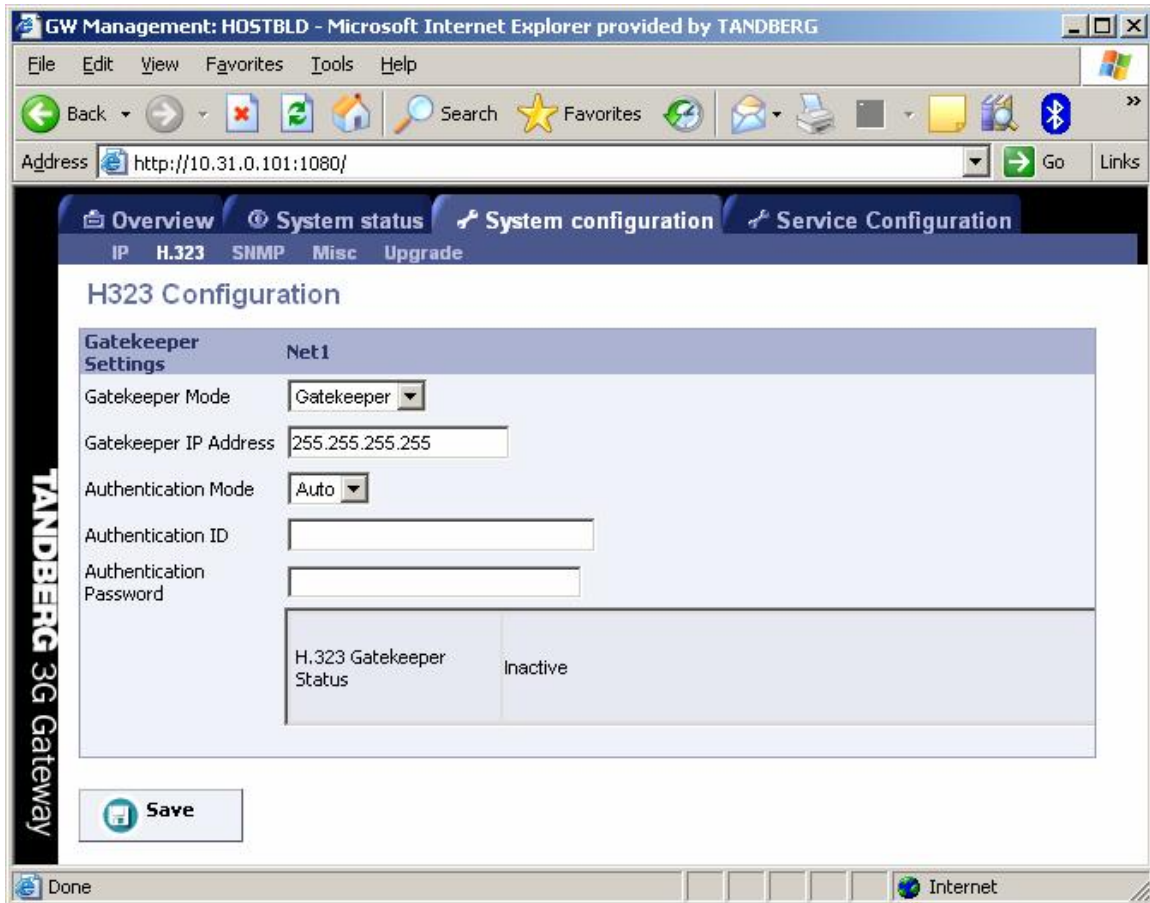

H.323 Gatekeeper Status shows the current status of the Gatekeeper registration.

Note that if the Gatekeeper is configured with an alternative Gatekeeper, the Status area might report a registration to the IP address of the alternative Gatekeeper.

Gatekeeper Settings

Gatekeeper Mode Enables the gateway to register to a Gatekeeper or without (direct mode). Selecting direct will gray out the gatekeeper IP address settings. When registered with a gatekeeper, the H.323 Gatekeeper Status shows Registered, Gatekeeper's IP address and what port used.

Selecting direct mode will result in no Gatekeeper registration; hence it is not possible to dial through the Gateway via alias names. The H.323 Gatekeeper Status window will show 'Inactive'.

Problems with registration will be shown in the Status area and as a Red alarm on the 'Overview' page.

Gatekeeper IP Address

Enter the Gatekeeper IP Address that the gateway should register to. Leaving empty will result in direct dialing without the use of aliases.

Authentication Mode

Off Register to the Gatekeeper without authentication.

Auto Register to the Gatekeeper with H.235 authentication using ID/Password given below.

Authentication ID, Password

Enter the ID and password required to perform H.235 authentication at the Gatekeeper.

To register to a Gatekeeper that requires authentication, an NTP server has to be configured.

Note in case password is empty the gateway will still use the Authentication ID for registering with the gatekeeper. In case Authentication ID is empty, the system name will be used for registration.

5.4 SNMP Configuration

SNMP (Simple Network Management Protocol) is used for monitoring and configuring different units in a network. The gateway's **SNMP Agent** responds to requests from **SNMP Managers** (a PC program etc.). **SNMP traps** are generated by the agent to inform the manager about important events.

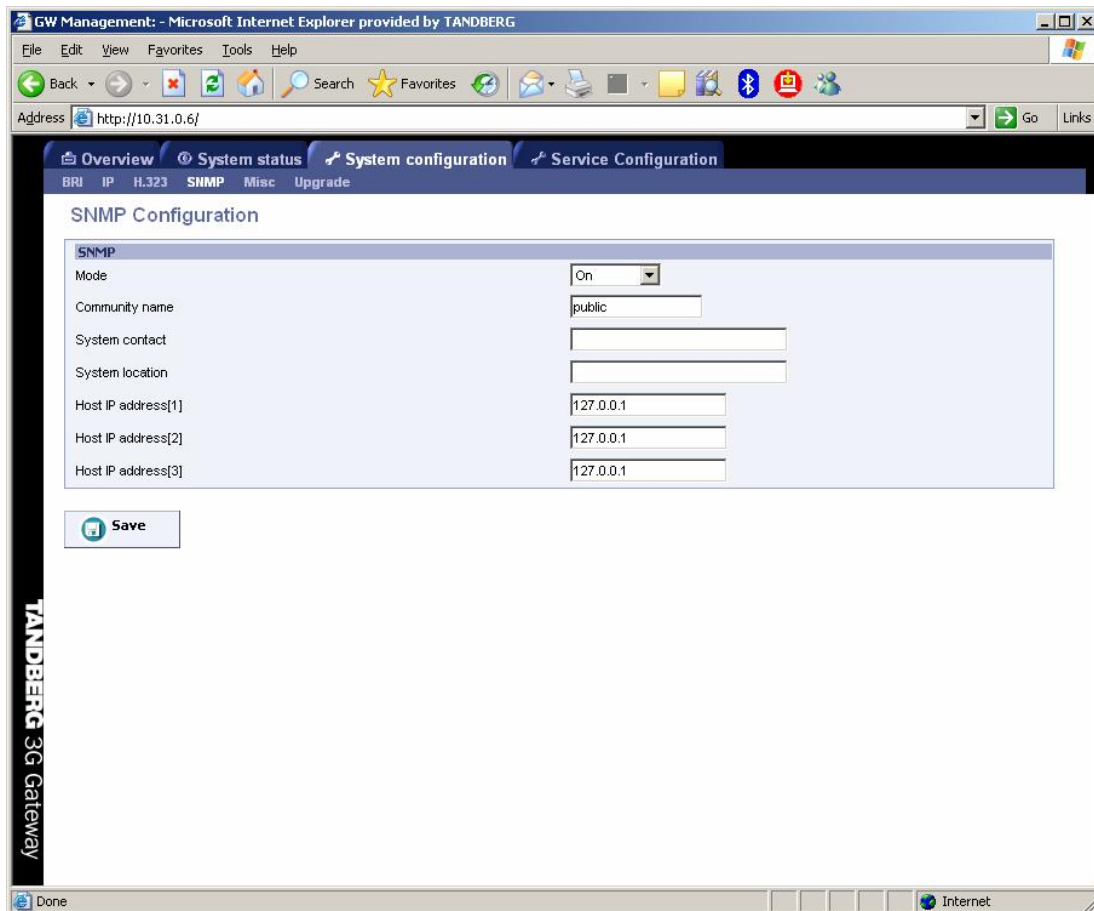

Note that the SNMP Community name is case sensitive.

Configuration

SNMP Mode

The SNMP operation modus can be set to:

- **On**, turnn SNMP on;
- **Off**, turn SNMP off;
- **ReadOnly**, Do not send SNMP information to the host.;
- **Traponly**, Only send SNMP information identified as TRAPS to the host.

SNMP Community Name

SNMP Community names are used to authenticate SNMP requests. SNMP requests must have this 'password' in order to receive a response from the SNMP agent in the gateway.

SNMP Trap Host (1, 2 and 3)

Identifies the IP-address of the SNMP manager. Up to three different SNMP Trap Hosts can be defined. Your LAN administrator should provide the correct values for these fields.

System Contact

Used to identify the system contact via SNMP tools such as HPOpenView or TANDBERG Management Suite.

Location

Used to identify system location via SNMP tools such as HPOpenView or TANDBERG Management Suite.

Save

Press '**Save**' to activate the new settings.
TANDBERG Gateway

5.5 Miscellaneous Configuration

To configure the miscellaneous settings on the gateway, open 'Misc' as shown in the figure below.

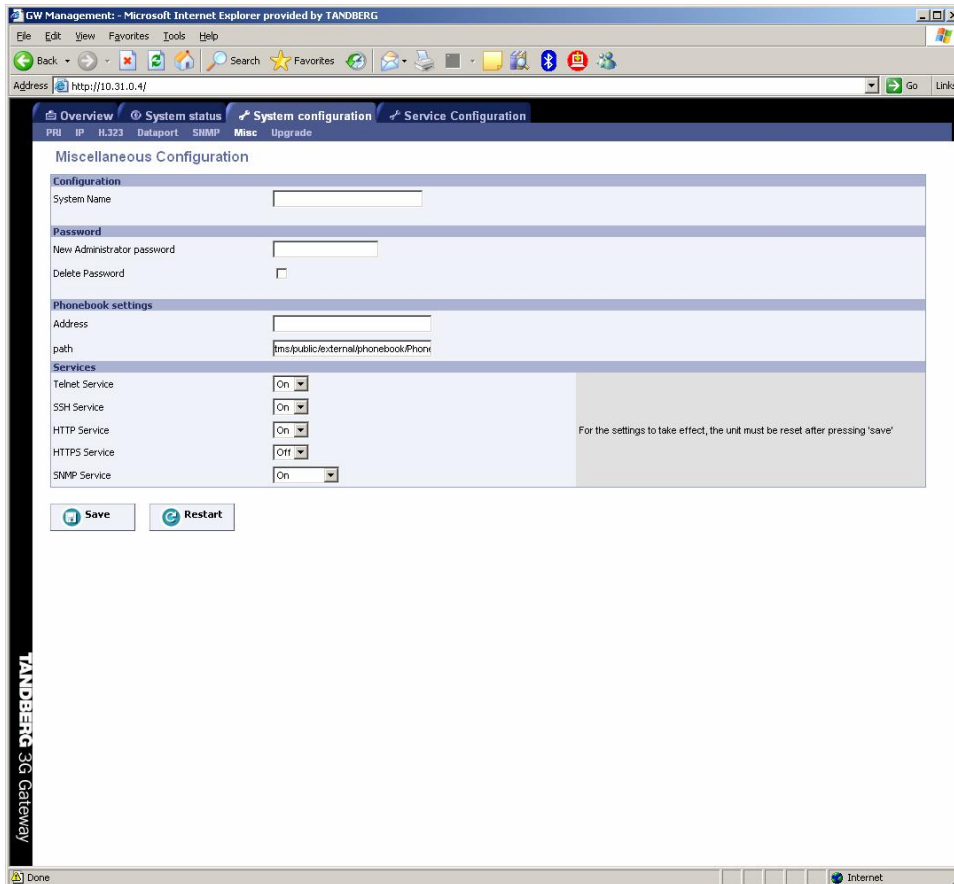

Configuration

To change the system name of the gateway, enter the new system name in the '**System Name**'.

Password

To change the system password of the gateway, enter the new password in the '**New Administrator Password**'. To delete the existing password, select '**Delete Password**'.

Phonebook settings

To enable a phonebook in the 3G Gateway it is required to configure a TMS server. Enter both the IP address and the phonebook path.

Services

The different IP services on the gateway - Telnet, Telnet Challenge, HTTP, HTTPS and SNMP can be independently disabled to prevent access to the system.

In addition, the SNMP Service Read Only/Traps Only will make it possible to read SNMP messages in addition to enable/disable SNMP.

Save

Press '**Save**' and then the '**Restart**'.

5.6 Software Upgrade

Software upgrade is where new software to the gateway can be installed from. It also shows current software version and the gateway's hardware serial number.

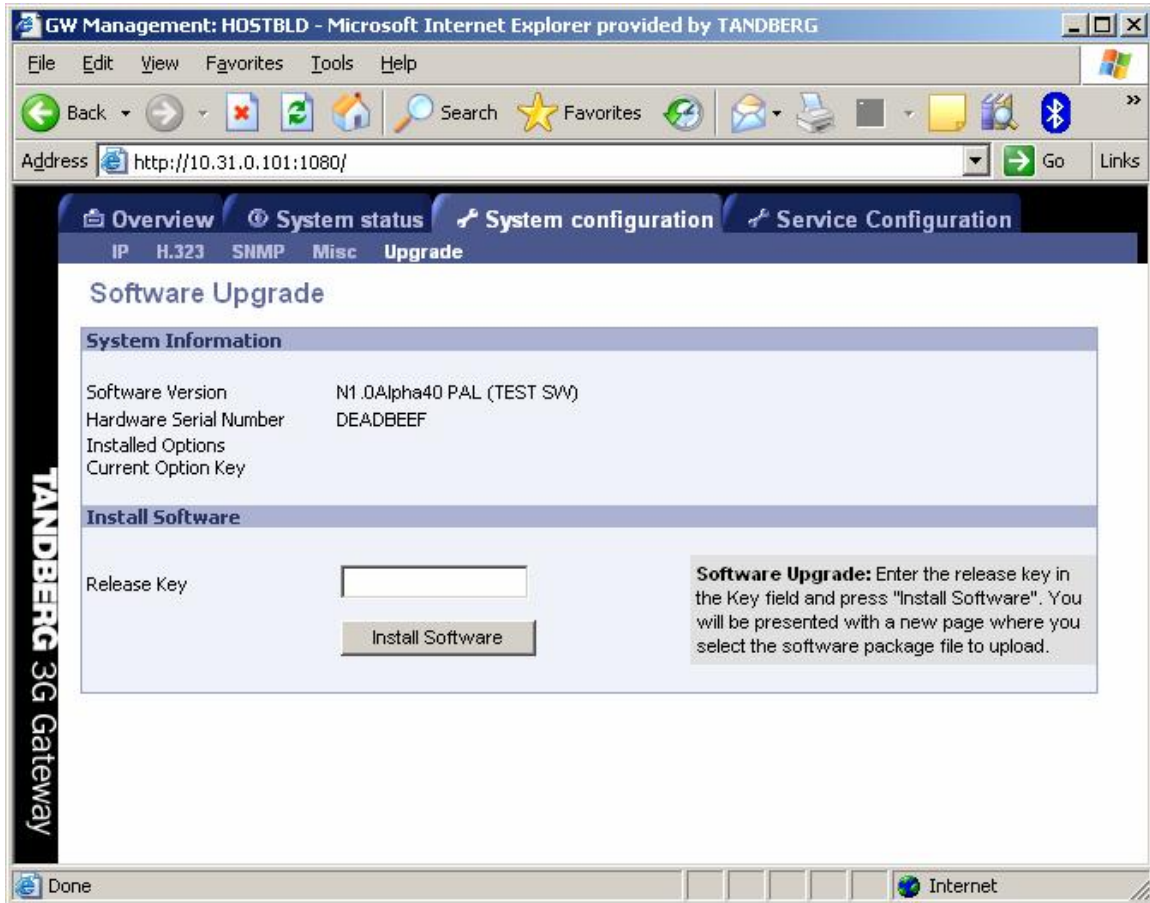

Note that to upgrade the Gateway, a valid Release key and Software file is required. Contact your TANDBERG representative for more details.

System Information

Software Version	Shows the currently installed Software version.
Hardware Serial Number	This unique identifier number for the gateway must be provided when ordering Software Upgrade.
Installed Options	Shows the currently installed Options.

Install Software

Release Key

Enter the release key in the Key field and press 'Install Software'. You will be presented with a new page where you select the software package file to upload.

5.7 Services Configuration

Dialing rules for both UMTS handsets and H323 endpoints are configured via the services menu. In the services menu the following services types are distinguished:

- “DiD” → Direct inwards dialling H.323 endpoint or 3G terminal
- “IVR” → Dialling H.323 endpoint/3G terminal via a selection menu
- “Phonebook” → Dialling H.323 endpoint/3G terminal from the 3G gateway phone book

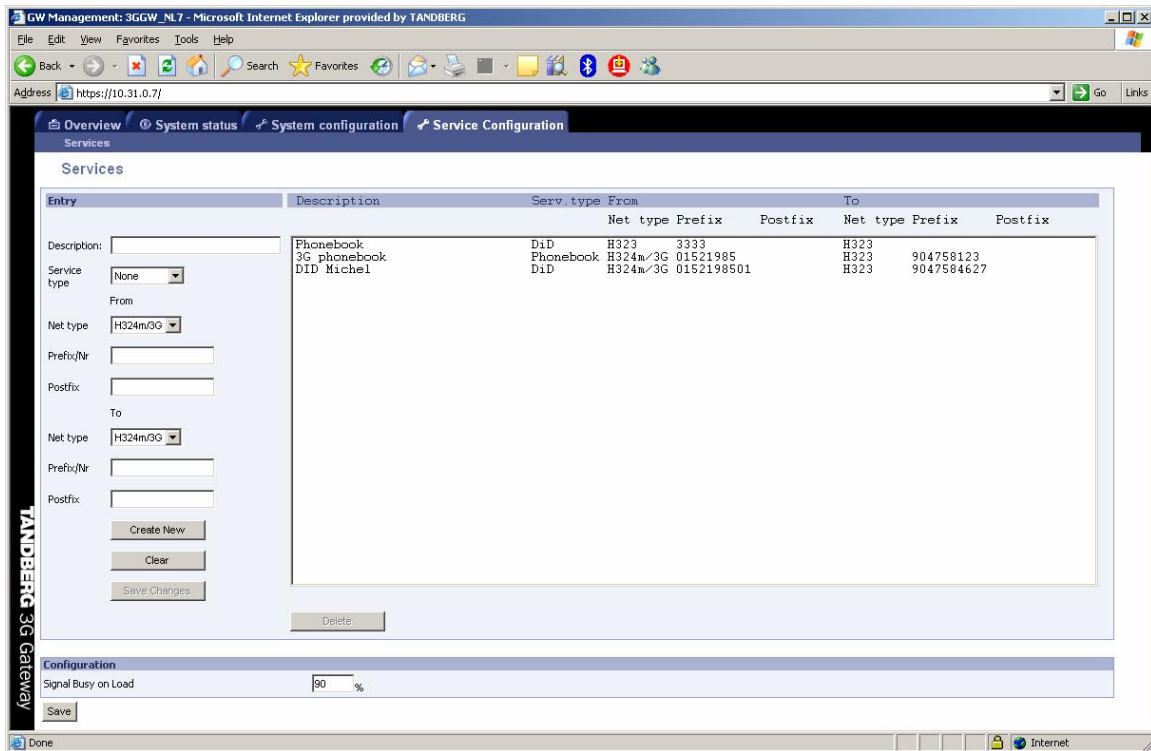

Figure 1: Proposed configuration webpage for the dialing rules.

Description

This is a friendly name for the service configured like for example 3G to H323.

Service type

Defines the type of service for a specific dial-in number (both H323 and 3G). Possible services are :

- “DiD”
- “IVR”
- “Phonebook”

Net type (from)

The net type indicates the dial in for this particular service configuration. Possible choices are:

- H323
- 3G / H324m

The configuration should be read from left to right as subsequent actions taken after each other: In Prefix/nr (remove)→ in Postfix(remove)→ Service type→ out Prefix/Nr (add)→ out Postfix (add). The in Prefix/Nr & Postfix set will be used for matching the incoming called number/address. The out Prefix/Nr & Postfix set will be used to construct the number/address that will be called (if applicable).

Prefix/nr (from)

In case a number matches this prefix it will be removed. Like for example:

Prefix/Nr: 6789
Dialed number: 67890000
Number used in rest of matching process is 0000

Postfix (from)

In case a number matches this postfix it will be removed. Like for example:

Postfix: 00
Dialed number: 67890000
Number used in rest of matching process is 678900

Net type (to)

The following settings are available which can be extended in future releases:

- H323
- 3G / H324m

Prefix/Nr (to)

This number will be put in front of a number dialed. Like for example:

Prefix/Nr: 1234
Dialed number: 4567
Number used in rest of matching process is 12344567

Postfix (to)

This number will be added after a number dialed. Like for example:

Postfix: 1234
Dialed number: 4567
Number used in rest of matching process is 45671234

Note that it is not possible to configure ISDN BRI lines for special functions like dial out only. The gateway will automatically select a free BRI line for H323 to 3G calls and possibly block a DiD or an IVR menu when the BRI lines have different numbers. It is therefore strongly recommended that all ISDN BRI lines have the same number range

5.7.1 IVR

The gateway contains a so called interactive video and voice response system which makes it possible to select destinations from a phonebook. It is also possible to submit a number of an IP endpoint when the extension is known. The figure below shows an example of the input screen.

The screenshot shows a text input field with the prompt "Please enter extension number". Below the input field are two rows of navigation options: "* to backspace" and "# to dial".

The numbers typed will appear after +/- ½ a second on the screen. Pressing the # key after submitting the number will start the gateway connecting with the endpoint with the submitted number.

The screenshot shows a list of names under the heading "all". The names are: Alfredo.truji, Alisandair.munro, Allan.bjørnstad, and Berit.blom. Below the list are two rows of navigation options: "+ to backspace" and "# to dial".

The phonebook available via the IVR and is an interactive listing of the TMS address book that is added to the gateway.

Make sure you do not add more than one phonebook to the 3G Gateway via TMS. It is possible to add several phone books to the 3G Gateway via TMS. However adding more than one phonebook to the 3G gateway will result in a **non** working phonebook service.

5.7.2 examples

Below there are two examples of service configurations.

Example 1: Number plan mapping

Service type DiD
Net type (from): H324m/3G
From Prefix/Nr: 6789
From Postfix:
Net type (to): H323
To Prefix/Nr: 5
To Postfix:

When dialing the number 67890000 there will be a match with “0000” as the significant number. The H.323 number to call is: 50000 (construction: prefix + significant numbers + postfix). When dialing number 67894321 this will match with “4321” as the significant number. The H.323 number to call is: 54321 (construction: prefix + significant numbers + postfix)

Example 2: Hotline

Service type DiD
Net type (from): H324m/3G
From Prefix/Nr: 67890000
From Postfix:
Net type (to): H323
To Prefix/Nr: 51234
To Postfix:

When dialing number 67890000 this will match with no significant number. The H.323 number to call is: 51234 (construction: prefix + significant numbers + postfix). When dialing number 67894321 this will not match.

6 Appendices

- [Appendix 1: Declaration of Conformity](#)
- [Appendix 2: Using the front panel LCD keys](#)

Appendix 1: Declaration of Conformity

Contact your TANDBERG representative for a Declaration of Conformity.

Appendix 2: using the front panel LCD keys

Every button on the front panel has multiple functions due to the limited amount of keys. In this appendix it is explained what the different functions are at different levels.

State 0: Display Status info

Any Key: State 1

State 1: menu navigation, Display current menu item

- **Up/Down**: navigate between different sub-menu's
- **ESC** Up in the menu structure, State 1; from lowest level to State 0
- **ENTER** for menu items: deeper into the menu structure, State 1
- **ENTER** for data items: State 2
- **ENTER** for selectable data items: State 7
- **ENTER** for command items (reboot..): State 6

State 2: Show Data Element (1e line Data Element description, 2e line Data Element value)

- **Up/Down**: Scrolling in the content if wider then 1 display width, State 2
- **ESC**: State 1
- **ENTER** for textual data items: State 3
- **ENTER** for selectable data items: State 7

State 3: Navigate within textual data element

- **Up/Down**: Cursor (non blinking) place on correct location in the data element, if necessary scroll. Positions with an alphabet of only 1 character (e.g. the full stop "." in an IP address) is skipped), State 3
- **Enter**: State 4
- **ESC**: With changes in the data: State 5 Confirm
- **ESC**: Without changes in the data: State 2

State 4: Edit textual data element, Cursor blinking on the character position to be changed

- **Up/Down**: Change character cyclic within the alphabet for that position, State 4
- **ENTER**: Next position (as State 3 [UP]), State 4
- **ESC**: State 3

State 5: "Confirm" Menu with 2 Items that can be scrolled using UP/DOWN (like State 1), "Yes"/"No", "No" is de default.

- **Up/Down**: browse Yes/No
- **ENTER**: in No state: State 3
- **ENTER**: in Yes state, store, State 2
- **ESC**: Cancel the edit, State 2

State 6: "Confirm" Menu Items like State 1 with Yes/No, No is the default

- **Up/Down**: Scroll through Yes/No
- **ENTER**: Confirm choice, State 1
- **ESC**: State 1

State 7: Choose Configuration option.

- **Up/Down** previous/next, State 1
- **ESC** Cancel Edit, to State 2
- **ENTER** Confirm Edit, to State 2