

## OWNER'S MANUAL

# DieHard®

**BATTERY CHARGER**  
**60/20/2 Amp**  
**Fully Automatic**

**275/125 AMP**  
**ENGINE STARTER**  
**With Battery Tester**

**Model No.**  
**200.71232**



**CAUTION:**  
Read all Safety Rules and Operating Instructions,  
and follow them with each use of this product.

---

Sears, Roebuck and Co., Hoffman Estates, IL 60179 U.S.A.

---

00-99-000314/0103



# Table Of Contents

<b>Warranty</b> .....	<b>1</b>	<b>Using Your Battery Charger</b> .....	<b>7</b>
<b>Important Safety Instructions</b> .....	<b>2</b>	Setting the controls .....	<b>7</b>
<b>Parts</b> .....	<b>3</b>	Charging your battery .....	<b>9</b>
<b>Before Using Your Battery Charger</b> .....	<b>4</b>	Calculating charge times .....	<b>12</b>
Assembling your charger .....	<b>4</b>	Using the engine start feature .....	<b>13</b>
Plugging it in .....	<b>5</b>	Maintenance and care .....	<b>13</b>
Using an extension cord .....	<b>6</b>	<b>Troubleshooting</b> .....	<b>14</b>
Preparing your battery to be charged .....	<b>6</b>		

## **Please read this Manual before using your Battery Charger**

The DieHard model 71232 Automatic Battery Charger/Engine Starter, offers a wide range of features to accommodate the needs for home or light commercial use. This manual will show you how to use your charger safely and effectively. Please read and follow these instructions and precautions carefully.

For information about troubleshooting, call toll-free from anywhere in the U.S.A. 7 am to 4:30 pm CT Monday through Friday.

**1-800-SEARS-64 (1-800-732-7764).**

For repair parts or the location of a Sears Parts and Repair Center call:

**1-800-4-MY-HOME® (1-800-469-4663).**

## **Warranty**

### **FULL THREE-YEAR WARRANTY**

If, within three years from the date of purchase this battery charger fails due to a defect in material or workmanship, RETURN IT TO THE NEAREST SEARS STORE IN THE UNITED STATES, and Sears will repair or replace it, free of charge.

This warranty gives you specific legal rights, and you may also have other rights which vary from state to state.

Sears, Roebuck and Co., Dept 817WA,  
Hoffman Estates, IL 60179

# Important Safety Instructions

– SAVE THESE INSTRUCTIONS –



## WARNING

To reduce the risk of explosion, explosive gases, or injury while using your battery charger, follow the precautions listed below:

- Read **all** instructions and cautions printed on the battery charger, battery, and vehicle or equipment using battery.
- Use charger only on **lead-acid** type rechargeable batteries, such as those used in cars, trucks, tractors, airplanes, vans, RV's, trolling motors, etc. This charger is not intended to supply power to a low voltage electrical system other than in an automotive application.
- **Use only** attachments recommended or sold by manufacturer. The use of attachments not recommended by the manufacturer may result in fire, electric shock, or injury.
- **Do not** disassemble charger. Take it to a qualified service professional if service or repair is required. Incorrect assembly may result in fire or electrical shock.
- To reduce risk of electrical shock, **unplug** the charger from the outlet before attempting any maintenance or cleaning.
- **Always** charge battery in a well ventilated area.

## Help us help you

### Remember:

- **Place** charger as far away from battery being charged as the charger cables will permit.
- **Do not** expose charger to rain or snow.
- **Never** charge a frozen battery. If battery fluid (electrolyte) becomes frozen, bring battery into a warm area to thaw before you begin charging.
- **Never** allow battery acid to drip on charger when reading specific gravity or filling battery.
- **Never** set a battery on top of the charger.
- **Never** place charger directly above battery being charged. The gases from the battery will corrode and damage the charger.
- **Never** use charger for charging dry-cell batteries that are commonly used with home appliances. These batteries may burst and cause personal injury.
- **Never** touch the battery clamps together when the charger is energized.
- **Never** operate charger if it has received a hard blow, been dropped, or otherwise damaged. Take it to a qualified professional for inspection and repair.
- **Be sure** to position the charger power cord to prevent it from being stepped on, tripped over, or damaged.
- **Never** pull out the plug by the cord when unplugging the charger. Pulling on the cord may cause damage to the cord or the plug.
- **Do not** operate the charger if it has a damaged power cord or plug. Have the cord replaced.

## Personal Safety Precautions

For your own personal safety, please follow the following precautions:

- **Wear complete eye and clothing protection** when working with lead-acid batteries.
- **Be sure** that someone is within range of your voice to come to your aid if needed while you work with or are near a lead-acid battery.
- **Have plenty of fresh water and soap** nearby for use in case battery acid contacts your eyes, skin, or clothing. If this happens, wash immediately with soap and water. Then get medical attention.
- **Avoid touching your eyes** while working with a battery. Acid particles (corrosion) may get into your eyes. If this occurs, flush eyes immediately with running cold water for at least 10 minutes. Then immediately get medical attention.
- **Remove all personal metal items** from your body, such as rings, bracelets, necklaces, and watches while working with a lead-acid battery. A battery can produce a short circuit current high enough to weld a ring (or the like) to metal, causing a severe burn.
- **Take care** not to drop any metal tool or metal object onto the battery. This may spark or short circuit the battery or another electrical device that may cause an explosion.
- **Always** operate your battery charger in an open, well ventilated area.
- **Never** smoke or allow a spark or flame in the vicinity of the battery or engine. Batteries generate explosive gases.
- **Neutralize** any acid spills thoroughly with baking soda before attempting to clean up.
- **WARNING:** Handling the cord on this product or cords associated with accessories sold with this product, will expose you to lead, a chemical known to the State of California to cause cancer and birth defects or other reproductive harm. **Wash hands after handling.**

# Parts

This section shows an illustration of your battery charger. Use it to become familiar with where all the parts are located, and what they look like.

Replacement Parts List DieHard 71232		
Item	Description	Part Number
1.	Plastic Top	3799001210
2.	Hub Cap	5200000008
3.	Wheel	0099000120
4.	Axle	0099000060
5.	Power Cord	90026133
6.	Negative (Blk) Cable w/Clamps	3899000694
7.	Positive (Pos) Cable w/Clamps	3899000696
8.	Circuit Breaker	3999000066
9.	Transformer	93026470
10.	SCR Assembly	2299000755
11.	Harness (Not Shown)	3899000806
12.	Fan Motor	0099000063
13.	Rocker Switch DPDT	0499000053
14.	Rocker Switch SPST	0499000050
15.	Touch Pad Decal	0899001726
16.	Mounting Foot	1199005112
17.	Handle	3599000262
18.	Owner's Manual	0099000314
19.	Axle Mtg. Brackets	1199004366
20.	Control Board (Under Hood)	2299000937

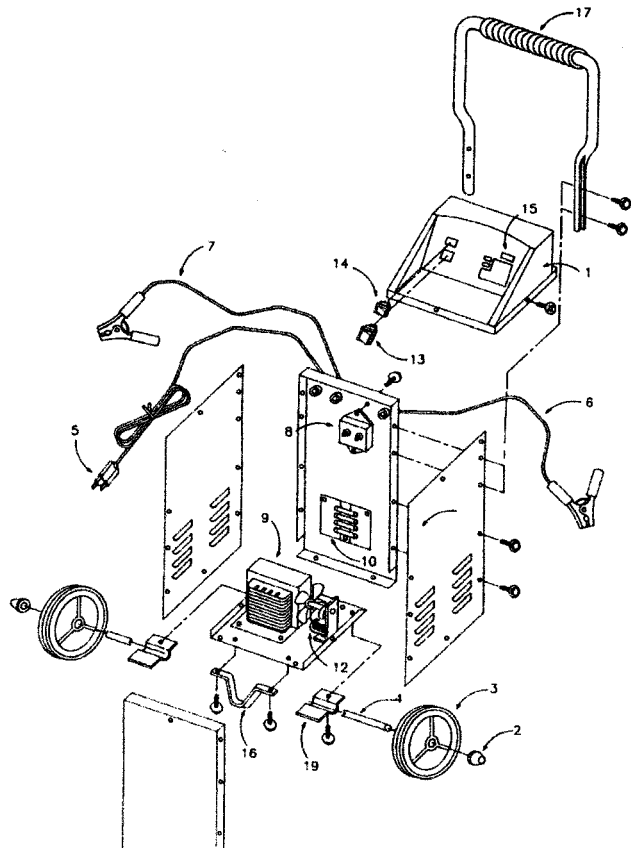

# Wiring Diagram

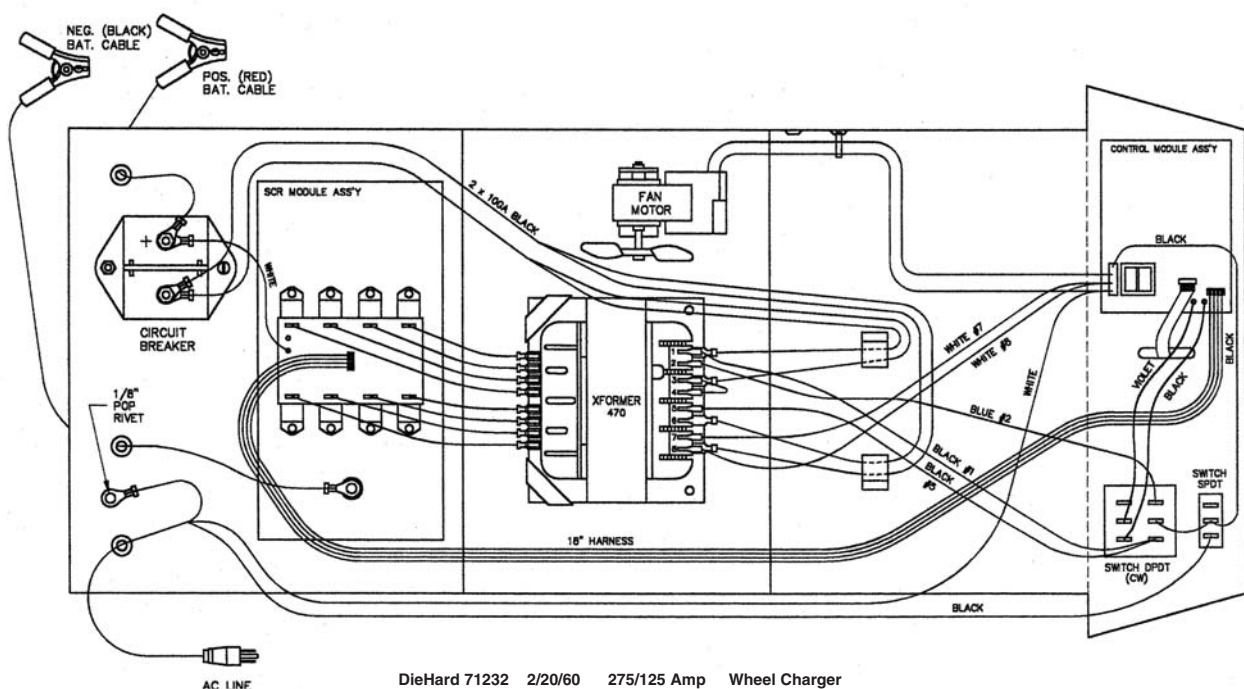

# Before Using Your Battery Charger

It is important to prepare your charger for use. This section will tell you how to assemble the charger, ground and connect the power cord, and prepare to charge a battery.

## Assembling your charger

It is important to fully assemble your charger before use. Follow these instructions for easy assembly.

PARTS:	TOOLS NEEDED:
Two 10-32 thread cutting screws	3/8" wrench (for mounting foot)
Two 1/4-20 thread cutting screws	5/16" wrench (for wheels)
Two wheels	Hammer
One axle	Phillips screwdriver
Two axle caps	
Two axle brackets	
One handle	
One mounting foot	

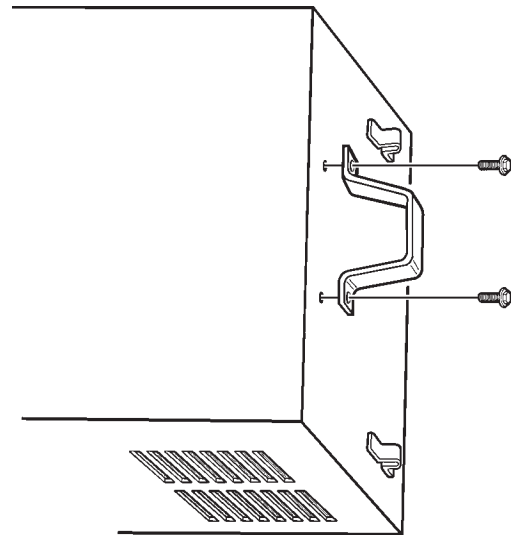

### To attach the axle assembly:

1. Remove charger from packing materials and place upside down on a flat surface. Attach mounting foot and secure with the two 1/4-20 thread cutting screws.
2. Hold axle upright on floor or work surface. Then, using a hammer, tap one of the plastic hubs onto the top end of the axle. Be sure to tap the hub on straight. Slide both wheels onto the axle with the hubs facing inward.

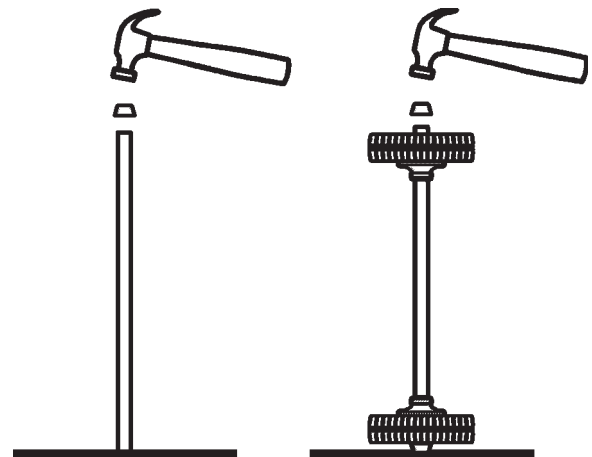

continued on next page

3. Tap the other axle cap onto the opposite end of the axle and place the axle assembly onto the bottom of the charger. Place one end of the bracket into slot, then place the axle assembly under each bracket. Fasten the other side of the brackets using the two 10-32 screws provided.

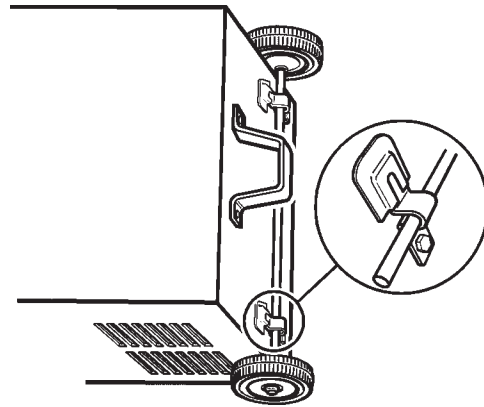

### To attach the handle:

Turn the charger right side up onto its foot and wheels. Remove the two top screws from each side of the charger and align with the screw holes on the handle. Attach the handle using the same screws.

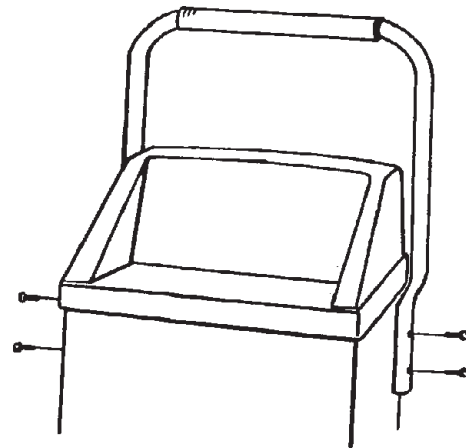

---

## Plugging it in

### **WARNING**

#### **Electrical Shock Hazard**

Be sure that power cord fits properly into outlet. If not, have a qualified technician install a proper outlet. Never alter the AC cord or plug provided. Improper connection can result in electrical shock.

**Your charger should be grounded to reduce the risk of electrical shock.**

Your charger is equipped with an electrical cord that has an equipment grounding conductor and a grounding plug designed to be used on a 120 volt circuit. The plug must be plugged into an outlet that has been properly installed and grounded in accordance with all local codes and ordinances.

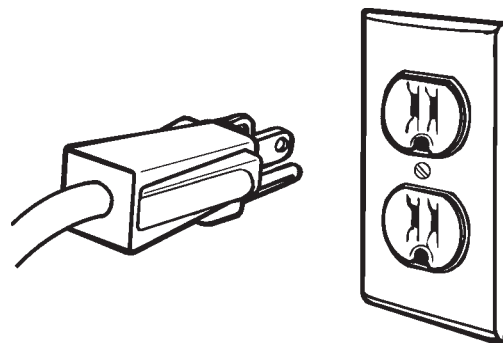

A **TEMPORARY** adapter may be used to connect the charger to a two-pole outlet if a properly grounded outlet is not available. Use the adapter **ONLY** until a properly grounded outlet can be installed by a qualified electrician.



**WARNING: Improper adapter connection can result in electrical shock.**

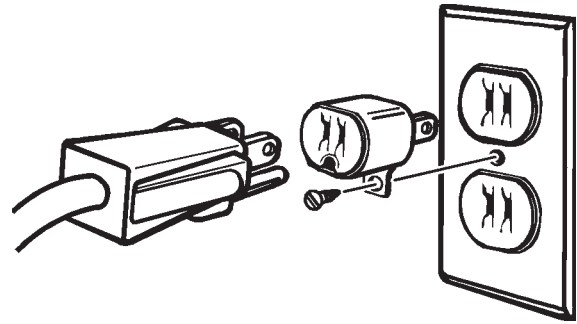

Before using an adapter as illustrated, be certain that the center screw of the outlet plate is grounded. The green colored grounding clip of the adapter must be attached by a metal screw to a properly grounded outlet. If unsure whether outlet is properly grounded, contact a professional electrician. If necessary, replace the original outlet cover screw with a longer one that will secure the grounding clip to the outlet cover and make a ground connection to the grounded outlet.

## Using an extension cord

The use of an extension cord is not recommended. If you must use an extension cord, please make sure that you follow these guidelines:

- Make sure the pins on the plug of the extension cord are the same number, size, and shape as those of the plug on the charger.
- Use only 3-conductor (grounded) extension cord when necessary.
- Check that the extension cord is properly wired and in good electrical condition.
- Use the recommended minimum AWG (American Wire Gauge) to be sure that wire size is large enough for the rating of the charger.

MINIMUM RECOMMENDED EXTENSION CORD				
Length of Cord, in Feet	25	50	100	150
AWG* Size of Cord	16	12	10	8

\*AWG=American Wire Gauge

## Preparing your battery to be charged

It is important that you read and follow these guidelines while you are preparing to charge your battery.

- Make sure that you have a 12 volt or 6 volt lead-acid battery. Set the volt/amp selector switch to match the voltage rating of the battery to be charged.
- Clean the battery terminals. Be careful to keep corrosion from getting in or around your eyes.
- If you have a battery with removable cell caps, if required, add distilled water to each cell until the battery acid reaches the level recommended by the manufacturer. This will help purge excessive gases from the cells. Be careful not to overfill. If you have a sealed battery without cell caps, no action is necessary. Continue to the next step listed below.
- Take time to read all battery manufacturer's specific precautions, such as removing or not removing cell caps while charging, and recommended rates of charge.
- Wear safety glasses. See additional "Personal Safety Precautions" on page 2.
- Be sure that the area around the battery is well ventilated while it is being charged. If ventilation is poor, gas can be manually blown away by using a piece of cardboard or other non-metallic material as a fan.
- If it is necessary to remove the battery from the vehicle to charge it, always remove the grounded terminal from the battery first. A spark may be caused if all accessories in the vehicle are not completely turned off.

**NOTE:** A marine battery installed in a boat must be removed and charged on shore.



# Using Your Battery Charger

For best results from your battery charger, learn to use it properly. This section tells how to set the controls, charge a battery in or out of the vehicle, use the ENGINE START feature and test the battery.

## Setting the controls

All the controls for your charger are located on the front of the unit. Follow these instructions to obtain the accurate charge level for your battery.

### POWER ON/OFF SWITCH

Make sure your charger is OFF when connecting or disconnecting your charger from the vehicle and power source. Turn your charger ON only when it is connected to the vehicle and power source.

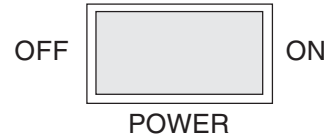

### BATTERY VOLTAGE SELECT

When charging, testing or starting 12 volt systems, select 12 VOLT. Select 6 VOLT when charging, testing or starting 6 volt systems.

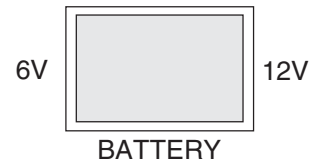

### TOUCH-PAD CONTROLS

With your charger connected to the vehicle and power source, the battery voltage (6 or 12 volt) selected, and the power turned ON, select either AUTOMATIC or MANUAL charge and the rate at which you want to charge your battery (2, 20, or 60 amp).

- **AUTO (Automatic):** When first turned ON, the charger will be in the Manual mode. Touch the AUTO pad and either the 2, 20, or 60 AMP Charge Rate Selector pad. Charging will start after a short delay. It will stop when the battery is fully charged. While charging, the METER will show battery voltage. Touch the VOLTS/AMPS pad to see the amount of amps being drawn by the battery.
- **MANUAL:** When first turned on, the charger will be in the Manual mode - there will be no need to select MANUAL. Select a charge rate and time. The charger will start charging after a short delay. **It will stop charging only when the selected time or maximum time is up.** For this reason, it is IMPORTANT to check the charger frequently to avoid overcharging the battery. While charging, the METER will show battery voltage. To see how much of the selected charge time is remaining, touch the TIME pad. The METER will show the time and, after a short delay, return to showing voltage. To see the amount of amps being drawn by the battery, touch the VOLTS/AMPS pad.

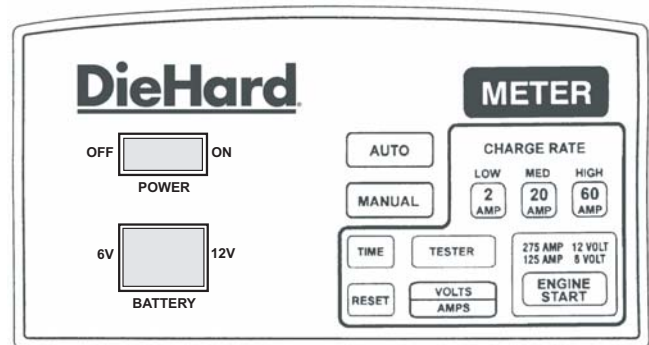

- **TIME:** To select a charging time, you must be in the MANUAL mode and have selected a charge rate. Touch the TIME pad until the desired time shows on the meter. The following chart shows the amount of time available for each charge rate and the amount of time, in hours, added for each touch of the TIME pad.

RATE	2 Amps	20 Amps	60 Amps
Maximum Time	18 Hours	10 Hours	5 Hours
Increment Settings	1 Hour	1 Hour	1/2 Hour

If you do not set a time, the charger will run for the maximum time. After selecting the charge rate and proper time, the charger will start charging after a short delay. To see how much time remains during the charging process, touch the TIME pad.

- **RESET:** To stop charging or to change settings once charging has begun, touch the RESET pad. Then proceed as if you've just turned on the charger.
- **VOLT/AMP:** When the charger is turned on the METER will display battery voltage. Touch the VOLTS/AMPS pad to display the charge rate in amps.
- **TESTER:** To check the battery's state-of-charge during charging, touch the RESET pad and then the TESTER pad. The METER will show the voltage of the battery. Wait about 5 minutes before taking a reading. To continue charging, proceed as if you've just turned the charger ON.
- **ENGINE START:** To use the starter feature to help crank the engine of your vehicle, touch RESET, MANUAL, and ENGINE START - in that order. Wait for the display to show RDY. The ENGINE START feature will deliver 275 amps to help crank a 12-volt system or 125 amps to help crank a 6-volt system. Crank the engine for **no more than 5 seconds**. If it does not start, **wait four minutes** before cranking again. During extremely cold weather, or if the battery is severely exhausted, charge the battery for about 5 minutes in the 60 AMP setting before cranking the engine.

**CAUTION: DO NOT** try to crank an engine without a battery installed. You may damage the vehicle's electrical system.

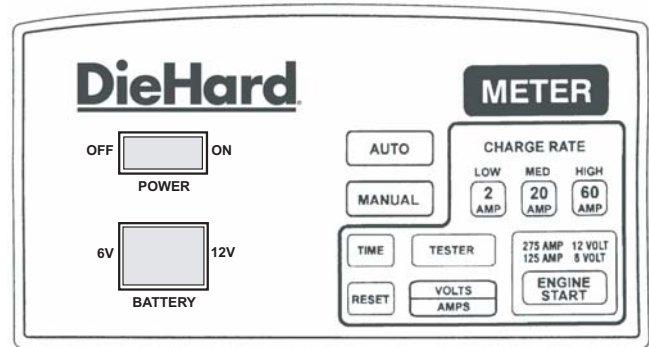
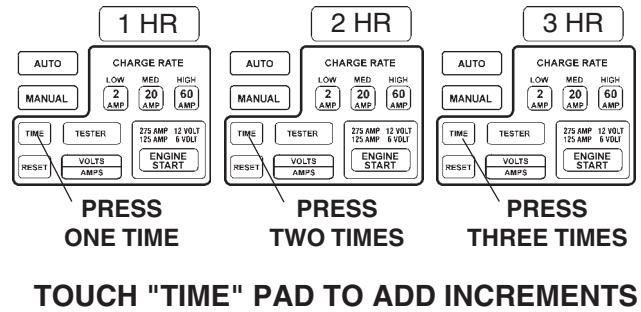

- **METER:** Besides showing amps, volts, and time, the meter displays information:

—A—	Charge Rate in amps
—V—	Voltage
MAN	Charger is in Manual mode
AUTO	Charger is in Automatic mode
RDY	Charger is ready for cranking (Engine Start)
WAIT	Wait until the charger is ready before cranking again
FULL	Battery is charged (Automatic mode)
OFF	Time has expired (Manual or Timer mode)
HR	Hour(s)
CHK BATT	There is a problem with the battery or connections
OL	Too high a charging rate; lower rate to continue

## Charging Your Battery

### Charging your battery in the vehicle:

1. Arrange the power cord and charging leads carefully in order to avoid damage that could be caused by the hood, door, or moving engine parts.
2. Keep clear of the fan blades, belts, pulleys, and other parts that can cause injury.
3. Check the polarity of the battery posts using the identification marks on the battery case: POSITIVE (POS, P, +) and NEGATIVE (NEG, N, -).
4. Identify which battery post is grounded or connected to the chassis. **THE NEGATIVE POST IS NORMALLY THE ONE THAT IS GROUNDED.**
5. **To charge a negative grounded post system:** Connect the red (POSITIVE) charger clamp to the ungrounded POSITIVE (POS, P, +) post of the battery. Next, connect the black (NEGATIVE) clamp to an unpainted, heavy metal part of the chassis or engine block, away from the battery. Do not connect clamp to carburetor, fuel lines, or sheet metal parts.

**To charge a positive grounded post system:** Connect the black (NEGATIVE) charger clamp to the ungrounded NEGATIVE (NEG, N, -) post of the battery. Then connect the red (POSITIVE) clamp to an unpainted, heavy metal part of the chassis or engine block, away from the battery. Do not connect clamp to carburetor, fuel lines or sheet metal parts.

**IMPORTANT:** Wear safety glasses and face away from the battery while making connections.

6. Twist or rock clamps back and forth to make a solid connection. This will help make better contact and help keep them from slipping off and causing sparks.
7. Make sure the POWER switch is set to the OFF position. Next plug the power cord into a grounded AC outlet.

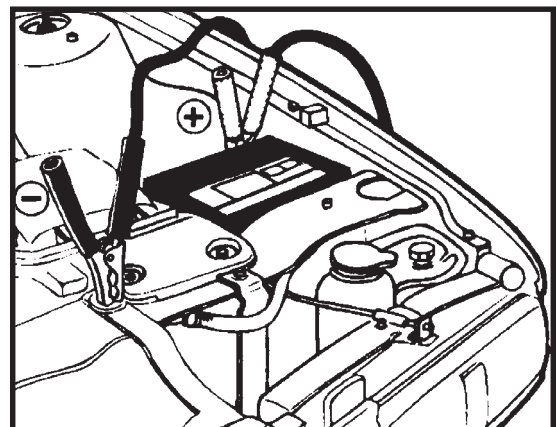

**NEGATIVE GROUNDED SYSTEM**

8. For automatic charging, touch AUTO then a charge-rate pad 2, 20, or 60 Amps. The charging will stop when the battery is fully charged.
  9. For manual charging, touch a charge rate pad then select a charge time up to 18 hours. If more than 135 minutes of charging time is needed, reset the time when the original time runs out. Refer to the Time Chart in the "Setting the Controls" on page 8 of "Using your Battery Charger."
  10. In the MANUAL mode, at the 60-Amp charging rate, the METER will show a charge rate of 25 to 30 amps or less when the battery is at or near full charge. At the 20-Amp charging rate, the METER will show a charge rate of 8 to 10 amps or less when the battery is at or near full charge. At the 2-Amp charging rate, the METER will show a charge rate of .75 to 1 amp when the battery is at or near full charge.
  11. TO AVOID OVERCHARGING in the Manual mode, monitor the METER frequently.
  12. When the battery is fully charged, turn the POWER switch to the OFF position and unplug the charger power cord.
  13. Standing away from the battery, remove the charger clamps in this order: (1) from the chassis connection and, (2) from the battery post or terminal.
  14. Clean and store the battery charger in a dry location.
6. Make sure the POWER switch is set to the OFF position. Next plug the power cord into a grounded AC outlet.
  7. For automatic charging, touch AUTO then a charge-rate pad. The charger will quit when the battery is fully charged.
  8. For manual charging touch a charge rate pad then select a charge time, from up to 18 hours. If more than 135 minutes of charging time is needed, reset the time when the original time runs out. Refer to the time chart in the "Setting the Controls" on page 8 of "Using Your Battery Charger."
  9. In the MANUAL mode at the 60-Amp charging rate, the METER will show a charge rate of 25 to 30 amps or less when the battery is at or near full charge. At the 20-Amp charging rate, the METER will show a charge rate of 8 to 10 amps or less when the battery is at or near full charge. At the 2-Amp charging rate, the METER will show a charge rate of .75 to 1 amp when the battery is at or near full charge.
  10. TO AVOID OVERCHARGING in the Manual Mode, monitor the METER frequently.
  11. When the battery is fully charged, turn the POWER switch to the OFF position and unplug the charger power cord.
  12. Standing away from the battery, remove the charger leads. Remove the grounded clamp first, then the one on the battery.
  13. Clean and store the battery charger in a dry location.

### Charging your battery outside the vehicle:

1. Remove the battery from vehicle, making sure to disconnect grounded terminal first with all accessories and lights turned off in the vehicle.
2. Check the polarity of the **battery** posts as indicated on the battery case: POSITIVE (POS, P, +) and NEGATIVE (NEG, N, -).  
**NOTE:** On top-post batteries, the positive battery terminal usually has a larger diameter post than the negative one.
3. Connect the red (POSITIVE) charger clamp to the POSITIVE post of the battery. Be sure to rock the clip back and forth to make a solid connection.
4. Attach a 6-gauge (AWG) or a 4-gauge (SAE) insulated battery cable of at least 24-inches in length to the NEGATIVE battery post. This cable will provide a safer connection because arcing and sparking will occur away from the battery. (The battery cable is not provided with the charger, but may be purchased at most automotive accessory outlets.)
5. Standing as far away from the battery as possible, connect the black (NEGATIVE) lead of the charger to the free end of the cable. Rock the clamp to make a solid connection. **IMPORTANT:** Wear safety glasses and face away from the battery while making this final connection.

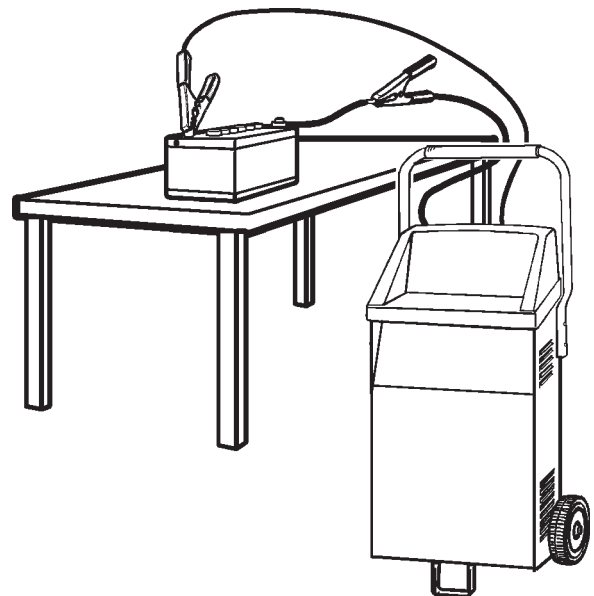

# Calculating charge times

## The Chart Method

Use the following table to more accurately determine the time it will take to bring a battery to full charge. First, identify where your battery fits into the chart.

- Small batteries — motorcycles, garden tractors, etc. — are usually rated in Ampere Hours (**AH**). For example: 6, 12, 32 AH etc.
- Batteries in cars and smaller trucks are usually rated in Reserve Capacity (**RC**), Cold-Cranking Amps (**CCA**), or both.

- Marine, or deep-cycle batteries are usually rated in Reserve Capacity (**RC**).
- **NR** means that the charger setting is **NOT RECOMMENDED**.

Find your battery's rating on the chart below and note the charge time given for each charger setting. The times given are for batteries with a **50-percent charge** prior to recharging. Add more time for severely discharged batteries.

BATTERY SIZE/RATING			CHARGE RATE/CHARGING TIME - HOURS		
			2 AMP	20 AMP	60 AMP
SMALL BATTERIES	Motorcycle, garden tractor, etc.	6 - 12 AH	2 - 4	NR	NR
		12 - 32 AH	4 - 10	NR	NR
CAR/TRUCKS	200 - 315 CCA	40 - 60 RC	11 - 14	1 - 1½	¾ - ½
	315 - 550 CCA	60 - 85 RC	14 - 18	1½ - 2	½ - ⅝
	550 - 1000 CCA	85 - 190 RC	18 - 35	2 - 3½	⅝ - 1
MARINE/DEEP CYCLE		80 RC	18	1¾	NR
		140 RC	27	2¾	NR
		160 RC	30	3	NR
		180 RC	33	3½	NR

## The Hydrometer or Electronic Method

To find the time needed to fully charge your battery, determine the battery's charge level with a hydrometer or electronic Percent-of-Charge Tester. The following table will help you convert hydrometer readings to percent of charge values.

SPECIFIC GRAVITY	PERCENT OF CHARGE	PERCENT OF CHARGE NEEDED
1.265	100%	0%
1.225	75%	25%
1.155	25%	75%
1.120	0%	100%

When you know the percent of charge and the Amp Hour (AH) rating of your battery, you can calculate the approximate time needed to bring your battery to a full charge.

To **convert** Reserve Capacity to Amp Hours, divide Reserve Capacity by 2, and add 16:

$$\text{Amp Hours} = \frac{\text{Reserve Capacity}}{2} + 16$$

## To calculate time needed for a charge:

- Find the percent of charge needed. (A battery at 50 percent charge that will be charged to 100 percent needs another 50 percent (.50)).
- Multiply the Amp Hour rating by the charge needed (.50) and divide by the charger setting (2, 20 or 60 amps).
- Multiply the result by 1.25 and you'll have the time needed, in hours, to bring the battery to full charge.
- Add one additional hour for a deep-cycle battery.

### Example:

$$\frac{\text{Amp Hour Rating} \times \% \text{ of charge needed} \times 1.25}{\text{Charger Setting}} = \text{hours of charge}$$

$$\frac{100 \text{ (AH Rating)} \times .50 \text{ (charge needed)} \times 1.25}{20 \text{ (Charger Setting)}} = 3.125 \text{ hours}$$

$$\frac{100 \times .50}{20} = 2.5 \times 1.25 = 3.125$$

You would need to charge your 100-Ampere Hour Battery for a little more than 3 hours at the 20-Amp charge rate using the above example.

---

## Using the engine start feature

Your battery charger can be used to jump-start your car if the battery is low. Follow these instructions when using the ENGINE START feature.

1. Set the POWER switch to the OFF position. Then follow the instructions for connecting the charger to the battery and power source in the section "Charging a battery in the vehicle."
2. Set the BATTERY switch to 6V or 12V to match the battery's voltage.
3. Set the POWER switch to the ON position. The METER display will show MAN (manual mode).
4. Touch RESET, MANUAL and ENGINE START PADS in that order. Wait for the display to show RDY. The charger is now ready to have the engine cranked.
5. Crank the engine for **no more than 5 seconds**. If it does not start, wait 4 minutes. (The display will show WAIT during this time and RDY when the time is up.)
6. During extremely cold weather, or if the battery is severely exhausted, charge the battery for about 5 minutes before cranking the engine.
7. If the engine still does not start, charge the battery for five more minutes before cranking it again for three seconds.
8. After the engine starts, unplug the charger power cord from the outlet. Then move the POWER switch to the OFF position before disconnecting the battery leads.

---

## Maintenance and care

A minimal amount of care can keep your battery charger working properly for years.

1. Clean the clamps each time you are finished charging. Wipe off any battery fluid that may have come in contact with the clamps to prevent corrosion.
2. Coil the input and output cords neatly when storing the charger. The cords can be wrapped around the handle of the charger. This will help prevent accidental damage to the cords and charger.
3. Occasional cleaning of the case with a soft cloth will keep the finish shiny and help prevent corrosion.



# Troubleshooting

Performance problems often result from little things that you can fix yourself. Please read through this table for a possible solution if a problem occurs.

PROBLEM	POSSIBLE CAUSE	SOLUTION/REASONS
No reading on the ammeter.	Clamps are not making a good connection.	Check for poor connections at battery and frame. Make sure connecting points are clean.
No reading on meter. Charger fan not working.	AC cord and/or extension cord is loose.	Check power cord and extension cord for loose fitting plug.
	No power at receptacle.	Check for open fuse or circuit breaker supplying AC outlet.
In MANUAL Mode, circuit breaker in charger cycles on and off with a clicking sound.	Shorted battery clamps.	Circuit breaker cycles when current draw is too high. Check for shorted cables and replace if needed.
	Shorted battery.	Have a Sears Service Center test the battery.
	Charger leads reversed.	Correct connections.
	Charger set at the START position.	Correct touch-pad settings.
Cranking times less than 3 seconds when using ENGINE START	Drawing more than 275 amps. (12V)	Crank time varies with the amount of current drawn. If cranking draws more than 275 amps, crank time may be less than 3 seconds.
	Failure to wait for 4 minutes (240 seconds) between cranks.	Wait until the METER displays RDY.
Meter reads less than selected charge rate when charging a discharged battery.	Extension cord too long.	Use shorter or heavier gauge extension cord.
	Weak cell or sulfated plate in battery.	Sulfated battery will eventually take a normal charge if left connected. If the battery will not take a charge, have it tested by a Sears Service Center.
	Battery is only partially discharged.	Continue to charge battery.
Charger makes a loud buzz or hum.	Transformer laminations vibrate (buzz).	Continue charging. Buzz is not abnormal.
	Shorted diode (hum).	Have charger tested by a Sears Service Center.
METER reading stays high.	Battery severely discharged.	Continue charging battery for two more hours. If problem continues, call Sears Service at 1-800-SEARS-64.
	Wrong battery voltage selected.	Make sure BATTERY Voltage Select switch is in proper 6 or 12 volt position

**If the above solutions do not eliminate the problem...**  
**call toll-free from anywhere in the U.S.A.**  
**1-800-SEARS-64**  
**(1-800-732-7764)**  
**7 AM to 4:30 PM CT Monday through Friday**

For information about troubleshooting, call toll-free from anywhere in the  
U.S.A. 7 am to 4:30 pm CT Monday through Friday.  
**1-800-SEARS-64 (1-800-732-7764).**

For repair parts or the location of a Sears Parts and Repair Center call:  
**1-800-4-MY-HOME® (1-800-469-4663).**