

OPERATING INSTRUCTIONS

FOR

Model 318R

Trace Oxygen Analyzer

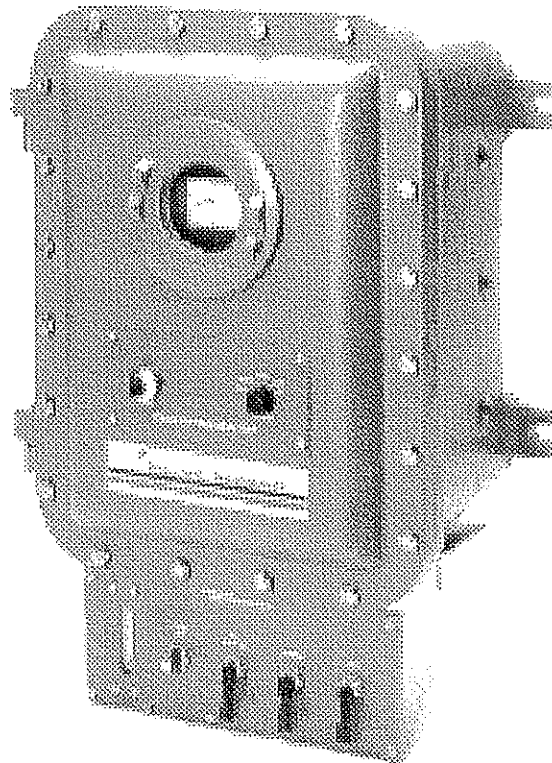

P/N M35161
8/25/94
pm5:318

Copyright © 1994 Teledyne Brown Engineering Analytical Instruments

All Rights Reserved. No part of this manual may be reproduced, transmitted, transcribed, stored in a retrieval system, or translated into any other language or computer language in whole or in part, in any form or by any means, whether it be electronic, mechanical, magnetic, optical, manual, or otherwise, without the prior written consent of Teledyne Brown Engineering Analytical Instruments, 16830 Chestnut Street, City of Industry, CA 91749-1580.

Warranty

This equipment is sold subject to the mutual agreement that it is warranted by us free from defects of material and of construction, and that our liability shall be limited to replacing or repairing at our factory (without charge, except for transportation), or at customer plant at our option, any material or construction in which defects become apparent within one year from the date of shipment, except in cases where quotations or acknowledgements provide for a shorter period. Components manufactured by others bear the warranty of their manufacturer. This warranty does not cover defects caused by wear, accident, misuse, neglect or repairs other than those performed by Teledyne or an authorized service center. We assume no liability for direct or indirect damages of any kind and the purchaser by the acceptance of the equipment will assume all liability for any damage which may result from its use or misuse.

We reserve the right to employ any suitable material in the manufacture of our apparatus, and to make any alterations in the dimensions, shape or weight of any parts, in so far as such alterations do not adversely affect our warranty.

Important Notice

This instrument provides measurement readings to its user, and serves as a tool by which valuable data can be gathered. The information provided by the instrument may assist the user in eliminating potential hazards caused by his process; however, it is essential that all personnel involved in the use of the instrument or its interface, with the process being measured, be properly trained in the process itself, as well as all instrumentation related to it.

The safety of personnel is ultimately the responsibility of those who control process conditions. While this instrument may be able to provide early warning of imminent danger, it has no control over process conditions, and it can be misused. In particular, any alarm or control systems installed must be tested and understood, both as to how they operate and as to how they can be defeated. Any safeguards required such as locks, labels, or redundancy, must be provided by the user or specifically requested of Teledyne at the time the order is placed.

Therefore, the purchaser must be aware of the hazardous process conditions. The purchaser is responsible for the training of personnel, for providing hazard warning methods and instrumentation per the appropriate standards, and for ensuring that hazard warning devices and instrumentation are maintained and operated properly.

Teledyne Brown Engineering Analytical Instruments (TBE/AI), the manufacturer of this instrument, cannot accept responsibility for conditions beyond its knowledge and control. No statement expressed or implied by this document or any information disseminated by the manufacturer or its agents, is to be construed as a warranty of adequate safety control under the user's process conditions.

Table of Contents

1	Introduction	
1.1	Main Features	1-1
1.2	Optional Features	1-2
1.3	Panel Controls	1-3
2	Operation	
2.1	Sensor Description	2-1
2.2	Sample System Description	2-1
2.2	Installation and Operating Procedures	2-3
2.2.1	Precautions	2-3
2.2.2	Location	2-4
2.2.3	Sample Line Installation	2-4
2.3	Vent Connection	2-5
2.4	Electrical Requirements	2-5
2.4.1	AC Power	2-5
2.4.2	Signal	2-5
2.5	Alarm Relays (Optional)	2-6
2.6	Meter Zero	2-6
2.7	Electrical Startup	2-6
2.8	Calibration	2-7
2.8.1	Span Calibration	2-7
2.8.2	Calibration Procedure	2-7
2.9	Setting the Alarms	2-8
2.10	Normal Operation	2-8
2.10.1	Sample Flow	2-8
2.10.2	Calibration Period	2-8
2.10.3	Shutdown and Startup of Sample Flow	2-8
3	Maintenance	
3.0	Introduction	3-1
3.1	Fuse Replacement	3-1
3.2	Sensor Replacement	3-1
3.3	Spare Cells	3-2
3.4	Warranty Conditions	3-3

4 Troubleshooting

4.1 Troubleshooting Guide 4-1

Appendix 1

Specifications A-1
Recommended Spare Parts List A-3
Reference Drawings A-4
Specification Data A-5
Material Safety Data Sheet A-6

Introduction

The Teledyne Brown Engineering Analytical Instruments (TBE/AI) Model 318R Trace Oxygen Analyzer uses a unique Micro-Fuel Cell to measure the concentration of oxygen in a gas stream. The cell has an absolute zero and produces a linear output from the low parts per million (PPM) level through the percent ranges and, therefore, requires no zero gas. When coupled with a “state of the art” two stage amplifier system that incorporates operational amplifiers, the cell provides linear trace oxygen analysis in the standard ranges of 0-10, 0-100, 0-1000, and 0-10,000 PPM. The cell is specific for oxygen and is not influenced by sample flow rate or the presence of hydrocarbons or halogenated hydrocarbons. The instrument may be calibrated with air (eliminating the need for certified trace oxygen calibration gases).

1.1 Main Features

The Model 318R is a sophisticated analytical tool for online oxygen analysis. It is ideally suited for field mounted applications requiring trace analysis of oxygen levels in the PPB or PPM range in a variety of gases or gas mixtures. The main features of this instrument are:

- **Maintenance-Free Sensor.** Teledyne’s Class B-2 Micro-Fuel Cell oxygen sensor is a sealed electrochemical transducer with no electrolyte to change or electrodes to clean. When the cell reaches the end of its useful life (6 months minimum), it is simply removed and replaced.
- **Temperature Compensation.** The Model 318R includes a built-in temperature compensation circuit for greater accuracy.

-
- **Meter Readout.** The Model 318R is equipped with an accurate panel meter which gives direct readout of the analysis. A linear 100 division scale gives reliable, accurate readout of the analysis at any point on the scale. A digital panel meter is optional.
 - **Output Signal.** For applications requiring a continuous recording of the oxygen analysis, a linear output signal from 0-1 mV to 0-1 volt DC is available at no extra charge.
 - **Multiple Ranges of Analysis.** The Model 318R provides four standard ranges of analysis: 0-10, 0-100, 0-1,000 and 0-10,000 PPM, plus a CAL range, which allows instrument calibration using air.
 - **Speed of Response.** Fast response is a key feature of the Model 318R. On the 0-1,000 and 0-10,000 PPM ranges, 90% response time is less than 10 seconds (at 25 deg. C).
 - **Sample Handling System.** The Model 318R incorporates a simple system that includes control valves for sample and span (air) gases, stainless steel tubing and fittings, a sensor shutoff valve, and a flowmeter. The measurement provided by the Model 318R is not flow sensitive, however a flowmeter is included in the system to provide nominal flow control and to verify that there is gas flow through the analyzer.
 - **Explosion-Proof Housing.** The Model 318R's NEMA 7 enclosure is rated for use in Class 1, Division 1, Groups C and D hazardous areas (Group B is optional). The Model 318R easily and conveniently bolts to a wall or bulkhead.

1.2 Optional Features

The following optional features for the Model 318R are available:

- **Current Output Signal.** Grounded or isolated outputs, i.e. 4-20 mA dc, 1-5 mA dc, 10-50 mA dc, can be included in the Model 318R for interface to external devices, such as computers, recorders, etc.
- **Integral Alarm- Circuitry.** The Model 318R provides independently adjustable control circuits for one (1) or two (2) alarms. The alarms are fully adjustable throughout the scale using the controls located inside the housing on the back of the front door panel.

1.3 Panel Controls

A—Meter Readout:

Provides accurate linear 100 division scale readout of the analysis (labeled 0-10 PPM).

B—Range Selector Switch:

Identifies (by the multiplying factor) the basic 10 major divisions of the integral meter scale (i.e. X1 = 0-10 PPM range, X10 = 0-100 PPM range, etc.).

C—Span Potentiometer:

Used for calibration.

D—Sample- Flowmeter:

Contains the throttle valve (P/N V41) and flowmeter (P/N F45) to set the sample flow.

E—Cell Shutoff Valve (P/N V43):

Isolates the vent side of the cell from atmosphere. (for the RA version, this valve is located on the internal piping system).

F—Sample Toggle Valve (P/N V43):

Used to open or close the sample line.

G—Span Toggle Valve (P/N V43):

Used to open or close the span line.

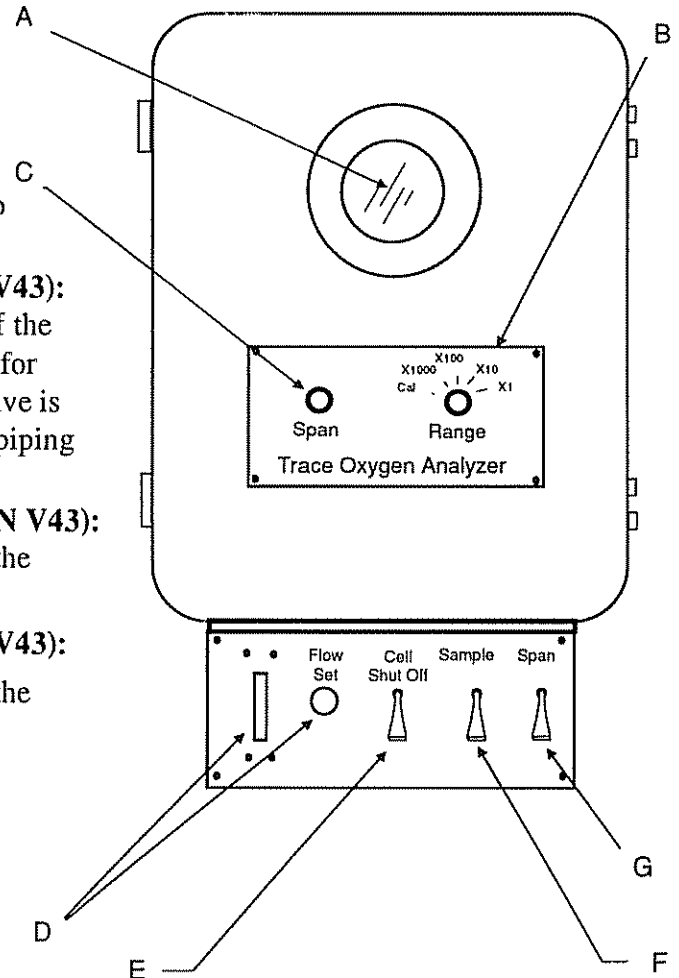



Operation

2.1 Sensor Description

The Model 318R uses a Class B-2 Micro-Fuel Cell for the measurement of trace oxygen. This Micro-Fuel Cell is an electrochemical transducer whose features include:

- Specificity for oxygen
- Maintenance free
- Long interval between calibration
- Disposable configuration
- Long life

The transducer functions as a fuel cell. Oxygen diffusing into the cell reacts electrochemically to produce an electrical current that is proportional to the oxygen concentration in the gas phase immediately adjacent to the sensing surface of the cell.

The Class B-2 Micro Fuel Cell is a general purpose trace oxygen sensor suitable for applications involving inert gas and hydrocarbon mixtures as background. Other sensors are available for use in applications involving CO₂ or lighter gases and are tabulated below.

Sensor Class	Typical Background	Application
B-2	N ₂ , Ar, Hydrocarbon	General purpose
B-2C	H ₂ , He, C ₂ H ₄	Lighter gases, CO ₂ free
A-2C	CO ₂	5–100% CO ₂ , H ₂ free
A-2CI	CO ₂	1–30% CO ₂ and H ₂

2.2 Sample System Description

Figure 2-1 shows a typical piping layout for trace oxygen analysis. The Model 318R contains a throttle valve (needle valve) for sample flow control. The integral flow path also features a shutoff valve and a flowmeter located downstream from the Micro-Fuel Cell holder block. When the cell shutoff and throttle (needle) valves are closed, the cell is isolated from the high oxygen concentration of air. Before shipment, the sample system is purged with nitrogen. When the instrument shows a stable, low PPM oxygen level, the two valves are closed, maintaining the cell in a virtually oxygen free atmosphere until the valves are opened.

Note: To ensure short start-up time and cell conservation, do not open the shutoff valve and throttle valve until completing the installation procedure and initiating sample flow.

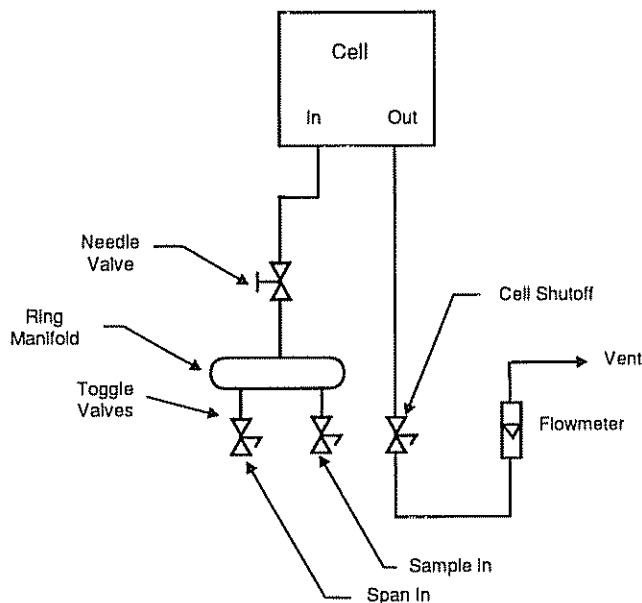

Figure 2-1: Typical Piping Layout

2.2 Installation and Operating Procedures

2.2.1 Precautions

1. Upon receipt of the Model 318R Oxygen Analyzer, inspect the entire unit. **Read the manual before making any connections to the instrument.**
2. Do not scratch, puncture, or damage the sensing membrane (screen surface) of the Micro-Fuel Cell. Damage to the membrane will require replacement of the sensor.
3. The Micro-Fuel Cell contains a caustic mixture which is harmful if touched, inhaled, or swallowed. Avoid contact with ANY fluid or powder in or around the cell or unit. In case of eye contact, immediately flush eyes with water for at least 15 minutes. Call a physician. See the Material Safety Data Sheets (MSDS) in the Appendix for additional health related information.
4. Micro-Fuel Cells are often installed before shipment. If not, the Micro-Fuel Cell must be installed before operating the Model 318R as described in Section 3.2 Sensor Replacement.
5. The throttle valve and the shutoff valve should remain CLOSED until the analyzer is installed and ready to use.
6. All accessory hardware and fittings upstream from the analyzer should be leak tested under pressure before start-up to prevent false readings upon start-up.
7. Check electrical wiring installation against the Interconnection Diagram before start-up to prevent accidental wiring transposition.

2.2.2 Location

The Model 318R Oxygen Analyzer should be installed at viewing level in a sheltered area. The analyzer case is not considered water tight.

Note: Auxiliary heating **MUST** be provided in areas where the ambient temperature drops below 32°F.

For the location and identification of the gas line, electrical connections, and physical dimensions of the analyzer, see the Outline Diagram.

The location and identification of the gas line, electrical connections, and physical dimensions of the analyzer are also shown on the Outline Diagram. When the unit is fully assembled and interconnected with correctly installed rigid conduit, the unit is moisture tight, and meets hazardous area specifications.

2.2.3 Sample Line Installation

Gas Connections: The sample and span inlet connections are 1/8" tube fitting and the sample outlet is 1/4" tube fitting. Connections are identified on the Outline Diagram. TBE/AI suggests using a Teflon sealing tape as a sealant rather than pipe dope.

Note: Be sure that mating fittings are not cross threaded before applying force with a wrench.

Pressure Reduction or Regulation: /AI TBE recommends that the sample pressure be reduced **at the sample point** to between **5 and 50 psig (10 psig nominal)**. If the magnitude of the sample pressure does not exceed 100 psig and is reasonably stable, a simple throttle valve will be satisfactory. However, if the pressure exceeds 100 psig or oscillates over a wide range, a metallic diaphragm pressure regulator should be used.

Caution: If using a certified composition span gas, its supply cylinder must also be equipped with a metallic diaphragm regulator. **DO NOT USE A REGULATOR EQUIPPED WITH AN ORGANIC MATERIAL DIAPHRAGM UNDER ANY CIRCUMSTANCES.** These diaphragms are not impervious to oxygen.

Zero (or near zero) Pressure Sampling: In applications where the sample pressure is either zero or near zero, TBE/AI recommends placing a sample pump downstream from the analyzer (must be specified at the time of purchase). This draws sample through the analyzer from the sample point. TBE/AI rearranges the integral sampling path so the throttle valve is downstream from the cell. This prevents the cell from experiencing a partial vacuum, which may damage the cell and/or cause leaks in the cell manifold block.

2.3 Vent Connection

The Model 318R Oxygen Analyzer should vent directly to the atmosphere. If venting directly is not possible, the following conditions must be met in any vent line installation:

1. The vent line must be constructed of 1/4 inch tubing (or equivalent), so that no back pressure results from restricted flow.
2. The vent line must end in an area that experiences no more than normal barometric pressure changes.
3. The vent line must be installed so that water and dirt cannot accumulate in it.

2.4 Electrical Requirements

All wiring connections are at the terminal strips, located on the mother board. All Power, output signals, and alarm relay wiring locations are shown on the Interconnection Diagram.

2.4.1 AC Power

A source of single phase, 115 volt, 50 or 60 Hz is needed to operate the Model 318R analyzer (100/220 VAC is optional). Polarize the power connections as shown on the Interconnection Diagram (HOT to the terminal identified "H"; NEUTRAL to the "N" terminal).

An equipment ground wire of the same gauge as the power service (nominally 16 gauge) connects to the terminal identified "G." This connection must be made to give the electronic circuitry a proper earth ground reference, and also provides short circuit protection for operating personnel.

2.4.2 Signal

All models of the Model 318R provide an output signal. The magnitude of the available signal can be preset by TBE/AI from 0-1 mV dc (full scale) to 0-1 V dc (full scale) at the time of purchase. Unless otherwise specified, the output is 0-1 VDC. See any Addendum that may have been included with this manual. The voltage output signal, regardless of magnitude, is suitable for driving external devices that have an input impedance of 10,000 ohms or more.

Note: For interconnection purposes, use a two conductor shielded cable (particularly for instruments whose output signal magnitude is in the lower mV range). Polarize the signal connections as shown on the Interconnection Diagram, and connect the shield at the analyzer only.

2.5 Alarm Relays (Optional)

The Model 318R may have one or two fully adjustable alarm contacts. The alarm relays are form “C” (normally closed-common-normally open) DPDT contacts rated at 3 amperes resistive. The alarm relays are factory set to energize either above or below the set point as specified at the time of purchase. Power connections are on the terminal strip. See the interconnection diagram for terminal connections. See any addendum that may have been included with this manual for specific information on your particular alarm configuration.

2.6 Meter Zero

Before turning the power on, check the mechanical zero of the meter and adjust if the meter is reading off zero.

Note: Never adjust the mechanical zero with the power on.

The meter pointer should be aligned with the zero mark of the scale. Adjust the screw on the face of the meter until the pointer shows exactly zero. Digital meters require no mechanical zero adjustment.

2.7 Electrical Startup

Place the range switch in the X-100 scale (0-1000 PPM), and turn on the power. The meter will move upscale and come to equilibrium at a point that represents the concentration of oxygen in the sampling system between the throttle valve and shutoff valve. If the meter reads offscale, refer to the Section 4, Troubleshooting.

2.8 Calibration

2.8.1 Span Calibration

The Model 318R should be calibrated using a span gas with a known oxygen concentration. Ambient air (20.9%) may be used for calibration.

Note: After an air calibration, a longer waiting period is required before the analyzer can be used again for trace analysis.

The waiting period following air calibration can be minimized by using a span gas with a low oxygen concentration.

The analyzer may be calibrated on any range. The span gas concentration should be within 70% to 99% of full scale of the range selected.

Prior to calibration, allow the analyzer reading to come to a reasonably stable value with zero or sample gas flowing through the analyzer.

2.8.2 Calibration Procedure

1. Place the range switch on the selected calibration range.

Note: When calibrating with air (20.9%) set the range switch to the "CAL." position.

2. Open the span toggle valve and allow the span gas to flow through the analyzer.
3. Adjust the flow to approximately 2 SCFH.
4. Wait for the analyzer reading to stabilize.
5. Unlock and turn the span control knob until the analyzer reading equals the oxygen content of the span gas.

Note: When calibrating with air use the "CAL" mark (20.9%).

6. Lock the span control knob.
7. Close the span toggle valve.
8. Open the sample toggle valve and allow the sample gas to flow through the analyzer.

2.9 Setting the Alarms

The alarms are set using the adjustable front panel controls, and are fully adjustable (0-100%) on the range selected. To set the optional alarm(s), use the following example:

If the selected range is 0-1,000 PPM and it is desired to alarm at 400 PPM, set the alarm dial to 40.0 (40% of 1000 PPM).

2.10 Normal Operation

For routine operation of the instrument observe the following guidelines regarding startup, calibration and shutdown.

2.10.1 Sample Flow

Adjust to a maximum of 4 SCFH (a nominal level of 2 SCFH is recommended).

2.10.2 Calibration Period

No prescribed routine calibration period is recommended. TBE/AI feels that the intervals between calibration should be dictated by the customer's application. If the instrument is being used to certify the oxygen content of a product for delivery, then calibration of the instrument before certification is suggested. If the instrument is used to monitor or guard a process for predetermined limits of acceptability, the customer's knowledge of his process and the evidence provided by the instrument will determine when a calibration check is needed.

2.10.3 Shutdown and Startup of Sample Flow

Whenever it becomes necessary to cut off the sample flow, the following procedure minimizes the diffusion of air into the instrument. This maintains the cell in a low PPM oxygen environment.

1. Close the throttle valve completely.
2. Close all toggle valves.
3. Immediately close the cell shutoff valve.

With the valves completely closed, the output indication will eventually come to equilibrium somewhere on the X100 scale as explained in the first paragraph in "Electrical Startup". See section 2.7. When gas flow is to be restarted, open the cell shutoff valve first, and then immediately open the appropriate toggle valve and throttle valve. Then adjust the flow.

Maintenance

3.0 Introduction

Aside from normal instrument cleaning, the only routine maintenance on this instrument involves changing the sensor or replacing blown fuses.

3.1 Fuse Replacement

Occasionally, the need may arise to replace the fuse. If the unit will not turn on when plugged in the following procedure applies:

WARNING: BE SURE ALL POWER IS OFF OR AREA IS DECLASSIFIED BEFORE OPENING THE ANALYZER.

Procedure:

The fuse is located inside the analyzer housing on the mother board. For 110V instruments, remove and replace with a 2A fuse (P/N F10). For 220 V instruments use a 1A fuse (P/N F9).

3.2 Sensor Replacement

The characteristics of the Class B-2 Micro-Fuel Cell are similar to those of a mercury battery. Both provide an almost constant output through their useful life, and then fall off sharply towards zero at the end. Cell failure may be shown by the inability to properly calibrate the analyzer. Very little adjustment of the 10-turn span potentiometer will be required to calibrate the analyzer during the duration of a given cell's useful life. If many turn adjustments (cw) are required to calibrate the instrument, or calibration cannot be achieved within the range of the control, replace with a new Class B-2 Micro-Fuel Cell. To replace the cell, the following procedure applies:

Procedure:

No tools are used to install the Micro-Fuel Cell in the Model 318R. The cell is located behind the hinged front panel inside the cell block assembly.

WARNING: BE SURE ALL POWER IS OFF OR AREA IS DECLASSIFIED BEFORE OPENING THE ANALYZER.

1. Set the analyzer range switch to the CAL position (make sure the power switch is ON).
2. Make sure the sample is flowing through the analyzer. Remove the old cell by unscrewing (ccw) the plug at the bottom of the cell block (the cell will drop out when the plug is removed).
3. It is important to minimize the amount of time the new cell is exposed to air in order to reduce the time required for the reading of the newly installed cell to drop to zero.
4. Remove the new cell from its package, remove the shorting device and position the cell on the cell block plug (contact plate surface facing up). Take care that the cell does not come off the plug flange and that the flange does not scrape across the sensing membrane, causing a leak of electrolyte. Carefully insert the cell into the cell block and tighten the cell block plug to seat the o-ring seal. Set the sample flow to approximately 2 SCFH.
5. Allow the reading to drop to a stable low reading.
6. After replacing the Micro-Fuel Cell, proceed to Calibration. See Section 2.8 for details.

3.3 Spare Cells

To prevent the possibility of not having a replacement cell available when needed, a spare cell should be ordered shortly after placing the Model 318R in service.

Note: Do not over order or stockpile spare cells. Only one cell per instrument should be in reserve.

The spare cell should be stored between 35°F to 80°F. **Do not puncture or otherwise disturb the integrity of the cell package until using the cell.** If the cell package is punctured and air permitted to enter, the cell will take an abnormally long period of time to drop to low PPM levels.

3.4 Warranty Conditions

The Class B-2 cell used in the Model 318R is warranted for six (6) months of service. The B-2 cell should not be used in applications where CO₂ is a major component in the sample. See Figure 3-1 for the effect of CO₂ on cell life. Concentrations of 1,000 PPM or less will not effect the cell performance. Alternative cells are available for either intermittent or continuous CO₂ exposure. See Section 2.1 for a description of alternative cell classes available.

Customers having warranty claims must return the cell in question to the factory for evaluation. If it is determined that failure is due to faulty workmanship or material, the cell will be replaced free of charge.

Note: Evidence of tampering or mishandling will render the cell warranty null and void. If a cell was working satisfactorily, but falls short of its warranty period, the customer will receive credit, on a pro-rated basis, toward the purchase of a new cell. Contact your local representative or the factory for a return material number before returning any defective item.



Notes:

1. This curve assumes continuous exposure.
2. Intermittent exposure will extend life. In general, the CO₂ effect is cumulative and the average CO₂ concentration should be used to find the predicted cell life.
3. Cells can be used to make spot check measurements of O₂ in the presence of high concentrations of CO₂ (up to 50% and more). The CO₂ containing sample should be purged out as soon as a constant reading is obtained.
4. Abnormally slow response and recovery is characteristic of cells operated as indicated in notes 1, 2, and 3.
5. The reduction in cell life is primarily due to a drop in output. This reduces to a point where the instrument can no longer be spanned. Instruments using B-2 cells in CO₂ atmospheres should be spanned more frequently (at intervals 10-20% of the predicted life).
6. The CO₂ effect on B-2 cells is independent of the O₂ level. The reduction in cell life due to their being used in CO₂ atmospheres is therefore limiting and takes precedence over the normal warranty.

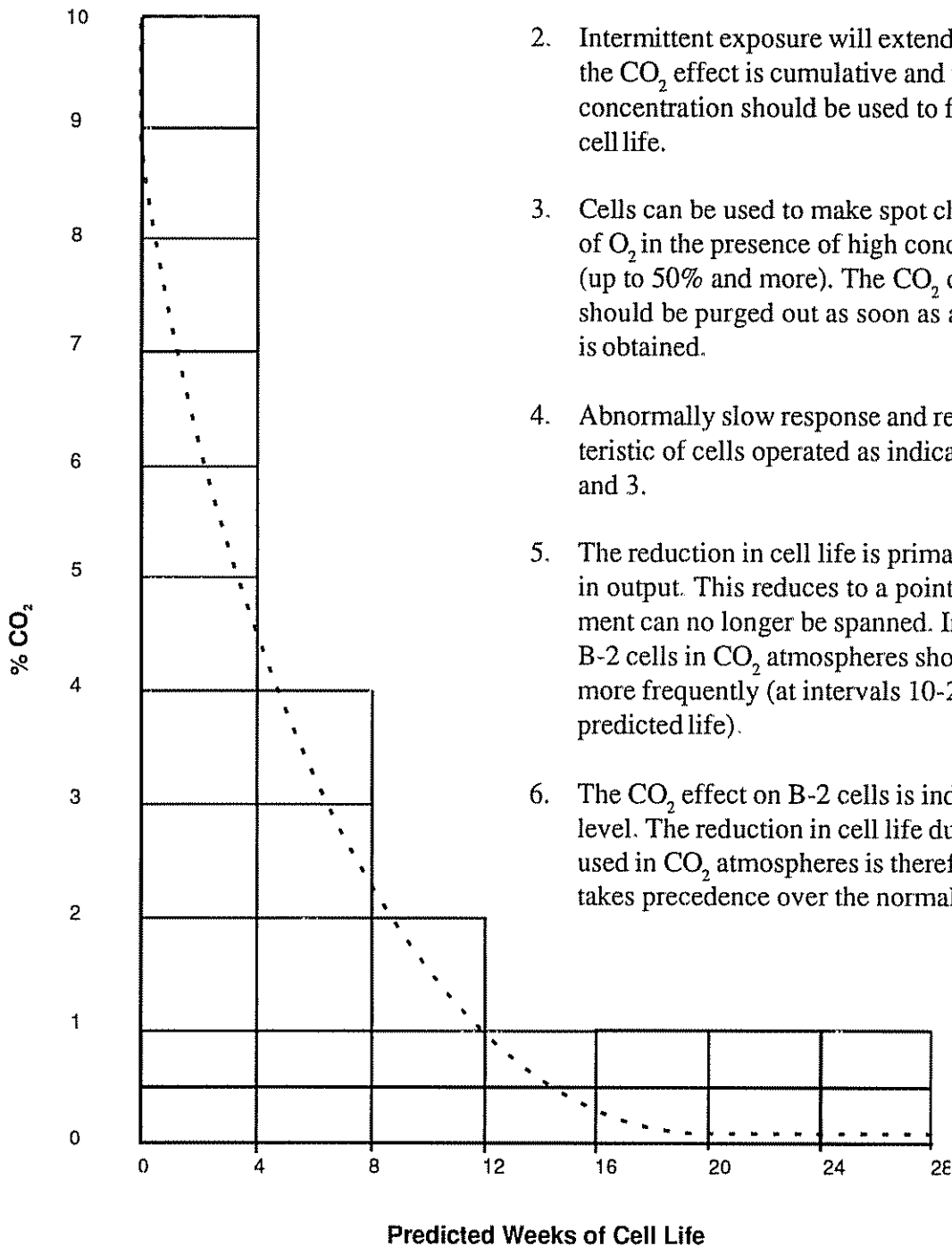

Figure 3-1: Effect of CO₂ on Cell Lifetime

Troubleshooting

Most problems that may occur can usually be resolved by verifying instrument setup against the procedures provided in Section 2, "Installation & Start-Up Procedures". If this does not result in proper operation of the Model 318R, the following checks in this section are to be made. If the problem still cannot be resolved, contact TBE/AI.

4.1 Troubleshooting Guide

SYMPTOM	ACTION
No response from meter.	<ol style="list-style-type: none">1. Check fuse. If OK, follow next step.2. Check +15 VDC (at test points) on power supply board. If OK, follow next step.3. Check output (A1 and A2) on measuring board; if no output, contact TBE/AI.
Meter gives wrong reading.	<ol style="list-style-type: none">1. Turn power off. Adjust mechanical zero, if required.2. Turn power on. Let reading stabilize.3. Increase flow rate (4 SCFH) and observe meter. If reading decreases, there is a leak in the sample lines - correct leak; if reading increases, there may be a restriction in the vent - make sure

**Meter gives wrong reading
(cont.)**

shutoff valve is completely open, check for restrictions in vent line; if reading remains constant, follow next step.

5. Turn power off, remove the red and black wires from measuring board (terminals 1 & 2 on small terminal strip). Note: Short the wires together while disconnected.
6. Turn power on and set range to X1. The meter should read $0 \pm 1/4\%$ of scale. If not, contact TBE/AI.
8. Reconnect red and black wires and allow reading to stabilize. If reading is still incorrect, replace sensor.
9. Contact TBE/AI if incorrect reading continues.

Analyzer will not span to CAL mark.

1. Check sensor for correct cell "Class."
2. Replace sensor.

Analyzer reads over 1,000 PPM upon Electrical Start-Up.

1. A longer length of time is required until the analyzer reading is stable. If the reading is steadily going down, wait until a stable low level is attained.
2. If stable reading is unreasonably high, replace the sensor.

Appendix

Specifications

(Subject to change without notice)

Ranges: Standard: 0-10, 0-100, 0-1,000, 0-10,000, CAL

Sensitivity: 0.5% Full Scale

Accuracy:

At constant temperature: Standard ranges: $\pm 2\%$ Full Scale (except ± 1 PPM for 0-10 PPM range)

Over the operating temperature range: Standard ranges: $\pm 5\%$ Full Scale (except ± 1 PPM for 0-10 PPM range)

Operating Temp Range: 32°F - 122°F (0 C - 50°C)

Voltage Signal Output: 0-1 V DC or less (standard)

Current Signal Output: 1-5, 4-20 or 10-50 mA D.C. (optional)

Alarm Output: (Optional) 1 or 2 DPDT Form C relays (3A resistive)

Alarm Deadband

(Hysteresis): 0.1% Full Scale

Response Time:

(at 77 F, 25 C)

0-10 PPM, 90% in less than 45 sec
 0-100 PPM, 90% in less than 30 sec
 0-1000 PPM, 90% in less than 10 sec
 0-10,000 PPM, 90 in less than 10 sec

- Cell Warranty:** 6 months (Class B-2, B-2C, A-2C, A-2CI)
- Power Requirement:** 115 VAC, 50/60 Hz, 30 W
(100/220 VAC optional)
- Area Classification:** Class 1, Division 1, Groups C and D
(B optional)

Recommended Spare Parts List

QTY.	PART NO.	DESCRIPTION	
1*	B-29600	PC Board	E to I Converter, Isolated
1*	B-14702	PC Board	E to I Converter, Neg. Ground
1*	A-10045	PC Board	Single Alarm
1*	A-9309	PC Board	Dual Alarm
1*	B-43812	PC Board	Cell Failure Alarm
1*	B-30868	PC Board	Temp Controller (115V)
1*	B-36026	PC Board	Temp Controller (220V)
1	A-9306	PC Board	Power Supply
1	C-32129	PC Board	Oxygen Amplifier
1	R179	Relay	(used with alarms)
1	O165	O-Ring	
5	F10	Fuse 2A	(115V) or
5	F9	Fuse	(220V)
1	C6689-B2	Class B-2	Micro-Fuel Cell
**	C6689-B2C	Class B-2C	Micro-Fuel Cell
**	C6689-A2C	Class A-2C	Micro-Fuel Cell
**	C6689-A2CI	Class A-2CI	Micro-Fuel Cell
1	M41	Meter (Meter dial is application specific)	

* These items are options to the standard instrument and unless ordered, they will not be present.

** Optional Class of Micro-Fuel Cell, application specific.

A minimum charge of US \$20.00 is applicable to spare parts orders.

IMPORTANT: Orders for replacement parts should include the model number, serial number, and range of the analyzer for which the parts are intended.

Orders should be sent to:

Teledyne Analytical Instruments
 16830 Chestnut Street
 City of Industry, CA 91749 – 1580

Phone: (626) 934 – 1500, Fax: (626) 961 – 2538

TWX (910)584 – 1887 TDYANLY COID

Web: www.teledyne – ai.com

representative

Reference Drawings

B-34017	Outline Diagram
A-9171	Piping Diagram
C-34015	Schematic, Interconnection
C-31945	Schematic, Mother Board
B-32152	Schematic, Oxygen Amplifier
B-33129	Schematic, Power Supply
B-30974	Schematic, Temperature Control
A-33140	Interconnection Diagram
C-34016	Wiring Diagram

Specification Data

The following information applies to your specific order:

TBE/AI Sales Order Number: _____

Instrument Model Number: _____

Instrument Serial Number: _____

Micro-Fuel Cell Class: _____

Output Signal: _____

Analysis Ranges:

X1:	_____	PPM Oxygen
X10:	_____	PPM Oxygen
X100:	_____	PPM Oxygen
X1000:	_____	PPM Oxygen

Alarm No. 1 Setpoint: _____

Alarm No. 2 Setpoint: _____

Material Safety Data Sheet
Section I – Product Identification

Product Name: Micro-Fuel Cells
 Mini-Micro-Fuel Cells, all classes
 Super Cells, all classes except T-5F
 Electrochemical Oxygen Sensors, all classes.

Manufacturer: Teledyne Brown Engineering Analytical Instruments
Address: 16830 Chestnut Street, City of Industry, CA 91749
Phone: (818) 961-9221

Date Prepared or Last Revised: 08/08/91
 Emergency Phone Number: (818) 961-9221

Section II – Physical and Chemical Data

Chemical and Common Names: Potassium Hydroxide (KOH), 15% (w/v)
 Lead (Pb), pure

CAS Number: KOH 1310-58-3
 Pb 7439-92-1

	KOH (15% w/v)	Pb (pure)
Melting Point/Range:	-10 to 0 °C	328 °C
Boiling Point/Range:	100 to 115 °C	1744 °C
Specific Gravity:	1.09 @ 20 °C	11.34
pH:	>14	N/A
Solubility in Water:	Completely soluble	Insoluble
Percent Volatiles by Volume:	None	N/A
Appearance and Odor:	Colorless, odorless solution	Grey metal, odorless

Section III – Physical Hazards

Potential for fire and explosion: The electrolyte in the Micro-Fuel Cells is not flammable. There are no fire or explosion hazards associated with Micro-Fuel Cells.

Potential for reactivity: The sensors are stable under normal conditions of use. Avoid contact between the sensor electrolyte and strong acids.

Section IV – Health Hazard Data

Primary route of entry: Ingestion, eye/skin contact
Exposure limits:OSHA PEL: .05 mg/cu.m. (Pb)
ACGIH TLV: 2 mg/cu.m. (KOH)

Effects of overexposure

Ingestion: The electrolyte could be harmful or fatal if swallowed.

Oral LD50 (RAT) = 3650 mg/kg

Eye: The electrolyte is corrosive; eye contact could result in permanent loss of vision.

Dermal: The electrolyte is corrosive; skin contact could result in a chemical burn.

Inhalation: Liquid inhalation is unlikely.

Signs/symptoms of exposure: Contact with skin or eyes will cause a burning sensation and/or feel soapy or slippery to touch.

Medical conditions

aggravated by exposure: None

Carcinogenicity: NTP Annual Report on Carcinogens: Not listed
 LARC Monographs: Not listed
 OSHA: Not listed

Other health hazards: Lead is listed as a chemical known to the State of California to cause birth defects or other reproductive harm.

Section V – Emergency and First Aid Procedures

- Eye Contact:** Flush eyes with water for at least 15 minutes and get immediate medical attention.
- Skin Contact:** Wash affected area with plenty of water and remove contaminated clothing. If burning persists, seek medical attention.
- Ingestion:** Give plenty of cold water. Do not induce vomiting. Seek medical attention. Do not administer liquids to an unconscious person.
- Inhalation:** Liquid inhalation is unlikely.

Section VI – Handling Information

NOTE: The oxygen sensors are sealed, and under normal circumstances, the contents of the sensors do not present a health hazard. The following information is given as a guide in the event that a cell leaks.

- Protective clothing:** Rubber gloves, chemical splash goggles.
- Clean-up procedures:** Wipe down the area several times with a wet paper towel. Use a fresh towel each time.
- Protective measures during cell replacement:** Before opening the bag containing the sensor cell, check the sensor cell for leakage. If the sensor cell leaks, do not open the bag. If there is liquid around the cell while in the instrument, put on gloves and eye protection before removing the cell.
- Disposal:** Should be in accordance with all applicable state, local and federal regulations.

NOTE: The above information is derived from the MSDS provided by the manufacturer. The information is believed to be correct but does not purport to be all inclusive and shall be used only as a guide. Teledyne Analytical Instruments shall not be held liable for any damage resulting from handling or from contact with the above product.