



**MILWAUKEE
M4910-10 PAINT SPRAYER
REPAIR SHEET**

**MILWAUKEE
PULVÉRISATEUR À PEINTURE
SANS AIR M4910-10
FEUILLE DE RÉPARATION**

**MILWAUKEE
ROCIADOR DE PINTURA SIN
AIRE M4910-10
LISTA DE PIEZAS DE REPUESTO**

M4910-10

See Figure B
Voir la figure B
Vea la figura B

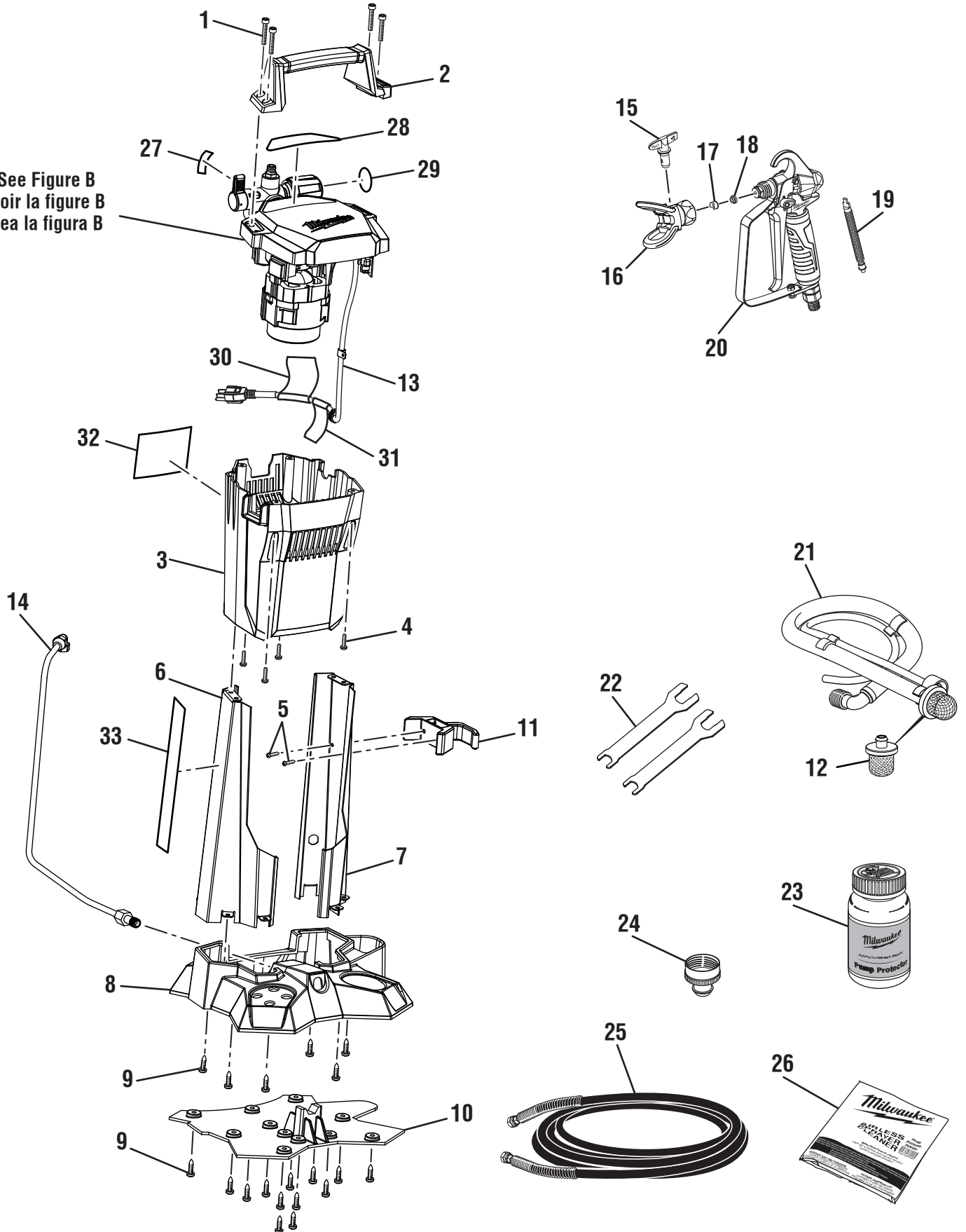

FIGURE A
FIGURE A / FIGURA A

M4910-10

PARTS LIST FOR FIGURE A

KEY NO.	PART NUMBER	DESCRIPTION	QTY.	KEY NO.	PART NUMBER	DESCRIPTION	QTY.
1	039601001001	Screw (M6 x 35 mm).....	4	20	039601001041	Pistol-Grip Sprayer Assembly (Incl. Key Nos. 16-19).....	1
2	039601001002	Handle.....	1	21	039601001063	Intake Tube Assembly (Incl. Key No 12).....	1
3	039601001003	Back Housing.....	1	22	039601001040	Wrench.....	2
4	039747001021	Screw (M5 x 14 mm).....	4	23	039601001042	Plastic Bottle.....	1
5	039601001004	Screw (4.8 x 19 mm).....	2	24	039601001051	Cleaning Adapter.....	1
6	039601001005	Frame (Left).....	1	25	039747001080	High Pressure Hose.....	1
7	039601001006	Frame (Right).....	1	26	039601001050	Cleaning Powder.....	1
8	039601001007	Base.....	1	27	039601001103	Pressure Relief Label.....	1
9	039601001008	Screw (6.3 x 22 mm).....	19	28	039601001105	Data Label.....	1
10	039601001009	Base Cover.....	1	29	039601001102	Pump Regulator Label.....	1
11	039601001010	Wrench Storage.....	1	30	039601001108	Warning Label (French/Spanish).....	1
12	039747001042	Filter.....	1	31	039601001104	Danger Label.....	1
13	039601001061	Power Cord Assembly.....	1	32	039601001106	Warning Label (English).....	1
14	039601001062	Paint Tube Assembly.....	1	33	039601001107	Quick Start Label.....	1
15	039747001178	515 Tip.....	1		NOT SHOWN		
16	039747001187	Tip Guard Assembly.....	1		988000343	Operator's Manual	
17	039747001184	Saddle.....	1		5-11-11		
18	039747001185	O-ring.....	1		(Rev:01)		
19	039747001186	Filter.....	1				

LISTE DES PIÈCES POUR FIGURE A

PIÈCE	RÉF.	DESCRIPTION	QTÉ.	PIÈCE	RÉF.	DESCRIPTION	QTÉ.
1	039601001001	Vis (M6 x 35 mm).....	4	19	039747001186	Filtre.....	1
2	039601001002	Poignée.....	1	20	039601001041	Ensemble de pistolet de pulvérisation (inclure lég. réf. 16 à 19).....	1
3	039601001003	Boîtier arrière.....	1	21	039601001063	Ensemble de tube d'admission (inclure lég. réf. 12).....	1
4	039747001021	Vis (M5 x 14 mm).....	4	22	039601001040	Clé.....	2
5	039601001004	Vis (4,8 x 19 mm).....	2	23	039601001042	Bouteille en plastique.....	1
6	039601001005	Bâti (gauche).....	1	24	039601001051	Adaptateur de nettoyage.....	1
7	039601001006	Bâti (droite).....	1	25	039747001080	Tuyau haute pression.....	1
8	039601001007	Base.....	1	26	039601001050	Poudre de nettoyage.....	1
9	039601001008	Vis (6,3 x 22 mm).....	19	27	039601001103	Étiquette de levier de surpression.....	1
10	039601001009	Couvercle de base.....	1	28	039601001105	Étiquette de données.....	1
11	039601001010	Logement pour clé.....	1	29	039601001102	Étiquette de pompe de régulateur.....	1
12	039747001042	Filtre.....	1	30	039601001108	Étiquette d'avertissement (Français/Espagnol).....	1
13	039601001061	Ensemble de cordon d'alimentation.....	1	31	039601001104	Plaquette de danger.....	1
14	039601001062	Ensemble de tube à peinture.....	1	32	039601001106	Étiquette d'avertissement (Anglais).....	1
15	039747001178	Embout de pulvérisation 515.....	1	33	039601001107	Étiquette de démarrage rapide.....	1
16	039747001187	Ensemble de derotecteur d'embout.....	1		PAS ILLUSTRÉ		
17	039747001184	Selle de renforcement.....	1		988000343	Manuel d'utilisation	
18	039747001185	Joint torique en O.....	1				

LISTA DE PIEZAS PARA FIGURA A

REF.	N/P	DESCRIPCIÓN	CANT.	REF.	N/P	DESCRIPCIÓN	CANT.
1	039601001001	Tornillo (M6 x 35 mm).....	4	19	039747001186	Filtro.....	1
2	039601001002	Mango.....	1	20	039601001041	Conjunto de rociador con empuñadura de pistola (incluir núm. ref. 16 a 19).....	1
3	039601001003	Alojamiento posterior.....	1	21	039601001063	Conjunto de tubo de entrada (incluir núm. ref. 12).....	1
4	039747001021	Tornillo (M5 x 14 mm).....	4	22	039601001040	Llave.....	2
5	039601001004	Tornillo (4,8 x 19 mm).....	2	23	039601001042	Botela del plástico.....	1
6	039601001005	Armazón (izquierda).....	1	24	039601001051	Adaptador de limpieza.....	1
7	039601001006	Armazón (derecha).....	1	25	039747001080	Manguera de alta presión.....	1
8	039601001007	Base.....	1	26	039601001050	Polvo de la limpieza.....	1
9	039601001008	Tornillo (6,3 x 22 mm).....	19	27	039601001103	Etiqueta de liberación de presión.....	1
10	039601001009	Cubierta de la base.....	1	28	039601001105	Etiqueta de datos.....	1
11	039601001010	Almacenamiento de la llave.....	1	29	039601001102	Etiqueta de regulador de la bomba.....	1
12	039747001042	Filtro.....	1	30	039601001108	Etiqueta de advertencia (Francés/Español).....	1
13	039601001061	Conjunto de cordón de corriente.....	1	31	039601001104	Etiqueta de peligro.....	1
14	039601001062	Conjunto de tubo de pintura.....	1	32	039601001106	Etiqueta de advertencia (Inglés).....	1
15	039747001178	Punta de rociado 515.....	1	33	039601001107	Etiqueta sobre el arranque rápido.....	1
16	039747001187	Conjunto de protección para la punta de la boquilla.....	1		NO SE MUESTRA		
17	039747001184	Carro portaherramientas.....	1		988000343	Manual del operador	
18	039747001185	Anillo en "O".....	1				

M4910-10

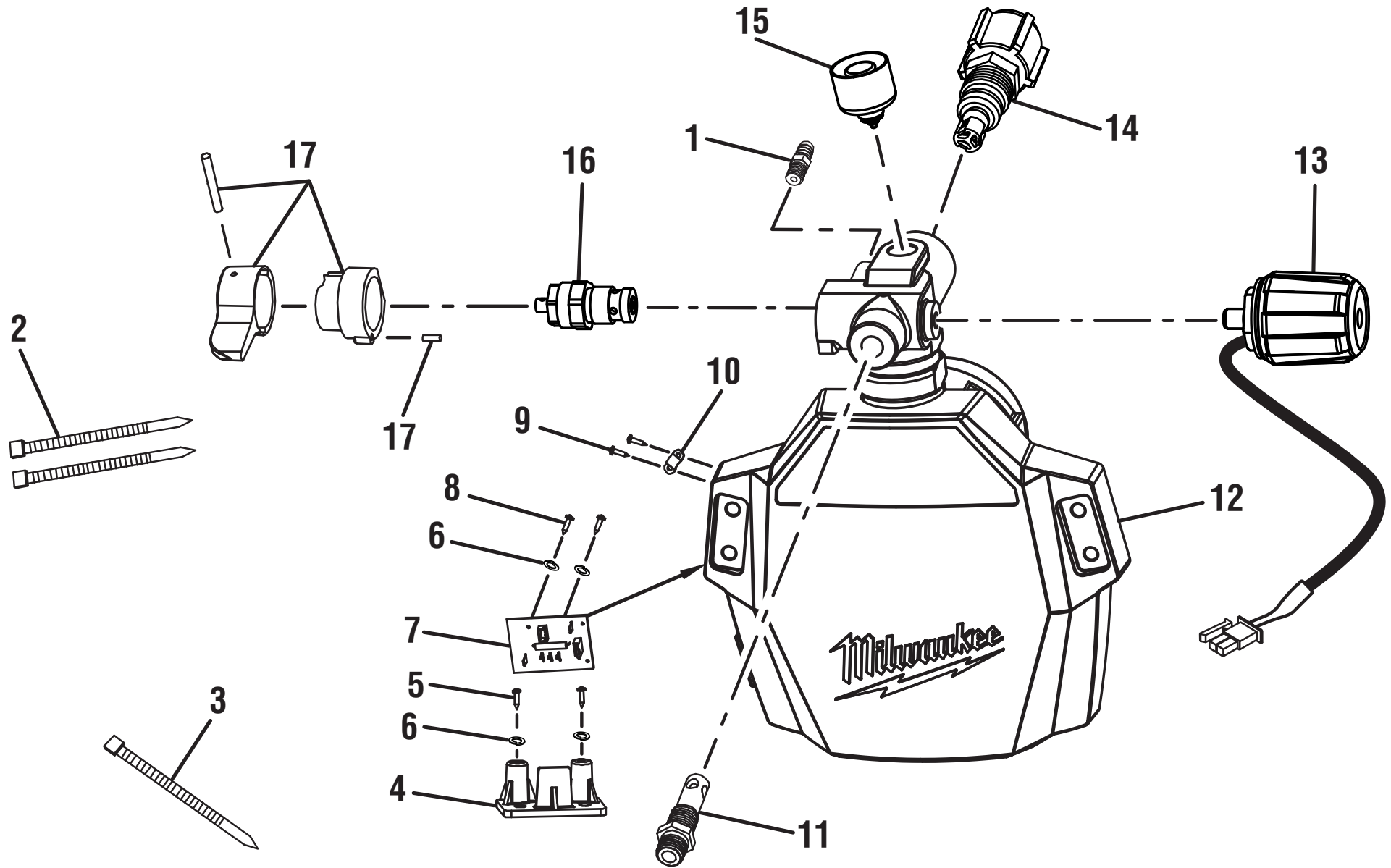

FIGURE B
FIGURE B / FIGURA B

M4910-10

PARTS LIST FOR FIGURE B

LISTE DES PIÈCES POUR FIGURE B

LISTA DE PIEZAS PARA FIGURA B

KEY NO.	PART NUMBER	DESCRIPTION	QTY.	PIÈCE RÉF.	NO. DE PIÈCE	DESCRIPTION	QTÉ.	NÚM REF.	NÚM. PIEZA	DESCRIPCIÓN	CANT.
1	039747001051	Adaptor.....	1	1	039747001051	Adaptateur.....	1	1	039747001051	Adaptador.....	1
2	039601001027	Plastic Tie (1)	2	2	039601001027	Liaison en plastique (1).....	2	2	039601001027	Amarre del plástico (1).....	2
3	039601001026	Plastic Tie (2)	1	3	039601001026	Liaison en plastique (2).....	1	3	039601001026	Amarre del plástico (2).....	1
4	039748001016	PCB Supporter	1	4	039748001016	Support de PCB	1	4	039748001016	Soporte del PCB.....	1
5	039748001017	Screw (M4 x 10 mm).....	2	5	039748001017	Vis (M4 x 10 mm)	2	5	039748001017	Tornillo (M4 x 10 mm)	2
6	039601001053	Lock Washer	4	6	039601001053	Rondelle frein.....	4	6	039601001053	Arandela de fijación	4
7	039601001052	PCB Assembly.....	1	7	039601001052	Ensemble de PCB	1	7	039601001052	Conjunto de PCB.....	1
8	039748001014	Screw (M3.5 x 13 mm).....	2	8	039748001014	Vis (M3,5 x 13 mm).....	2	8	039748001014	Tornillo (M3,5 x 13 mm)	2
9	039748001013	Screw (M4 x 20 mm).....	2	9	039748001013	Vis (M4 x 20 mm)	2	9	039748001013	Tornillo (M4 x 20 mm)	2
10	039747001123	Power Cord Fixer.....	1	10	039747001123	Fixateur le cordon d'alimentation	1	10	039747001123	Fijador de cordón eléctrico....	1
11	039747001156	Outlet Valve Assembly.....	1	11	039747001156	Ensemble valve de sortie.....	1	11	039747001156	Conjunto de montaje de la válvula de salida	1
12	039601001060	Pump Assembly.....	1	12	039601001060	Ensemble de pompe	1	12	039601001060	Conjunto de la bomba.....	1
13	039601001066	Pump Regulator Assembly....	1	13	039601001066	Ensemble de pompe de régulateur.....	1	13	039601001066	Conjunto del regulador de la bomba.....	1
14	039748001150	Inlet Valve Assembly.....	1	14	039748001150	Ensemble valve d'entrée	1	14	039748001150	Montaje de la válvula de entrada	1
15	039601001065	Pressure Release Button	1	15	039601001065	Bouton de commande de libération.....	1	15	039601001065	Botón para soltar el mecanismo de presion	1
16	039748001113	Pressure Relief Valve	1	16	039748001113	Soupape de décharge	1	16	039748001113	Válvula de liberación de presión.....	1
17	039601001064	Pressure Relief Lever.....	1	17	039601001064	Levier de surpression	1	17	039601001064	Palanca de liberación de presión.....	1

M4910-10

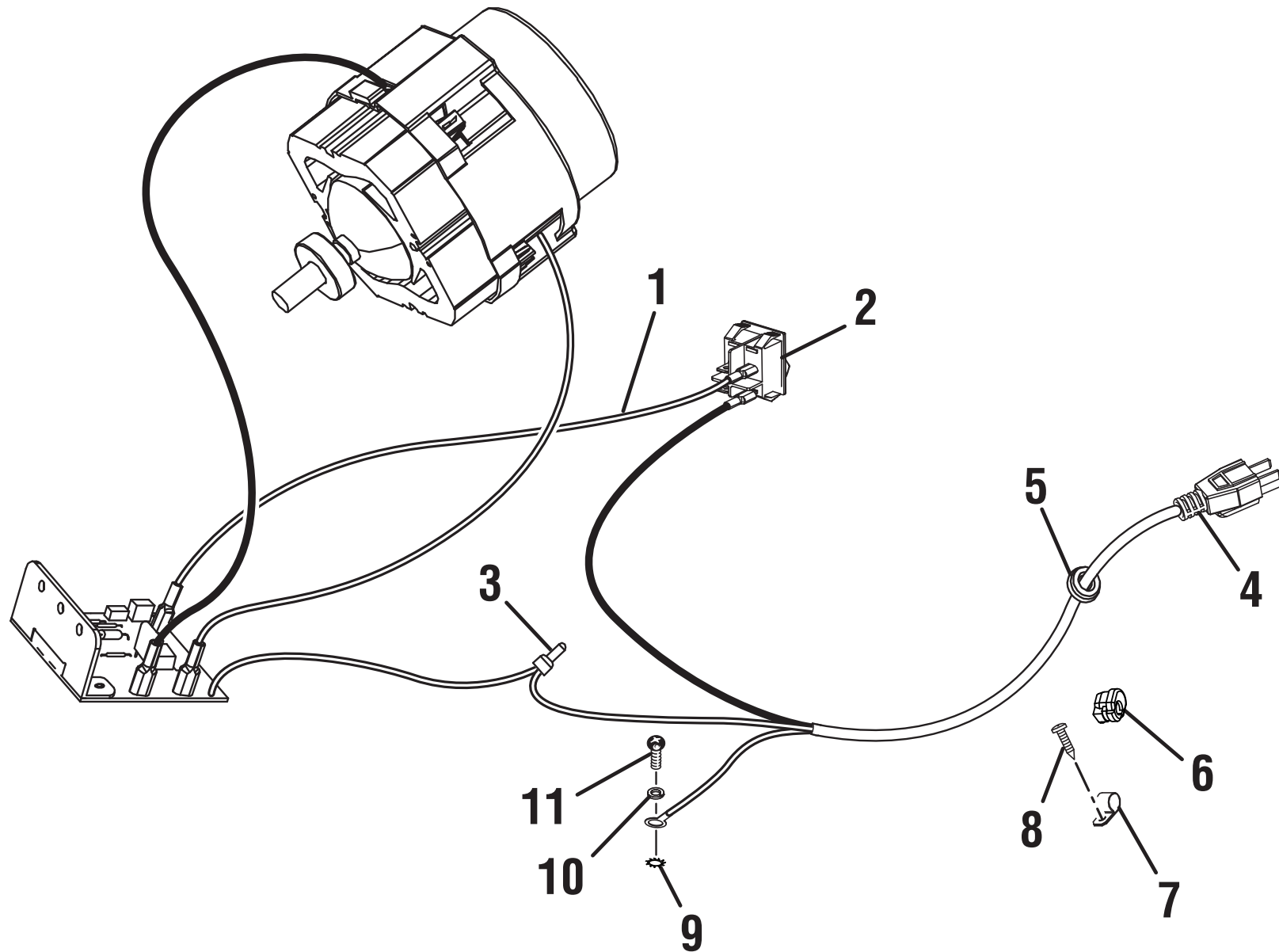

FIGURE C
FIGURE C / FIGURA C

M4910-10

PARTS LIST FOR FIGURE C

LISTE DES PIÈCES POUR FIGURE C

LISTA DE PIEZAS PARA FIGURA C

KEY NO.	PART NUMBER	DESCRIPTION	QTY.	PIÈCE RÉF.	NO. DE PIÈCE	DESCRIPTION	QTÉ.	NÚM REF.	NÚM. PIEZA	DESCRIPCIÓN	CANT.
1	039601001030	Lead W/ Terminal.....1	1	039601001030	039601001030	Fil avec terminal.....1	1	1	039601001030	Cable con terminal1	1
2	039747001087	On/Off Switch1	2	039747001087	039747001087	Interrupteur marche/arrêt1	2	2	039747001087	Interruptor de encendido/apagado1	1
3	039748001081	Wire Connector.....1	3	039748001081	039748001081	Connecteur de fils1	3	3	039748001081	Conector alambre1	1
4	039747001081	Power Cord.....1	4	039747001081	039747001081	Cordon d'alimentation1	4	4	039747001081	Cordón de corriente1	1
5	039748001030	Bend Relief1	5	039748001030	039748001030	Protecteur de cordon.....1	5	5	039748001030	Protector del cordón.....1	1
6	039748001083	Strain Relief1	6	039748001083	039748001083	Soulagement de contrainte ...1	6	6	039748001083	Liberación de tensión1	1
7	039601001031	Cord Clamp1	7	039601001031	039601001031	Retenue de cordon.....1	7	7	039601001031	Abrazadera de cordón.....1	1
8	039601001032	Screw (M3.5 x 6.5 mm).....1	8	039601001032	039601001032	Vis (M3,5 x 6,5 mm).....1	8	8	039601001032	Tornillo (M3,5 x 6,5 mm)1	1
9	039601001033	Star Washer1	9	039601001033	039601001033	Rondelle étoile.....1	9	9	039601001033	Arandela estrellada1	1
10	039601001034	Washer.....1	10	039601001034	039601001034	Rondelle.....1	10	10	039601001034	Arandela1	1
11	039601001035	Screw (M4 x 10 mm).....1	11	039601001035	039601001035	Vis (M4 x 10 mm).....1	11	11	039601001035	Tornillo (M4 x 10 mm)1	1

M4910-10

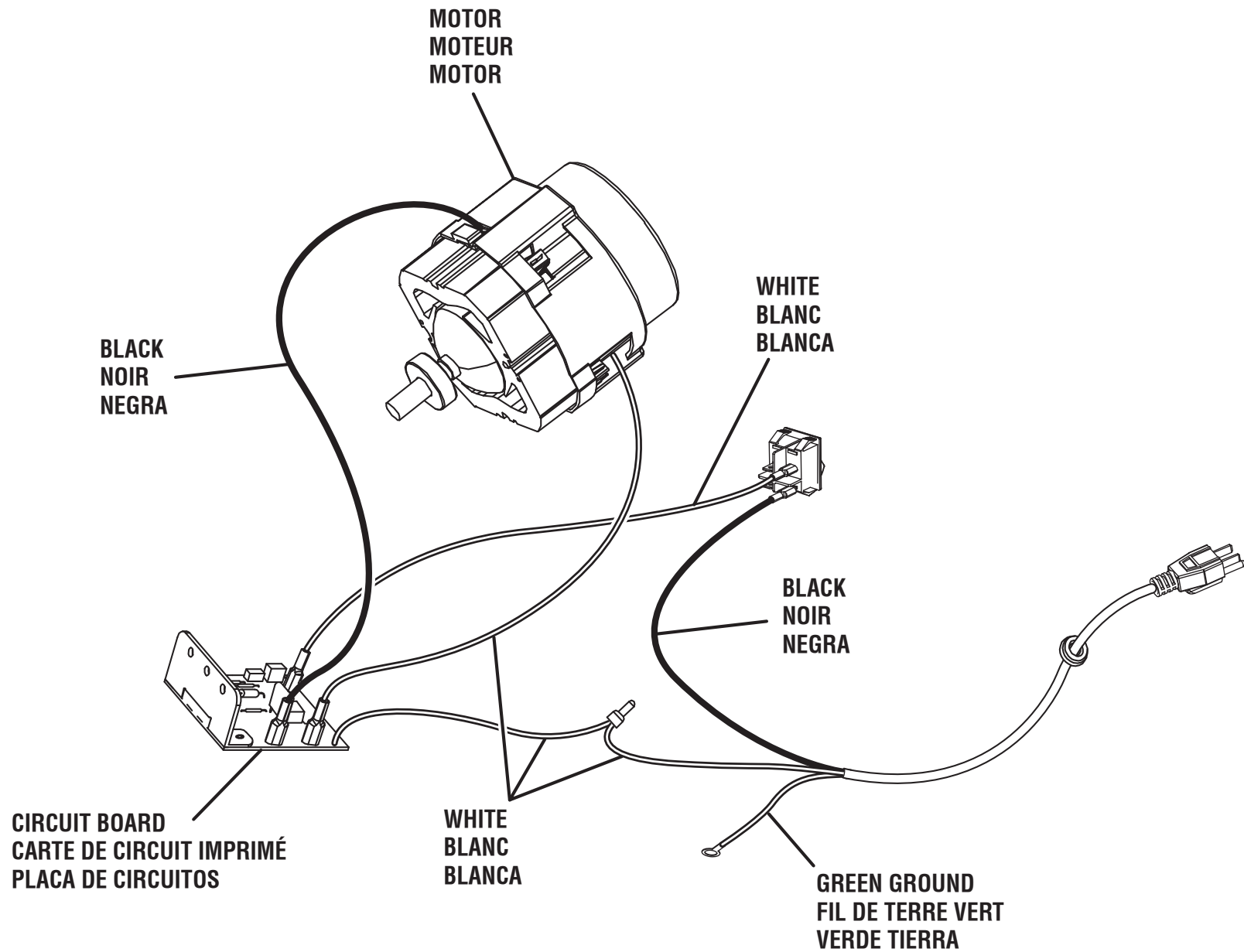

WIRING DIAGRAM / SCHÉMA DE CÂBLAGE / DIAGRAMA DE CABLEADO