

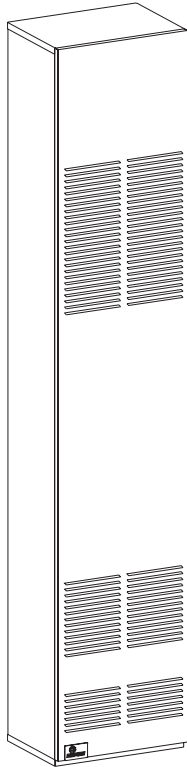

INSTALLATION INSTRUCTIONS AND OWNER'S MANUAL



FAN TYPE DIRECT VENT WALL FURNACE

MODEL
DVC-35T-1
DVC-35IPT-1



EFFECTIVE DATE
JANUARY 2007

Installer: Leave this manual with the appliance.

Consumer: Retain this manual for future reference.

This appliance may be installed in an aftermarket, permanently located, manufactured home (USA only) or mobile home, where not prohibited by state or local codes.

This appliance is only for use with the type of gas indicated on the rating plate. This appliance is not convertible for use with other gases, unless a certified kit is used.

WARNING: If not installed, operated and maintained in accordance with the manufacturer's instructions, this product could expose you to substances in fuel or from fuel combustion which can cause death or serious illness.

WARNING: If the information in these instructions are not followed exactly, a fire or explosion may result causing property damage, personal injury or loss of life.

- Do not store or use gasoline or other flammable vapors and liquids in the vicinity of this or any other appliance.
- **WHAT TO DO IF YOU SMELL GAS**
 - Do not try to light any appliance.
 - Do not touch any electrical switch; do not use any phone in your building.
 - Immediately call your gas supplier from a neighbor's phone. Follow the gas supplier's instructions.
 - If you cannot reach your gas supplier, call the fire department.
- Installation and service must be performed by a qualified installer, service agency or the gas supplier.

TABLE OF CONTENTS

SECTION	PAGE
Important Safety Information	3
Safety Information for Users of LP Gas	4
Requirements for Massachusetts.....	5
Introduction.....	6
Specifications	6
Gas Supply	7-8
Clearances	8
Installation Instructions.....	9-11
DVC-35T Standing Pilot Lighting Instructions	12
DVC-35IPT Intermittent Pilot Lighting Instructions	13
Pilot Flame Characteristics	14
Main Burner Flame Characteristics	15
Wiring	15-16
Service and Maintenance Suggestions.....	17
DVC-35IPT Intermittent Pilot Sequence of Operation.....	18
DVC-35IPT Intermittent Pilot System Troubleshooting Sequence	19
How to Order Repair Parts.....	20
Parts List	20
Parts View	21
Service Notes	22-23

IMPORTANT SAFETY INFORMATION

THIS IS A HEATING APPLIANCE

DO NOT OPERATE THIS APPLIANCE WITHOUT FRONT PANEL INSTALLED.

- Due to high temperatures the appliance should be located out of traffic and away from furniture and draperies.
- Children and adults should be alerted to the hazards of high surface temperatures and should stay away to avoid burns or clothing ignition.
- Young children should be carefully supervised when they are in the same room as the appliance.
- Clothing or other flammable material should not be placed on or near the appliance.
- Any safety screen or guard removed for servicing an appliance must be replaced prior to operating the appliance.
- Keep burner and control compartment clean.
- Vent cap hot while furnace is in operation.
- Installation and repair should be done by a **QUALIFIED SERVICE PERSON**. The appliance should be inspected before use and at least annually by a qualified service person. More frequent cleaning may be required due to excessive lint from carpeting, bedding materials, etc. It is imperative that control compartments, burners and circulating air passageways of the appliance be kept clean.
- **DO NOT** put anything around the furnace that will obstruct the flow of combustion and ventilation air.
- **DO** keep the appliance area clear and free from combustible material, gasoline and other flammable vapors and liquids.
- **DO** examine venting system periodically and replace damaged parts.
- **DO** make a periodic visual check of pilot and burners. Clean and replace damaged parts.
- **CAUTION:** Pilot hole cover must be kept tightly closed during operation.
- **DO NOT** use this heater if any part has been under water. Immediately call a qualified service technician to inspect the heater and to replace any part of the control system and any gas control which has been under water.

- **IMPORTANT:** This furnace has a washable permanent type filter which should be cleaned at least once per year before the heating season. For dirty or high use areas more frequent cleaning is required.

VENT KIT INFORMATION

Attention: The DVC-35T and DVC-35IPT direct vent wall furnaces are provided with vent kit, DV4T-59-1 for wall depths of 5” to 9”. For wall depths greater than 9”, refer to Accessories, Page 6. Listed below are the vent kits.

Attention: The minimum wall depth for installation of a DVC-35T and DVC-35IPT **MUST BE 5”**. If the wall depth is less than 5” you can order DV-822, refer to Accessories, Page 6 or refer to Figure 10 and Figure 11 with accompanying text, Page 11.

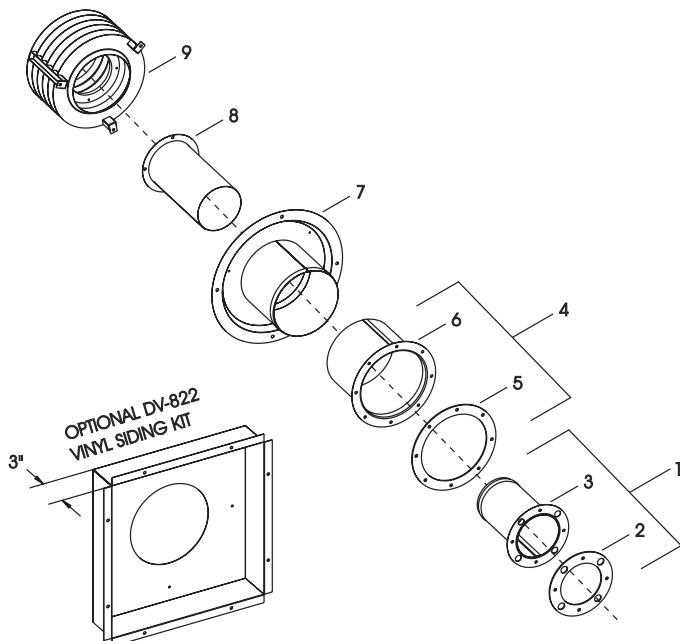

Vent Kits				
No.	Part	DV4T-59-1	DV4T-812-1	DV4T-1219-1
1	Outlet Tube - Inner	13057	13057	13058
2	Gasket - Outer Collar	M-177	M-177	M-177
3	Outlet Tube - Inner	13104	13104	13105
4	Inlet Tube - Inner	13062	13062	13063
5	Gasket - Inlet Collar	M-178	M-178	M-178
6	Inlet Tube - Inner	13106	13106	13107
7	Inlet Tube - Outer	13064	13065	13066
8	Outlet Tube - Outer	13059	13060	13061
9	Vent Cap	13053	13053	13053
	Hardware Kit	13078	13078	13078

SAFETY INFORMATION FOR USERS OF LP-GAS

Propane (LP-Gas) is a flammable gas which can cause fires and explosions. In its natural state, propane is odorless and colorless. You may not know all the following safety precautions which can protect both you and your family from an accident. Read them carefully now, then review them point

by point with the members of your household. Someday when there may not be a minute to lose, everyone's safety will depend on knowing exactly what to do. If, after reading the following information, you feel you still need more information, please contact your gas supplier.

LP-GAS WARNING ODOR

If a gas leak happens, you should be able to smell the gas because of the odorant put in the LP-Gas. That's your signal to go into immediate action!

- Do not operate electric switches, light matches, use your phone. Do not do anything that could ignite the gas.
- Get everyone out of the building, vehicle, trailer, or area. Do that IMMEDIATELY.
- Close all gas tank or cylinder supply valves.
- LP-Gas is heavier than air and may settle in low areas such as basements. When you have reason to suspect a gas leak, keep out of basements and other low areas. Stay out until firefighters declare them to be safe.
- Use your neighbor's phone and call a trained LP-Gas service person and the fire department. Even though you may not continue to smell gas, do not turn on the gas again. Do not re-enter the building, vehicle, trailer, or area.
- **Finally**, let the service man and firefighters check for escaped gas. Have them air out the area before you return. Properly trained LP-Gas service people should repair the leak, then check and relight the gas appliance for you.

NO ODOR DETECTED - ODOR FADE

Some people cannot smell well. Some people cannot smell the odor of the chemical put into the gas. You must find out if you can smell the odorant in propane. Smoking can decrease your ability to smell. Being around an odor for a time can affect your sensitivity or ability to detect that odor. Sometimes other odors in the area mask the gas odor. People may not smell the gas odor or their minds are on something else. Thinking about smelling a gas odor can make it easier to smell.

The odorant in LP-gas is colorless, and it can fade under some circumstances. For example, if there is an underground leak, the movement of the gas through soil can filter the odorant. Odorants

in LP-Gas also are subject to oxidation. This fading can occur if there is rust inside the storage tank or in iron gas pipes.

The odorant in escaped gas can adsorb or absorb onto or into walls, masonry and other materials and fabrics in a room. That will take some of the odorant out of the gas, reducing its odor intensity.

LP-Gas may stratify in a closed area, and the odor intensity could vary at different levels. Since it is heavier than air, there may be more odor at lower levels. Always be sensitive to the slightest gas odor. If you detect any odor, treat it as a serious leak. Immediately go into action as instructed earlier.

SOME POINTS TO REMEMBER

- **Learn to recognize the odor of LP-gas.** Your local LP-Gas Dealer can give you a "Scratch and Sniff" pamphlet. Use it to find out what the propane odor smells like. If you suspect that your LP-Gas has a weak or abnormal odor, call your LP-Gas Dealer.
- If you are not qualified, do not light pilot lights, perform service, or make adjustments to appliances on the LP-Gas system. If you are qualified, consciously think about the odor of LP-Gas prior to and while lighting pilot lights or performing service or making adjustments.
- Sometimes a basement or a closed-up house has a musty smell that can cover up the LP-Gas odor. Do not try to light pilot lights, perform service, or make adjustments in an area where the conditions are such that you may not detect the odor if there has been a leak of LP-Gas.
- Odor fade, due to oxidation by rust or adsorption on walls of new cylinders and tanks, is possible. Therefore, people should be particularly alert and careful when new tanks or cylinders are placed in service. Odor fade can occur in new tanks, or reinstalled old tanks, if they are filled and allowed to set too long before refilling. Cylinders and tanks which have been out of service for a time may develop internal rust which will cause odor fade. If such conditions are suspected to exist, a periodic sniff test of the gas is advisable. **If you have any question about the gas odor, call your LP-gas dealer. A periodic sniff test of the LP-gas is a good safety measure under any condition.**
- If, at any time, you do not smell the LP-Gas odorant and you think you should, assume you have a leak. Then take the same immediate action recommended above for the occasion when you do detect the odorized LP-Gas.
- If you experience a complete "gas out," (the container is under no vapor pressure), turn the tank valve off immediately. If the container valve is left on, the container may draw in some air through openings such as pilot light orifices. If this occurs, some new internal rusting could occur. If the valve is left open, then treat the container as a new tank. Always be sure your container is under vapor pressure by turning it off at the container before it goes completely empty or having it refilled before it is completely empty.

REQUIREMENTS FOR MASSACHUSETTS

For all side wall horizontally vented gas fueled equipment installed in every dwelling, building or structure used in whole or in part for residential purposes, including those owned or operated by the Commonwealth and where the side wall exhaust vent termination is less than seven (7) feet above finished grade in the area of the venting, including but not limited to decks and porches, the following requirements shall be satisfied:

1. **INSTALLATION OF CARBON MONOXIDE DETECTORS.** At the time of installation of the side wall horizontal vented gas fueled equipment, the installing plumber or gasfitter shall observe that a hard wired carbon monoxide detector with an alarm and battery back-up is installed on the floor level where the gas equipment is to be installed. In addition, the installing plumber or gasfitter shall observe that a battery operated or hard wired carbon monoxide detector with an alarm is installed on each additional level of the dwelling, building or structure served by the side wall horizontal vented gas fueled equipment. It shall be the responsibility of the property owner to secure the services of qualified licensed professionals for the installation of hard wired carbon monoxide detectors
 - a. In the event that the side wall horizontally vented gas fueled equipment is installed in a crawl space or an attic, the hard wired carbon monoxide detector with alarm and battery back-up may be installed on the next adjacent floor level.
 - b. In the event that the requirements of this subdivision can not be met at the time of completion of installation, the owner shall have a period of thirty (30) days to comply with the above requirements; provided, however, that during said thirty (30) day period, a battery operated carbon monoxide detector with an alarm shall be installed.
2. **APPROVED CARBON MONOXIDE DETECTORS.** Each carbon monoxide detector as required in accordance with the above provisions shall comply with NFPA 720 and be ANSI/UL 2034 listed and IAS certified.
3. **SIGNAGE.** A metal or plastic identification plate shall be permanently mounted to the exterior of the building at a minimum height of eight (8) feet above grade directly in line with the exhaust vent terminal for the horizontally vented gas fueled heating appliance or equipment. The sign shall read, in print size no less than one-half (1/2) inch in size, **“GAS VENT DIRECTLY BELOW. KEEP CLEAR OF ALL OBSTRUCTIONS”**.
4. **INSPECTION.** The state or local gas inspector of the side wall horizontally vented gas fueled equipment shall not approve the installation unless, upon inspection, the inspector observes carbon monoxide detectors and signage installed in accordance with the provisions of 248 CMR 5.08(2)(a) 1 through 4.
 - (b) **EXEMPTIONS:** The following equipment is exempt from 248 CMR 5.08(2)(a)1 through 4:
 1. The equipment listed in Chapter 10 entitled “Equipment Not Required To Be Vented” in the most current edition of NFPA 54 as adopted by the Board; and
 2. Product Approved side wall horizontally vented gas fueled equipment installed in a room or structure separate from the dwelling, building or structure used in whole or in part for residential purposes.
 - (c) **MANUFACTURER REQUIREMENTS - GAS EQUIPMENT VENTING SYSTEM PROVIDED.** When the manufacturer of Product Approved side wall horizontally vented gas equipment provides a venting system design or venting system components with the equipment, the instructions provided by the manufacturer for installation of the equipment and the venting system shall include:
 1. Detailed instructions for the installation of the venting system design or the venting system components; and
 2. A complete parts list for the venting system design or venting system.
 - (e) A copy of all installation instructions for all Product Approved side wall horizontally vented gas fueled equipment, all venting instructions, all parts lists for venting instructions, and/or all venting design instructions shall remain with the appliance or equipment at the completion of the installation.

INTRODUCTION

Introduction

Always consult your local Building Department regarding regulations, codes or ordinances which apply to the installation of a direct vent wall furnace.

Instructions to Installer

1. Installer must leave instruction manual with owner after installation.
2. Installer must have owner fill out and mail warranty card supplied with furnace.
3. Installer should show owner how to start and operate furnace and thermostat.

Warning:

Any change to this furnace or its control can be dangerous. This is a heating appliance and any panel, door or guard removed for servicing an appliance must be replaced prior to operating the appliance.

General Information

This furnace is design certified in accordance with American National Standard/CSA Standard Z21.86 and CSA 2.32 by the Canadian Standards Association, as a fan type direct vent wall furnace to be installed according to these instructions.

Any alteration of the original design, installed other than as shown in these instructions or use with a type of gas not shown on the rating plate is the responsibility of the person and company making the change.

Important

All correspondence should refer to complete Model No., Serial No. and type of gas.

Notice: During initial firing of this unit, its paint will bake out and smoke will occur. To prevent triggering of smoke alarms, ventilate the room in which the unit is installed.

Installation on Rugs and Tile

If this appliance is installed directly on carpeting, tile or other combustible material other than wood flooring the appliance shall be installed on a metal or wood panel extending the full width and depth of the appliance.

The base referred to above does not mean the fire-proof base as used on wood stoves. The protection is for rugs that are extremely thick and light colored tile.

Installation in Residential Garages

Gas utilization equipment in residential garages shall be installed so that all burners and burner ignition devices are located not less than 18" above the floor.

Such equipment shall be located, or protected, so it is not subject to physical damage by a moving vehicle.

Qualified Installing Agency

Installation and replacement of gas piping, gas utilization equipment or accessories and repair and servicing of equipment shall be performed only by a qualified agency. The term "qualified agency" means any individual, firm, corporation or company which either in person or through a representative is engaged in and is responsible for (a) the installation or replacement of gas piping or (b) the connection, installation, repair or servicing of equipment, who is experienced in such work, familiar with all precautions required and has complied with all the requirements of the authority having jurisdiction.

State of Massachusetts: The installation must be made by a licensed plumber or gas fitter in the Commonwealth of Massachusetts.

The installation must conform with local codes or, in the absence of local codes, with the *National Fuel Gas Code ANSI Z223.1/NFPA 54* Natural Gas and Propane Installation Code, CSA B149.1.*

**Available from the American National Standards Institute, Inc., 11 West 42nd St., New York, N.Y. 10036.*

High Altitudes

For altitudes/elevations above 2,000 feet, input ratings should be reduced at the rate of 4 percent for each 1,000 feet above sea level. For Canadian high altitude applications, this appliance is suitable for installation at elevations between 0 feet and 4,500 feet without change.

Piezo Pilot Ignitor Instructions

Depressing the red button completely causes a spark to occur at the pilot. This is a substitute for a match which requires opening the pilot hole cover.

To light the pilot, it is important that the electrode be 1/8" from the thermocouple. The spark must occur at the point the burner flame hits the thermocouple. The end of the electrode will be red hot with the pilot on.

On a new installation with air in the gas line, it is suggested that a match be used. The match will light the pilot faster than the piezo under this condition.

SPECIFICATIONS

Model	DVC-35T	DVC-35IPT
Input BTU/HR	35,000	35,000
Height	72 1/2"	72 1/2"
Width	14 1/8"	14 1/8"
Depth	10 3/8"	10 3/8"
Gas Inlet	1/2" Pipe	1/2" Pipe
CFM	275	275
Accessories		
SOR-1	Register, Side Outlet	
SOK-1	Side Outlet Kit, 10" (25.4cm) Boot Assembly with Register	
*DV-822	Vinyl Siding Vent Kit	
* DV-822, Vinyl siding vent kit, adds 3" to wall depth. You must include the three (3) additional inches for TOTAL wall depth when ordering a vent kit.		

GAS SUPPLY

Locating Gas Supply

The gas line can enter the unit either through the floor or outside wall. The gas line opening should be made at this time. Location of the opening will be determined by the position of floor joists and the valve and union used for servicing.

Recommended Gas Pipe Diameter

Pipe Length	Schedule 40 Pipe Inside Diameter		Tubing, Type L Outside Diameter	
	Nat.	L.P.	Nat.	L.P.
0-10 feet 0-3 meters	1/2"	3/8"	1/2"	3/8"
10-40 feet 4-12 meters	1/2"	1/2"	5/8"	1/2"
40-100 feet 13-30 meters	1/2"	1/2"	3/4"	1/2"
100-150 feet 31-46 meters	3/4"	1/2"	7/8"	3/4"

Note: Never use plastic pipe. Check to confirm whether your local codes allow copper tubing or galvanized.

Note: Since some municipalities have additional local codes, it is always best to consult your local authority and installation code.

The use of the following gas connectors is recommended:

- ANS Z21.24 Appliance Connectors of Corrugated Metal Tubing and Fittings
- ANS Z21.45 Assembled Flexible Appliance Connectors of Other Than All-Metal Construction

The above connectors may be used if acceptable by the authority having jurisdiction. The state of Massachusetts requires that a flexible appliance connector cannot exceed three feet in length.

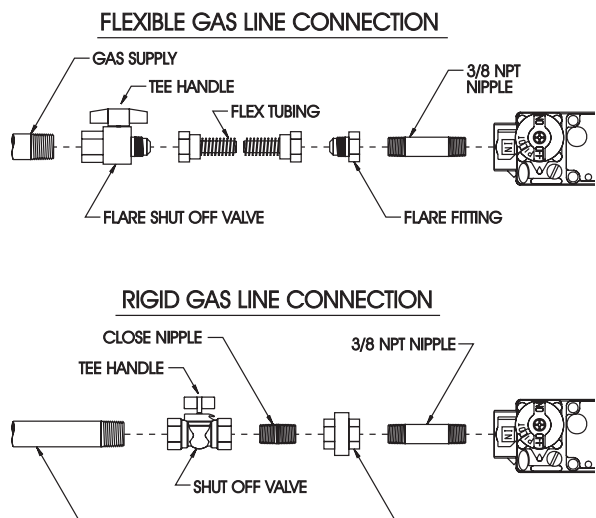

Figure 1

Consult the current National Fuel Gas Code, ANSI Z223.1 CAN/CGA-B149 (.1 or .2) installation code.

Installing a New Main Gas Cock

Each appliance should have its own manual gas cock.

A manual main gas cock should be located in the vicinity of the unit. Where none exists, or where its size or location is not adequate, contact your local authorized installer for installation or relocation.

Compounds used on threaded joints of gas piping shall be resistant to the action of liquefied petroleum gases. The gas lines must be checked for leaks by the installer. This should be done with a soap solution watching for bubbles on all exposed connections, and if unexposed, a pressure test should be made.

Never use an exposed flame to check for leaks. Appliance must be disconnected from piping at inlet of control valve and pipe capped or plugged for pressure test. Never pressure test with appliance connected; control valve will sustain damage!

A gas valve and ground joint union should be installed in the gas line upstream of the gas control to aid in servicing. It is required by the National Fuel Gas Code that a drip line be installed near the gas inlet. This should consist of a vertical length of pipe tee connected into the gas line that is capped on the bottom in which condensation and foreign particles may collect.

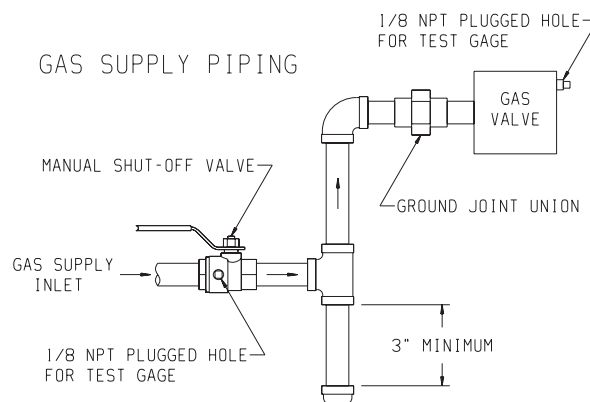

Figure 2

Method of Installing a Tee Fitting Sediment Trap

Pressure Testing of the Gas Supply System

1. To check the inlet pressure to the gas valve, a 1/8" N.P.T. plugged tapping, accessible for test gauge connection, must be placed immediately upstream of the gas supply connection to the appliance.
2. The appliance and its individual shutoff valve must be disconnected from the gas supply piping system during any pressure testing of that system at test pressures in excess of 1/2 psig (3.5 kPa).
3. The appliance must be isolated from the gas supply piping system by closing its individual manual shutoff valve during any pressure testing of the gas supply piping system at test pressures equal to or less than 1/2 psig (3.5 kPa).

Attention! If one of the above procedures results in pressures in excess of 1/2 psig (14" w.c.) (3.5 kPa) on the appliance gas valve, it will result in a hazardous condition.

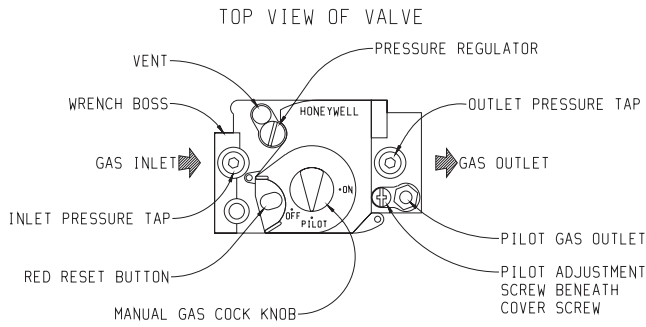

Figure 3

Checking Manifold Pressure

Both Propane and Natural gas valves have a built-in pressure regulator in the gas valve. Natural gas models will have a manifold

pressure of approximately 4.0" w.c. (.996kPa) for DVC-35T and 3.5" w.c. (.871kPa) for DVC-35IPT at the valve outlet with the inlet pressure to the valve from a minimum of 5.0" w.c. (1.245kPa) for the purpose of input adjustment to a maximum of 7.0" w.c. (1.743kPa). Propane gas models will have a manifold pressure approximately 10.0" w.c. (2.49kPa) at the valve outlet with the inlet pressure to the valve from a minimum of 11.0" w.c. (2.739kPa) for the purpose of input adjustment to a maximum of 13.0" w.c. (3.237kPa).

A 1/8" N.P.T. plugged tapping, accessible for test gauge connection, is located on the outlet side of the gas control.

The built-in regulator comes on at approximately 1/4th pressure and full on in 10 seconds.

CLEARANCES

Clearances

1. In selecting a location for installation, it is necessary to provide adequate accessibility clearances for servicing and proper installation. A front clearance of 36" is recommended. Do not block outlet or inlet air openings on the front grill.
2. **The DV4T-59-1, 5" to 9" wall depth is the standard vent kit provided with the DVC-35T or DVC-35IPT. See Accessories Page 6 to order vent kits for wall depths of 8" to 12" or 12" to 19". The use of tubes not supplied by the manufacturer results in unsatisfactory performance.**
3. The DVC-35T and DVC-35IPT can be attached to the wall or recessed into the wall up to 9 1/2" in depth but the minimum 5" vent/air intake system wall depth must be maintained. Example: If furnace is recessed into the wall at a depth of 9 1/2", the minimum wall depth behind the furnace must be 5".
4. The wall in which the furnace is recessed has (0) zero clearance to the furnace sides and top.
5. When using side discharge registers, SOR-1 or SOK-1, the furnace cannot be recessed into the wall.
6. Clearance to sidewall or combustible material is 4".
7. Ceiling clearance is 4".
8. Floor and rear wall clearance is (0) zero inches.
9. Clearance of 18" is required to sidewall or combustible material when flush mounted SOR-1, side outlet register is used.
10. The minimum distance from the center of the vent cap to the nearest outside corner or obstruction is 12".

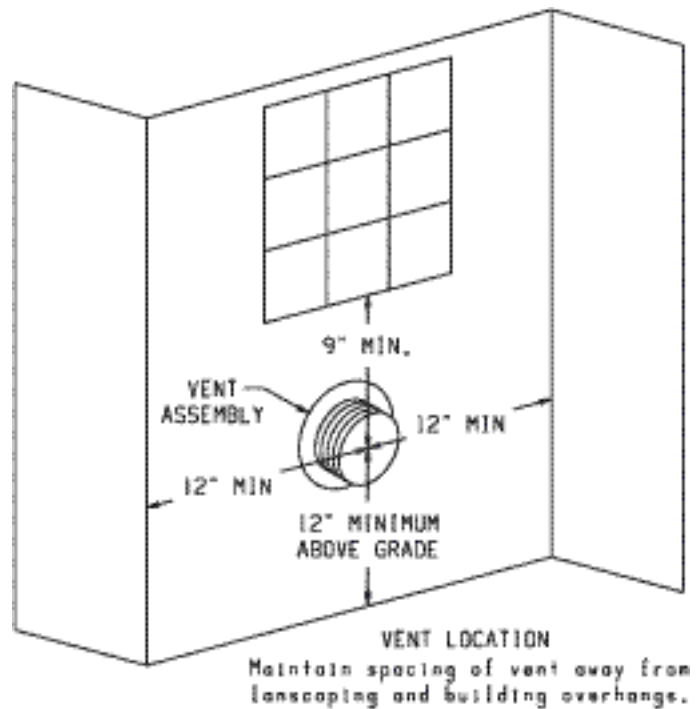

Figure 4

The vent terminal of this direct vent appliance shall be located at least 9" from any opening through which flue gases could enter a building. The bottom of the vent terminal and the air intake shall be located at least 12" above grade. See vent location, Figure 4.

WARNING: The nearest point of the vent cap should be a minimum horizontal distant of six (6) feet from any pressure regulator. In case of regulator malfunction, the six (6) feet distance will reduce the chance of gas entering the vent cap.

INSTALLATION INSTRUCTIONS

Locating Wall Opening

The furnace is to be located on an outside wall. Locate wall studs so that wall opening will be located between wall studs. The furnace is 14 1/8" in width and can be recessed between standard 16" on center wall studs. The wall opening required as shown in Figure 5 is a diameter of 7 1/2".

A template is provided in furnace carton for positioning furnace on the wall. Also, refer to Figure 5 and Figure 7 for positioning the furnace on wall and for locating gas line connection.

Installing Optional Side Outlets

Side outlet register, SOR-1 may be installed on one or both sides of the furnace at the required clearances of 18" to adjacent wall or combustible material as shown in Figure 6.

1. Turn "OFF" all electric power to the furnace.
2. Remove the front panel from the furnace.
3. Remove the two (2) 8 x 3/8" screws that attach the inner shield cover plate to the inner shield.
4. Scribe a line between the four dimples on the outer casing side to form a square.
5. Drill a pilot hole within the scribed square on the outer casing. Remove the sheet metal within the scribed square with a tin snips or comparable tool. **Attention!** Do not cut the electrical wires located between the outer casing and the inner shield.
6. Insert the 5" x 5" inner boot through the outer casing. Align the clearance holes on the inner boot with the screw holes on the inner shield. Attach inner boot to inner shield with two (2) 8 x 3/8" screws removed in Step 3.
7. Place the register over the 5 1/2" square opening with the louvers set for the desired direction and mark the mounting holes using the register as a template.
8. Drill two (2) 1/8" diameter holes in cabinet side and attach the register with two (2) 10 x 1" provided screws.
9. Installation of SOR-1 is completed.

Side outlet kit, SOK-1, 10" boot assembly with register, for warm air discharge into an adjoining room may be installed on either side of the furnace at the required clearance of 4" to adjacent wall as shown in Figure 6.

To install SOK-1, please use Steps 1 through 5 in the SOR-1 instructions for DVC-35T furnaces. Now, use the following Steps to complete installation of the SOK-1.

1. Using the inner and outer boots as hole templates, mark and drill four (4) 1/8" (3mm) diameter holes in the inner shield and four (4) 1/8" (3mm) diameter holes in the cabinet side.
2. Locate and cut a 6 3/4" square opening through wall.
3. Attach furnace to wall (see **Attaching Furnace to Wall**).
4. With furnace in place, after checking alignment of side outlet opening in wall and furnace, place the 9 3/8" x 9 3/8" side outlet wall plate over outer boot, pass the outer boot through the wall and attach side wall plate to furnace side of wall with two (2) 10 x 1 1/2" provided screws.
5. Attach outer boot to the cabinet side with four (4) 8 x 1/4" provided screws.
6. Position and attach inner boot to inner shield with four (4) 8 x 1/4" provided screws.
7. Place the register over the 6 3/4" square opening with the louvers positioned for the desired discharge direction and mark the mounting holes using the register as a template.

8. Drill two (2) 1/8" diameter holes in the wall and attach the register with two (2) 10 x 1 1/2" provided screws.
9. Installation of SOK-1 is completed.

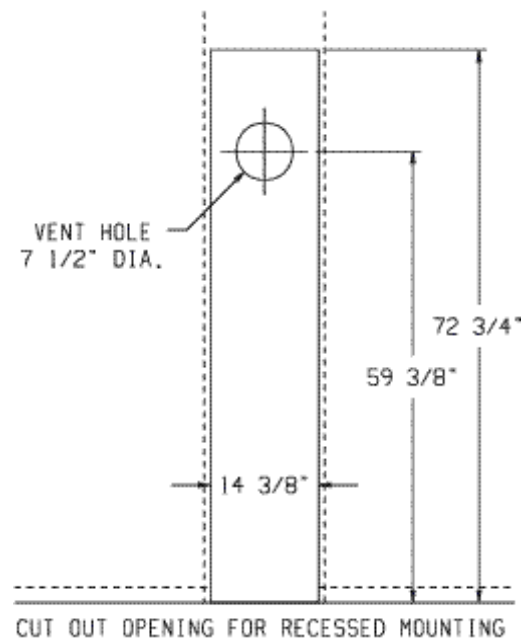

Figure 5

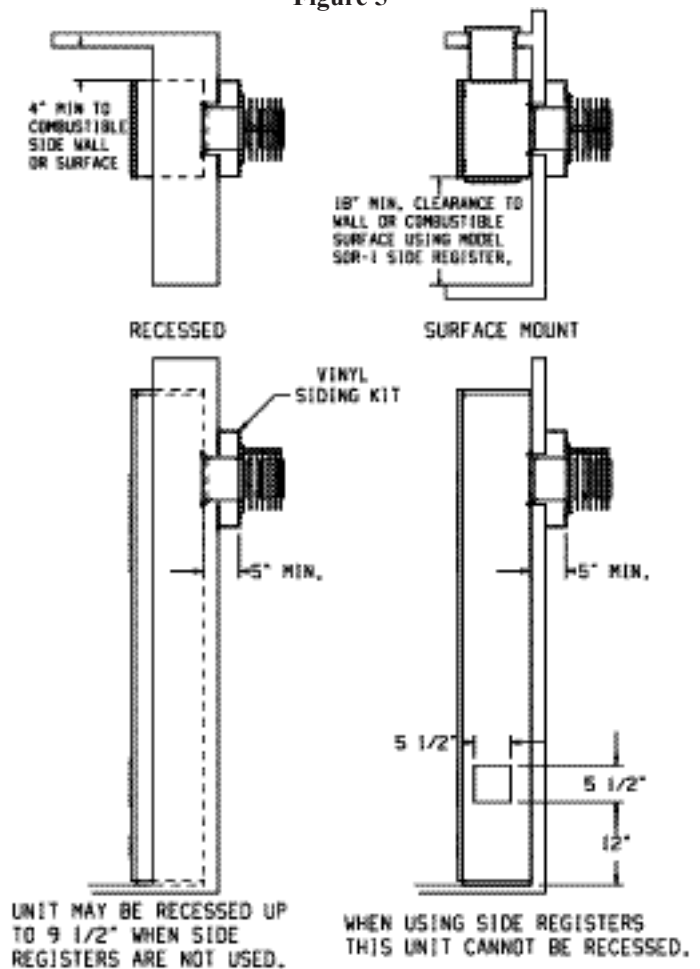

Figure 6

Locating Electric Supply

A 7/8" diameter knockout is provided at the bottom of the left and right side panels. A three-prong (grounding) plug assembly is located within the control compartment (bottom) of the furnace. Please remove 7/8" knockout from appropriate side panel when routing plug assembly to an electrical outlet. Unit can be hard wired when recessed. Remove the 3 prong plug assembly and terminate inside the unit junction box.

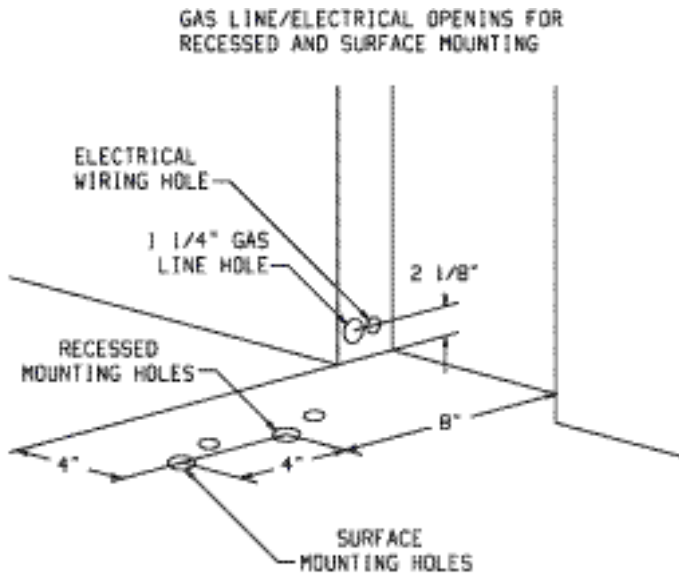

Figure 7

Installation of Three-prong (Grounding) Plug Assembly

1. Disconnect nylon cap on 3' plug assembly from nylon plug on wiring harness. Remove 3' plug assembly from control compartment (bottom) of the furnace.
2. Remove 7/8" knockout from appropriate side panel.
3. Insert nylon cap on 3' plug assembly into the 7/8" hole in the side panel.
4. Connect nylon cap on 3' plug assembly to nylon plug on the wiring harness.
5. Place 7/8" strain relief bushing around the cord of the 3' plug assembly. Insert 7/8" strain relief bushing into the 7/8" hole in the side panel.

Attention! The 7/8" strain relief bushing is located within the same envelope as the Installation Instructions and Owner's Manual.

Attaching Furnace to Wall

Place collar on four inch flue tube against outlet box. Align clearance holes on collar with screw holes in outlet box. Attach four inch flue tube to outlet box with four (4) 10 x 1/2" screws.

Attention: Do not overtighten screws because outlet box must be able to move as flue tube expands and contracts.

Place collar on six inch air tube against air drop. Align clearance holes on collar with screw holes in air drop. Attach six inch air tube to air drop with eight (8) 10 x 1/2" screws.

Refer to Figure 5 for the location of the 7 1/2" diameter wall opening for the furnace. After the wall opening has been located and cut, position flue outlet on furnace in center of wall opening. Insert tubes through wall opening. When attaching furnace to the wall remove that portion of baseboard and molding on the wall which is behind the furnace. Attach furnace to wall, at the outer casing top,

with two (2) plastic expansion anchors provided and to floor, at the outer casing bottom, with two (2) 10 x 1 1/2" screws provided.

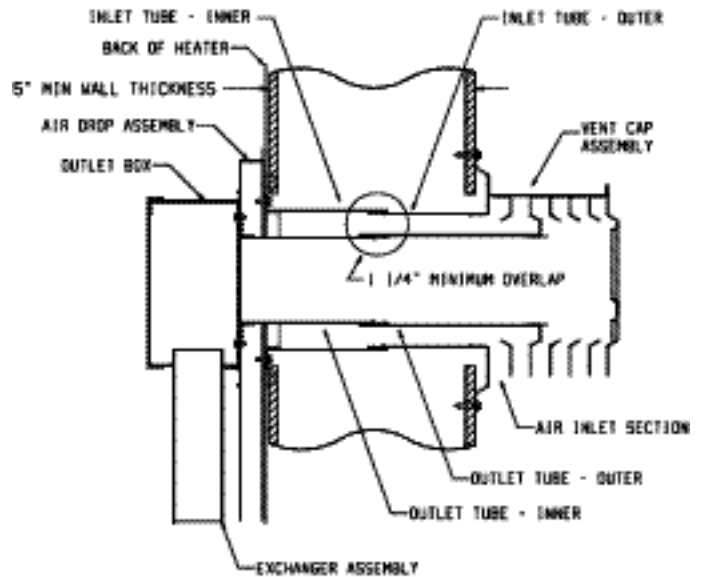

Figure 8

Using Plastic Expansion Anchors

1. After locating mounting holes, drill two (2) 5/16" diameter holes into the wall.
2. Insert two (2) plastic expansion anchors provided into the holes.
3. Tighten two (2) 10 x 1" screws provided into the plastic expansion anchors. (See Figure 9)

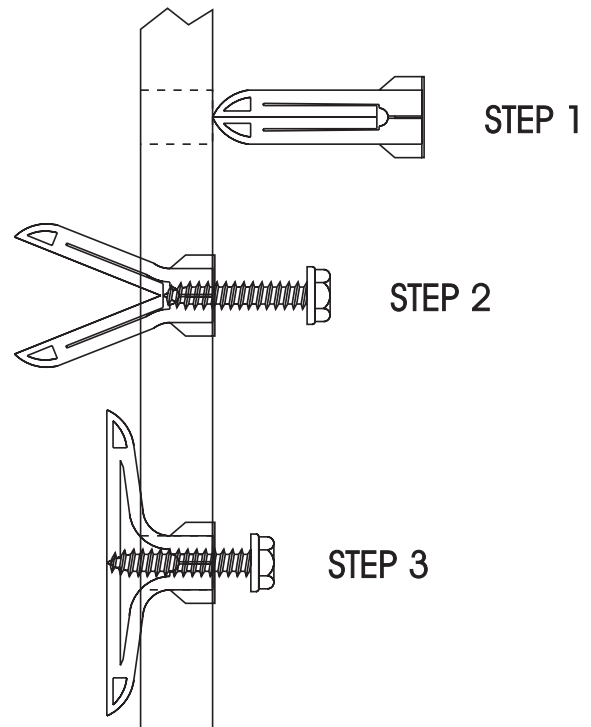

Figure 9

Attention! The screw holes on the outer casing bottom are off-set the floor approximately 3/8". Do not over-tighten screws and distort the off-set on the outer casing bottom. Distortion of the outer casing bottom will not allow the lower front panel to be attached to the furnace.

INSTALLATION INSTRUCTIONS (continued)

Installing Vent Assembly

Attention: DO NOT attempt to cut vent tubes. When you order appropriate vent kit for measured wall depth the vent tubes will fit together.

1. Place provided caulking beneath the collar of the outside mounting plate. Use additional caulking to correct uneven wall surface, such as clapboard.
2. Insert six inch air tube on outside mounting plate **INTO** six inch air tube attached to air drop. Place four inch flue tube on vent cap **OVER** four inch flue tube attached to outlet box. Position the outside mounting plate so that six inch air tube has a slight downward slope to the outside. **The downward slope is necessary to prevent the entry of rainwater.** Attach outside mounting plate to exterior wall with four (4) 10 x 1 1/2" screws.
3. Installation is completed.

Reassembly And Resealing Vent-Air Intake System

When vent-air intake system is removed for servicing the furnace, the following steps will assure proper reassembly and resealing of the vent-air intake assembly.

1. Remove old caulking beneath the collar of the outside mounting plate. Apply new caulking beneath the collar of the outside mounting plate. Use additional caulking to correct uneven wall surface, such as clapboard.
2. Insert six inch air tube on outside mounting plate **INTO** six inch air tube attached to air drop. Position the outside mounting plate so that six inch air tube has a slight downward slope to the outside. **The downward slope is necessary to prevent the entry of rainwater.** Attach outside mounting plate to exterior wall with four (4) 10 x 1 1/2" screws.
3. Place four inch flue tube on vent cap **OVER** four inch flue tube attached to outlet box. Attach vent cap to outside mounting plate with three (3) 10 x 1/2" screws.
4. Reassembly and resealing vent-air intake system is completed.

Installing a Vent Near a Window Ledge, Other Type of Projection or on Siding (vinyl, aluminum, etc.)

Direct vent furnaces are designed to be installed on a uniform outside wall. When the wind comes from any angle (up, down or from either side), it must hit the vent cap equally over both the air inlet and the flue outlet portions of the vent. Any wall projection, such as a door or window casing, which disturbs the wind on one side of the air inlet section will result in back pressure on the flue section smothering the flame and eventual pilot outage.

When the vent cap is to be installed on siding or it appears that a projection within 6" of any side of the air inlet section could shield the air inlet section, the entire vent should be supported away from the wall at least the distance of the projection. 2" x 4" framing whose outside dimensions match the overall dimensions of the mounting plate is recommended. The 2" x 4" framing protects siding from possible warpage or discoloration. All joints can then be sealed and painted. The wall depth plus the additional depth of the 2" x 4" framing should not exceed a total depth of 14" for DVC-35T. (See Figure 10)

Vinyl siding vent kit, DV-822, is available from Empire Comfort Systems, Inc. The depth is 3", which enables the vent cap to be extended away from siding or projections. The wall depth plus the additional 3" depth of the vinyl siding vent cap extension should not exceed a total depth of 19" for DVC-35T. (See Figure 11)

Warning: When vinyl siding vent kit, DV-822 or 2" x 4" framing is added to an existing installation (furnace is installed) do not attempt to add sections of pipe to the flue outlet tube or air inlet tube. An air tight seal is required for both tubes. Refer to Parts List, page 16 to order tubes.

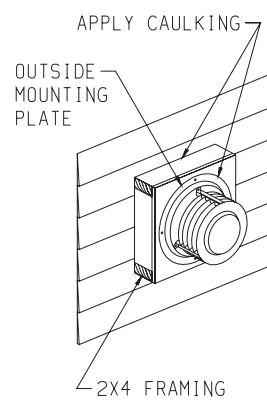

Figure 10

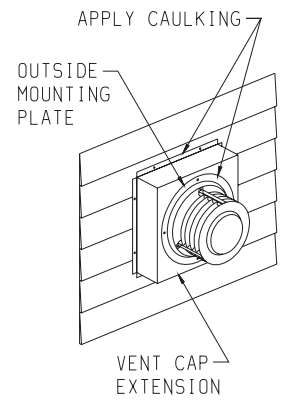

Figure 11

DVC-35T STANDING PILOT LIGHTING INSTRUCTIONS

FOR YOUR SAFETY READ BEFORE LIGHTING

WARNING: If you do not follow these instructions exactly, a fire or explosion may result causing property damage, personal injury or loss of life.

- A. This appliance has a pilot which must be lighted by hand. When lighting the pilot, follow these instructions exactly.
- B. **BEFORE LIGHTING** smell all around the appliance area for gas. Be sure to smell next to the floor because some gas is heavier than air and will settle on the floor.
WHAT TO DO IF YOU SMELL GAS
 - Do not try to light any appliance.
 - Do not touch any electrical switch; do not use any phone in your building.
 - Immediately call your gas supplier from a neighbor's phone. Follow the gas supplier's instructions.
- C. If you cannot reach your gas supplier, call the fire department.
- D. Use only your hand to push in or turn the gas control knob. Never use tools. If the knob will not push in or turn by hand, don't try to repair it; call a qualified service technician. Force or attempted repair may result in a fire or explosion.
- D. Do not use this appliance if any part has been under water. Immediately call a qualified service technician to inspect the appliance and to replace any part of the control system and any gas control which has been under water.

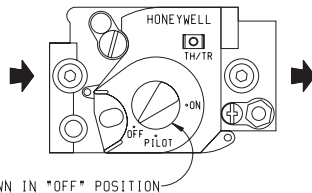

LIGHTING INSTRUCTIONS

1. **STOP!** Read the safety information above.
2. Set the thermostat to lowest setting.
3. Turn off all electric power to the appliance.
4. Remove control access panel (lower front panel).

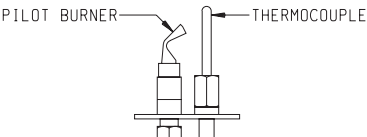

5. Turn gas control knob clockwise  to "OFF."
6. Wait ten (10) minutes to clear out any gas. Then smell for gas, including near the floor. If you smell gas, **STOP!** Follow "B" in the safety information above. If you don't smell gas, go to the next step.
7. Remove the pilot access cover located on the combustion chamber.

8. Find pilot - follow metal tube from gas

control. The pilot is located between the two burner tubes behind the pilot access cover.

9. Turn gas control knob counterclockwise  to "PILOT."
10. Push and hold red reset button down completely and repeatedly push the ignitor button until the pilot burner is lit. Pilot may also be lit with a match. Continue to hold the red reset button down for about one (1) minute after the pilot is lit. Release button and it will pop back up. Pilot should remain lit. If it goes out, repeat steps 5 through 10.
 - If button does not pop up when released, stop and immediately call a qualified service technician or gas supplier.
 - If the pilot will not stay lit after several tries, turn the gas control knob to "OFF" and call your service technician or gas supplier.
11. Replace pilot access cover.
12. Turn gas control knob counterclockwise  to "ON."
13. Replace control access panel (lower front panel).
14. Turn on all electric power to the appliance.
15. Set thermostat to desired setting.

TO TURN OFF GAS TO APPLIANCE

1. Set the thermostat to lowest setting.
2. Turn off all electric power to appliance if service is to be performed.
3. Remove control access panel (lower front panel).
4. Push in gas control knob slightly and turn clockwise  to "OFF." Do not force.
5. Replace control access panel (lower front panel).

DVC-35IPT INTERMITTENT PILOT LIGHTING INSTRUCTIONS

FOR YOUR SAFETY READ BEFORE OPERATING

WARNING: If you do not follow these instructions exactly, a fire or explosion may result causing property damage, personal injury or loss of life.

- A. This appliance is equipped with an ignition device which automatically lights the pilot. Do not try to light the pilot by hand.
- B. **BEFORE OPERATING** smell all around the appliance area for gas. Be sure to smell next to the floor because some gas is heavier than air and will settle on the floor.
- WHAT TO DO IF YOU SMELL GAS**
- Do not try to light any appliance.
 - Do not touch any electrical switch; do not use any phone in your building.
 - Immediately call your gas supplier from a neighbor's phone. Follow the gas supplier's instructions.
- If you cannot reach your gas supplier, call the fire department.
- C. Use only your hand to slide the gas control knob. Never use tools. Force or attempted repair may result in a fire or explosion.
- D. Do not use this appliance if any part has been under water. Immediately call a qualified service technician to inspect the appliance and to replace any part of the control system and any gas control which has been under water.

OPERATING INSTRUCTIONS

1. **STOP!** Read the safety information above.
2. Set the thermostat to lowest setting.
3. Turn off all electric power to the appliance.
4. This appliance is equipped with an ignition device which automatically lights the pilot. Do not try to light the pilot by hand.
5. Remove front panel door.
6. Slide gas control switch to "OFF."
7. Wait ten (10) minutes to clear out any gas. Then smell for gas, including near the floor. If you smell gas, **STOP!** Follow "B" in the safety information above. If you don't smell gas, go to the next step.
8. Slide gas control switch to "ON".
9. Replace front panel door.
10. Turn on all electric power to the appliance.
11. Set thermostat to desired setting.
12. If the appliance will not operate, follow the instructions "TO TURN OFF GAS TO APPLIANCE" and call your service technician or gas supplier.

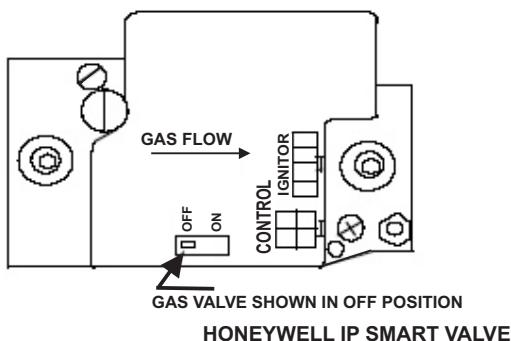

TO TURN OFF GAS TO APPLIANCE

1. Set the thermostat to lowest setting.
2. Turn off all electric power to the appliance if service is to be performed.
3. Remove front panel door.
4. Slide gas control switch to "OFF."
5. Replace front panel door.

PILOT FLAME CHARACTERISTICS

The correct pilot flame (Figure 12) will be blue, extending past the thermocouple. The flame will surround the thermocouple just below the tip.

Natural gas pilots require adjusting when the inlet gas pressure is above 5" w.c. (1.245kPa). Remove the pilot cover screw on the control valve (Figure 3), and turn the adjustment screw clockwise to reduce flame. Replace pilot cover screw to eliminate gas leaking at that control valve opening.

LP gas (propane) will not require adjustment.

After use, cleaning may be required for the proper flame.

IP-Model Pilot



This heater is using a Honeywell "Smart Valve" system for intermittent pilot ignition.

On a call for heat by the thermostat this control turns on a 24 volt mini hot surface ignitor which lights a pilot that in turn lights the main burner. The gas valve used in this system is a step opening which opens at a lower pressure for ignition and then steps to a full inlet pressure of 4" pressure on Natural gas and 10" pressure on LP gas.

Pilot Flame Adjustment

The pilot flame should envelop 3/8 to 1/2 inch (10 to 13mm) of the tip of the flame rod. See Figure 12.

To adjust:

1. Remove the pilot adjustment cover screw.
2. Turn the inner adjustment screw clockwise  to decrease or counterclockwise  to increase pilot flame. Pilot adjustment is shipped at full flow rate. Turn the inner adjustment screw clockwise  if the inlet pressure is too high.
3. Replace the cover screw after the adjustment to prevent gas leakage.

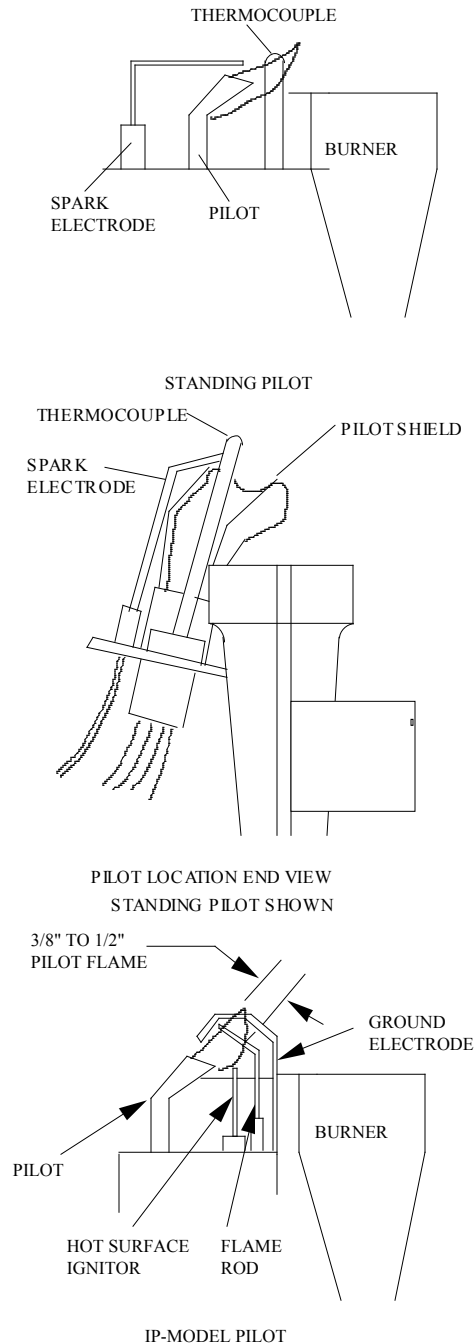

Figure 12

MAIN BURNER FLAME CHARACTERISTICS

The correct flame will be a short, blue inner flame with a much larger, light blue, outer flame. The burner does not have a primary air adjustment. The flame will be correct if the factory-set pressure and orifice opening are used. After the furnace has been operating, the burner ports may be blocked by foreign matter carried in by combustion air. Therefore, cleaning of the burner may be needed for proper flame.

To clean burner port disconnect the gas supply to the valve, and remove the screws fastening the burner door. After removing the burner door from the burner box, remove each main burner. Pilot mounting bracket will need to be unscrewed and moved out of the way to remove all burners. Burners can be blown out using compressed air or by blowing through them. Be sure there is no lint or foreign debris blocking the burner ports. Reassemble using the same screws earlier removed and locate pilot in the same position as before and noted above.

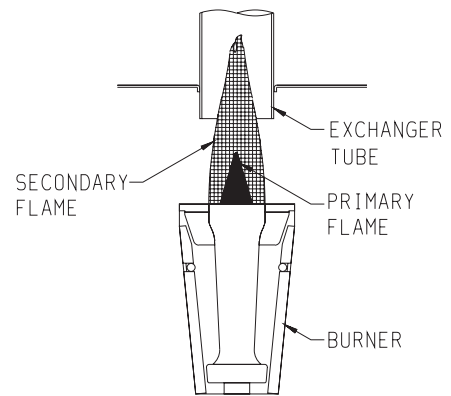

Figure 13

WIRING

The appliance, when installed, must be electrically grounded in accordance with local codes or, in the absence of local codes, with the *National Electrical Code, ANSI/NFPA 70* or *Canadian Electrical Code, CSA C22.1*, if an external electrical source is utilized. **This appliance is equipped with a three-prong [grounding] plug for your protection against shock hazard and should be plugged directly into a properly grounded three-prong receptacle. Do not cut or remove the grounding prong from this plug.** For an ungrounded receptacle, an adapter, which has two prongs and a wire for grounding, can be purchased, plugged into the ungrounded receptacle and its wire connected to the receptacle mounting screw. With this wire completing the ground, the appliance cord plug can be plugged into the adapter and be electrically grounded. A 7/8" hole is provided in the junction box for use with a conduit connector if local codes require this type of protection.

Thermostat Installation

The thermostat should be installed in the same room as the furnace 4' to 5' above the floor and away from another heat source (cooking stove, hot water heater, etc.) including walls and doorways with a heat source in an adjoining room. **Do Not Install Thermostat on Outside Wall.**

CAUTION: Label all wires prior to disconnection when servicing controls. Wiring errors can cause improper and dangerous operation. Verify proper operation after servicing.

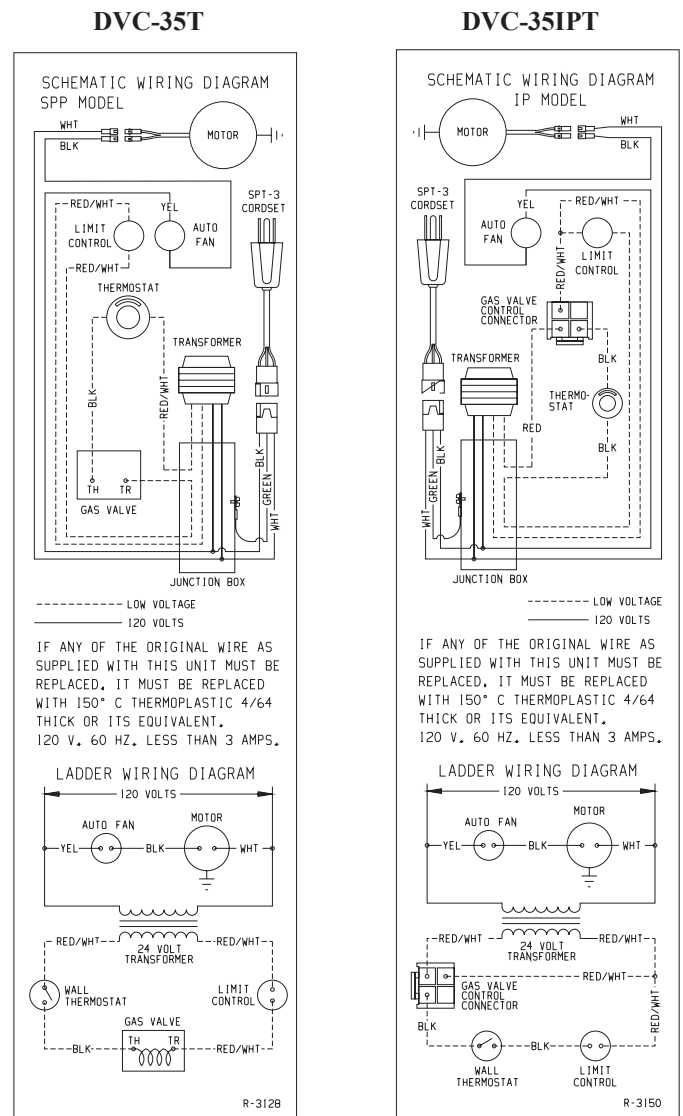

Figure 14

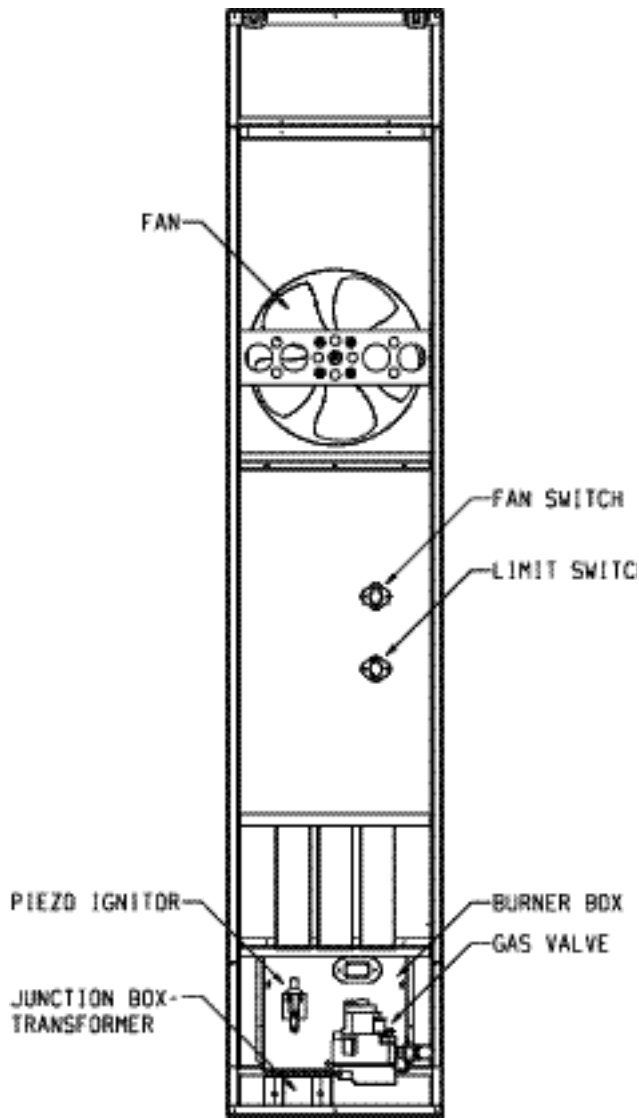

Figure 15

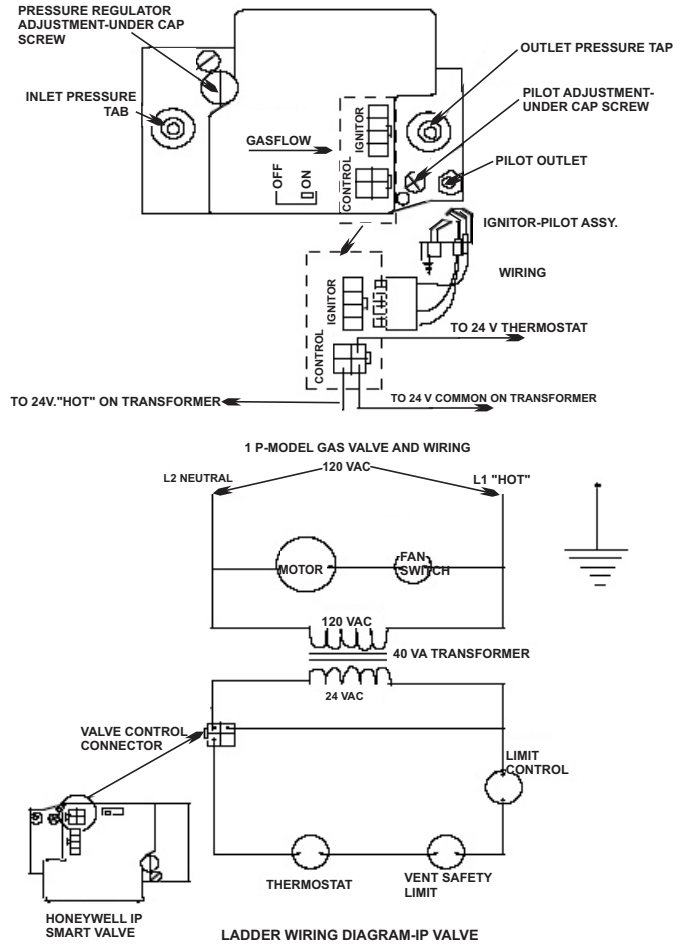

Figure 16

SERVICE AND MAINTENANCE SUGGESTIONS

GENERAL: All furnaces have been fire-tested to check for proper operation. This includes, main burner flame, pilot flame, fan operation, fan control, limit control and automatic valve operation. If the furnace fails to function on initial installation, it is advisable to re-check the following:

1. 115 volts to the junction box.
2. Inlet gas pressure.
3. The 24 volt system.
4. Type of gas being used and that shown on the rating label.

The Service Department at Empire Comfort Systems, Inc. may be contacted to assist in servicing furnace or a call a qualified serviceman.

Standing Pilot Model

Servicing the Pilot and Main Burners, Pilot Orifice, Thermocouple, and Main Burner Orifices: Disconnect the gas supply at the inlet to the control valve. Then remove the burner door to gain access to the above listed components.

Spark Igniter Does Not Light Pilot: With air in the gas line, such as when the furnace is first installed or was off all summer, the pilot flame may be too lean to ignite on the first few trials. Turn the control valve knob to pilot position and depress the red reset button. Holding the button down continually to bleed the line;

1. Use lighter rod to light pilot with a match.
2. Use the piezo ignitor at 30 second intervals until it lights.

If Electrode Does Not Produce Spark:

1. Check wire connections.
2. Check gap for pilot burner to the electrode tip. Should be between 1/8" and 3/16". Electrode wire and tip must be more than 1/4" away from all other metal components.

If Pilot Does Not Light By Any Means:

1. Check valve knob for being in the "Pilot" position.
2. Check pilot adjustment for being full open (counterclockwise to open).
3. If gas is available in the supply tubing, the pilot orifice and/or pilot burner is probably restricted by a spider web. Clean pilot assembly and relight.

If Pilot Does Not Remain On After Releasing Knob:

1. Follow instructions and hold button down longer and harder.
2. Determine if pilot flame extends past thermocouple; if not, adjust input or clean pilot burner.
3. Replace thermocouple if millivolts read less than 15 millivolts.

Pilot Outage During Normal Operation:

1. Check air inlet tube for a good fit.
2. Check burner door and pilot hole cover for tight seal.
3. Check input by manifold pressure gauge or gas meter.

Main Gas Valve Does Not Open When Thermostat Is Turned To On:

1. Check for 24 volts to valve by removing one wire and touching to the **SAME TERMINAL** it was on. Terminal should have a light spark. **DO NOT SHORT ACROSS TERMINALS, AS IT WILL BURN OUT THE WALL THERMOSTAT.**
2. Thermostat wires at the wall may be shorted, so check for a faulty thermostat.
3. To check for line voltage to furnace, remove front panel and short across two-terminal fan control to allow fan to operate. (Figure 15)

Cleaning Combustion (Exchanger) Assembly

A QUALIFIED SERVICE PERSON should remove the combustion (exchanger) assembly and flue baffles. Apply air pressure to the inside of the combustion (exchanger) assembly and flue baffles in order to clear all passageways.

Oiling the Motor

The fan motor should be cleaned and oiled once each heating season. Oil holes are located on the top at each end of the motor. Use a few drops of #10 motor oil. To clean the motor, blow air through its ventilation openings with a vacuum cleaner or low pressure air source.

DVC-35IPT INTERMITTENT PILOT SEQUENCE OF OPERATION

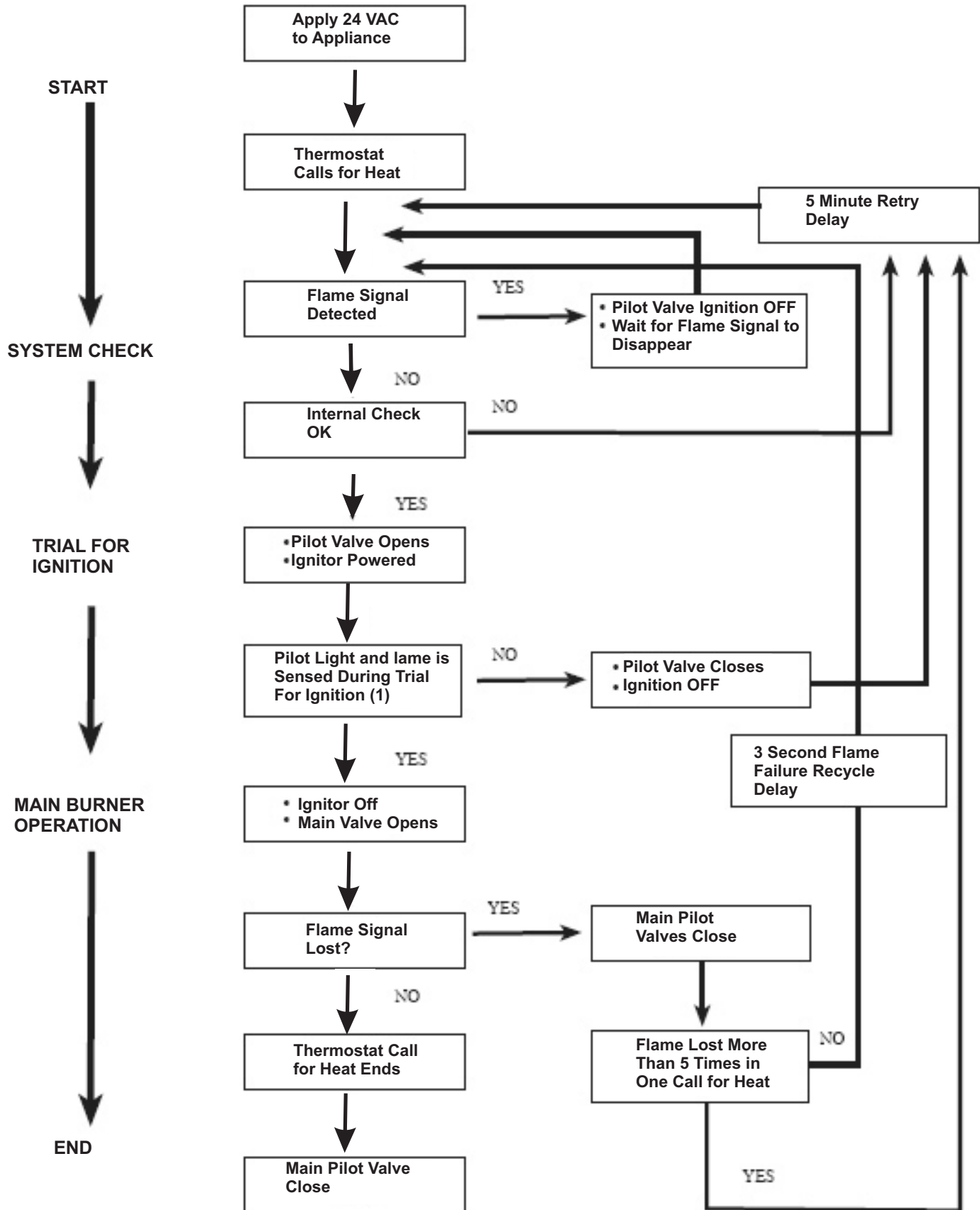

(1) Ignitor will turn OFF about 30 seconds into the trial for ignition if the pilot flame has not lit. It will turn back ON for the final 30 seconds of the 90 second trial for ignition. The pilot valve will be energized during the entire trial for ignition. This is normal operation for this gas ignition system.

DVC-35IPT INTERMITTENT PILOT SYSTEM TROUBLESHOOTING SEQUENCE

START

- Turn OFF Gas Supply
- Disconnect System Control Harness
- Set Thermostat to Call for Heat

Check for Proper Voltage at Control Harness (See Inset A -Voltage Should be 24V Between Thermostat and 24V Common, and 24V Between 24V Common and 24V Hot.)

NO

SmartValve™ System Troubleshooting Sequence
Note: Before Troubleshooting, Become Familiar with the Sequence of Operation

- CHECK
- Line Voltage Power
 - Low Voltage Transformer
 - Limit Controller
 - Thermostat
 - Wiring

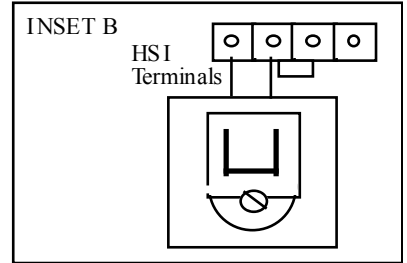
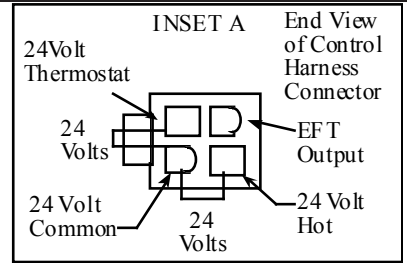

Plug Harness into SmartValve Control
Wait for Internal Check Delay (SV9501)

Igniter Warms UP and Glows Red

NO

Unplug Pilot Burner Cable.
Measure Voltage at SmartValve HSI Element Output (See Inset B)
24V Nominal

NO

Replace SmartValve Control

Note: Igniter Will Cycle OFF and Back ON Once During the 90 Second Ignition Trial

YES

Replace Igniter/Flame Rod Assembly

Reconnect Pilot Burner Cable

Reconnect Pilot Burner Cable

- Turn On Gas Supply
- Pilot Burner Lights

NO

• Check that Pilot Gas is Flowing
Wait to Assure Pilot Gas Tubing is Purged.

NO

Replace SmartValve Control

YES

• Measure Voltage Between 24V Hot and 24V Common Leads to SmartValve Control. Must Measure at Least 19.5 VAC with Igniter Powered. See Inset A to Identify Proper Lead. This Check Must be Done with the SmartValve Control Connected and Igniter Powered.

NO

Check Transformer and Line Volt Supply

Replace Igniter/Flame Rod Assembly

Main Valve Opens and Main Burner Lights

NO

- Check that Pilot Flame Makes Good Contact with Pilot Burner Flame Rod
- Check for Good Electrical Connection Through the Pilot Tubing
- If Both of the Above are Good, Replace Igniter/Flame Rod

YES

System is Okay

Cycle Thermostat OFF and Back ON

Main Burner Lights

NO

Replace SmartValve Control

HOW TO ORDER REPAIR PARTS

Parts can be ordered **only** through your **service person or dealer**. For best results, the **service person or dealer** should order parts through the distributor. Parts can be shipped directly to the **service person/dealer**.

All parts listed in the Parts List have a Part Number. When ordering parts, first obtain the Model Number from the name plate on your equipment. Then determine the Part Number (**not** the Index Number) and the Description of each part from the following appropriate illustration and list. Be sure to give all this information.

Furnace Model Number _____ Part Description _____

Furnace Serial Number _____ Part Number _____

Type of Gas (Propane or Natural) _____

Do not order bolts, screws, washers or nuts. They are standard hardware items and can be purchased at any local hardware store.

Shipments contingent upon strikes, fires and all causes beyond our control.

Empire Comfort Systems, Inc. Nine Eighteen Freeburg Ave. Belleville, IL 62222-0529

PARTS LIST

PLEASE NOTE: When ordering parts, it is very important that **part number** and **description** of part coincide.

Index No.	Part Number	Description	Index No.	Part Number	Description
1	DV-1213	TOP PLATE	39	M-156	GASKET
2	R-3165	DOOR CLIP (2 REQUIRED)	40	DV-775	SEAL BRACKET (SPP ONLY)
3	DV-1204	CASING SIDE - RIGHT	40	DV-691	SEAL BRACKET (IP ONLY)
4	DV-1202	CASING BACK	41	M-148	MANIFOLD GASKET
5	DV-1205	CASING SIDE - LEFT	42	DV-1235	PILOT BRACKET (IP ONLY)
6	DV-1249	AIR DROP	43	R-3031	BURNER (3 REQUIRED)
7	DV-1230	TURBULATOR (3 REQUIRED)	44	DV-1239	BURNER BRACKET
8	13213	OUTLET BOX REAR	45	UH-810	TRANSFORMER MOUNTING BRACKET (SPP ONLY)
9	13217	OUTLET BOX COVER	45	UH-452	TRANSFORMER MOUNTING BRACKET (IP ONLY)
10	R-3161	FAN BLADE	46	R-1995	TRANSFORMER (SPP ONLY)
11	R-3166	FAN MOTOR	46	R-998	TRANSFORMER (IP ONLY)
12	DV-1246	MOTOR MOUNTING BRACKET	47	UH-451	JUNCTION BOX COVER
13	R-1536	BUSHING (4 REQUIRED)	48	DV-572	JUNCTION BOX
14	R-1499	RUBBER GROMMET (4 REQUIRED)	49	R-1410	BUSHING
15	R-1454	BRASS BUSHING (4 REQUIRED)	50	R-690	CORD SET
16	R-3164	DOOR CLIP (2 REQUIRED)	51	R-1515	BUSHING
17	DV-1251	INNER SHIELD - RIGHT (INCLUDES NO. 22)	52	DV-1215	BOTTOM PLATE
18	R-6176	FAN CONTROL SWITCH	53	R-3034	PILOT - NAT (SPP ONLY)
19	R-3175	LIMIT SWITCH	53	R-3035	PILOT - LPG (SPP ONLY)
20	DV-1255	INNER SHIELD FRONT	54	GWT-021	PILOT BRACKET (SPP ONLY)
21	DV-1253	INNER SHIELD COVER PLATE (2 REQUIRED)	55	R-3180	ELECTRODE AND WIRE ASSEMBLY (SPP ONLY)
22	DV-1252	INNER SHIELD -LEFT (INCLUDES NO. 22)	56	R-2256	THERMOCOUPLE -18" (SPP ONLY)
23	13211	EXCHANGER ASSEMBLY	57	R-6389	WALL THERMOSTAT - 24 VOLT
24	R-3162	FILTER	58	13057	OUTLET TUBE - INNER ASSEMBLY (INCLUDES 59 & 60)
25	R-3163	FILTER RETAINER	59	M-177	GASKET - OUTER COLLAR
26	R-3232	PILOT - NAT (IP ONLY)	60	13104	OUTLET TUBE - INNER WELDED ASSEMBLY
26	R-3233	PILOT - LPG (IP ONLY)	61	13062	INLET TUBE - INNER ASSEMBLY (INCLUDES 62 & 63)
27	P-88-52	ORIFICE - NAT (3 REQUIRED)	62	M-178	GASKET - INLET COLLAR
27	P-88-60	ORIFICE - LPG (3 REQUIRED)	63	13106	INLET TUBE - INNER WELDED ASSEMBLY
28	DV-1236	MANIFOLD	64	13064	INLET TUBE - OUTER ASSEMBLY
29	DV-1259	FRONT PANEL	65	13059	OUTLET TUBE - OUTER ASSEMBLY
30	P-112	MANIFOLD UNION	66	13053	VENT CAP WELDED ASSEMBLY
31	R-1109	BUSHING	NOT SHOWN	DV-1261	PILOT TUBING
32	R-3170	GAS VALVE - NAT (IP ONLY)	NOT SHOWN	R-1081	PILOT ORIFICE - NAT (SPP ONLY)
32	R-3171	GAS VALVE - LPG (IP ONLY)	NOT SHOWN	R-1089	PILOT ORIFICE - LPG (SPP ONLY)
32	R-2148	GAS VALVE - NAT (SPP ONLY)	NOT SHOWN	R-1233	PILOT ORIFICE - NAT (IP ONLY)
32	R-5655	GAS VALVE - LPG (SPP ONLY)	NOT SHOWN	R-3265	PILOT ORIFICE - LPG (IP ONLY)
33	R-2708	PIEZO IGNITOR (SPP ONLY)	NOT SHOWN	R-3172	WIRE HARNESS (SPP ONLY)
34	DV-781	OBSERVATION HOLE COVER ASSEMBLY	NOT SHOWN	R-3173	WIRE HARNESS (IP ONLY)
35	M-155	GASKET	NOT SHOWN	R-3236	WIRE (IP ONLY)
36	FF-160	PIEZO BRACKET (SPP ONLY)	NOT SHOWN	DV-1264	HARDWARE PACKAGE
37	DV-1240	BURNER COMPARTMENT FRONT			
38	DV-1265	BURNER COMPARTMENT BODY			

USE ONLY MANUFACTURER'S REPLACEMENT PARTS. USE OF ANY OTHER PARTS COULD CAUSE INJURY OR DEATH.

PARTS VIEW

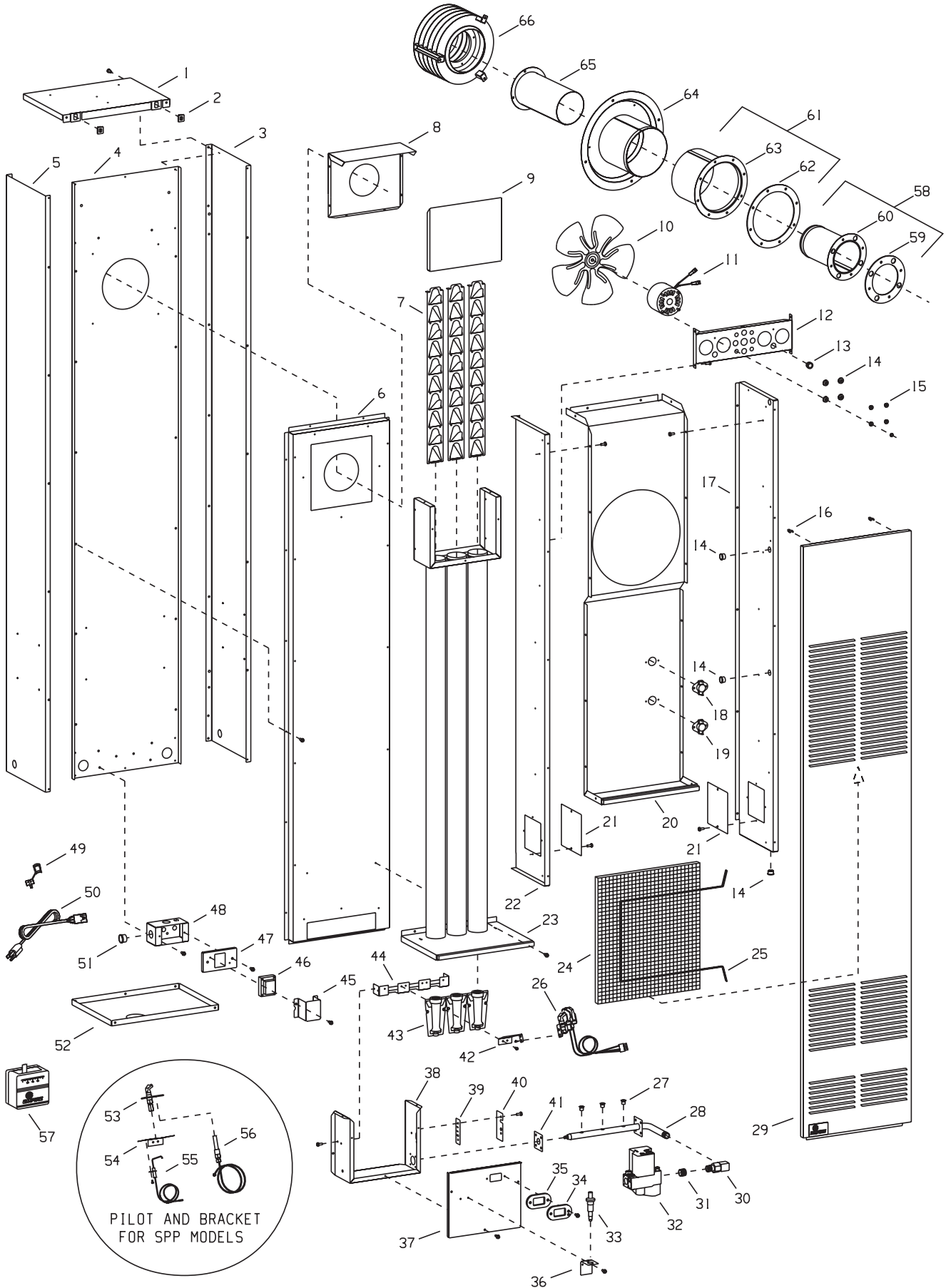



Empire Comfort Systems

Empire Comfort Systems, Inc.
918 Freeburg Ave. Belleville, IL 62220
PH: 618-233-7420 or 800-851-3153
FAX: 618-233-7097 or 800-443-8648
info@empirecomfort.com

www.empirecomfort.com