

INFINITY ICS, MODEL 58MVC  
DIRECT VENT 4-WAY MULTIPOISE  
MODULATING CONDENSING GAS FURNACE  
WITH IDEALCOMFORT™ IDEALHUMIDITY™



Turn to the Experts.™

## Owner's Manual

### NOTE TO INSTALLER:

THIS MANUAL MUST BE LEFT WITH THE EQUIPMENT USER.

**USER:** Please read all instructions in the manual and retain all manuals for future reference.



As an ENERGY STAR® Partner, Carrier Heating & Cooling Systems has determined that this product meets the ENERGY STAR® guidelines for energy efficiency.

### **WARNING**

#### **FIRE OR EXPLOSION HAZARD**

Failure to follow safety warnings exactly could result in injury, death, or property damage.

Do not store or use gasoline or other flammable vapors and liquids in the vicinity of this or any other appliance.

#### **WHAT TO DO IF YOU SMELL GAS**

- Do not try to light any appliance.
- Do not touch any electrical switch; do not use any phone in your building.
- Leave the building immediately.
- Immediately call your gas supplier from a neighbor's phone. Follow the gas supplier's instructions.
- If you cannot reach your gas supplier, call the fire department.

Installation and service must be performed by a qualified installer, service agency or the gas supplier.

### **WARNING**

#### **CARBON MONOXIDE POISONING HAZARD**

Failure to follow this warning could result in personal injury and/or death.

Carbon Monoxide is invisible, odorless, and toxic! Carrier Heating and Cooling Systems recommends a carbon monoxide alarm in your home, even if you do not own a gas appliance. Locate the carbon monoxide alarm in the living area of your home and away from gas appliances and doorways to attached garages. Follow the alarm manufacturer's instruction included with the alarm.

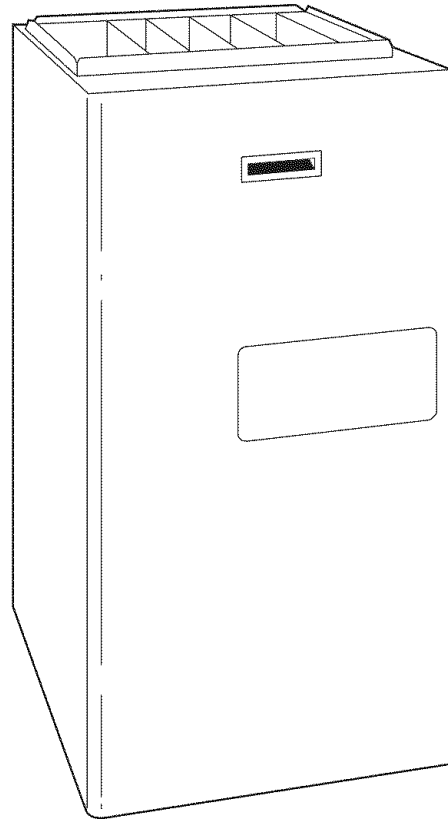

A05085

Do not use this furnace if any part has been under water. A flood-damaged furnace is extremely dangerous. Attempts to use the furnace can result in fire or explosion. A qualified service agency should be contacted to inspect the furnace and to replace all gas controls, control system parts, electrical parts that have been wet or the furnace if deemed necessary.

# TABLE OF CONTENTS

WELCOME TO A NEW GENERATION OF COMFORT . . .	2
FURNACE COMPONENTS . . . . .	3
SAFETY CONSIDERATIONS . . . . .	4
BEFORE STARTING YOUR FURNACE . . . . .	4
STARTING AND SHUTTING DOWN YOUR FURNACE . .	5
Steps for Starting Your Furnace . . . . .	5
Shutting Down Your Furnace . . . . .	7
PERFORMING ROUTINE MAINTENANCE . . . . .	7
Filtering Out Trouble . . . . .	8
COMBUSTION AREA AND VENT SYSTEM . . . . .	10
Heading South for the Winter . . . . .	11
A CHECK-UP CHECKLIST . . . . .	12
BEFORE YOU REQUEST A SERVICE CALL . . . . .	13
INSTALLATION DATA . . . . .	14

## WELCOME TO A NEW GENERATION OF COMFORT

Congratulations! In light of rising energy costs, the Infinity ICS Gas-Fired, Modulating Condensing Furnace is among the wisest investment today's homeowner can make.

Your new furnace is truly a triumph of technology in home heating. A revolutionary design employs two heat exchangers to maximize the amount of heat from the fuel consumed. In fact, your new furnace is so efficient, up to 95%\* of the heat generated during combustion is captured and delivered inside your home. That is more than a 33%\* increase in heating efficiency over conventional furnaces.

These are among the most energy-efficient furnaces you can buy today. They also are among the safest and most dependable. We are proud of the technological advances incorporated into the design of these furnaces. With only minimal care, your new furnace will deliver many years of money-saving home comfort and enjoyment. Spend just a few minutes with this manual to learn the operation of your new furnace and the small amount of maintenance it takes to help keep it operating at peak efficiency year after year.

\*The output capacity and any representations of efficiency for this furnace are based on standard U.S. Department of Energy test procedures.

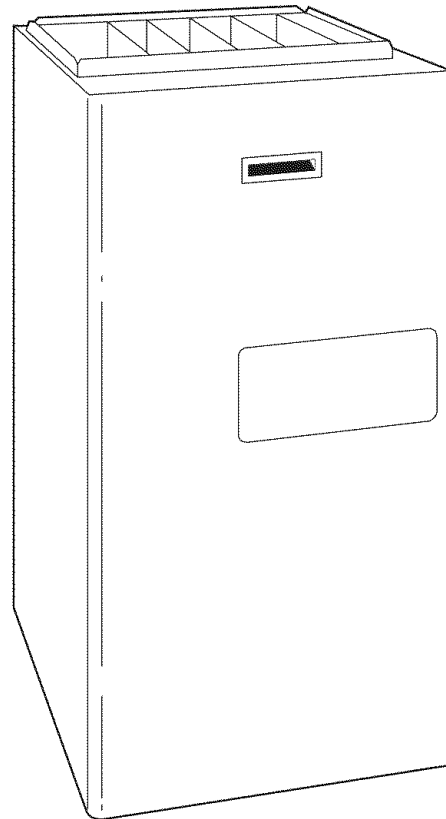
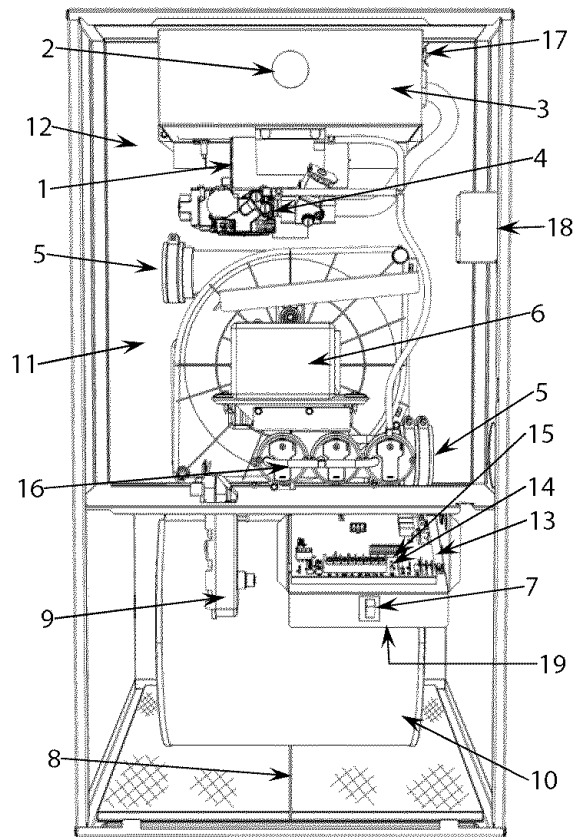

Fig. 1 - Infinity ICS Variable Capacity Furnace

A05085

# FURNACE COMPONENTS



**Fig. 2 - Model 58MVC Furnace**

A07609

1. Combustion-air intake connection to ensure contaminant-free air (right or left side).
2. Burner sight glass for viewing burner flame.
3. Burner assembly (inside). Operates with energy-saving inshot burners and hot surface igniter for safe, dependable heating.
4. Redundant gas valve. Safe and efficient. Features 1 gas control with 2 internal shutoff valves and one throttling valve.
5. Vent outlet. Uses PVC pipe to carry flue gas from the furnace's combustion system (right or left side).
6. Inducer motor. Pulls hot flue gases through the heat exchangers, maintaining negative pressure for added safety.
7. Blower access panel safety interlock switch.
8. Air filter and retainer (location in furnace may vary).
9. Condensate drain connection. Collects moisture condensed from burned gases for disposal into home drain system. (Location in furnace varies.)
10. Heavy-duty blower. Circulates air across the heat exchangers to transfer heat into the home.
11. Everlastic™ Secondary condensing heat exchanger (inside). Wrings out more heat through condensation. Constructed with polypropylene-laminated steel to ensure durability.
12. Primary serpentine heat exchanger (inside). Stretches fuel dollars with the S-shaped heat-flow design. Solid construction of corrosion-resistant aluminized steel means reliability.
13. Furnace control board.
14. 3-amp fuse provides electrical and component protection.
15. Light emitting diode (LED) on furnace control board. Status code light is for diagnosing furnace operation and service requirements.
16. Pressure switches ensure adequate flow of flue gas through furnace and out vent system.
17. Rollout switch (manual reset) to prevent overtemperature.
18. Junction box for 115-v electrical power supply. (May be located on right or left side)
19. Transformer (24v) behind furnace control board provides low-voltage power to furnace control board and thermostat.

## SAFETY CONSIDERATIONS

Recognize safety information. This is the safety-alert symbol . When you see this symbol on the furnace and in instructions or manuals, be alert to the potential for personal injury.

Understand the signal words: DANGER, WARNING, and CAUTION. DANGER identifies the most serious hazards which **will** result in severe personal injury or death. WARNING signifies hazards which **could** result in personal injury or death. CAUTION is used to identify unsafe practices which **may** result in minor personal injury or product and property damage. NOTE is used to highlight suggestions which **will** result in enhanced installation, reliability or operation.

To minimize the possibility of serious personal injury, fire, furnace damage, or improper operation; **carefully follow these safety rules:**

- Your gas furnace uses air from outside the home for combustion and vents flue gas to the outdoors. It is not to be installed using indoor air for combustion. The vent pipe must terminate outside the structure and must not be obstructed in any way. The air-intake pipe must terminate outside the structure or in a well ventilated area that is isolated from the living space and the garage (e.g. well ventilated attic or crawlspace). Do not block or obstruct air openings on furnace or spaces around furnace.

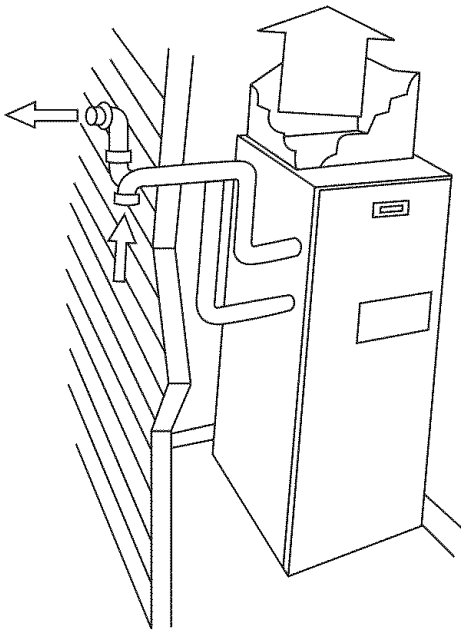

Fig. 3 - Venting

A05089

- Keep the area around your furnace clear and free of combustible materials, gasoline, and other flammable liquids and vapors.

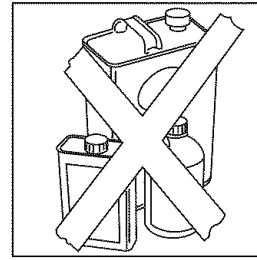

Fig. 4 - Combustible Materials

A92182

- Do not cover the furnace, store trash or debris near it, or in any way block the flow of fresh air to the unit.
- A furnace installed in an attic or other insulated space must be kept free and clear of insulating material. Examine the furnace area when the furnace is installed or when insulation is added. Some materials may be combustible.
- This furnace contains SAFETY DEVICES which must be MANUALLY RESET. If the furnace is left unattended for an extended period of time, have it checked periodically for proper operation. This precaution will prevent problems associated with no heat, such as frozen water pipes, etc. See "Before You Request a Service Call" section in this manual.

### WARNING

#### FIRE OR EXPLOSION HAZARD

Failure to follow this warning could result in personal injury/death or property damage.

Do not keep combustible materials, gasoline, and other flammable liquids or vapors around your furnace.

### WARNING

#### FIRE AND UNIT OPERATION HAZARD

Failure to follow this warning could result in personal injury/death or property damage.

For proper and safe operation the furnace needs air for combustion and ventilation. Do not block or obstruct the openings on the furnace, air openings to the area in which the furnace is installed, and the space around the furnace.

# BEFORE STARTING YOUR FURNACE

Examine the furnace installation monthly to determine that:

1. All flue gas carrying areas external to the furnace (i.e. chimney, vent connector) are clear and free of obstructions.
2. The vent connector is in place, slopes upward and is physically sound without holes or excessive corrosion.
3. The return-air duct connection(s) is physically sound, is sealed to the furnace casing, and terminates outside the space containing the furnace.
4. The physical support of the furnace is sound without sagging cracks, gaps, etc. around the base.
5. There are no obvious signs of deterioration of the furnace.

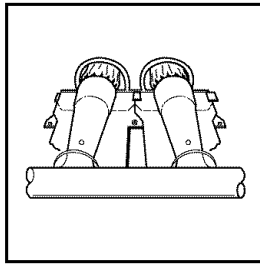

Fig. 5 - Burner Flame

A92330

6. The burner flames are in good adjustment. (See Fig. 5.)

# STARTING AND SHUTTING DOWN YOUR FURNACE

Instead of a continuously burning pilot flame which wastes valuable energy, your furnace uses an automatic, hot surface ignition system to light the burners each time the thermostat starts your furnace. **Follow these important safeguards:**

- Never attempt to manually light the burners with a match or other source of flame.

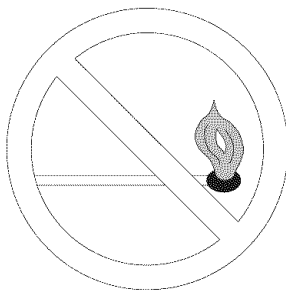

Fig. 6 - Do Not Light Burner with Match

A92319

- Read and follow the operating instructions on inside of main furnace door, especially the item that reads as follows:  
Wait 5 minutes to clear out any gas. Then smell for gas, including near the floor. If you smell gas, **STOP!** Follow "B" in the safety information above on this furnace label. If you don't smell gas, go to the next step.
- If a suspected malfunction occurs with your gas control system, such as the burners do not light when they should, refer to the shutdown procedures on inside of main furnace door, or in the "Shutting Down Your Furnace" section and call your dealer as soon as possible.

# ⚠ WARNING

## FIRE AND EXPLOSION HAZARD

Failure to follow this warning could result in personal injury/death or property damage.

Should the gas supply fail to shut off or if overheating occurs, turn off the manual gas valve to the furnace **BEFORE** turning off the electrical supply. (See Fig. 8.)

- **CHECK AIR FILTER:** Before attempting to start your furnace, be sure the furnace filter is clean and in place. See "Performing Routine Maintenance" section in this manual. Then proceed as follows:

## Steps For Starting Your Furnace

1. Set your room thermostat to the lowest temperature setting. (See Fig. 7.)
2. Close the external manual gas valve. (See Fig. 8.)

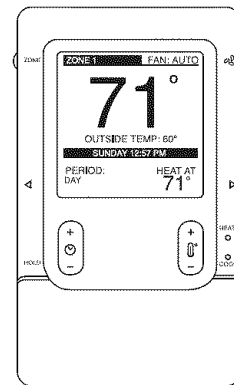

Fig. 7 - Lowest Temperature Setting

A08013

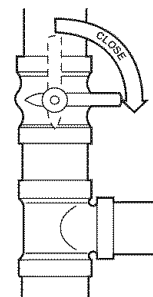

Fig. 8 - Close Valve

A06188

3. Turn OFF electrical supply to the furnace. (See Fig. 9.)
4. Remove main furnace door. (See Fig. 10.)
5. The gas valve will have a control switch to turn off and on. Turn the control switch on the gas control to the OFF position and wait 5 minutes. (See Fig. 11.) Then smell for gas, including near the floor. If you smell gas, **STOP!** Follow "B" on furnace label. If you don't smell gas, go to next step.
6. After waiting 5 minutes, turn the control switch on the gas control to the ON position. (See Fig. 12.)

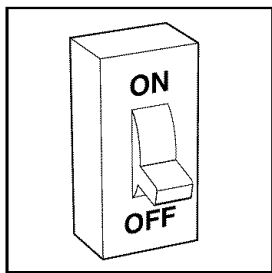

Fig. 9 - Turn Off Electrical Supply

A92185

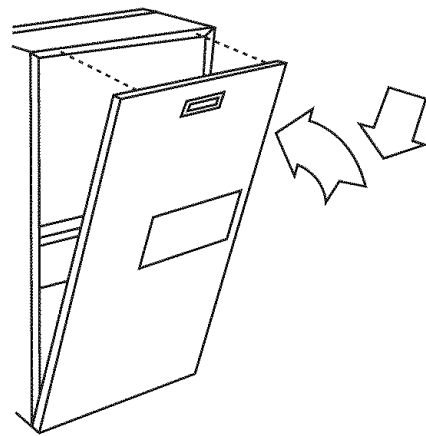

Fig. 13 - Furnace Door Replaced

A05088

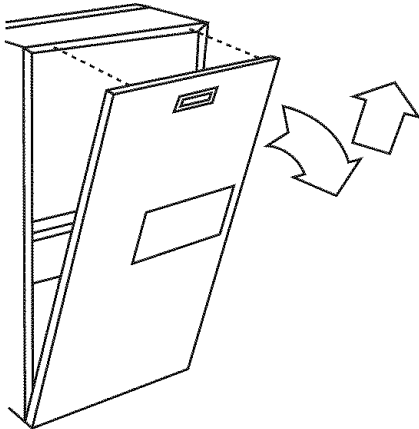

Fig. 10 - Remove Furnace Door

A05087

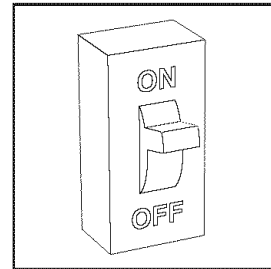

Fig. 14 - Turn On Electrical Supply

A92359

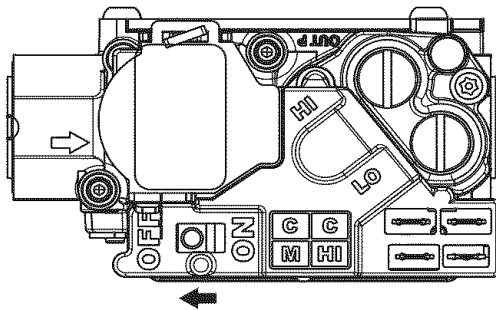

Fig. 11 - Control Switch to OFF

A04150

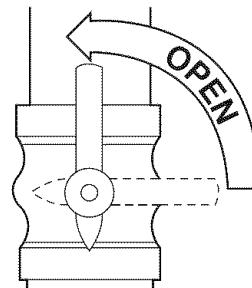

Fig. 15 - Open Valve

A06189

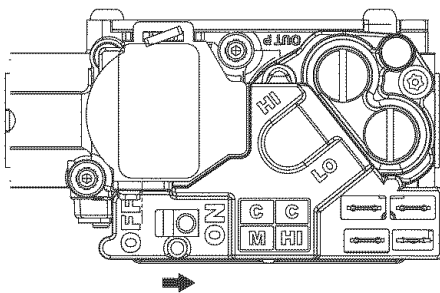

Fig. 12 - Control Switch to ON

A04151

7. Replace main furnace door. (See Fig. 13.)
8. Turn ON the electrical supply to the furnace and wait 1 minute. (See Fig. 14.)
9. Open the external manual gas valve. (See Fig. 15.)
10. Set the room thermostat to a temperature slightly above the room temperature. This will automatically signal the furnace to start.
11. When the furnace receives the start signal, the inducer is started. When the pressure switch senses that there is sufficient combustion air, the hot surface igniter is energized. After the hot surface igniter is heated for 17 seconds, the gas valve permits gas to flow to the main burners. After ignition and a time delay of about 30 sec, the furnace blower will start. Variable-capacity furnaces start at medium speed until the control makes the necessary adjustments to operate the blower at either the low-, medium-, or high-heat speed.

**NOTE:** If the burners fail to ignite after 4 attempts, the furnace control system will lock out. If lockout occurs, main burners fail to light, or blower does not come on, shut down the furnace and call your dealer for service.

12. Set your thermostat to the temperature that satisfies your comfort requirements.

**SUGGESTION:** Setting the thermostat back a few degrees and compensating for the difference with warmer clothing can make a big difference in your fuel consumption. The few degrees at the top of your thermostat “comfort level” are the most costly degrees to obtain.

When the room temperature drops below the temperature selected on the thermostat, the furnace will switch on automatically. When the room temperature reaches the temperature selected on the thermostat, the furnace will be switched off automatically.

Some thermostats have a FAN mode with 2 selections: AUTO and ON. When set on AUTO, the furnace blower cycles on and off. In the ON mode, the furnace blower runs continuously. Continuous fan keeps the temperature level in your home more evenly balanced. It also permits the indoor air to be continuously filtered. With the unique feature Fan On Plus™, the blower speed can be increased or decreased if desired due to change of seasons, large gatherings in your home, etc. Simply change your FAN from ON to OFF for 1 to 3 seconds (or AUTO depending on your thermostat), and then return to ON. The blower will switch to the next higher speed. There are at least 3 speeds to choose from. If the blower is running on its highest speed, a request to change will direct the blower to return to its lowest speed.

If you own an Evolution Control, simply push the “fan” button to change the fan speed.

## SHUTTING DOWN YOUR FURNACE

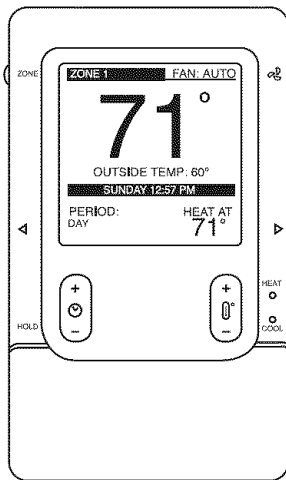
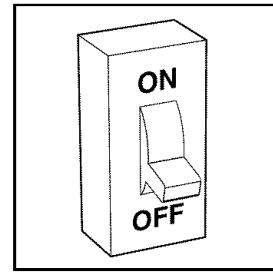

**Fig. 16 - Lowest Temperature Setting**

A08013

Should you ever need to shut down your furnace for service or maintenance, you will need to turn the furnace off. The following procedures must be followed:

1. Set your room thermostat to the lowest temperature setting. (See Fig. 16.)
2. Turn off electrical supply to the furnace. (See Fig. 17.)
3. Remove main furnace door. (See Fig. 10.)
4. Turn the switch on the gas control to the OFF position. (See Fig. 18.)



**Fig. 17 - Turn Off Electrical Supply**

A92185

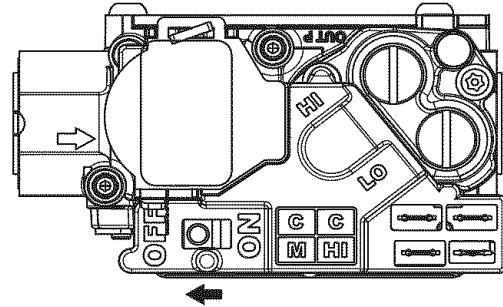

**Fig. 18 - Control Switch to OFF**

A04150

5. Replace the main furnace door. (See Fig. 13.)
6. If the furnace is being shut down because of a malfunction, call your dealer as soon as possible.

**⚠ CAUTION**

**UNIT AND PROPERTY DAMAGE**

Failure to follow this caution may result in damage to the furnace and other property damage.

Furnace is not to be installed, operated, and then turned off and left turned off in an unoccupied structure during winter. (See “Heading South for the Winter” procedures in maintenance section on page 12).

## PERFORMING ROUTINE MAINTENANCE

**NOTE:** The qualified installer or agency must use only factory-authorized replacement parts, kits, and accessories when modifying this product.

Installing and servicing heating equipment can be hazardous due to gas and electrical components.

Only trained and qualified personnel should install, repair, or service heating equipment. Untrained personnel can perform basic maintenance functions such as cleaning and replacing air filters.

All other operations must be performed by trained and qualified service agency personnel. Observe safety precautions in this manual, on tags, and on labels attached to the furnace, and other safety precautions that may apply.

With proper maintenance and care, your furnace will operate economically and dependably. Instructions for basic maintenance are found on this and the following pages. However, before beginning maintenance, follow these safety precautions:

## **⚠ WARNING**

### **ELECTRICAL SHOCK HAZARD**

Failure to follow this warning could result in personal injury/death.

Turn off electrical power supply to your furnace before removing the access doors to service or perform maintenance.

## **⚠ CAUTION**

### **CUT HAZARD**

Failure to follow this caution may result in minor personal injury.

Although special care has been taken to minimize sharp edges, be extremely careful when handling parts or reaching into the furnace.

### **Filtering Out Trouble**

## **⚠ CAUTION**

### **UNIT PERFORMANCE HAZARD**

Failure to follow this caution may result in product damage.

Never operate your furnace without a filter in place. Doing so may damage the furnace blower motor. An accumulation of dust and lint on internal parts of your furnace can cause a loss of efficiency.

A dirty air filter will cause a loss of airflow in your duct system. When excessive loss of airflow occurs, the furnace may cycle on its safety controls. If this condition is left unattended, the furnace will eventually lock out. It is recommended that the furnace air filter be checked every 3 or 4 weeks and cleaned if necessary.

If installed with factory-specified disposable media filter, check or replace filter before each heating and cooling season. Replace disposable media filter at least once a year.

The air filter is normally located in the blower compartment or in the factory-supplied filter cabinet attached to the side or bottom of the furnace casing. If air filter has been installed in another location, contact your dealer for instructions. To inspect, clean, and/or replace the air filter(s), follow these steps:

1. Turn off electrical supply to furnace. (See Fig. 17.)
2. Remove door/access panel.
  - a. Air Filters Located in Blower Compartment
    - (1.) Remove main furnace door. (See Fig. 19.)
    - (2.) Remove blower access panel. (See Fig. 20.)

**NOTE:** It will be necessary to remove 2 screws

- b. Air Filters Located in Filter Cabinet  
Remove filter cabinet door. (See Fig. 21 and 22.)

**NOTE:** It will be necessary to remove 1 thumbscrew

3. Remove air filter from furnace.
  - a. Air Filters Located in Blower Compartment Bottom:
    - (1.) Slide filter retainer sideways until it is free of latch. (See Fig. 23.)
    - (2.) Slide air filter out of furnace. (See Fig. 24.)
  - b. Air Filters Located in Blower Compartment Side:
    - (1.) Remove filter retainer from latch. (See Fig. 25.)

- (2.) Gently remove air filter and carefully turn the dirty side up (if dirty) to avoid spilling dirt from the filter. (See Fig. 26.)

- c. Air Filter Located in Filter Cabinet:  
Slide air filter out of furnace. Keep dirty side up (if dirty) to avoid spilling dirt. (See Fig. 27 and 28.)

4. Inspect the filter. If torn, replace it.

**NOTE:** If washable filter that was shipped with the furnace has been replaced by:

- Factory specified disposable media filter: Do not clean. If dirty, replace only with media filter having the same part number and size. Install with airflow direction arrow pointing towards blower.
- Electronic air cleaner (EAC): Refer to EAC Owner's Manual for maintenance information.

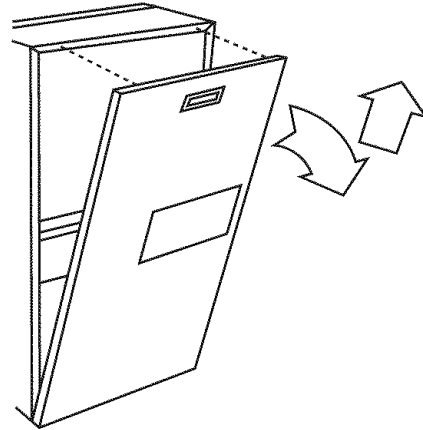

**Fig. 19 - Removing Furnace Door**

A05087

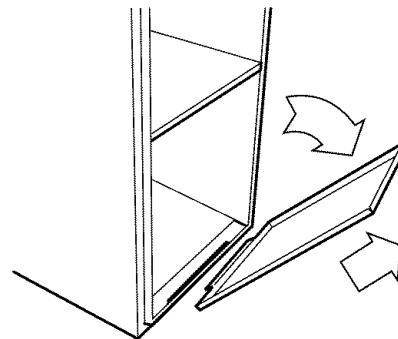

**Fig. 20 - Removing Blower Access Panel**

A93204

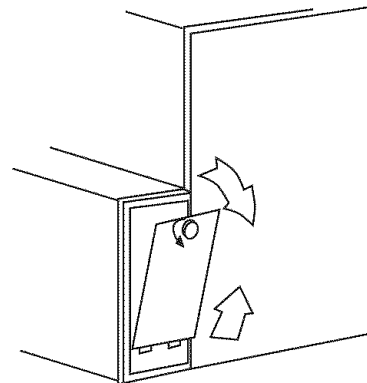

**Fig. 21 - Removing Side Filter Cabinet Door**

A06190



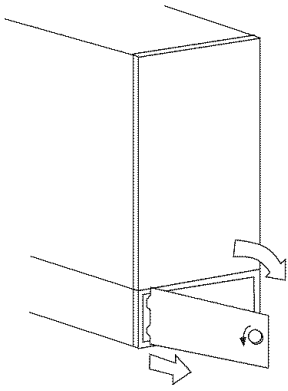

**Fig. 22 - Removing Bottom Filter Cabinet Door**

A06191

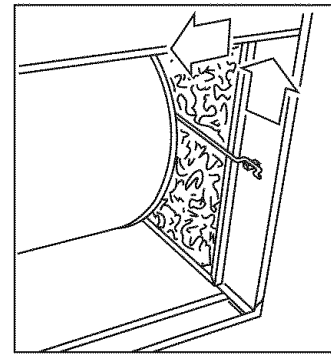

**Fig. 25 - Removing Filter Retainer from Latch**

A93012

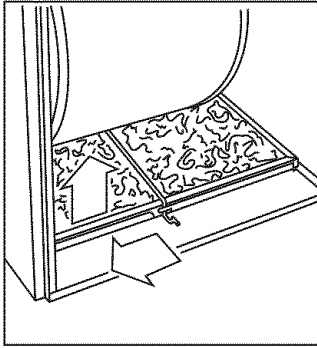

**Fig. 23 - Sliding Filter Retainer Sideways**

A93010

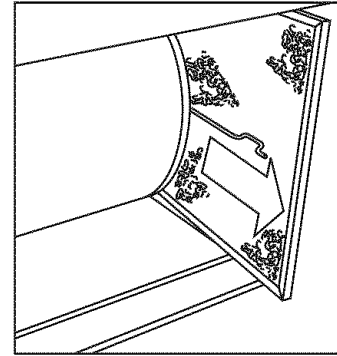

**Fig. 26 - Removing Air Filter**

A93013

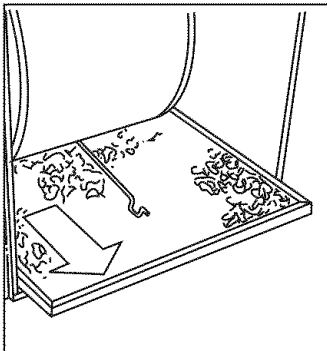

**Fig. 24 - Slide Air Filter Out of Furnace**

A93011

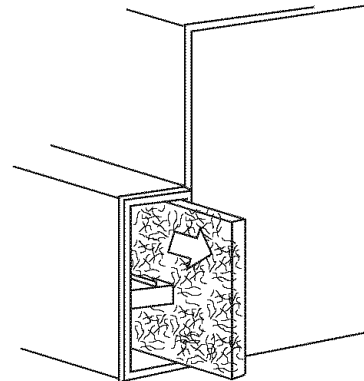

**Fig. 27 - Slide Side Filter Out of Furnace**

A00227

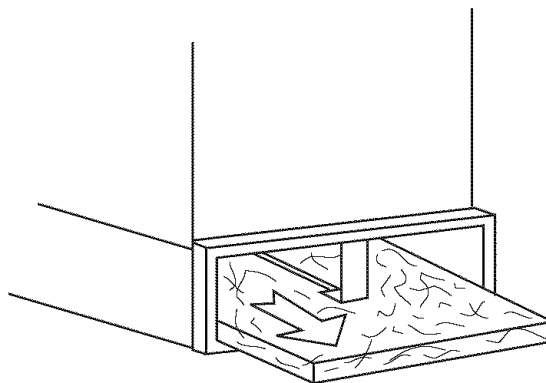

**Fig. 28 - Slide Bottom Filter Out of Furnace**

A00228

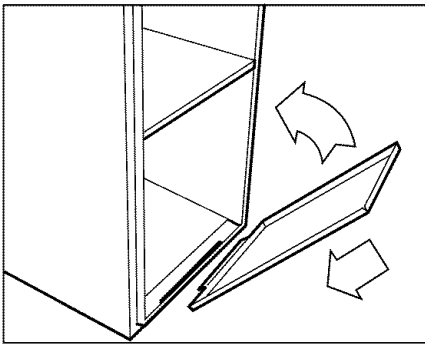

**Fig. 29 - Replace Blower Access Panel**

A93205

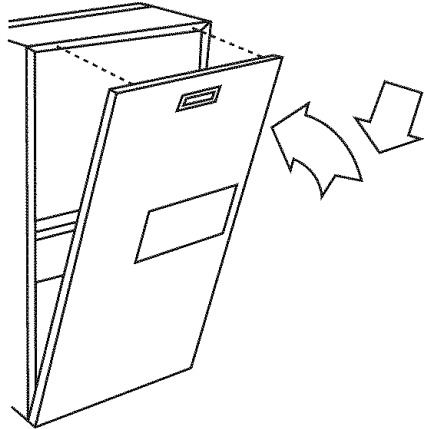

**Fig. 30 - Replace Furnace Door**

A05088

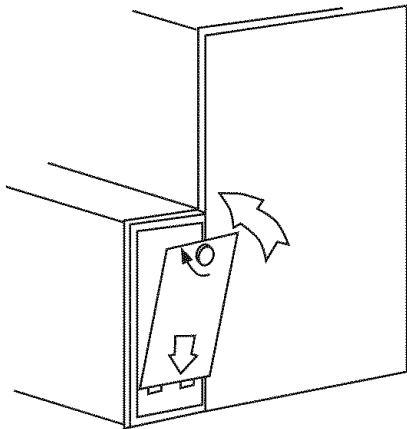

**Fig. 31 - Replace Side Filter Cabinet Door**

A06192

5. If washable filter, wash filter (if dirty) in sink, bathtub, or outside with a garden hose. Always use cold tap water. A mild liquid detergent may be used if necessary. Spray water through filter in the opposite direction of airflow. Allow filter to dry.
6. Reinstall clean air filter.
7. Reinstall filter retainer (for blower compartment locations only).
8. Replace blower access panel and main furnace door (Fig. 29 and 30.) or filter cabinet door. (Fig. 31 and 32.)
9. Turn on electrical supply to furnace.

If your furnace air filter needs to be replaced, be sure to use a factory-authorized filter of the same size that was originally

supplied. Use the filter tables and compare your furnace size with the proper filter size.

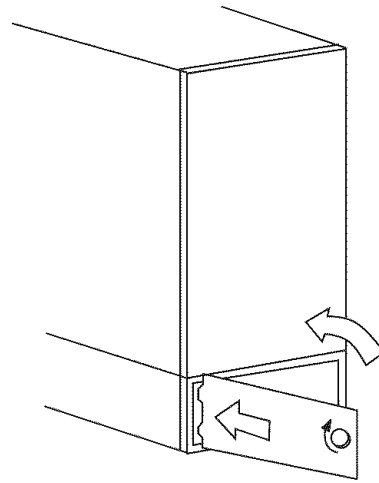

**Fig. 32 - Replace Bottom Filter Cabinet Door**

A06193

**FURNACE AIR FILTER TABLE**

AIR FILTER LOCATED IN BLOWER COMPARTMENT			
FURNACE CASING WIDTH (IN.)	FILTER SIZE (IN)		FILTER TYPE
	Side Return†*	Bottom Return*	
17-1/2	(1) 16 x 25 x 1	(1) 16 x 25 x 1	Cleanable
21	(1) 16 x 25 x 1	(1) 20 x 25 x 1	Cleanable
24-1/2	(1 or 2) 16 x 25 x 1	(1) 24 x 25 x 1	Cleanable
AIR FILTER LOCATED IN FILTER CABINET			
FILTER CABINET HEIGHT (IN)	FILTER SIZE (IN)	FILTER TYPE	
16	(1) 16 x 25 x 1*	Cleanable or Disposable	
20	(1) 20 x 25 x 1* or (1) 20 x 25 x 4-5/16	Cleanable or Disposable	
24	(1) 24 x 25 x 1* or (1) 24 x 25 x 4-5/16	Cleanable or Disposable	

\*Factory—provided with the furnace. Filters may be field modified by cutting filter material and support rods (3) in filters.

† Upflow only. Alternate sizes and additional filters may be ordered from your dealer.

## ⚠ WARNING

**PERSONAL INJURY HAZARD**

Failure to follow this warning could result in personal injury.

Use care when cutting support rods in filters to protect against flying pieces and sharp rod ends. Wear safety glasses, gloves, and appropriate protective clothing.

# COMBUSTION AREA AND VENT SYSTEM

Visually inspect the combustion area and vent system before each heating season. Make sure that all PVC pipes leading into the combustion area and vent are free from any cracks and sags.

## **⚠ WARNING**

### **CARBON MONOXIDE POISONING HAZARD**

Failure to follow this warning could result in personal injury or death.

If holes are found in the pipes or if any portion has become disconnected, toxic fumes can escape into your home. **DO NOT OPERATE YOUR FURNACE.** Call your dealer for service.

Check the combustion-air intake and vent pipe on the outside of your home for blockage.

When dirt, soot, scale, or rust is allowed to build up, your furnace can suffer a loss of efficiency and perform improperly. Accumulations on the main burners can result in firing out of normal sequence. This delayed ignition creates an alarmingly loud sound.

## **⚠ CAUTION**

### **UNIT OPERATION HAZARD**

Failure to follow this caution may result in property damage.

If your furnace makes an especially loud noise when the main burners light, shut down your furnace and call your dealer.

To inspect the combustion area and vent system, you will need a flashlight. Refer to Fig. 3 and proceed as follows:

## **⚠ WARNING**

### **CARBON MONOXIDE POISONING HAZARD**

Failure to follow this warning could result in personal injury or death.

If dirt, rust, soot, or scale accumulations are found, call your dealer. Do not operate your furnace.

1. Turn off the gas and electrical supplies to the furnace and remove the main furnace door. (See Fig. 8, 9, and 10.)
2. Remove burner enclosure front. (See Fig. 33.)

Inspect the gas burners, igniter area, and remainder of furnace for dirt, rust, soot, or scale.

3. Inspect the combustion-air and vent PVC pipes for sags, holes, cracks, water leaks, blockage or disconnections. Horizontal portions of pipes must slope downward toward furnace.
4. Reinstall burner enclosure front.
5. If your furnace is free of the above conditions, replace main furnace door and turn on electrical and gas supplies to the furnace. (See Fig. 13, 14, and 15.)
6. Start the furnace and observe its operation. Watch the burner flames to see if they are clear blue, almost transparent. (See Fig. 34.) If you observe a suspected malfunction, or the burner flames are not clear blue, call your dealer.

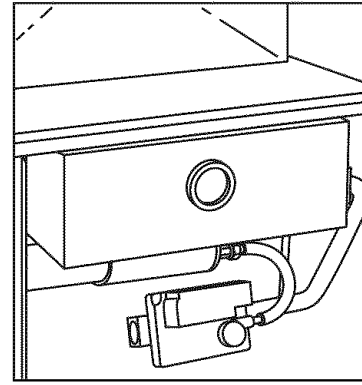

Fig. 33 - Remove Burner Enclosure Front

A00223

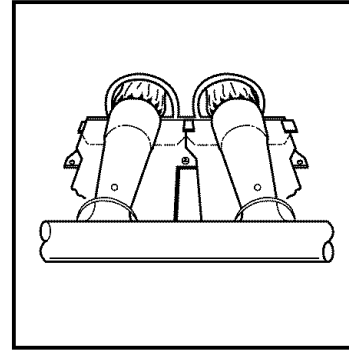

Fig. 34 - Burner Flame

A92330

## HEADING SOUTH FOR THE WINTER? DON'T FORGET YOUR FURNACE!

## **⚠ CAUTION**

### **UNIT AND PROPERTY DAMAGE HAZARD**

Failure to follow this caution may result in damage to the furnace and other property damage.

If the furnace is installed in an unconditioned space where the ambient temperatures may be 32°F (0°C) or lower, freeze protection measures must be taken to prevent minor property or product damage.

## **⚠ CAUTION**

### **UNIT COMPONENT DAMAGE HAZARD**

Failure to follow this caution may result in damage to the furnace and other property damage.

Do not use ethylene glycol (Prestone II antifreeze coolant or equivalent). Failure of plastic components may occur.

Since the furnace uses a condensing heat exchanger, some water will accumulate in the unit as a result of the heat transfer process. Therefore, once it has been operated, it cannot be turned off and left off for an extended period of time when temperatures will reach 32°F (0°C) or lower unless winterized. Follow these procedures to winterize your furnace:

1. Obtain propylene glycol (RV/swimming pool antifreeze or equivalent).
2. Turn off electrical supply to the furnace. (See Fig. 17.)

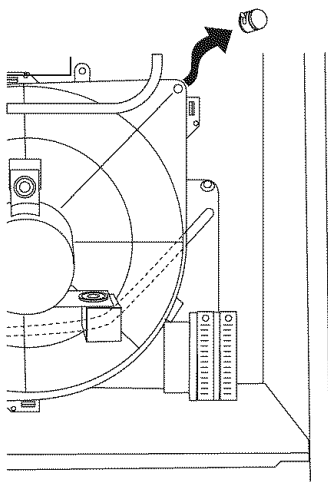

**Fig. 35 - Upper Inducer Housing Drain Connection Cap**

A06456

3. Remove main furnace door. (See Fig. 19.)
4. Remove upper inducer housing drain connection cap. (See Fig. 35.)
5. Connect field-supplied 1/2-in. ID tube to upper inducer housing drain connection.
6. Insert field-supplied funnel into tube.
7. Pour 1 quart of antifreeze into funnel/tube. Antifreeze should run through inducer housing, overflow condensate trap, and flow into open field drain. (See Fig. 36.)

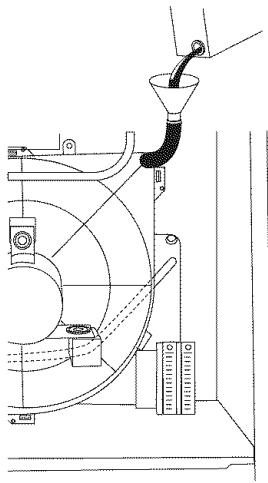

**Fig. 36 - Pour Antifreeze**

A06457

8. Remove funnel and tube from inducer housing and replace drain connection cap and clamp.
9. Replace main furnace door. (See Fig. 30.)
10. Propylene glycol need not be removed before restarting furnace.

## ⚠ CAUTION

### UNIT AND PROPERTY DAMAGE HAZARD

Failure to follow this warning could result in damage to unit components.

This furnace is designed for continuous return-air minimum temperature of 60°F (15.6°C) db or intermittent operation down to 55°F (12.8°C) db, such as when used with a night setback thermostat. Return-air temperature must not exceed 85°F (29.4°C) db.

If you choose to leave your furnace on during extended absences do not set your thermostat lower than the limits shown in the Caution box above.

To protect your property from damage from potential problems due to unintended interruptions in utility services or other events, it is recommended that you either winterize your plumbing system or have someone check on your house regularly while you are away.

Your dealer or a licensed plumber can give you additional advice about winterizing your plumbing system.

## A CHECK-UP CHECKLIST

Your furnace represents an important investment in your family's comfort and your home's value. To keep it performing properly and to prevent future problems, have a trained service specialist give your furnace a professional check-up annually. The following checklist can be used as a guideline to proper service:

- Inspect all flue gas passages, burners, heat exchangers, coupling box(es), and inducer assembly.
- Inspect all combustion-air and vent piping inside structure and vent pipe termination outside the structure.
- Check gas pipes leading to and inside your furnace for leaks.
- Inspect and clean the blower motor and wheel.

**NOTE:** The inducer and blower motors are pre-lubricated and require no additional lubrication. These motors can be identified by the absence of oil ports on each end of the motor.

- Inspect and change or clean air filters(s), if necessary.
- Inspect all supply- and return-air ducts for obstructions, air leaks, and insulation. Remedy any problem when necessary.
- Inspect the return-air duct connections(s) at the furnace to ensure it is physically sound, sealed to the furnace casing, and terminates outside the space containing the furnace.
- Inspect electrical wiring, connections, and components for loose connections.
- Perform an operational checkout to determine whether your furnace is working properly and if it requires adjustments.
- Inspect all condensate drain tubes and condensate trap assembly for leaks. The condensate removal system should be cleaned annually by a qualified service agency. Refer to the Service and Maintenance Instructions for further information.
- Examine the physical support of the furnace. Support should be sound with no cracks, sagging, gaps, etc. around the base.
- Check furnace for any obvious signs of deterioration.

## BEFORE YOU REQUEST A SERVICE CALL

If your furnace is not operating or not performing properly, you may save the expense of a service call by checking a few things yourself before calling for service.

### For Insufficient Airflow:

- Check for dirty air filter(s).
- Check for blocked return-air or supply-air grilles throughout your home. Ensure they are open and unobstructed.

If problem still exists, call your dealer for service.

### If Furnace Fails to Operate:

Follow this checklist step by step, advancing to the next step only if furnace fails to start.

- Check thermostat for proper temperature. Is thermostat set above room temperature?
- Is thermostat set on HEAT?
- Check fuses and circuit breakers. Is electrical supply on?
- Is manual shutoff valve in gas supply pipe in open position? (Follow start-up procedures if you open gas valve.)

**NOTE:** Turn off electrical supply before continuing with checklist.

- Is control switch on gas valve in ON position? (Follow startup procedures if you must reset switch to ON position.)
- Check manual reset flame rollout switch located on the burner box. If furnace has experienced high temperature conditions, this switch will shut off the furnace. Reset it by pushing the button on the switch. If it trips again, shut down the furnace and call for service. See “Shutting Down Your Furnace” section in this manual.
- Check for obstructions around the vent termination outside the structure.

If the furnace still fails to operate, call your service representative.

For your convenience, record the furnace product and serial numbers on back page. Should you ever require service, you will have ready access to the information needed by your service representative.

This furnace has a light-emitting-diode (LED) status code display to aid the installer, service technician, or homeowner while installing or servicing the unit. The LED code can be seen by removing the main furnace door and viewing the LED through the view port in the blower access panel. (See Fig. 2.)

### NOTE TO EQUIPMENT OWNER:

For your convenience, please record the model and serial numbers of your new equipment in the spaces provided. This information, along with the installation data and dealer contact information will be helpful should your system require maintenance or service.

#### FURNACE

Model # \_\_\_\_\_

Serial # \_\_\_\_\_

#### AIR CONDITIONER OR HEAT PUMP

Model # \_\_\_\_\_

Serial # \_\_\_\_\_

#### INDOOR COIL (Furnace Coil or Fan Coil)

Model # \_\_\_\_\_

Serial # \_\_\_\_\_

#### INSTALLATION INFORMATION:

Date Installed \_\_\_\_\_

#### DEALERSHIP CONTACT INFORMATION:

Company Name \_\_\_\_\_

Address \_\_\_\_\_

Phone Number \_\_\_\_\_

Technician Name \_\_\_\_\_

#### NOTE TO INSTALLER:

This manual must be left with the equipment owner.



Turn to the Experts.™

TO OBTAIN INFORMATION ON PARTS: Consult your installing dealer or classified section of your local telephone directory under the "Heating Equipment" or "Air Conditioning Contractors & Systems" heading for dealer listing by brand name. Have available the Model No., Series Letter, & Serial No. of your equipment to ensure correct replacement part.