

Installation, Start-Up and Service Instructions

NOTE: Read the entire instructions before starting the installation.

NOTE: The Energy Guide tag can be removed from the furnace when the installation is complete.

INTRODUCTION

Before installing the furnace, refer to "Procedures for Natural-Draft Gas-Fired Furnaces" (packaged with the equipment) for information concerning combustion, venting, piping, and other standard installation practices. Further reference is made to the current edition of the National Fuel Gas Code NFPA No. 54, TIA-54-1984-1/ANSI Z223.1-1984, Z223.1a-1987.

Each furnace is shipped from the factory completely assembled with multispeed direct-drive blower and wired ready for downflow indoor heating installation only. All sizes feature a printed-circuit board control center with easy-to-read, low-voltage terminal strip to ensure proper connections.

CAUTION

Do not install furnace in a damp, corrosive, or contaminated atmosphere. Make sure all combustion and circulating air requirements listed in "Procedures for Natural-Draft Gas-Fired Furnaces" are adhered to, in addition to all local codes and ordinances.

Do not use this furnace during construction when adhesives, sealers and/or new carpets are being installed. If the furnace is required during construction, use clean outside air for combustion and ventilation. Compounds of chlorine and fluorine when burned with combustion air form acids which will cause corrosion of the heat exchangers and metal vent system. Some of these compounds are paneling and dry wall adhesives, paints, thinners, masonry cleaning materials, and many other solvents commonly used in the construction process.

The design of the downflow gas-fired furnace is A.G.A. certified for installation on noncombustible flooring. The furnace may be installed on combustible flooring when installed with the accessory floor base. This furnace is for installation in alcoves, basements, closets, or utility rooms. This furnace line is **not** A.G.A. design certified for installation in a mobile home, recreation vehicle, or outdoors.

Installation comprises the following:

- *I. Inspection
- *II. Location, Ventilation, and Air for Combustion
- *III. Gas Piping
- *IV. Venting
 - V. Supply-Air Plenum Installation
- VI. Electrical

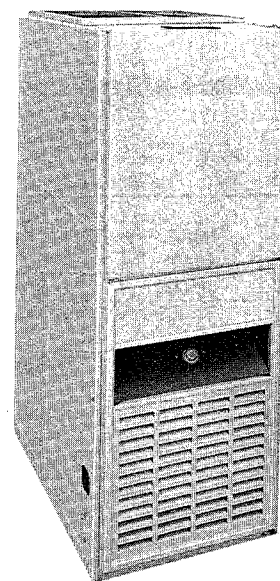

A78593

Fig. 1—Model 58DP

Table 1—Clearances (In Inches)

Sizes	050	075 thru 150
Sides—Single-Wall Vent	1	1
Type-B1 Double-Wall Vent	0	1
Back	0	0
Top of Plenum	1	1
Vent Connector—Single-Wall	6	6
Type-B1 Double-Wall	1	1
Front—Combustion Air*	6	6
Service	30	30

*The 6-inch front clearance is needed for combustion-air entry and drafthood relief.

- VII. Sequence of Operation
- VIII. Filter
- IX. Startup and Adjustment
- X. Care and Maintenance

*To perform these sections (or installation steps), refer to the appropriate sections of "Procedures for Natural-Draft Gas-Fired Furnaces" booklet packaged with this unit.

For accessory installation details, refer to the applicable installation literature.

V. SUPPLY-AIR PLENUM INSTALLATION

A. Installation on a concrete slab

1. See Fig. 2 for dimensions and location of supply-air opening in furnace bottom.

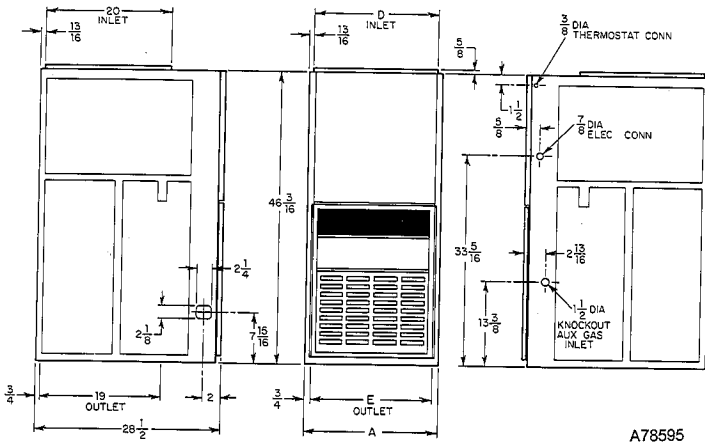

Fig. 2—Dimensional Drawing

Table 2—Dimensions (In Inches)

Size				Vent
050-BA	14 ³ / ₁₆	12 ⁹ / ₁₆	12 ¹ / ₁₆	4
075-AA	17 ¹ / ₂	15 ⁷ / ₈	16	4
075-BA	17 ¹ / ₂	15 ⁷ / ₈	16	4
100-AA	17 ¹ / ₂	15 ⁷ / ₈	16	5
100-BA	17 ¹ / ₂	15 ⁷ / ₈	16	5
125-AA	21	19 ³ / ₈	19 ¹ / ₂	5
125-BA	21	19 ³ / ₈	19 ¹ / ₂	5
150-BA	24 ¹ / ₂	22 ¹³ / ₁₆	23	6

Table 3—Ratings and Performance*

Size	Input Btuh	Capacity Btuh†	Temp Rise Range	Heating		Cooling		Motor HP & Type	Approx Shipping Weight
				Ext Static Pressure	CFM	Ext Static Pressure	CFM		
050-BA	50,000	39,000‡	45—75	0.50	600	0.5	800	1/8-SP	129
075-AA	75,000	58,000	70—100	0.12	630	—	—	1/8-SP	148
075-BA			45—75	0.50	895	0.5	1255	1/8-SP	157
100-AA	100,000	78,000‡	70—100	0.20	850	—	—	1/8-SP	163
100-BA			60—90	0.50	960	0.5	1630	1/2-PSC	170
125-AA	125,000	97,000‡	70—100	0.20	1050	—	—	1/8-SP	187
125-BA			60—90	0.50	1195	0.5	1620	1/2-PSC	187
150-BA	150,000	116,000‡	55—85	0.50	1535	0.5	2075	1/2-PSC	227

*The above ratings are certified for altitudes to 2000 ft. For elevators above 2000 ft, reduce ratings 4% for each 1000 ft above sea level. Refer to National Fuel Gas Code Table F4.

†Determined by U.S. Government tests.

‡Deduct 1000 Btuh for Model 58DR.

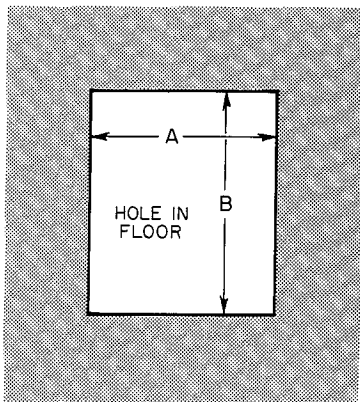

Fig. 3—Floor Opening for Concrete Slab

Table 4—Opening Dimensions

Furnace Casing Width	A	B	
		Heat-Only	Heat/Cool*
14 ³ / ₁₆	13 ¹ / ₈	19 ⁵ / ₈	19 ⁷ / ₁₆
17 ¹ / ₂	16 ⁷ / ₁₆	19 ⁵ / ₈	19 ⁷ / ₁₆
21	19 ⁷ / ₈	19 ⁵ / ₈	19 ⁷ / ₁₆
24 ¹ / ₂	23 ⁷ / ₁₆	19 ⁵ / ₈	19 ⁷ / ₁₆

*These dimensions apply when a Model 28RC or RD Evaporator Coil casing is to be installed.

- Construct hole in floor per dimensions in Fig. 3 and Table 4.
 - Place plenum and furnace as shown in Fig. 4.
- B. Installation on a combustible floor**
- Read Installation Instructions packaged with accessory combustible floor base.
 - Cut and frame hole in floor per dimensions listed in Installation Instructions packaged with combustible floor base. If this requires cutting of a floor joist, tie ends of cut joist into adjacent joists so that proper floor support will be maintained.
 - Assemble and install combustible floor base per instructions packaged with base.
 - When completed, combustible floor base, plenum, and furnace (or coil casing when used) should be installed as shown in Fig. 6.

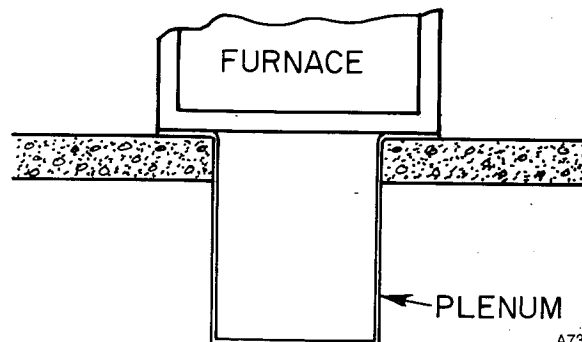

Fig. 4—Furnace on a Concrete Slab

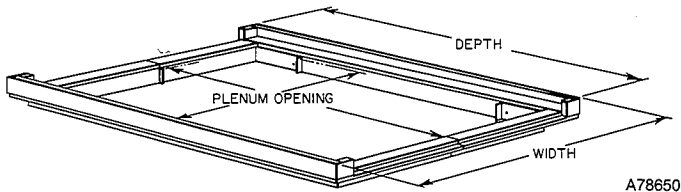

Fig. 5—Combustible Floor Base

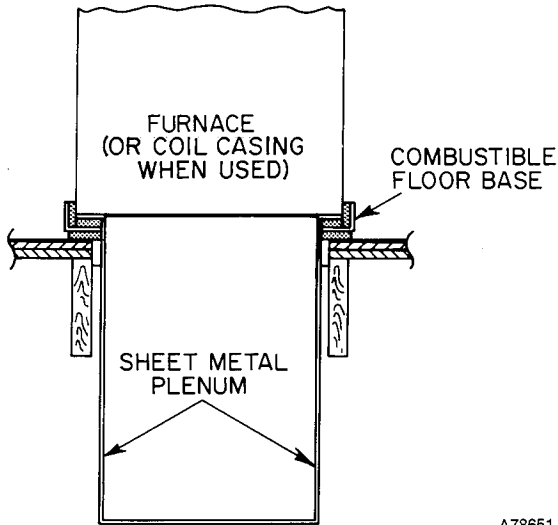

Fig. 6—Furnace, Plenum, and Base Installed on a Combustible Floor

VI. ELECTRICAL CONNECTIONS

A. Line-Voltage Wiring

NOTE: Refer to "Procedures for Natural-Draft Gas Furnaces" (packaged with the equipment) for additional information.

CAUTION

Do not connect aluminum wire between disconnect switch and furnace.

See Fig. 9 for wiring diagram showing the proper field high- and low-voltage wiring.

Use a separate fused branch electrical circuit containing a properly sized fuse or HACR-type circuit breaker for this furnace. A disconnecting means must be located within sight from, and readily accessible to, the furnace. In some areas, the unit door switch may qualify as the disconnecting means.

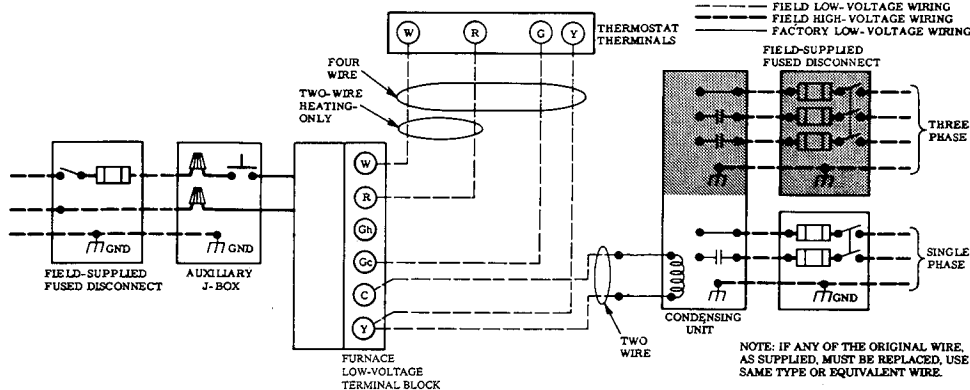

Fig. 9—Heating and Cooling Application Wiring Diagram

WARNING

The cabinet must have an uninterrupted or unbroken ground according to National Electrical Code, ANSI/NFPA 70-1987, or local codes to minimize personal injury if an electrical fault should occur. This may consist of electrical wire or conduit approved for electrical ground when installed in accordance with existing electrical codes. Do not use gas piping as an electrical ground. A failure to adhere to this warning can result in an electrical shock, fire, or death.

If line-voltage wiring to the unit is encased in a nonmetallic sheath, connect the incoming ground wire to the grounding wire inside the furnace J-box. If metallic conduit is used, it will serve as the ground.

B. Low-Voltage Wiring

Make field low-voltage connections at the low-voltage terminal strip. See Fig. 9.

NOTE: Use AWG No. 18 "color-coded" copper thermostat wire for lengths up to 100 ft. Above 100 ft, use AWG No. 16 wire.

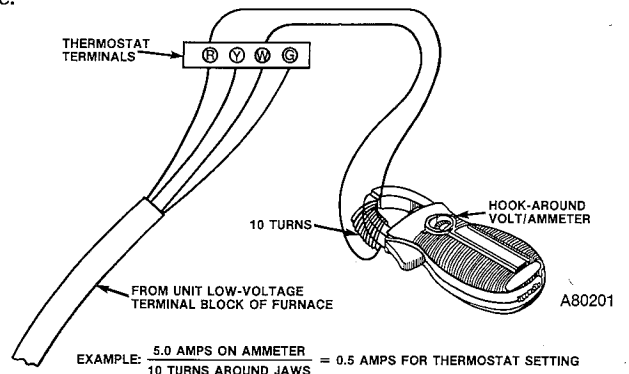

Fig. 7—Amp Draw Check With Ammeter

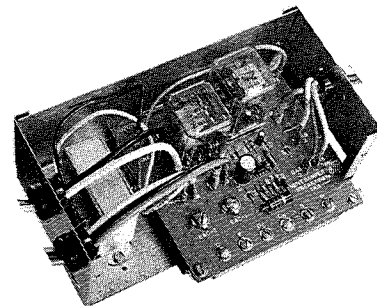

Fig. 8—Printed-Circuit Control Center

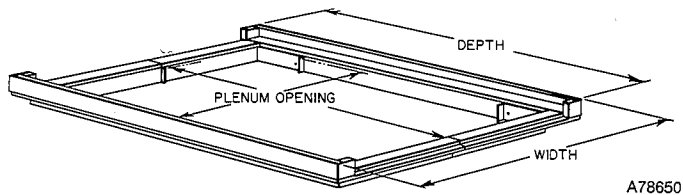

Fig. 5—Combustible Floor Base

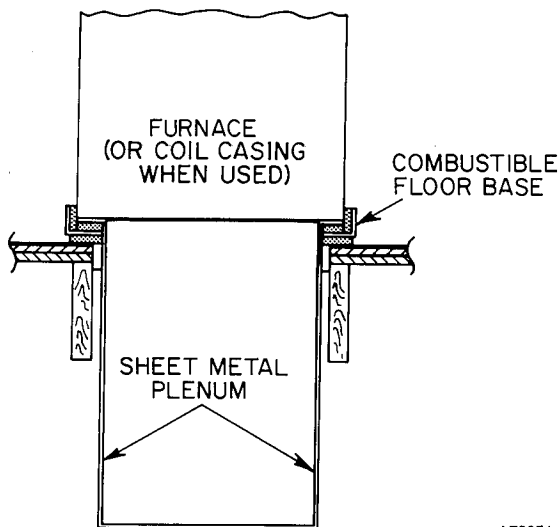

Fig. 6—Furnace, Plenum, and Base Installed on a Combustible Floor

VI. ELECTRICAL CONNECTIONS

A. Line-Voltage Wiring

NOTE: Refer to "Procedures for Natural-Draft Gas Furnaces" (packaged with the equipment) for additional information.

⚠ CAUTION

Do not connect aluminum wire between disconnect switch and furnace.

See Fig. 9 for wiring diagram showing the proper field high- and low-voltage wiring.

Use a separate fused branch electrical circuit containing a properly sized fuse or HACR-type circuit breaker for this furnace. A disconnecting means must be located within sight from, and readily accessible to, the furnace. In some areas, the unit door switch may qualify as the disconnecting means.

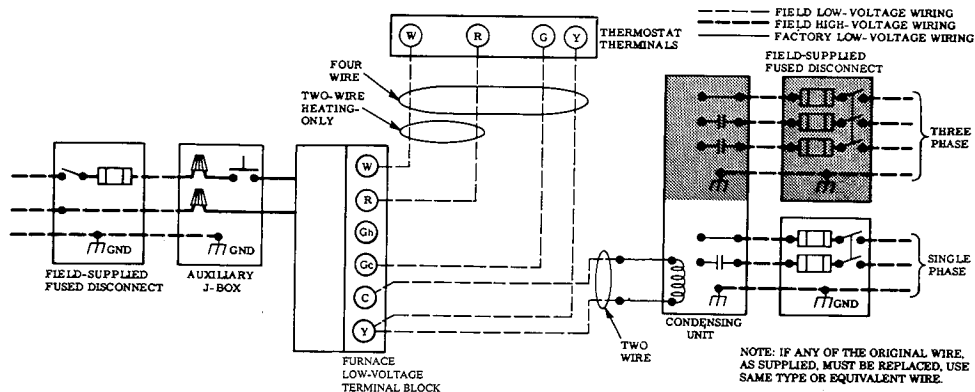

Fig. 9—Heating and Cooling Application Wiring Diagram

⚠ WARNING

The cabinet must have an uninterrupted or unbroken ground according to National Electrical Code, ANSI/NFPA 70-1987, or local codes to minimize personal injury if an electrical fault should occur. This may consist of electrical wire or conduit approved for electrical ground when installed in accordance with existing electrical codes. Do not use gas piping as an electrical ground. A failure to adhere to this warning can result in an electrical shock, fire, or death.

If line-voltage wiring to the unit is encased in a nonmetallic sheath, connect the incoming ground wire to the grounding wire inside the furnace J-box. If metallic conduit is used, it will serve as the ground.

B. Low-Voltage Wiring

Make field low-voltage connections at the low-voltage terminal strip. See Fig. 9.

NOTE: Use AWG No. 18 "color-coded" copper thermostat wire for lengths up to 100 ft. Above 100 ft, use AWG No. 16 wire.

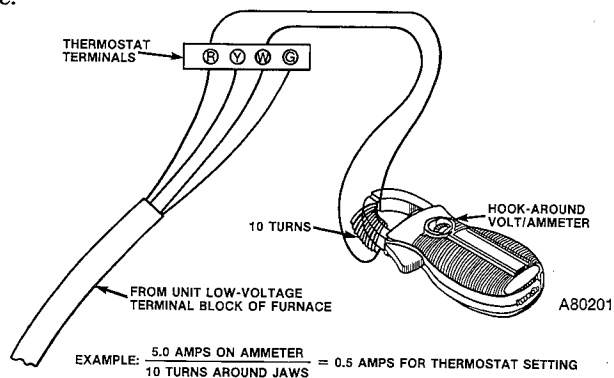

EXAMPLE: 5.0 AMPS ON AMMETER = 0.5 AMPS FOR THERMOSTAT SETTING
10 TURNS AROUND JAWS

Fig. 7—Amp Draw Check With Ammeter

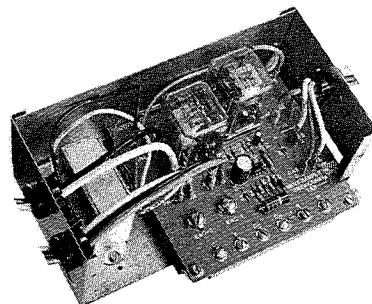
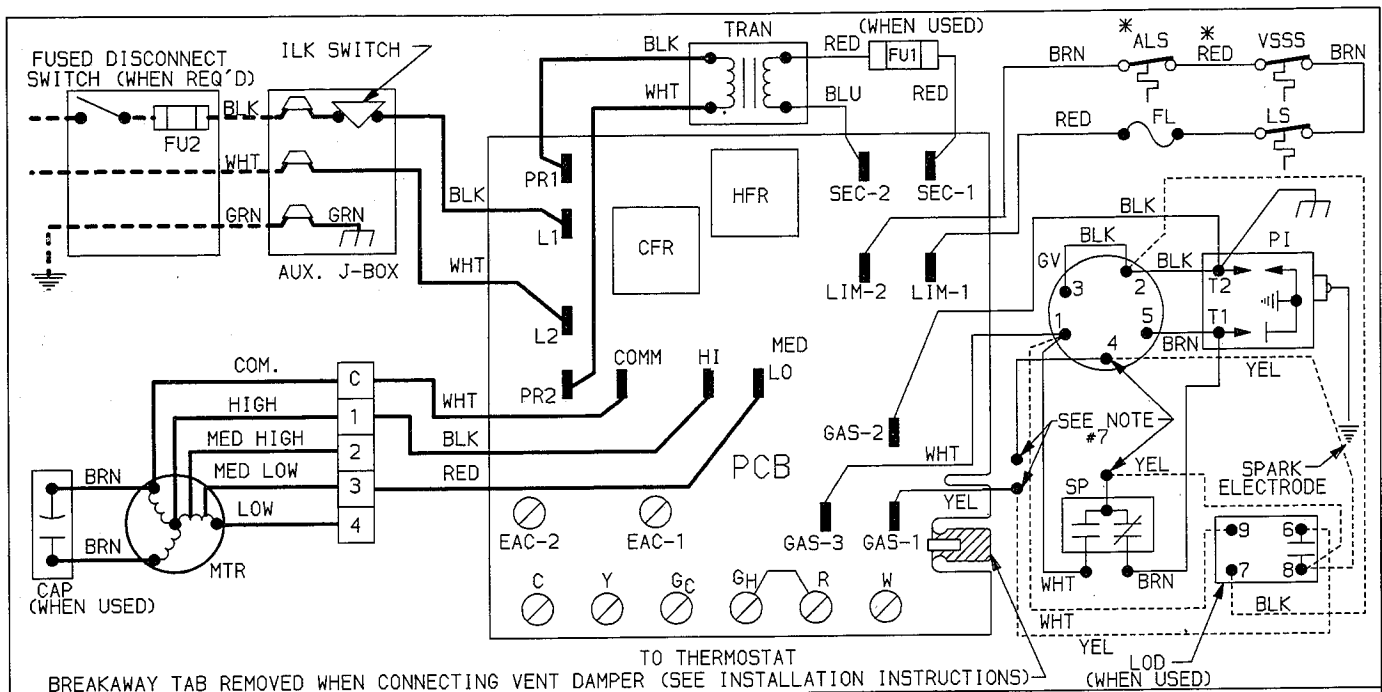

Fig. 8—Printed-Circuit Control Center



BREAKAWAY TAB REMOVED WHEN CONNECTING VENT DAMPER (SEE INSTALLATION INSTRUCTIONS)

NOTES:

- * DOWNFLOW FURNACES ONLY
- 1. HEATING FAN RELAY CONTACT IS NORMALLY CLOSED UNTIL 115V AC IS APPLIED TO FURNACE.
- 2. TO CHANGE MOTOR SPEED, MOVE RED WIRE TO DESIRED SPEED SETTING.
- 3. IF ANY OF ORIGINAL WIRE AS SUPPLIED WITH THE APPLIANCE MUST BE REPLACED, IT MUST BE REPLACED WITH AWM (105°C) WIRE OR ITS EQUIVALENT.
- 4. MOTOR IS THERMALLY OVERLOAD PROTECTED.
- 5. FACTORY SPEED SELECTION IS FOR AVERAGE CONDITIONS, SEE INSTALLATION INSTRUCTIONS FOR OPTIMUM SPEED SELECTION. MOTOR MAY BE 3 OR 4 SPEED.
- 6. SYMBOLS ARE ELECT. REPRESENTATION ONLY.
- 7. FACTORY CONNECTED WHEN ACCESSORY NOT USED.

LEGEND

ALS	AUXILIARY LIMIT SWITCH, MANUAL-RESET (SPST-NC)
CAP	RUN CAPACITOR
CFR	COOLING FAN RELAY (DPDT)
FL	FUSIBLE LINK
FU1	FUSE IN LINE 2 AMP
FU2	FIELD FUSE
GV	GAS VALVE
HFR	HEATING FAN RELAY (SPST-NC)
ILK	SWITCH, BLOW DOOR INTERLOCK (SPST-NO)
LOD	LOCKOUT TIMER DEVICE (SPST-NO)
LS	LIMIT SWITCH, AUTO.-RESET (SPST-NC)
MTR	MOTOR, BLOWER
PCB	PRINTED CIRCUIT BOARD
PI	PILOT IGNITER
SP	SAFETY PILOT (FLAME SENSING)
TRAN	TRANSFORMER
VSSS	VENT SAFETY SHUTOFF SWITCH, MANUAL-RESET (SPST-NC)
	FIELD SPLICE
	PLUG RECEPTACLE
	JUNCTION
	UNMARKED TERMINAL
	TERMINAL PCB FACTORY CONN.
	FACTORY WIRING (120V AC)
	FACTORY WIRING (LOW VOLTAGE)
	FIELD WIRING (120V AC)
	FIELD WIRING (24V AC)
	CONDUCTOR ON PRINTED CIRCUIT BOARD
	SCREW TERMINAL FOR FIELD WIRING
	FIELD GROUND
	EQUIP. GROUND

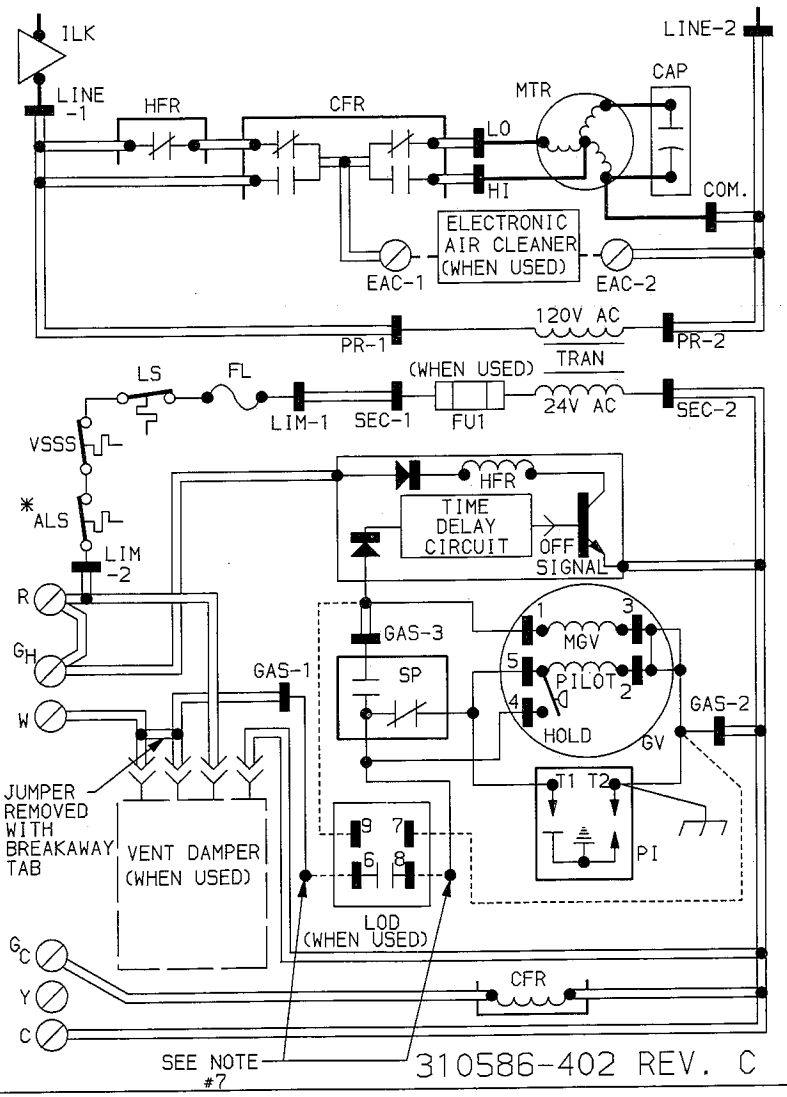
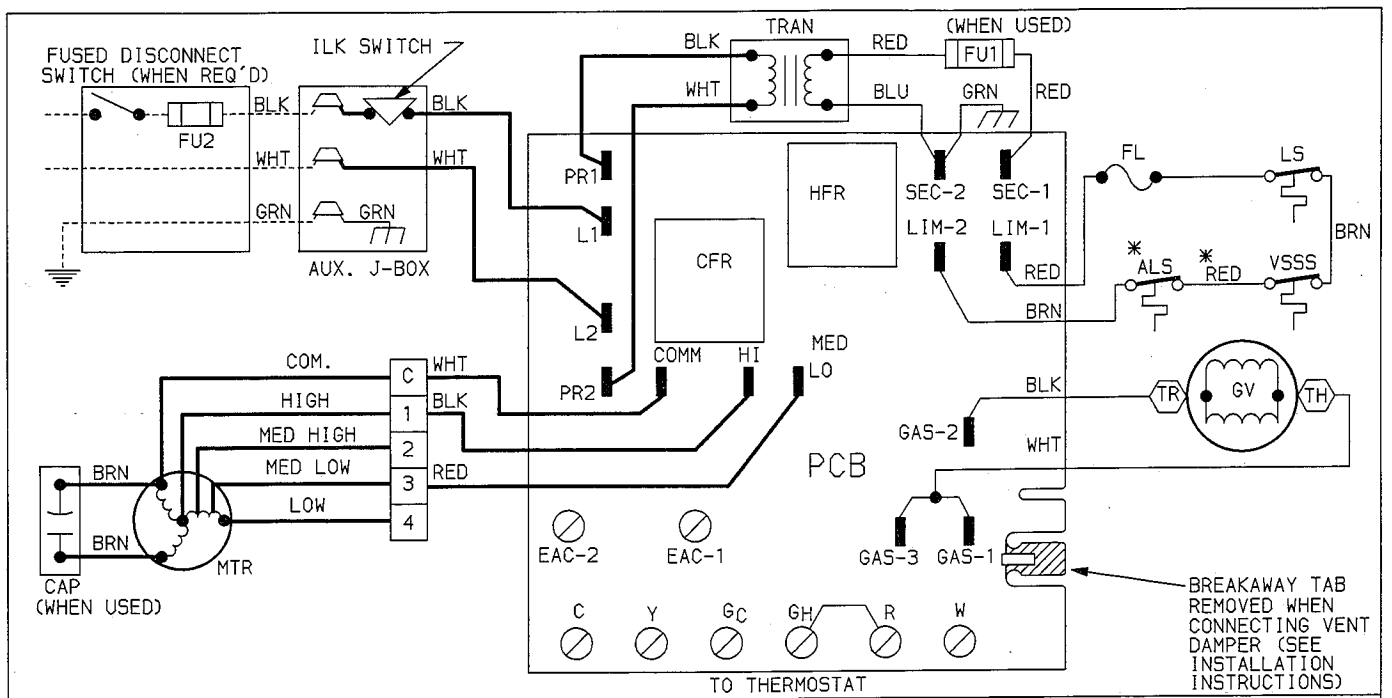

Fig. 10—Wiring Diagram (I/D Pilot)



NOTES:

- * DOWNFLOW FURNACES ONLY
- 1. HEATING FAN RELAY CONTACT IS NORMALLY CLOSED UNTIL 115V AC IS APPLIED TO FURNACE.
- 2. TO CHANGE MOTOR SPEED, MOVE BLK OR RED WIRE TO DESIRED SPEED SETTING.
- 3. IF ANY OF ORIGINAL WIRE AS SUPPLIED WITH THE APPLIANCE MUST BE REPLACED, IT MUST BE REPLACED WITH AWM (105°C) WIRE OR ITS EQUIVALENT.
- 4. MOTOR IS THERMALLY OVERLOAD PROTECTED.
- 5. FACTORY SPEED SELECTION IS FOR AVERAGE CONDITIONS, SEE INSTALLATION INSTRUCTIONS FOR OPTIMUM SPEED SELECTION. MOTOR MAY BE 3 OR 4 SPEED.
- 6. SYMBOLS ARE AN ELECTRICAL REPRESENTATION ONLY.

LEGEND

- | | |
|------|--|
| ALS | AUXILIARY LIMIT SWITCH, MANUAL-RESET (SPST-NC) |
| CAP | RUN CAPACITOR |
| CFR | COOLING FAN RELAY (DPDT) |
| FL | FUSIBLE LINK |
| FU1 | FUSE IN LINE 2 AMP |
| FU2 | FIELD FUSE |
| GV | GAS VALVE |
| HFR | HEATING FAN RELAY (SPST-NC) |
| ILK | SWITCH, BLOWER DOOR INTERLOCK (SPST-NO) |
| LS | LIMIT SWITCH, AUTOMATIC-RESET (SPST-NC) |
| MTR | MOTOR, BLOWER |
| PCB | PRINTED CIRCUIT BOARD |
| TRAN | TRANSFORMER |
| VSSS | VENT SAFETY SHUTOFF SWITCH, MANUAL-RESET (SPST-NC) |
-
- | | |
|--|------------------------------------|
| | FIELD SPLICE |
| | PLUG RECEPTACLE |
| | JUNCTION |
| | MARKED TERMINAL |
| | UNMARKED TERMINAL |
| | TERMINAL PCB FACTORY CONN. |
| | FACTORY WIRING (120V AC) |
| | FACTORY WIRING (LOW VOLTAGE) |
| | FIELD WIRING (120V AC) |
| | CONDUCTOR ON PRINTED CIRCUIT BOARD |
| | SCREW TERMINAL FOR FIELD WIRING |
| | FIELD GROUND |
| | EQUIP. GROUND |

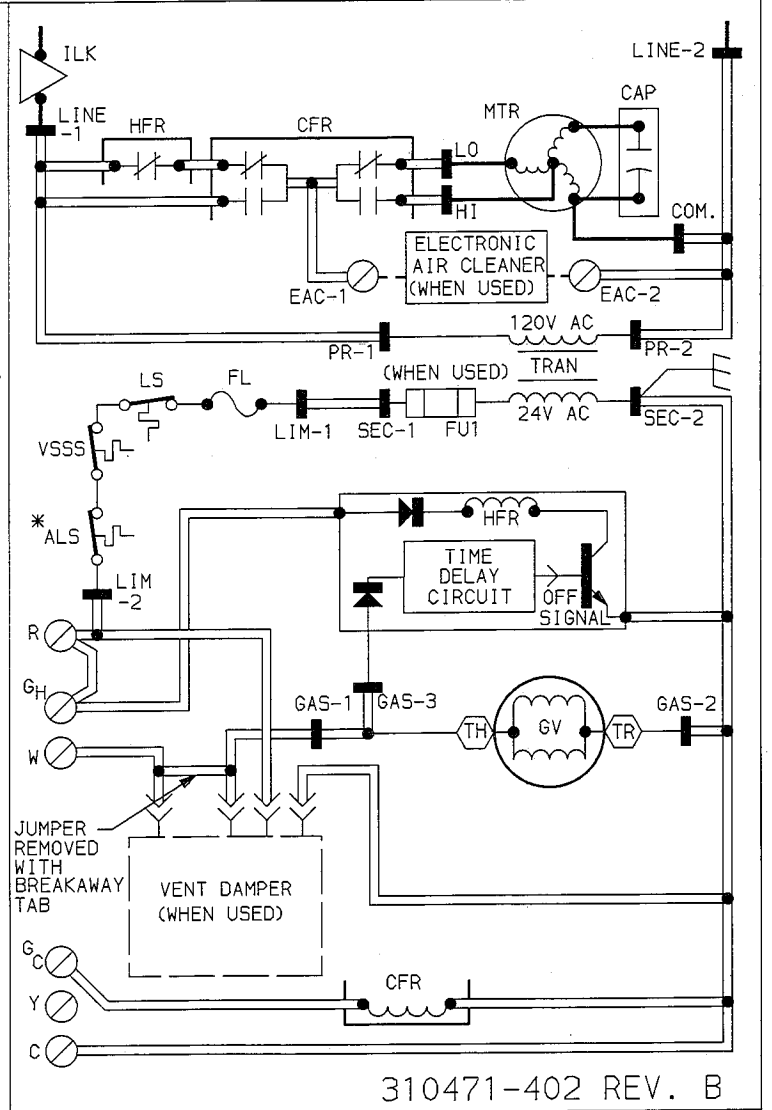

Fig. 11—Wiring Diagram (Match-lit Pilot)

IMPORTANT: The thermostat heat anticipation must be set to match the amp draw of the gas valve and electrical components in the R-W circuit. Accurate amp draw readings can be obtained at thermostat subbase terminals R & W. Fig. 7 illustrates an easy method for obtaining the actual amp draw.

The room thermostat should be located where it will be in the natural circulation path of room air. Avoid locations where the thermostat would be exposed to cold-air infiltration, drafts from windows, doors, or other openings leading to the outside, or exposure to air currents from warm- or cold-air registers; or to exposure where the natural circulation of the air is cut off—such as behind doors, above or below mantels, shelves, etc.

The thermostat should not be exposed to heat from nearby fireplaces, radios, televisions, lamps, or rays from the sun. Nor should the thermostat be mounted on a wall containing pipes or warm-air ducts, or a flue or vent that could affect its operation and prevent it from properly controlling the room temperature. Any hole in the plaster or panel through which the wires pass from the thermostat should be adequately sealed with suitable material to prevent drafts from affecting the thermostat.

C. Blower Control Center

Each furnace features a printed-circuit control center. This will aid the installer and serviceman when installing and servicing the unit. See Fig. 8. A low-voltage terminal board is marked for easy connection of field wiring.

VII. SEQUENCE OF OPERATION

NOTE: The wiring diagrams shown in Figs. 10 and 11 cover heating/cooling units.

A. Heating

Gas and electrical supplies must be turned on at the furnace.

NOTE: When power is applied to heat relay coil HFR in the control circuit, the normally closed contacts in the blower circuit will open.

1. White Rodgers 36E Gas Valve (IID Models). See Fig. 10.

When the thermostat "calls for heat," the control circuit is closed between terminals R and W. Power from transformer TRAN through fusible link FL, limit switches LS & ALS and vent safety shut-off switch VSSS, energizes the pilot valve part of automatic gas valve GV and pilot igniter PI. The pilot valve opens, permitting gas flow to the pilot burner where it is ignited.

The pilot valve portion of automatic gas valve GV has a "pick" solenoid coil and latching "hold" device. The "pick" coil must be energized to open the pilot valve, but only the "hold" device must be energized to keep it open.

The "hold" device varies with the gas valve design used on the furnace. It could be an internal pressure switch in series with the "pick" solenoid coil, an internal electrical resistor in series with the solenoid "pick" coil, or a separate electrical solenoid coil.

When the pilot flame is established, safety pilot SP switches its contacts in approximately 40 to 60 seconds, energizing the main valve portion of gas valve GV and deenergizing safety pilot igniter SP and the "pick" coil of the pilot solenoid portion in gas valve GV. The pilot valve is held open by the "hold" device within gas valve GV.

The main valve portion of gas valve GV has a delayed opening operator that opens within 6 to 15 seconds after it is energized, permitting gas flow to the main burners where the gas is ignited by pilot SP.

2. Honeywell VR 800A Gas Valve (Match-Lit Models). See Fig. 11

The furnace pilot must be lit to energize the thermal magnet circuit of gas valve GV, thus permitting gas flow to the remaining portion of the valve.

When the thermostat "calls for heat," the control circuit is closed between terminals R and W. Power from transformer TRAN through fusible link FL, limit switch LS & ALS and vent safety shut-off switch VSSS energizes gas valve GV, causing the valve to open and permitting gas flow to the main burners, where it is ignited by the pilot.

3. Blower Circuit

With power through the solid-state time-delay circuit on printed-circuit board PCB and heat relay HFR, blower motor MTR is energized on heating speed approximately 75 seconds after gas valve GV has been energized (or the pilot flame has been proven in the case of IID systems).

4. Limit Control

If the furnace overheats for any reason, limit control LS switches, breaking the circuit to automatic gas valve GV. The gas valve closes immediately, stopping gas flow to the main burners and the pilot. In addition, blower motor MTR continues to operate because heat relay HFR is deenergized to cool down the furnace.

Manual reset auxiliary limit switch ALS is located on the top right-hand corner of the furnace. In the event of blower motor failure, this switch breaks the electrical circuit to the gas valve, stopping gas flow to the main burners. The switch must be manually reset after the blower motor has been replaced.

Fusible link FL is provided in the transformer TRAN secondary circuit as protection from overheating conditions in the vestibule area of the furnace. Should this condition exist, the fuse opens and deenergizes gas valve GV and heat relay HFR, stopping the gas flow to the burners and starting blower motor MTR.

When the thermostat is satisfied, the circuit between R and W is broken, deenergizing automatic gas valve GV, pilot SP (when used), and the solid-state time-delay circuit on printed-circuit board. The gas flow stops immediately to the pilot and main burners with the IID controls, and to the main burners only with standing pilot controls. After approximately 105 seconds, heat relay HFR is energized and blower motor MTR stops.

5. Vent Safety Shut-off System Switch

The purpose of this control is to safely shutdown the furnace if a blocked vent condition occurs.

During a blocked vent condition, temperature in the draught hood opening will rise causing vent safety shut-off switch to open, breaking the circuit to gas valve GV. The gas valve closes immediately, stopping gas flow to the main burners and pilot, and the blower will run continuously.

The furnace will remain in this mode until the vent safety shut-off system switch is manually reset.

B. Vent Damper (When Used)

With gas and electrical power supplied to the furnace, the vent damper motor is deenergized, and the vent damper is closed until the thermostat "calls for heat."

On a "call for heat" by the thermostat, the vent damper motor is energized and the damper opens. When the vent damper reaches the full-open position, the damper motor is deenergized and a circuit is completed to the main gas valve via the pilot. At this time, the main gas valve is energized and the main burners are ignited; the vent damper will

remain open until the thermostat is satisfied.

When the thermostat is satisfied, it will deenergize the main gas valve and stop the gas flow. The vent damper motor will energize and close the damper. When the vent damper reaches the full-closed position, the damper motor is deenergized and will remain so until the next "call for heat" by the thermostat.

C. Cooling (Cooling Models Only)

When the thermostat "calls for cooling," power from transformer TRAN energizes the condensing unit contactor, cooling relay coil CFR, closing its contacts and energizing blower motor MTR on its cooling speed. It continues to operate until the thermostat is satisfied.

When the thermostat is satisfied, the circuit to terminal Gc is broken, deenergizing cooling relay coil CFR which, in turn, opens its contacts, stopping blower motor MTR.

VIII. FILTER ARRANGEMENT

The two factory-supplied filters are shipped in the blower compartment. After the return-air duct has been connected to the furnace, install the filters in a V-formation inside the return-air plenum. See Fig. 12.

⚠ WARNING
Never operate the unit without a filter or with the filter access door removed. A failure to adhere to this warning can cause a fire, physical injury, or death.

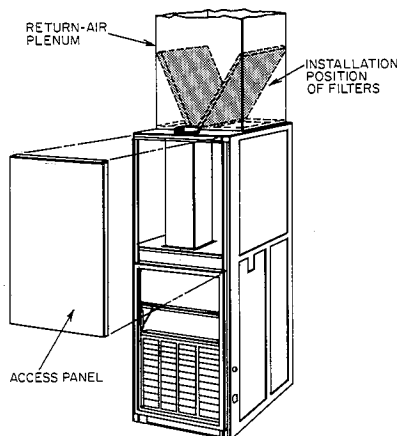

Fig. 12—Position of Filters

IX. STARTUP AND ADJUSTMENT

In addition to the following information, refer to "Procedures for Natural-Draft Gas-Fired Furnaces" packaged with the unit.

NOTE: There is a switch located in the blower compartment that breaks the electrical power supply when the blower access door is removed. Be sure the blower access door is properly installed.

⚠ CAUTION
This furnace is equipped with a fusible link in the vestibule area that will melt if an overheating condition caused by an inadequate combustion-air supply or improper venting practices develops. Do not jumper this fuse. Correct the condition and replace the fuse with an identical part.

The gas service pressure must not exceed 0.5 psig (14 in. wc).

NOTE: The gas valve regulator has been nominally-set at 3.5 in. wc for natural gas. Refer to "Procedures for Natural-Draft Gas Furnace Installation" for readjusting when checking input.

A. Adjustment of Blower Speed

⚠ WARNING
Disconnect the electrical power before changing the speed tap. A failure to adhere to this warning can cause personal injury.

To change motor speed taps, remove the motor tap lead (See Table 5.) and relocate it on the desired terminal on the plug-in terminal block/speed selector located on the blower.

⚠ CAUTION
When adjusting the blower speed, make certain that the temperature rise across the heat exchanger does not exceed that specified on the rating plate.

Table 5—Speed Selector

Speed	Tap No.*†
Common	C
Hi	1
Med-Hi	2
Med-Low	3
Low	4

*Furnaces without a cooling fan relay are equipped with a 3-speed motor.

†White wire from control box to common; black wire from control box to cooling speed selection (when used); red wire from control box to heating speed selection.

B. Automatic Gas Control Valve

These units are equipped with an automatic gas control valve. If not already checked when lighting the main burner, check the proper operation of this valve by moving the room thermostat pointer above and below room temperature and observing that the main burners light on "call for heat" and go off when the pointer is moved below room temperature setting.

NOTE: For ease of adjusting the pilot flame, disconnect terminal No. 1 at the gas valve. This will prevent main burner ignition and allow time to adjust the pilot. Reconnect the power lead after adjustment.

X. CARE AND MAINTENANCE

⚠ CAUTION
Because of possible damage to the equipment or personal injury, maintenance should be performed by qualified persons only.

⚠ WARNING
Never store anything on, or in contact with, the furnace, such as:

1. Spray or aerosol cans, rags, brooms, dust mops, vacuum cleaners, or other cleaning tools.
2. Soap powders, bleaches, waxes or other cleaning compounds, plastic or plastic containers, gasoline, kerosene, cigarette lighter fluid, dry cleaning fluids, or other volatile fluids.
3. Paint thinners and other painting compounds, paper bags or other paper products.

A failure to adhere to this warning can cause corrosion of the heat exchanger and vent system, fire, personal injury, or death.

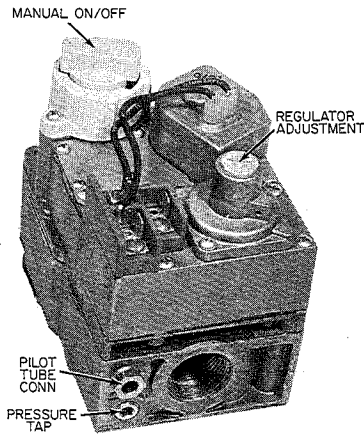

Fig. 13—Honeywell Model VR 800A

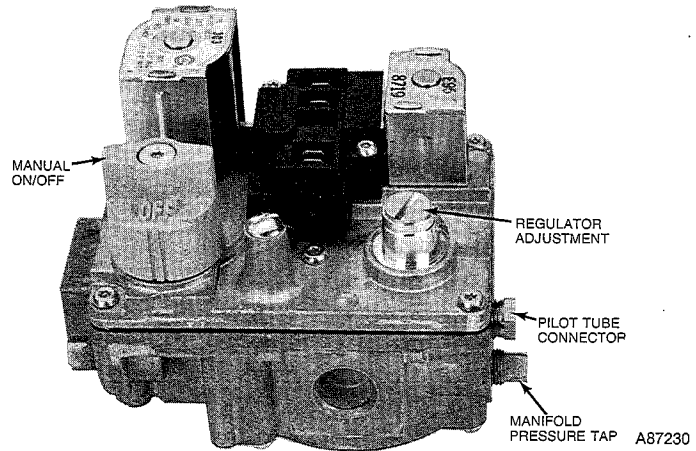

Fig. 14—White Rodgers Model 36E

For continuing high performance, and to minimize possible equipment failure, it is essential that periodic maintenance be performed on this equipment. Consult your local Dealer as to the proper frequency of maintenance and the availability of a maintenance contract.

The ability to properly perform maintenance on this equipment requires certain mechanical skills and tools. If you do not possess these, contact your Dealer for maintenance.

⚠ WARNING

Turn off the gas and electrical supplies to the unit before performing any maintenance or service it. Follow the relighting instructions on the label attached to the furnace. A failure to adhere to this warning can cause personal injury.

The minimum maintenance that should be performed on the equipment is as follows:

1. Check and clean or replace air filter each month or as required.
2. Check blower motor and wheel for cleanliness and lubrication each heating and cooling season. Clean and lubricate as necessary.
3. Check electrical connections for tightness and controls for proper operation each heating season. Service as necessary.

⚠ WARNING

As with any mechanical equipment, personal injury can result from sharp metal edges, etc.; therefore, be careful when removing parts.

A. Air Filter

Each furnace accommodates two filters which can be installed above the furnace in the return-air plenum. See Fig. 12.

To clean or replace the filters, proceed as follows:

1. Disconnect electrical power before removing access panel.
2. Remove upper access panel.
3. Reach up behind top plate, tilt filters toward center of return-air plenum, remove filters, and replace or clean as needed.

4. Some furnaces are equipped with permanent, washable filters. Clean those filters as follows:
 - a. Clean with tap water.
 - b. Rinse and let dry. No oiling or coating of filters is required.
 - c. Reinstall filters with cross-hatch binding facing blower.

B. Blower Motor Wheel

Clean and lubricate as follows:

1. Remove upper access panel.
2. Loosen screw in vent pipe enclosure front and remove vent enclosure front by sliding forward (toward front of unit).
3. Disconnect vent pipe at first joint above unit and swing vent pipe assembly to side, supported by suitable means (block of wood, etc.).
4. Slide vent pipe upward through rectangular opening in top plate and remove vent pipe from furnace.
5. Remove four screws in vent pipe enclosure back, and remove enclosure back by tilting top toward blower and sliding bottom toward front of furnace.
6. Disconnect electrical leads from right side of motor speed selector. Note location of wires for reassembly.
7. Remove screws holding blower assembly against blower deck and slide blower assembly out of furnace.
8. Squeeze side tabs of motor speed selector and pull it from blower housing.

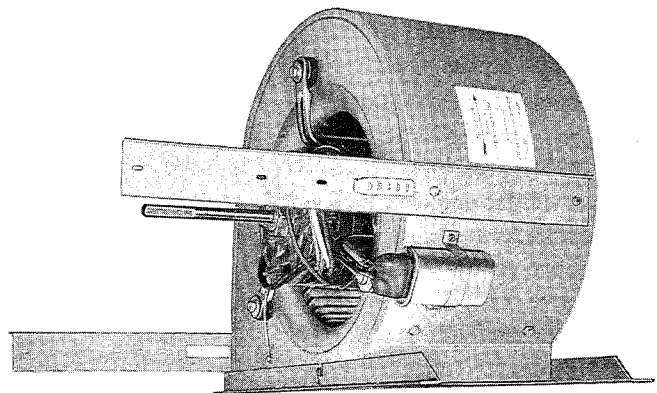

Fig. 15—Dual Blower With Left-Hand Housing and Wheel Removed

A77007

9. Units with motor capacitor, loosen screw in strap holding capacitor to blower housing and slide capacitor from under strap.
10. Mark blower wheel, motor, and motor support in relation to blower housing before disassembly, to insure proper reassembly.
11. Loosen setscrew holding blower wheel onto motor shaft.
12. Remove bolts holding motor mount to blower housing and slide motor and mount out of housing. Some motors have a ground wire attached to blower housing; disconnect it also.
13. Lubricate motor.
 - a. Remove dust caps or plugs from oil ports located at each end of motor.
 - b. Use good grade of SAE 20 nondetergent motor oil and put one teaspoon, 5cc, 3/16 oz., or 16 to 25 drops in each oil port.
 - c. Allow time for total quantity of oil to be absorbed by each bearing.
 - d. After oiling motor, be sure to wipe excess oil from motor housing.
 - e. Replace dust caps or plugs on oil ports.
14. Remove blower wheel from housing.
 - a. Mark blower wheel orientation and cutoff location to insure proper reassembly.
 - b. Remove screws holding cutoff plate and remove cutoff plate from housing.
 - c. Lift blower wheel from housing through opening.
15. Clean blower wheel and motor by using vacuum with soft brush attachment. Care must be exercised not to disturb balance weights (clips) on blower wheel vanes. Also do not drop or bend wheel, as balance will be affected.
16. Reassemble blower by reversing procedures 14a thru 14c. Be sure wheel is positioned for proper rotation.
17. Reassemble motor and blower by reversing procedures 8 thru 12. If motor has ground wire, be sure it is connected as before. Be sure the blower wheel setscrew is on the flat of the motor shaft when tightening the setscrew.
18. Reinstall blower assembly in furnace.
19. Reinstall vent enclosure back.
20. Reinstall vent pipe through opening in top plate, secure to drafthood and connect remainder of vent pipe assembly.
21. Reinstall vent enclosure front, and secure with screw.
22. Reinstall access panel.

C. Cleaning Heat Exchanger

If it becomes necessary to clean the heat exchanger because of carbon deposits, soot, etc., proceed as follows:

1. Turn off gas and electrical supply to furnace.
2. Remove front access doors.
3. Remove vent pipe enclosure front and flue pipe.
4. Remove draft diverter. Screws are located inside draft diverter opening.
5. Remove flue baffles from flue outlets of heat exchanger.

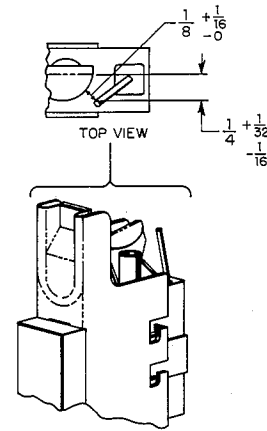

A79080

Fig. 16—Position of Electrode to Pilot

6. Remove secondary-air shield and burners. To remove pilot burner, disconnect pilot supply tube (and thermocouple on 100% shut-off models) at gas valve.
7. Clean flue ways with brush and or vacuum. Check heat exchanger for leaks and cracks. Replace if necessary.
8. Replace flue baffles. Be sure all screws are in place and tight.
9. Replace draft diverter and vent connector. Be sure screws are replaced and tight.
10. Using vacuum cleaner with soft brush attachment, clean burners. After cleaning, replace burners and secondary-air shield.
11. Turn on gas and electricity. Check for gas leaks.

▲ WARNING

Never use a match or other open flame to check for gas leaks. Use a soap-and-water solution. A failure to adhere to this warning can cause an explosion, fire, personal injury, or death.

D. Pilot

Check the pilot and clean if necessary at the beginning of each heating season. The pilot flame should be high enough for proper impingement of the safety element and to light the burners. Remove the accumulation of soot and carbon from the thermocouple safety element or sensing probe.

E. Electrical Controls and Wiring

NOTE: There may be more than one electrical supply to unit.

With power disconnected to unit, check all electrical connections for tightness. Tighten any screws or electrical connections. If any smoky or burned connections are noticed, disassemble the connection, clean all parts, and stripped wire, and reassemble properly and securely. Electrical controls are difficult to check without proper instrumentation; therefore, reconnect electrical power to unit and observe unit through one complete operating cycle. If there are any discrepancies in the operating cycle, contact your Dealer and request service.