

This vertical design N-coil is a furnace coil designed to provide the highest standards of reliability and durability. The product is offered in a painted cased (CK5A) or an embossed cased (CK5B) version. The cased coils are offered in standard, overhang, and wide configurations for use in multiple installation applications. Additionally, the cased coils are offered in a Transition configuration, which is designed to fit two furnace widths without field modification.

Easy maintenance is provided as the coil slides out of the cabinet after removing the access door and service panel.

The coils are available in sizes 018 through 060 (1-1/2-5 tons).

COMMON FEATURES

Water Management—The CK coil design does an excellent job of water management. The coils are designed to avoid water blow-off into the ducts by directing condensate away from the fins and into the drain pan. The coils drain pan design provides improved condensate removal into the drain. This improves indoor air quality.

Durable Condensate Pan—Each coil is equipped with a corrosion resistant condensate drain pan. The condensate drain pan is designed with a slope to help ensure proper drainage, improved moisture removal, and home comfort.

Compact Design—Unique design offers as much as 2 in. less in height to aid in tight installations.

Brass Inserts—Every condensate pan features two 3/4 in. female threaded brass insert connections. The Bryant unique brass inserts provide for a leak-free condensate line connection to prevent water damage.

Refrigerant Connections—The coils are provided with proven sweat-connections for leak-free operation maintaining system reliability.

Burst Pressures—These coils meet or exceed burst pressure of 2100 psi which is at least three to five times the pressure they will see in actual application.

External Piston Location—Provides easy access to the piston metering device, for quick installations and standard service procedures.

Liquid Line Bracket—Holds the piston body in place for quick, safe piston access without needing a back-up wrench.

Neoprene Ring—The ring, installed inside the liquid line connection, is the best option for preventing refrigerant leaks and future service calls. Neoprene works with both Puron® and R-22 Refrigerant.

Protective Tube Sheets—Protect the durable copper tubing from being damaged during the manufacturing and installation process.

Warranty—All Bryant coils feature a 1-year limited warranty on parts, with additional extended warranties available for the system.

MODEL NUMBER NOMENCLATURE

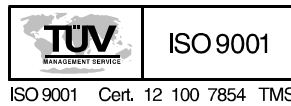
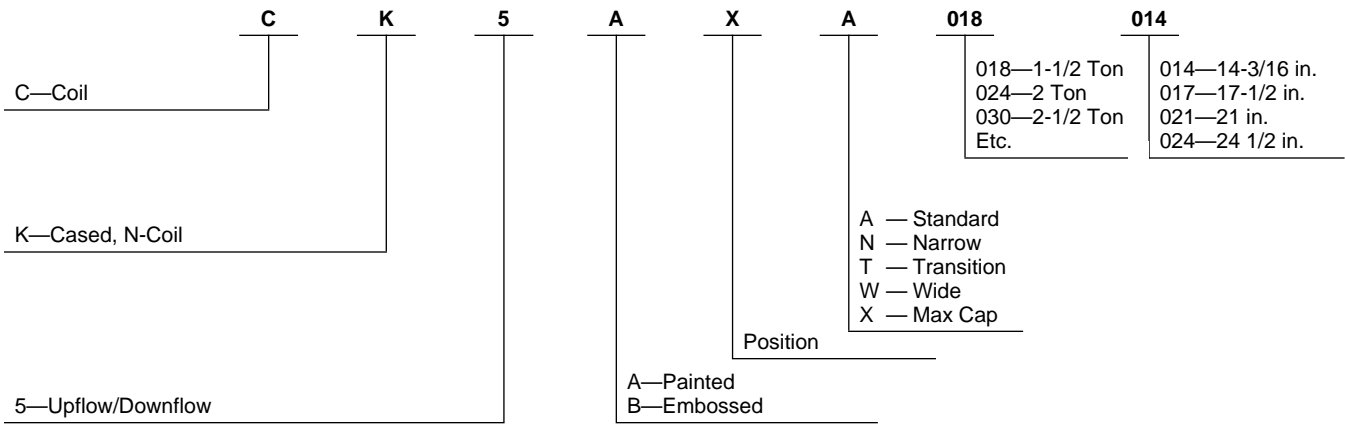

CERTIFICATION APPLIES ONLY WHEN
USED WITH PROPER COMPONENTS
AS LISTED WITH ARI

NOTE: 1. Series designation is the 14th position of unit model number.

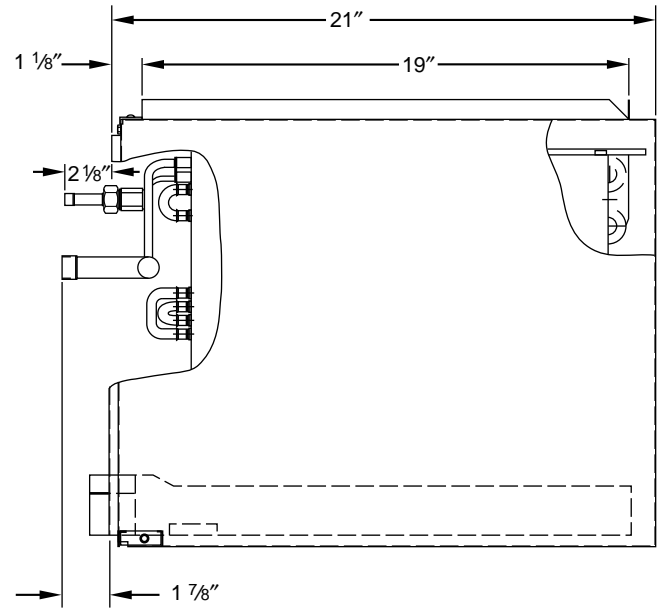
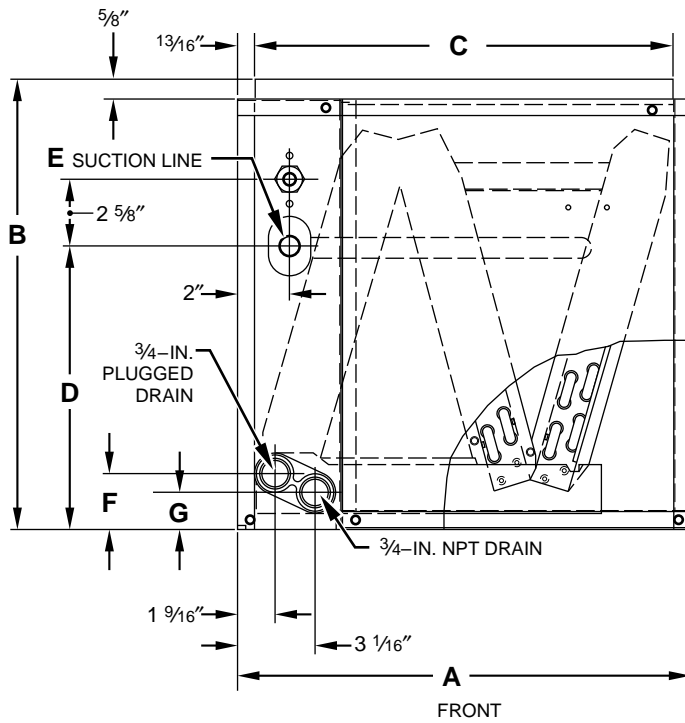

RIGHT SIDE

A97606

DIMENSIONS (In.)

UNIT	SERIES	A	B	C	D	E	F	G	SHIPPING WEIGHT (LB)
CK5(A,B)XA018014*	A	14-3/16	13-1/4	12-9/16	5	5/8	2-1/8	1-3/8	28-1/2
CK5(A,B)XA024014*	A	14-3/16	13-1/4	12-9/16	7-1/16	5/8	2-1/8	1-3/8	32
CK5(A,B)XW024017	A	17-1/2	13-1/4	15-7/8	6-11/16	5/8	2-1/8	1-3/8	33
CK5(A,B)XA030014*	A	14-3/16	15-1/4	12-9/16	9-1/16	3/4	2-1/8	1-3/8	35-1/2
CK5(A,B)XW030017	A	17-1/2	15-1/4	15-7/8	8-13/16	3/4	2-1/8	1-3/8	37-1/2
CK5(A,B)XA036017*	B	17-1/2	17-5/8	15-7/8	10-13/16	3/4	2-1/8	1-3/8	43
CK5(A,B)XN036014	B	14-3/16	17-5/8	12-9/16	11-3/16	3/4	2-1/8	1-3/8	40
CK5(A,B)XT036017*	A	17-1/2	19-7/16	15-7/8	13-1/16	3/4	4-3/8	3-5/8	49
CK5(A,B)XW036021	B	21	17-5/8	19-3/8	10-1/2	3/4	2-1/8	1-3/8	44
CK5(A,B)XA042021*	B	21	17-5/8	19-3/8	10-1/2	7/8	2-1/8	1-3/8	44
CK5(A,B)XN042017	B	17-1/2	17-5/8	15-7/8	10-7/8	7/8	2-1/8	1-3/8	43
CK5(A,B)XT042021*	A	21	19-7/16	19-3/8	12-3/4	7/8	4-3/8	3-5/8	52
CK5(A,B)XA048021*	B	21	19-5/8	19-3/8	12-11/16	7/8	2-1/8	1-3/8	47-1/2
CK5(A,B)XN048017	B	17-1/2	19-5/8	15-7/8	12-15/16	7/8	2-1/8	1-3/8	45-1/2
CK5(A,B)XT048021*	A	21	21-3/8	19-3/8	14-15/16	7/8	4-3/8	3-5/8	56
CK5(A,B)XW048024	B	24-1/2	19-5/8	22-7/8	12-3/16	7/8	2-1/8	1-3/8	49-1/2
CK5(A,B)XA060024*	A	24-1/2	22-5/8	22-7/8	16-1/2	7/8	2-1/8	1-3/8	62
CK5(A,B)XN060021	A	21	26-15/16	19-3/8	14-3/8	7/8	2-1/8	1-3/8	67
CK5(A,B)XT060024*	A	24-1/2	24-7/8	22-7/8	18-3/4	7/8	4-3/8	3-5/8	69
CK5(A,B)XX060024	A	24-1/2	26-15/16	22-7/8	14-1/4	7/8	2-1/8	1-3/8	70

* In these models the coil can be removed from the casing and installed as an uncased coil without needing to field fabricate the coil enclosure to prevent air bypass.

GROSS COOLING CAPACITIES (MBH)

UNIT SIZE	INDOOR COIL AIR		SATURATED TEMPERATURE LEAVING EVAPORATOR (°F)														
			30			35			40			45			50		
	CFM	EWB	TC	SHC	BF	TC	SHC	BF	TC	SHC	BF	TC	SHC	BF	TC	SHC	BF
A018	450	72	31.9	14.8	0.00	28.9	13.4	0.00	26.0	12.1	0.00	22.6	10.7	0.07	18.5	9.04	0.06
		67	26.8	15.8	0.07	23.7	14.3	0.06	20.5	12.8	0.05	16.7	11.2	0.04	12.5	9.40	0.05
		62	21.8	16.6	0.04	18.6	14.9	0.04	15.4	13.3	0.05	12.3	11.7	0.08	9.95	9.95	0.18
	600	72	37.5	17.3	0.00	34.0	15.8	0.00	30.5	14.2	0.16	26.5	12.6	0.11	22.1	10.9	0.09
		67	31.3	18.7	0.10	27.8	17.1	0.09	24.3	15.5	0.08	20.1	13.7	0.07	15.2	11.7	0.09
		62	25.8	20.1	0.08	22.2	18.4	0.08	18.6	16.6	0.08	15.2	14.7	0.11	12.5	12.5	0.22
	750	72	41.7	19.2	0.00	37.9	17.6	0.00	34.0	16.0	0.17	29.6	14.2	0.14	24.7	12.4	0.12
		67	35.1	21.2	0.13	31.0	19.5	0.12	26.9	17.7	0.11	22.6	15.9	0.11	17.4	13.7	0.12
		62	28.4	22.9	0.10	24.9	21.3	0.10	21.4	19.6	0.11	17.7	17.5	0.14	14.8	14.8	0.26
A024 W024	600	72	38.7	17.9	0.00	35.4	16.4	0.00	32.0	15.0	0.13	28.1	13.3	0.08	23.7	11.6	0.07
		67	32.6	19.5	0.07	29.1	17.9	0.06	25.6	16.3	0.06	21.5	14.5	0.05	16.6	12.5	0.06
		62	27.0	20.9	0.05	23.4	19.2	0.05	19.8	17.4	0.05	16.2	15.5	0.08	13.3	13.3	0.18
	800	72	44.0	20.4	0.21	40.4	18.9	0.17	36.8	17.3	0.13	32.4	15.6	0.11	27.2	13.7	0.10
		67	37.4	22.8	0.10	33.5	21.1	0.10	29.5	19.4	0.09	25.0	17.5	0.08	19.7	15.4	0.09
		62	30.6	25.0	0.07	27.0	23.2	0.08	23.4	21.4	0.09	19.7	19.3	0.12	16.6	16.6	0.23
	1000	72	47.9	22.3	0.18	44.0	20.7	0.17	40.1	19.2	0.16	35.5	17.4	0.14	30.0	15.4	0.13
		67	40.7	25.5	0.13	36.6	23.8	0.13	32.4	22.0	0.12	27.3	20.0	0.11	21.9	17.9	0.12
		62	33.7	28.6	0.10	30.0	26.7	0.11	26.2	24.9	0.12	22.7	22.5	0.17	19.4	19.4	0.28
A030 W030	750	72	54.4	25.3	0.00	48.7	22.7	0.00	43.1	20.1	0.00	36.6	17.3	0.07	29.3	14.5	0.06
		67	45.1	26.5	0.07	39.1	23.7	0.07	33.2	20.9	0.06	26.7	18.1	0.05	20.0	15.2	0.08
		62	36.0	27.3	0.05	30.5	24.5	0.06	25.0	21.8	0.07	19.7	19.0	0.09	16.1	16.1	0.21
	1000	72	64.1	29.5	0.00	57.7	26.7	0.00	51.2	23.9	0.19	43.9	20.9	0.12	35.2	17.6	0.10
		67	53.6	31.8	0.11	46.8	28.7	0.10	40.1	25.6	0.10	32.3	22.3	0.09	24.1	18.8	0.11
		62	43.4	33.4	0.10	36.9	30.3	0.10	30.4	27.2	0.10	24.3	24.0	0.12	20.1	20.1	0.26
	1250	72	72.1	33.0	0.00	64.7	29.9	0.00	57.3	26.8	0.20	49.4	23.7	0.15	40.1	20.3	0.14
		67	59.6	35.8	0.14	52.4	32.7	0.14	45.3	29.5	0.13	36.8	25.9	0.13	27.5	22.0	0.15
		62	49.0	38.4	0.14	42.0	35.2	0.13	35.0	32.1	0.13	28.6	28.4	0.16	23.7	23.7	0.30
A036 N036 T036 W036	900	72	63.4	29.6	0.00	57.2	26.8	0.00	50.9	23.9	0.00	44.3	21.0	0.00	36.3	17.9	0.00
		67	52.1	31.0	0.00	46.0	28.1	0.00	39.8	25.1	0.00	32.8	22.1	0.00	24.9	18.8	0.01
		62	42.8	32.7	0.00	36.7	29.6	0.00	30.5	26.6	0.01	23.9	23.0	0.04	19.2	19.2	0.18
	1200	72	75.1	34.7	0.00	67.8	31.6	0.00	60.5	28.5	0.05	52.1	25.1	0.03	43.4	21.8	0.02
		67	61.6	37.2	0.02	54.5	34.0	0.02	47.5	30.8	0.02	39.3	27.3	0.02	30.2	23.4	0.04
		62	51.1	40.2	0.02	44.0	36.7	0.03	36.9	33.2	0.03	29.3	28.9	0.08	24.2	24.2	0.22
	1500	72	83.3	38.5	0.17	75.5	35.3	0.13	67.6	32.1	0.09	58.5	28.5	0.06	48.4	24.8	0.06
		67	69.4	42.5	0.06	61.3	38.9	0.06	53.1	35.4	0.05	44.4	31.7	0.05	34.5	27.5	0.07
		62	56.6	46.2	0.04	49.3	42.5	0.06	42.0	38.8	0.07	34.3	34.3	0.11	28.8	28.8	0.25
A042 N042 T042	1050	72	75.4	35.0	0.00	68.0	31.8	0.00	60.7	28.6	0.02	52.7	25.3	0.00	43.6	21.7	0.00
		67	62.1	37.3	0.00	55.0	34.0	0.00	47.8	30.7	0.00	39.3	26.9	0.01	30.2	23.1	0.03
		62	51.5	39.8	0.01	44.2	36.2	0.01	36.9	32.7	0.02	29.1	28.3	0.06	23.7	23.7	0.20
	1400	72	87.8	40.6	0.18	79.4	37.1	0.13	71.0	33.6	0.07	61.3	29.8	0.05	51.0	25.9	0.05
		67	72.9	44.4	0.05	64.4	40.7	0.04	55.9	36.9	0.04	46.7	33.0	0.04	36.1	28.5	0.06
		62	60.0	48.3	0.03	52.0	44.3	0.05	44.0	40.3	0.06	35.5	35.5	0.10	29.7	29.7	0.24
	1750	72	96.3	44.6	0.16	87.4	41.1	0.13	78.5	37.5	0.11	67.9	33.5	0.09	55.9	29.1	0.09
		67	80.8	50.1	0.08	71.5	46.1	0.08	62.2	42.2	0.08	51.9	37.9	0.08	40.9	33.4	0.10
		62	65.7	55.1	0.07	57.6	50.9	0.08	49.5	46.6	0.10	41.7	41.7	0.15	35.0	35.0	0.28
A048 N048 T048 W048	1200	72	79.8	36.9	0.00	72.6	33.7	0.00	65.4	30.6	0.12	57.0	27.1	0.08	47.5	23.4	0.07
		67	66.6	39.8	0.07	59.1	36.4	0.06	51.7	33.0	0.06	43.2	29.3	0.05	33.3	25.2	0.07
		62	55.2	42.8	0.06	47.6	39.1	0.06	40.0	35.4	0.06	32.2	31.3	0.08	26.7	26.7	0.20
	1600	72	91.0	42.1	0.22	83.0	38.7	0.18	75.0	35.4	0.13	65.4	31.7	0.11	54.5	27.6	0.10
		67	76.7	46.9	0.10	68.1	43.1	0.10	59.5	39.4	0.09	50.1	35.4	0.09	39.4	31.0	0.11
		62	62.7	51.0	0.08	54.9	47.2	0.09	47.1	43.4	0.10	39.3	39.0	0.13	33.1	33.1	0.25
	2000	72	99.2	46.1	0.19	90.7	42.7	0.17	82.2	39.4	0.15	72.0	35.5	0.14	60.0	31.2	0.13
		67	84.0	52.6	0.13	74.8	48.8	0.13	65.7	44.9	0.12	55.1	40.5	0.12	44.0	36.0	0.13
		62	69.0	58.5	0.11	60.8	54.3	0.12	52.6	50.2	0.14	45.4	45.4	0.18	38.5	38.5	0.30

CFM — Cubic Ft per Minute
EWB — Entering Wet Bulb (°F)
TC — Gross Cooling Capacity 1000 Btuh
SHC — Gross Sensible Capacity 1000 Btuh
BF — Bypass Factor
MBH — 1000 Btuh

GROSS COOLING CAPACITIES (MBH) Continued

UNIT SIZE	INDOOR COIL AIR		SATURATED TEMPERATURE LEAVING EVAPORATOR (°F)														
			30			35			40			45			50		
	CFM	EWB	TC	SHC	BF	TC	SHC	BF	TC	SHC	BF	TC	SHC	BF	TC	SHC	BF
A060 N060 T060	1600	72	101.0	46.7	0.00	90.8	42.2	0.00	80.4	37.6	0.12	69.1	33.0	0.08	56.0	28.0	0.07
		67	83.8	49.9	0.07	73.5	45.2	0.07	63.1	40.5	0.06	51.1	35.3	0.06	38.0	29.8	0.08
		62	68.7	53.0	0.07	58.2	48.0	0.07	47.7	43.0	0.07	38.2	37.6	0.11	31.6	31.6	0.24
	2000	72	113.0	52.2	0.00	102.0	47.4	0.00	90.4	42.6	0.14	77.5	37.5	0.11	63.5	32.3	0.10
		67	94.0	56.8	0.10	82.6	51.8	0.10	71.2	46.8	0.09	58.5	41.3	0.10	43.7	35.2	0.11
		62	77.0	61.2	0.09	66.0	56.0	0.10	55.1	50.7	0.10	45.0	44.7	0.15	37.3	37.3	0.28
	2400	72	123.0	56.6	0.26	111.0	51.6	0.21	98.4	46.7	0.16	84.2	41.2	0.13	69.4	35.8	0.13
		67	103.0	62.8	0.13	89.9	57.4	0.13	77.3	52.0	0.12	64.3	46.5	0.12	48.3	40.0	0.14
		62	83.0	68.4	0.11	72.2	63.0	0.12	61.4	57.5	0.13	51.1	51.1	0.18	42.5	42.5	0.32
X060	1600	72	106.0	49.0	0.00	94.4	44.0	0.00	83.1	39.0	0.07	71.6	34.3	0.05	58.4	29.1	0.06
		67	85.7	51.3	0.05	75.4	46.5	0.05	65.1	41.7	0.05	52.9	36.4	0.05	39.8	30.9	0.07
		62	70.8	54.8	0.04	59.6	49.2	0.05	48.4	43.7	0.06	38.0	37.2	0.13	31.1	31.1	0.26
	2000	72	116.0	53.7	0.18	105.0	49.2	0.14	94.7	44.7	0.10	81.6	39.5	0.08	67.3	34.0	0.08
		67	97.6	59.1	0.07	86.1	54.0	0.07	74.5	48.8	0.07	61.4	43.1	0.07	46.4	36.9	0.09
		62	80.0	64.0	0.05	68.4	58.1	0.07	56.8	52.1	0.09	45.0	44.7	0.16	37.4	37.4	0.29
	2400	72	128.0	59.4	0.17	116.0	54.4	0.15	104.0	49.4	0.12	89.9	43.9	0.10	74.1	38.0	0.10
		67	108.0	66.0	0.09	94.7	60.4	0.09	81.8	54.7	0.10	67.9	48.8	0.10	51.9	42.3	0.11
		62	86.4	71.3	0.08	75.0	65.4	0.10	63.6	59.5	0.12	52.1	52.1	0.17	43.3	43.3	0.31

CFM — Cubic Ft per Minute

EWB — Entering Wet Bulb (°F)

LWB — Leaving Wet Bulb (°F)

TC — Total Cooling Capacity 1000 Btuh

SHC — Total Sensible Capacity 1000 Btuh

BF — Bypass Factor

MBH — 1000 Btuh

3. Direct interpolation is permissible. Do not extrapolate.

4. SHC is based on 80°F db temperature of air entering coil.

Below 80°F db, subtract (Correction Factor x CFM) from SHC.

Above 80°F db, add (Correction Factor x CFM) to SHC.

5. All data points are based on 10°F superheat leaving coil.

6. Bypass Factor = 0 indicates no psychometric solution. Use bypass factor of next lower EWB for approximation.

NOTES:

1. Contact manufacturer for cooling capacities at conditions other than shown in table.

2. Formulas:

$$\text{Leaving db} = \text{entering db} - \frac{\text{sensible heat cap.}}{1.09 \times \text{CFM}}$$

Leaving wb = wb corresponding to enthalpy of air leaving coil (h_{LWB})

$$h_{LWB} = h_{EWB} - \frac{\text{total capacity (Btuh)}}{4.5 \times \text{CFM}}$$

where h_{EWB} = enthalpy of air entering coil.

BYPASS FACTOR	ENTERING AIR DRY BULB TEMPERATURE (°F)					
	79	78	77	76	75	Under 75
	81	82	83	84	84	Over 85
	Correction Factor					
0.10	0.98	1.96	2.94	3.92	4.91	Use formula shown below
0.20	0.87	1.74	2.62	3.49	4.36	
0.30	0.76	1.53	2.29	3.05	3.82	

Interpolation is permissible.

$$\text{Correction Factor} = 1.09 \times (1 - \text{BF}) \times (\text{db} - 80)$$

COIL STATIC PRESSURE DROP (In. WC)

UNIT SIZE	BULB	AIR QUANTITY (CFM)					
		400	500	600	700	800	—
A018	WET DRY	0.08	0.12	0.16	0.22	0.29	—
		0.07	0.11	0.15	0.20	0.27	—
A024	WET DRY	0.16	0.21	0.26	0.31	—	—
		0.14	0.19	0.24	0.29	—	—
W024	WET DRY	0.15	0.20	0.24	0.30	—	—
		0.13	0.18	0.23	0.29	—	—
A030	WET DRY	0.17	0.22	0.28	0.33	0.41	—
		0.16	0.21	0.27	0.32	0.40	—
W030	WET DRY	0.13	0.16	0.20	0.24	0.27	—
		0.10	0.14	0.17	0.20	0.24	—
A036 T036	WET DRY	0.18	0.22	0.26	0.30	0.35	—
		0.15	0.18	0.22	0.26	0.30	—
W036	WET DRY	0.15	0.18	0.21	0.25	0.28	—
		0.12	0.14	0.16	0.19	0.23	—
N036	WET DRY	0.24	0.29	0.36	0.44	—	—
		0.23	0.28	0.34	0.43	—	—
A042 T042	WET DRY	0.18	0.21	0.25	0.28	0.32	—
		0.14	0.16	0.19	0.23	0.24	—
N042	WET DRY	0.22	0.26	0.30	0.35	0.41	—
		0.18	0.22	0.26	0.30	0.34	—
A048 T048	WET DRY	0.21	0.24	0.28	0.31	—	—
		0.19	0.22	0.25	0.28	—	—
W048	WET DRY	0.16	0.17	0.19	0.21	0.23	—
		0.14	0.16	0.18	0.20	0.22	—
N048	WET DRY	0.25	0.30	0.34	0.40	—	—
		0.23	0.27	0.31	0.35	—	—
N060	WET DRY	0.27	0.30	0.33	—	—	—
		0.25	0.28	0.31	—	—	—
A060 T060	WET DRY	0.19	0.21	0.23	0.26	0.29	0.33
		0.17	0.19	0.21	0.23	0.25	0.28
X060	WET DRY	0.21	0.23	0.25	0.27	0.29	0.31
		0.16	0.18	0.20	0.22	0.25	0.27

INDOOR COIL PISTONS

UNIT	FACTORY-INSTALLED INDOOR PISTON SIZE
CK5A/CK5BA018	52
CK5A/CK5BA024, W024	59
CK5A/CK5BA030, W030	67
CK5A/CK5BA036, N036, T036, W036	70
CK5A/CK5BA042, N042, T042	78
CK5A/CK5BA048, N048, T048, W048	84
CK5A/CK5BA060, N060, T060, X060	90

SERVICE TRAINING

Packaged Service Training programs are an excellent way to increase your knowledge of the equipment discussed in this manual, including:

- Unit Familiarization
- Maintenance
- Installation Overview
- Operating Sequence

A large selection of product, theory, and skills programs is available, using popular video-based formats and materials. All include video and/or slides, plus companion book.

Classroom Service Training plus "hands-on" the products in our labs can mean increased confidence that really pays dividends in faster troubleshooting, fewer callbacks. Course descriptions and schedules are in our catalog.

CALL FOR FREE CATALOG 1-800-962-9212

Packaged Service Training

Classroom Service Training

A94328

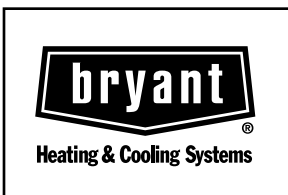

SPECIFICATIONS SUBJECT TO CHANGE WITHOUT NOTICE

UNIT MUST BE INSTALLED IN ACCORDANCE
WITH INSTALLATION INSTRUCTIONS

Cancels: PDS CJ5A.18.3