



Heating & Cooling Systems

**MODEL 340MAV, 350MAV, 352MAV,  
355MAV CONDENSING GAS  
FURNACE**

**USER:** Please read all instructions in the manual and retain all manuals for future reference.

**NOTE TO INSTALLER:**  
This manual must be left with the equipment user.

**⚠ WARNING:**  
**FIRE OR EXPLOSION HAZARD**  
Failure to follow safety warnings exactly could result in serious injury, death, or property damage.

- Do not store or use gasoline or other flammable vapors and liquids in the vicinity of this or any other appliance.
- **WHAT TO DO IF YOU SMELL GAS**
  - Do not try to light any appliance.
  - Do not touch any electrical switch; do not use any phone in your building.
  - Leave the building immediately.
  - Immediately call your gas supplier from a neighbor's phone. Follow the gas supplier's instructions.
  - If you cannot reach your gas supplier, call the fire department.
- Installation and service must be performed by a qualified installer, service agency or the gas supplier.

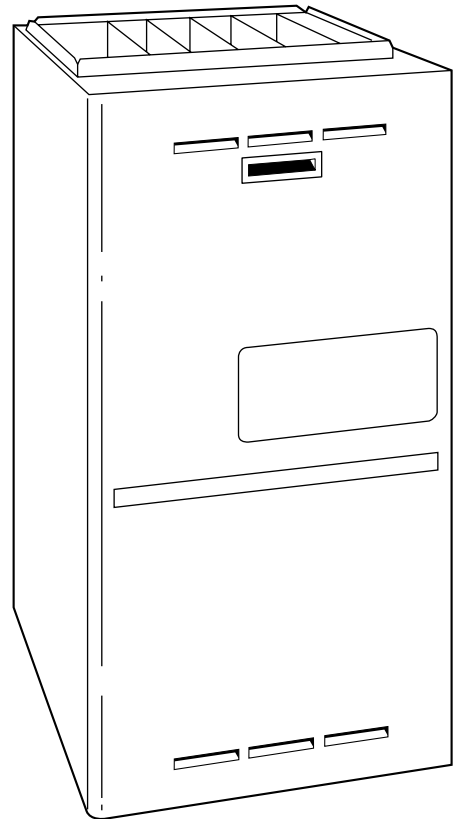

Do not use this furnace if any part has been under water. A flood-damaged furnace is extremely dangerous. Attempts to use the furnace can result in fire or explosion. A qualified service agency should be contacted to inspect the furnace and to replace all gas controls, control system parts, electrical parts that have been wet or the furnace if deemed necessary.

**⚠ WARNING:**  
Carbon Monoxide is invisible, odorless, and toxic! Bryant Heating and Cooling Systems recommends a carbon monoxide alarm in your home, even if you do not own a gas appliance. Locate the carbon monoxide alarm in the living area of your home and away from gas appliances and doorways to attached garages. Follow the alarm manufacturer's instruction included with the alarm.

# TABLE OF CONTENTS

WELCOME TO A NEW GENERATION OF COMFORT ..... 2

GENERAL FURNACE SAFETY ..... 2

FURNACE COMPONENTS ..... 3

SAFETY CONSIDERATIONS ..... 4

BEFORE STARTING YOUR FURNACE ..... 4

STARTING AND SHUTTING DOWN YOUR FURNACE ..... 4

    Steps for Starting Your Furnace ..... 4,5

Shutting Down Your Furnace ..... 6

PERFORMING ROUTINE MAINTENANCE ..... 6

    Filtering Out Trouble ..... 6

COMBUSTION AREA AND VENT SYSTEM ..... 8

    Heading South For the Winter ..... 10

A CHECK-UP CHECKLIST ..... 9,10

BEFORE YOU REQUEST A SERVICE CALL ..... 10

INSTALLATION DATA ..... 12

## WELCOME TO A NEW GENERATION OF COMFORT

Congratulations! In light of rising energy costs, the Plus 90™, 340MAV, Plus90t™ and Plus 90i™ Multipoise, Gas-Fired, Condensing Furnaces are among the soundest investments today's homeowner can make.

Your new furnace is truly a triumph of technology in home heating. A revolutionary design employs 2 heat exchangers to "squeeze" out the maximum amount of heat from the fuel consumed. In fact, your new furnace is so efficient, over 90%\* of the heat generated during combustion is captured and delivered inside your home. That is more than a 33%\* increase in heating efficiency over conventional furnaces.

These are among the most energy-efficient furnaces you can buy today. They also are among the safest and most dependable. We are proud of the technological advances incorporated into the design of these furnaces. With only minimal care, your new furnace will deliver many years of money-saving home comfort and enjoyment. Spend just a few minutes with this manual to learn the operation of your new furnace and the small amount of maintenance it takes to help keep it operating at peak efficiency year after year.

\* The output capacity and any representations of efficiency for this furnace are based on standard U.S. Department of Energy test procedures.



As an ENERGY STAR® Partner, Bryant Heating & Cooling Systems has determined that this product meets the ENERGY STAR® guidelines for energy efficiency.

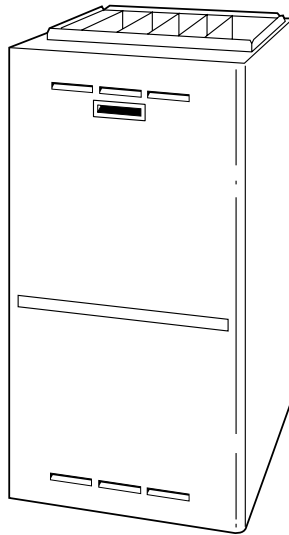

**MODELS 340MAV (SHOWN) AND 350MAV FIXED-CAPACITY FURNACES**

1

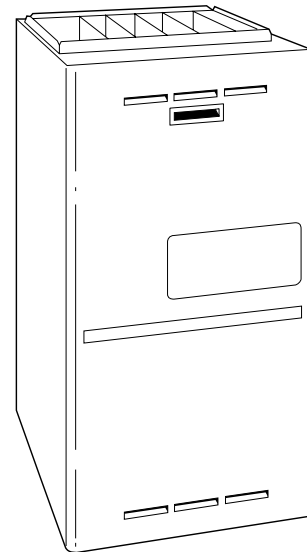

**MODEL 355MAV VARIABLE-CAPACITY AND MODEL 352MAV TWO-STAGE FURNACES**

2

## GENERAL FURNACE SAFETY

1. Combustible Materials, Gasoline Warning ..... 1,4

2. Furnace Must be Kept Free and Clear of Insulating Material Warning ..... 4

3. Furnace Needs Air for Combustion and Ventilation Warning ... 4

4. Starting (Lighting) and Shutting Down the Furnace Warning .. 7

5. Proper Furnace Shutdown Procedures ..... 5

6. Flood Damage Warning ..... 1

7. Fire or Explosion Hazard Warning ..... 1

8. Carbon Monoxide Warning ..... 1

9. Service and Maintenance Electrical Hazard Warning ..... 6

10. Improper Vent Warning ..... 7

11. Sharp Edges Caution ..... 6

12. No Filter Caution ..... 6

13. Filter Rod Modification Caution ..... 7

14. Dirt, Rust, or Accumulation Caution ..... 7

## FURNACE COMPONENTS

- 1 Combustion-air intake connection to ensure contaminant-free air (right or left side).
- 2 Burner sight glass for viewing burner flame.
- 3 Burner assembly (inside). Operates with energy-saving inshot burners and hot surface igniter for safe, dependable heating.
- 4 Redundant gas valve. Safe and efficient. Features 1 gas control with 2 internal shutoff valves. Valve appearance varies with furnace model.
- 5 Vent outlet. Uses PVC pipe to carry flue gas from the furnace's combustion system (right or left side).
- 6 Inducer motor. Pulls hot flue gases through the heat exchangers, maintaining negative pressure for added safety.
- 7 Blower access panel safety interlock switch.
- 8 Air filter and retainer.
- 9 Condensate drain connection. Collects moisture condensed from burned gases for disposal into home drain system. (Location in furnace varies.)
- 10 Heavy-duty blower. Circulates air across the heat exchangers to transfer heat into the home.
- 11 Secondary condensing heat exchanger (inside). Wrings out more heat through condensation. Constructed with polypropylene-laminated steel to ensure durability.
- 12 Primary serpentine heat exchanger (inside). Stretches fuel dollars with the S-shaped heat-flow design. Solid construction of corrosion-resistant aluminized steel means reliability.
- 13 Furnace control board.
- 14 3-amp fuse provides electrical and component protection.
- 15 Light emitting diode (LED) on furnace control board. Code light is for diagnosing furnace operation and service requirements.
- 16 Pressure switch(es) ensure adequate flow of flue gas through furnace and out vent system.
- 17 Rollout switch (manual reset) to prevent overtemperature.
- 18 Junction box for 115-v electrical power supply. (May be located on right or left side)
- 19 Transformer (24v) behind furnace control board provides low-voltage power to furnace control board and thermostat.

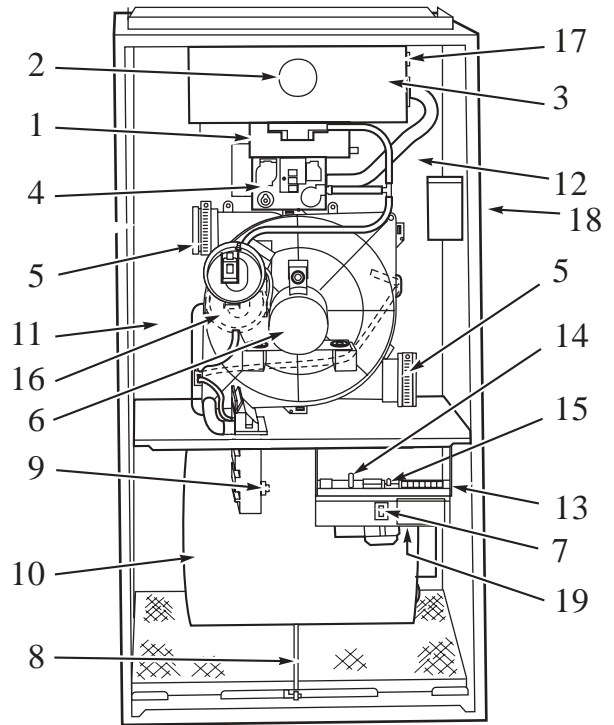

**MODELS 340MAV, 350MAV,  
AND 352MAV FURNACES  
(UPFLOW POSITION)**

3

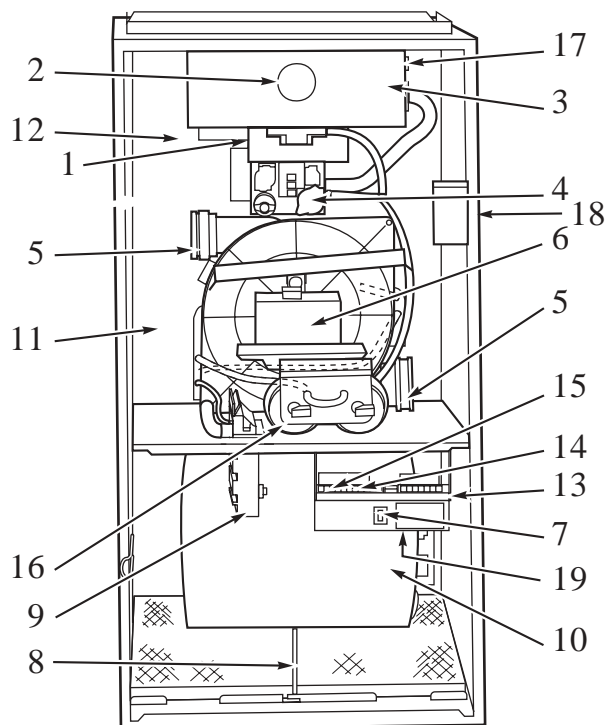

**MODEL 355MAV  
FURNACE (UPFLOW POSITION)**

4

## SAFETY CONSIDERATIONS

Recognize safety information. This is the safety-alert symbol . When you see this symbol on the furnace and in instructions or manuals, be alert to the potential for personal injury.

Understand the signal words DANGER, WARNING, CAUTION and NOTE. DANGER, WARNING and CAUTION are used with the safety-alert symbol. DANGER identifies the most serious hazards which **will** result in severe personal injury or death. WARNING signifies hazards which **could** result in personal injury or death. CAUTION is used to identify unsafe practices which **would** result in minor personal injury or product and property damage. NOTE is used to highlight suggestions which **will** result in enhanced installation, reliability, or operation.

To minimize the possibility of serious personal injury, fire, damage to your furnace, or improper operation, **carefully follow these safety rules:**

Your gas furnace uses air from outside the home for combustion and vents flue gas to the outdoors. It is not to be installed using in-house air. The vent and air-intake pipes must terminate outside the structure and must not be obstructed in any way. Do not block or obstruct air openings on furnace or spaces around the furnace.

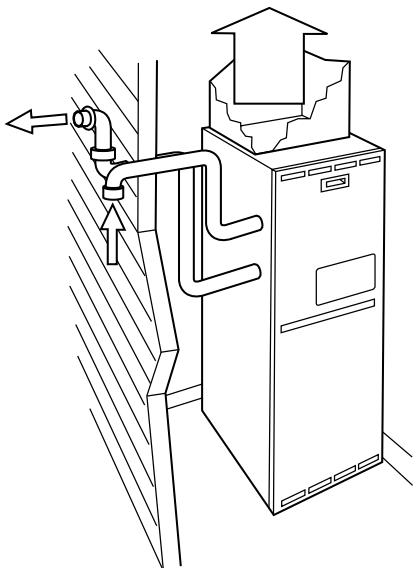

- 5**
- Keep the area around your furnace clear and free of combustible materials, gasoline, and other flammable liquids and vapors.

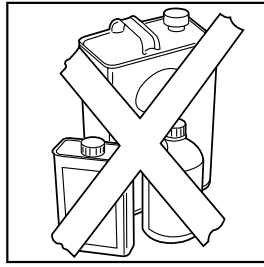

- 6**
- Do not cover the furnace, store trash or debris near it, or in any way block the flow of fresh air to the unit.
  - A furnace installed in an attic or other insulated space must be kept free and clear of insulating material. Examine the furnace area when the furnace is installed or when insulation is added. Some insulation materials may be combustible.

This furnace contains SAFETY DEVICES which must be MANUALLY RESET. If the furnace is left unattended for an extended period of time, have it checked periodically for proper operation. This precaution will prevent problems associated with no heat, such as frozen water pipes, etc. See "Before You Request a Service Call" section in this manual.

### WARNING

**Fire Hazard! Failure to keep insulation clear of furnace could result in fire, personal injury/death or property damage.**

### WARNING

**Do not keep combustible materials, gasoline, and other flammable liquids or vapors around your furnace. Failure to follow this warning could result in fire, personal injury/death or property damage.**

### WARNING

**For proper and safe operation the furnace needs air for combustion and ventilation. Do not block or obstruct the openings on the furnace, air openings to the area in which the furnace is installed, and the space around the furnace. Failure to follow this warning could result in fire, personal injury/death or property damage.**

## BEFORE STARTING YOUR FURNACE

Examine the furnace installation to determine that:

1. All flue gas carrying areas external to the furnace (i.e. chimney, vent connector) are clear and free of obstructions.
2. The vent connector is in place, slopes upward and is physically sound without holes or excessive corrosion.
3. The return-air duct connection(s) is physically sound, is sealed to the furnace casing, and terminates outside the space containing the furnace.
4. The physical support of the furnace is sound without sagging cracks, gaps, etc. around the base.
5. There are no obvious signs of deterioration of the furnace.
6. The pilot and burner flames are in good adjustment (by comparison with pictorial sketches or drawings of the main burner flame and, if applicable, the pilot burner flame).

## STARTING AND SHUTTING DOWN YOUR FURNACE

Instead of a continuously burning pilot flame which wastes valuable energy, your furnace uses an automatic, hot surface ignition system to light the burners each time the thermostat starts your furnace. **Follow these important safeguards:**

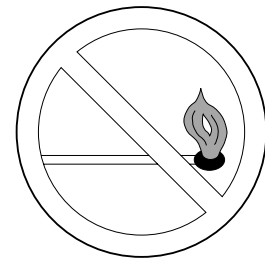

- 7**
- Never attempt to manually light the burners with a match or other source of flame.
  - Read and follow the operating instructions on inside of main furnace door, especially the item that reads as follows:

Wait 5 minutes to clear out any gas. Then smell for gas, including near

the floor. If you smell gas, **STOP!** Follow “B” in the safety information above on this furnace label. If you don’t smell gas, go to the next step.

- If a suspected malfunction occurs with your gas control system, such as the burners not lighting when they should, refer to the shutdown procedures on inside of main furnace door, or in the “Shutting Down Your Furnace” section and call your dealer as soon as possible.

**⚠ WARNING**

**If overheating occurs or the gas valve fails to shut off the gas supply, turn off the external manual gas valve to the furnace BEFORE turning off the electrical supply. (See Fig. 9.) Failure to follow this warning could result in a fire or explosion, and personal injury/death or property damage.**

**CHECK AIR FILTER:** Before attempting to start your furnace, be sure the furnace air filter is clean and in place. See “Performing Routine Maintenance” section in this manual. Then proceed as follows:

**STEPS FOR STARTING YOUR FURNACE**

1. Set your room thermostat to the lowest temperature setting. (See Fig. 8.)

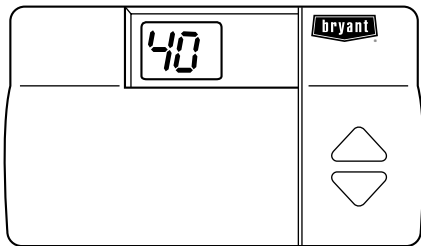

8

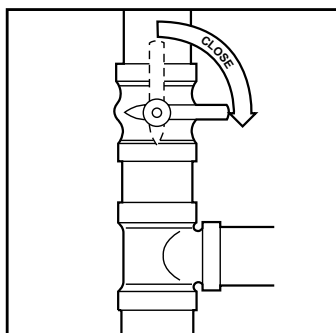

9

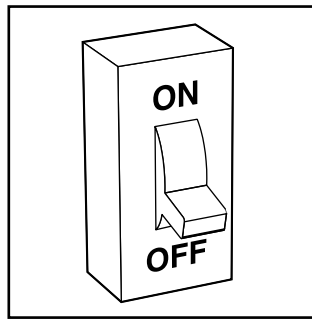

10

2. Close the external manual gas valve. (See Fig. 9.)
3. Turn OFF electrical supply to the furnace. (See Fig. 10.)
4. Remove main furnace door. (See Fig. 11.)
5. The gas valve will have a control switch to turn OFF or ON. Turn control switch on the gas control to the OFF position and wait 5 minutes. (See Fig. 12 or 13.) Then smell for gas, including near the floor. If you smell gas, **STOP!** Follow “B” on furnace label. If you don’t smell gas, go to next step.
6. After waiting 5 minutes, turn control switch on the gas valve to the ON position. (See Fig. 14 or 15.)
7. Replace main furnace door. (See Fig. 16.)

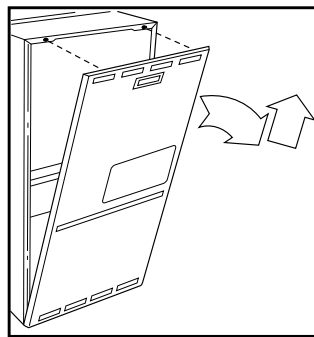

11

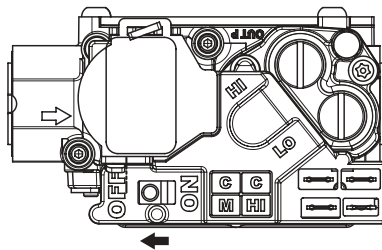

For 352MAV and 355MAV

12

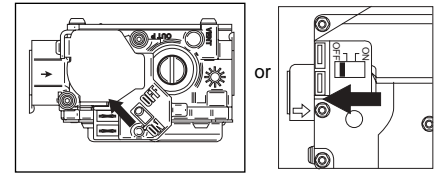

For 340MAV and 350MAV

13

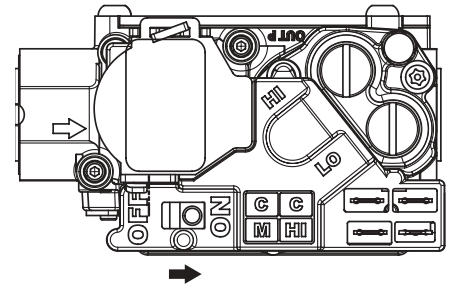

For 352MAV and 355MAV

14

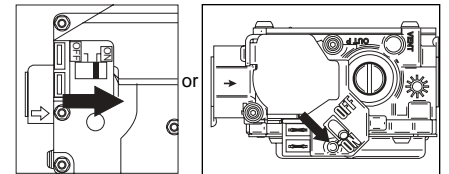

For 340MAV and 350MAV

15

8. Turn ON electrical supply to the furnace and wait 1 minute. (See Fig. 17.)
9. Open the external manual gas valve. (See Fig. 18.)
10. Set room thermostat to a temperature slightly above room temperature. This will automatically signal the furnace to start.
11. When the furnace receives the start signal, the inducer is started. When the pressure switch senses that there is sufficient combustion air, the hot surface igniter is energized. After the hot surface igniter is heated for 17 seconds, the gas valve permits gas to flow to the main burners. After ignition and a time delay of about 60 sec, the furnace blower will start. Variable-capacity furnaces start at low speed until the control makes the

necessary adjustments to operate the blower at either the low- or high-heat speed.

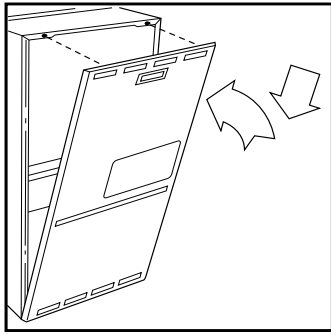

16

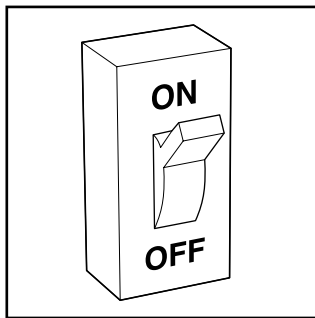

17

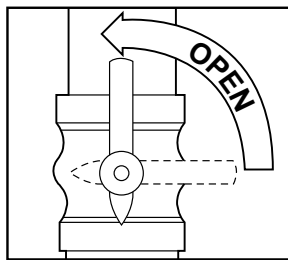

18

**NOTE:** If the burners fail to ignite after 4 attempts, the furnace control system will lock out. If lockout occurs, main burners fail to light, or blower does not come on, shut down the furnace and call your dealer for service.

12. Set your thermostat to the temperature that satisfies your comfort requirements.

**SUGGESTION:** Setting the thermostat back a few degrees and compensating for the difference with warmer clothing can make a big difference in your fuel consumption. The few degrees at the top of your thermostat “comfort level” are the most costly degrees to obtain.

When room temperature drops below the temperature selected on the thermostat, the furnace will be switched on automatically. When room temperature reaches the temperature selected on the thermostat, the furnace will be switched off automatically.

Some thermostats have a FAN mode with 2 selections, AUTO and ON. When thermostat is set to AUTO, the furnace blower cycles on and off. In ON mode, the furnace blower runs continuously. Continuous fan keeps the temperature level in your home more evenly balanced. It also permits the indoor air to be continuously filtered. Fan On *Plus*<sup>TM</sup>—On all but the 340MAV, the blower speed can be increased or decreased if desired due to change of seasons, large gatherings in your home, etc. Simply change your FAN from ON to OFF (or AUTO depending on your thermostat), and then return to ON. The blower will switch to the next highest speed. There are at least 3 speeds to choose from. If the blower is running on its highest speed, a request to change will direct the blower to return to its lowest speed.

### SHUTTING DOWN YOUR FURNACE

Should you need to shut down your furnace for service or maintenance, you will need to turn the furnace off.

The following procedures must be followed:

1. Set your room thermostat to the lowest temperature setting. (See Fig. 19.)

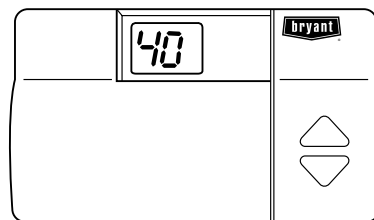

19

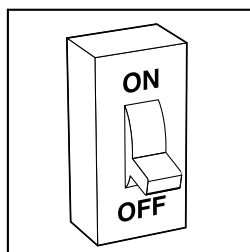

2. Close the external manual gas valve. (See Fig. 9.)
3. Turn off electrical supply to the furnace. (See Fig. 20.)
4. Remove main furnace door. (See Fig. 11.)
5. Turn switch on the gas valve to OFF position. (See Fig. 21 or 22.)

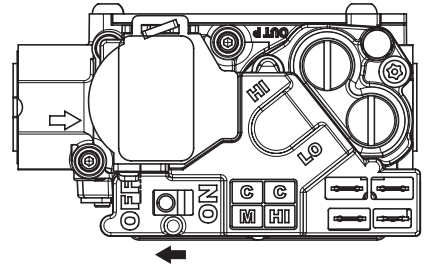

For 352MAV and 355MAV

21

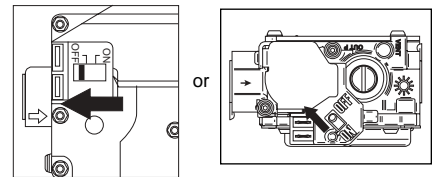

For 340MAV and 350MAV

22

6. Replace main furnace door. (See Fig. 16.)
7. If the furnace is being shut down because of a malfunction, call your dealer as soon as possible.

### ⚠ CAUTION

Furnace is not to be installed, operated, and then turned off and left turned off in an unoccupied structure during winter. (See “Heading South for the Winter?” procedures in maintenance section on page 9.) Freeze damage to furnace would occur.

### PERFORMING ROUTINE MAINTENANCE

**NOTE:** The qualified installer or agency must use only factory-authorized replacement parts, kits, and accessories when modifying this product.

Installing and servicing of heating equipment can be hazardous due to gas and electrical components.

Only trained and qualified personnel should install, repair, or service heating equipment. Untrained personnel can perform basic maintenance functions such as cleaning and replacing air filters.

All other operations must be performed by trained and qualified service agency personnel. Observe safety precautions in this manual, on tags, and on labels attached to the furnace and other safety precautions that may apply.

With proper maintenance and care, your furnace will operate economically and dependably. Instructions for basic maintenance are found on this and the following pages. However, before beginning maintenance, follow these safety precautions:

### ⚠ WARNING

Turn off electrical power supply to your furnace before removing the main furnace door to service or perform maintenance. Failure to follow this warning could result in personal injury/death or property damage.

### ⚠ CAUTION

Although special care has been taken to minimize sharp edges, be extremely careful when handling parts or reaching into the furnace. Failure to follow this caution would result in minor personal injury.

## FILTERING OUT TROUBLE

### ⚠ CAUTION

Never operate your furnace without the air filter in place. Doing so may damage the furnace blower motor. An accumulation of dust and lint on internal parts of your furnace can cause a loss of efficiency and would cause minor property or product damage.

A dirty air filter will cause a loss of airflow in your duct system. When excessive loss

of airflow occurs, the furnace may cycle on its safety controls. If this condition is left unattended, the furnace will eventually lock out. It is recommended that the furnace air filter be checked every 3 or 4 weeks and cleaned if necessary.

If installed with factory-specified disposable media filter, check or replace filter before each heating and cooling season. Replace media filter at least once a year.

The air filter is normally located in the blower compartment (See Fig. 3 or 4.) or in the factory-supplied filter cabinet attached to the side or bottom of the furnace casing. If air filter has been installed in another location, contact your dealer for instructions. To inspect, clean, and/or replace the air filter(s), follow these steps:

1. Turn off electrical supply to furnace. (See Fig. 20.)

2. Remove door/access panel

- AIR FILTER(S) LOCATED IN BLOWER COMPARTMENT

a. Remove main furnace door.

(See Fig. 23.)

b. Remove blower access panel.

(See Fig. 24.)

**NOTE:** It will be necessary to remove 2 screws

- AIR FILTER LOCATED IN FILTER CABINET

a. Remove filter cabinet door (See Fig. 25 and 26.)

**NOTE:** It will be necessary to remove 1 thumbscrew

3. Remove air filter from furnace.

- AIR FILTER LOCATED IN BLOWER COMPARTMENT BOTTOM:

a. Slide filter retainer sideways until it is free of latch. (See Fig. 27.)

b. Slide air filter out of furnace. (See Fig. 28.)

- AIR FILTER(S) LOCATED IN BLOWER COMPARTMENT SIDE:

a. Remove filter retainer from latch. (See Fig. 29.)

b. Gently remove air filter and carefully turn the dirty side up (if dirty) to avoid spilling dirt from the filter. (See Fig. 30.)

- AIR FILTER LOCATED IN FILTER CABINET:

a. Slide air filter out of furnace. Keep dirty side up (if dirty) to avoid spilling dirt. (See Fig. 31 and 32.)

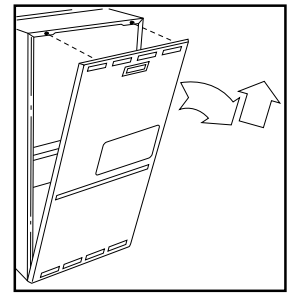

23

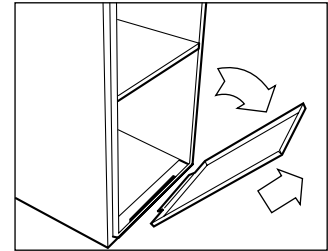

24

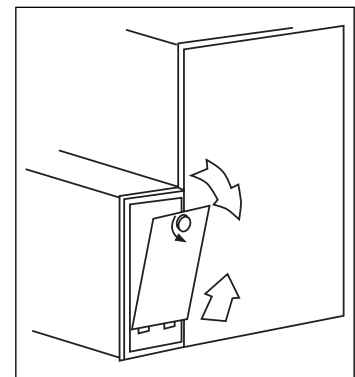

25

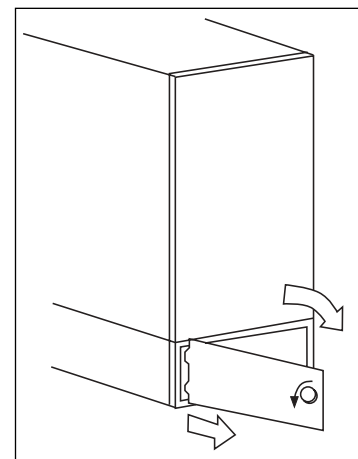

26

4. Inspect the filter. If torn, replace it.

**NOTE:** If washable filter that was shipped with the furnace has been replaced by:

a. Factory specified disposable media filter – Do not clean. If dirty, replace only with media filter having the same part number and size. Install with airflow

direction arrow pointing towards blower.

b. Electronic air cleaner (EAC) – Refer to EAC owner's Manual for maintenance information.

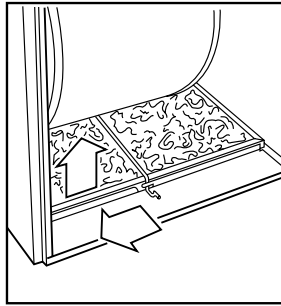

27

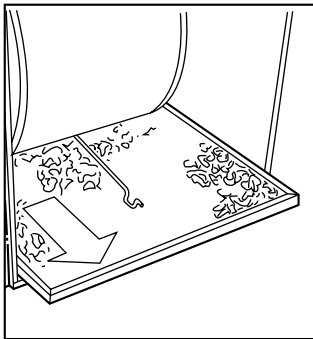

28

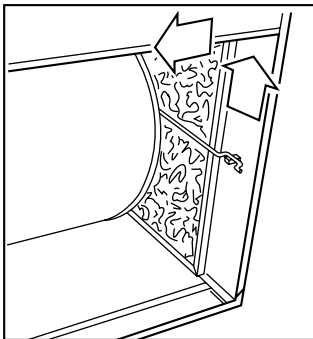

29

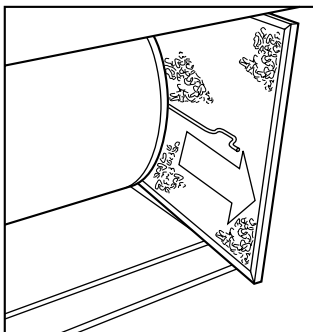

30

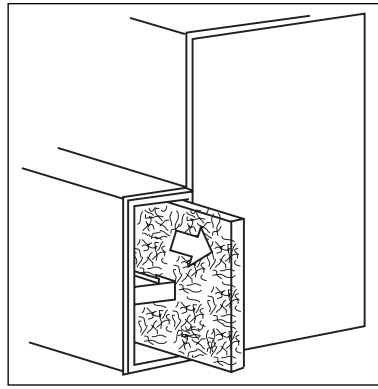

31

5. If washable filter, wash filter (if dirty) in sink, bathtub, or outside with a garden hose. Always use cold tap water. A mild liquid detergent may be used if necessary. Spray water through filter in the opposite direction of airflow. Allow filter to dry.

6. Reinstall clean air filter.

7. Reinstall filter retainer (for blower compartment locations only).

8. Replace blower access panel and main furnace door (See Fig. 33 and 34) or filter cabinet door (Fig. 35 and 36.)

9. Turn on electrical supply to furnace.

If your furnace air filter needs to be replaced, be sure to use a factory authorized filter of the same size that was originally supplied. Use the filter tables and compare your furnace size with the proper filter size.

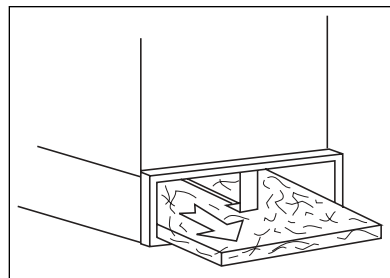

32

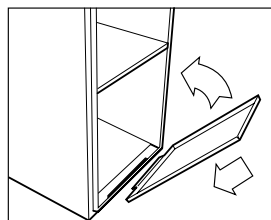

33

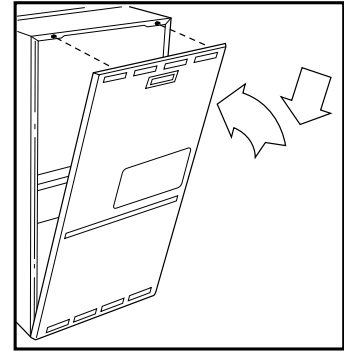

34

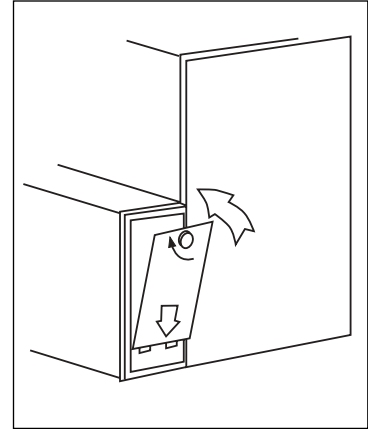

35

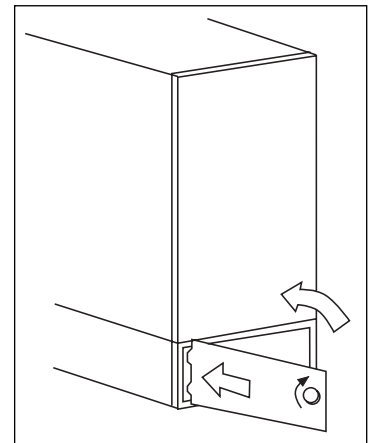

36



## FURNACE AIR FILTER TABLE

AIR FILTER LOCATED IN BLOWER COMPARTMENT			
FURNACE CASING WIDTH (IN.)	FILTER SIZE (IN.)		FILTER TYPE
	*Side Return†	Bottom Return	
17-1/2	(1) 16 x 25 x 1*	(1) 16 x 25 x 1*	Cleanable
21	(1) 16 x 25 x 1	(1) 20 x 25 x 1*	Cleanable
24-1/2	(1 or 2) 16 x 25 x 1	(1) 24 x 25 x 1*	Cleanable

AIR FILTER LOCATED IN FILTER CABINET:		
FILTER CABINET HEIGHT (IN.)	FILTER SIZE (IN.)	FILTER TYPE
16	(1) 16 x 25 x 1* or (1) 16 x 25 x 4-5/16	Cleanable or Disposable
20	(1) 20 x 25 x 1* or (1) 20 x 25 x 4-5/16	Cleanable or Disposable
24	(1) 24 x 25 x 1* or (1) 24 x 25 x 4-5/16	Cleanable or Disposable

\* Factory-provided with the furnace. Filters may be field modified by cutting filter material and support rods (3) in filters. Alternate sizes and additional filters may be ordered from your dealer.

† Upflow only.

### ⚠ CAUTION

Use care when cutting support rods in filters to protect against flying pieces and sharp rod ends. Wear safety glasses, gloves, and appropriate protective clothing. Failure to follow this caution could result in personal injury.

## COMBUSTION AREA AND VENT SYSTEM

Visually inspect the combustion area and vent system before each heating season. Make sure that all PVC pipes leading into the combustion area and vent are free from any cracks and sags.

### ⚠ DANGER

If holes are found in the pipes or if any portion has become disconnected, toxic fumes can escape into your home. **DO NOT OPERATE YOUR FURNACE.** Call your dealer for service. Failure to follow this warning could result in personal injury or death.

Also check the combustion-air intake and vent pipes on the outside of your home for blockage.

When dirt, soot, scale, or rust is allowed to build up, your furnace can suffer a loss of efficiency and perform improperly. Accumulations on the main burners can result in firing out of normal sequence. This delayed ignition creates an alarmingly loud sound.

### ⚠ CAUTION

If your furnace makes an especially loud noise when the main burners light, shut down your furnace and call your dealer. Failure to follow this caution would result in minor property damage.

To inspect the combustion area and vent system, you will need a flashlight. Refer to Fig. 3 or 4, and proceed as follows:

1. Turn off gas and electrical supplies to the furnace and remove the main furnace door. (See Fig. 9, 10, and 11.)
2. Remove burner enclosure front. (See Fig. 37 or 38.)

Inspect the gas burners, igniter area, and remainder of furnace for dirt, rust, soot, or scale.

### ⚠ CAUTION

If dirt, rust, soot, or scale accumulations are found, call your dealer. Do not operate your furnace. Failure to follow this caution would result in minor property or product damage.

3. Inspect the combustion-air and vent PVC pipes for sags, holes, cracks, or disconnections. Horizontal portions of pipes must slope downward toward furnace.

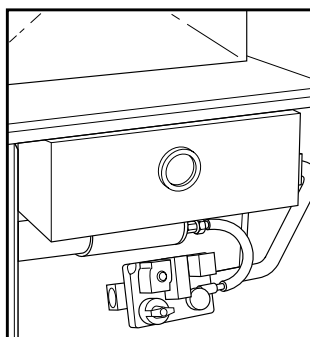

UPFLOW

37

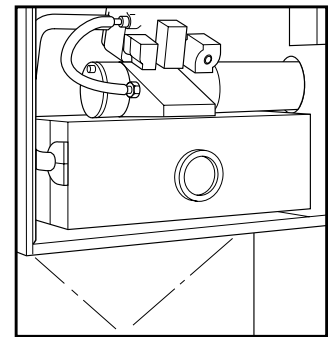

DOWNFLOW

38

4. Reinstall burner enclosure front.
5. If your furnace is free of the above conditions, replace main furnace door and turn on electrical and gas supplies to your furnace. (See Fig. 16, 17, and 18.)
6. Start the furnace and observe its operation. Watch the burner flames to see if they are clear blue, almost transparent. (See Fig. 39.) If you observe a suspected malfunction, or the burner flames are not clear blue, call your dealer.

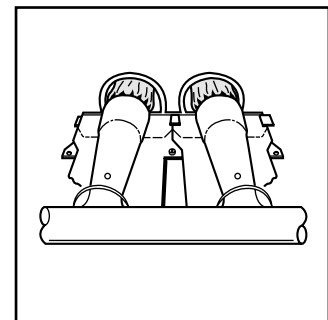

39

## HEADING SOUTH FOR THE WINTER?

DON'T FORGET YOUR FURNACE!

### ⚠ CAUTION

If the furnace is installed in an unconditioned space where the ambient temperatures may be 32°F or lower, freeze protection measures must be taken to prevent minor property or product damage.

Since the furnace uses a condensing heat exchanger, some water will accumulate in the unit as a result of the heat

transfer process. Therefore, once it has been operated, it cannot be turned off and left off for an extended period of time when temperatures will reach 32°F or lower unless winterized. Follow these procedures to winterize your furnace:

1. Obtain propylene glycol (RV/swimming pool antifreeze or equivalent).

### ⚠ CAUTION

**Do not use ethylene glycol (Prestone II antifreeze coolant or equivalent). Failure of plastic components will occur.**

2. Turn off electrical supply to the furnace. (See Fig. 20.)
3. Remove main furnace door. (See Fig. 23.)
4. Remove upper inducer housing drain connection cap. (See Fig. 40.)
5. Connect field-supplied 1/2-in. ID tube to upper inducer housing drain connection.
6. Insert field-supplied funnel into tube.

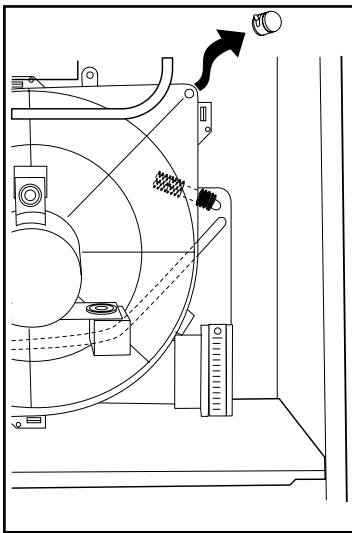

40

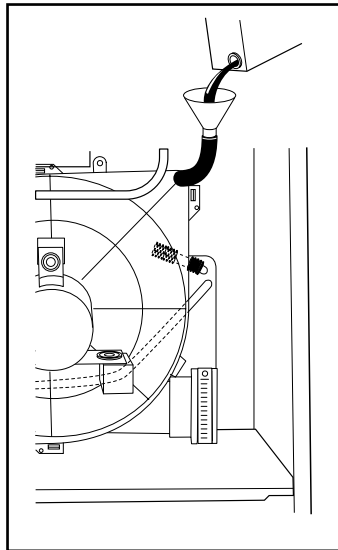

41

7. Pour 1 quart of antifreeze into funnel/tube. Antifreeze should run through inducer housing, overflow condensate trap, and flow into open field drain. (See Fig. 41.)
8. Remove funnel and tube from inducer housing and replace drain connection cap and clamp.
9. Replace main furnace door. (See Fig. 34.)
10. Propylene glycol need not be removed before restarting furnace.

## A CHECK-UP CHECKLIST

Your furnace represents an important investment in your family's comfort and your home's value. To keep it performing properly and to prevent future problems, have a trained service specialist give your furnace a professional check-up annually. The following checklist can be used as a guideline to proper service:

- Inspect all flue gas passages, burners, heat exchangers, coupling box(es), and inducer assembly.
- Inspect all combustion-air and vent piping inside structure and pipe terminations outside the structure.
- Check gas pipes leading to and inside of your furnace for leaks.

- Inspect and clean the blower motor and wheel.

**NOTE:** The inducer and blower motors are pre-lubricated and require no additional lubrication. These motors can be identified by the absence of oil ports on each end of the motor.

- Inspect and change or clean air filter(s) if necessary.
- Inspect all supply- and return-air ducts for obstructions, air leaks, and insulation. Remedy any problem when necessary.
- Inspect the return-air duct connection(s) at the furnace to ensure it is physically sound, sealed to the furnace casing, and terminates outside the space containing the furnace.
- Inspect electrical wiring, connections, and components for loose connections.
- Perform an operational checkout to determine whether your furnace is working properly and if it requires adjustments.
- Inspect all condensate drain tubes and condensate trap assembly for leaks. The condensate removal system should be cleaned annually by a qualified service agency. Refer to the Service and Maintenance Instructions for further information.
- Examine the physical support of the furnace. The support should be sound with no cracks, sagging, gaps, etc. around the base.
- Check furnace for any obvious signs of deterioration.

## BEFORE YOU REQUEST A SERVICE CALL

If your furnace is not operating or not performing properly, you may save the expense of a service call by checking a few things yourself before calling for service.

### FOR INSUFFICIENT AIRFLOW:

- Check for dirty air filter(s).
- Check for blocked return-air or supply-air grilles throughout your home.

Ensure they are open and unobstructed. If problem still exists, call your dealer for service.

**IF FURNACE FAILS TO OPERATE:**

Follow this checklist step by step, advancing to the next step only if furnace fails to start.

- Check thermostat for proper temperature. Is thermostat set above room temperature?
- Is thermostat set to HEAT?
- Check fuses and circuit breakers. Is electrical supply on?
- Is manual shutoff valve in gas supply pipe in open position? (Follow start-up procedures if you open gas valve.)

**NOTE:** Turn off electrical supply before continuing with checklist.

- Is control switch on gas valve in ON position? (Follow start-up procedures if you must reset switch to ON position.)
- Check manual reset flame rollout switch located on the burner box in combustion area. (See Fig. 3 or 4.) If furnace has experienced high temperature conditions, this switch will shut off the furnace. Reset it by pushing the button on the switch. If it trips again, shut down the furnace and call for service. See “Shutting Down Your Furnace” section in this manual.
- Check for obstructions around the

vent termination outside the structure.

If your furnace still fails to operate, call your service representative.

For your convenience, record the furnace product and serial numbers on back page. Should you ever require service, you will have ready access to the information needed by your service representative.

This furnace has a light emitting diode (LED) status code display to aid the installer, service technician, or homeowner while installing or servicing the unit. The LED code can be seen by removing the access door and viewing LED through the view port in the blower access panel.

**INSTALLATION DATA**

Date Installed \_\_\_\_\_  
Dealer Name \_\_\_\_\_  
Address \_\_\_\_\_  
City \_\_\_\_\_  
State \_\_\_\_\_ Zip \_\_\_\_\_  
Telephone \_\_\_\_\_

**FURNACE**

Product No. \_\_\_\_\_  
Model No. \_\_\_\_\_  
Serial No. \_\_\_\_\_

**AIR CONDITIONER OR HEAT PUMP**

**OUTDOOR UNIT:**

Product No. \_\_\_\_\_  
Model No. \_\_\_\_\_  
Serial No. \_\_\_\_\_

**INDOOR COIL:**

Product No. \_\_\_\_\_  
Model No. \_\_\_\_\_  
Serial No. \_\_\_\_\_

