



Beckett
COMMERCIAL

CF500
CF800

OIL BURNER MANUAL

Operation: On/Off

Rate: CF500: 1.75 - 5.50 GPH,

CF800: 3.00 - 8.00 GPH

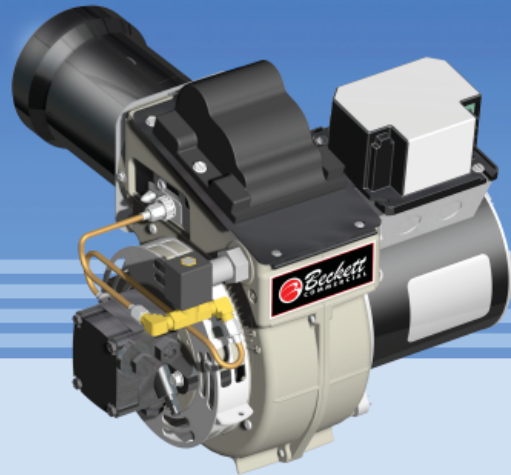

WARNING

Potential for Fire, Smoke and Asphyxiation Hazards



Incorrect installation, adjustment, or misuse of this burner could result in death, severe personal injury, or substantial property damage.

To the Homeowner or Equipment Owner:

- Please read and carefully follow all instructions provided in this manual regarding your responsibilities in caring for your heating equipment.
- Contact a professional, qualified service agency for installation, start-up or service work.
- Save this manual for future reference.

To the Professional, Qualified Installer or Service Agency:

- Please read and carefully follow all instructions provided in this manual before installing, starting, or servicing this burner or heating system.
- The Installation must be made in accordance with all state and local codes having jurisdiction.

Before you begin . . .

The following resources will give you additional information for your installation. We suggest that you consult these resources whenever possible. Pay particular attention to the appliance manufacturer's instructions.

Appliance manufacturer's instructions -Always follow the appliance manufacturer's instructions for burner installation, equipment and set-up.

1-800-OIL-BURN - Beckett's technical services hot-line.

www.beckettcorp.com - Beckett's website.

Table of Contents

General Information	3-4
To the Owner	3
Hazard Definitions	3
Agency approvals	3
Specifications	3
Owner's Responsibility	4
Professional Installer/Service Agency Responsibility	4
Pre-installation checklist	4-6
Combustion air supply	5
Clearances	5
Fuel supply	5
Nozzle pressure	5
Vent system	5
Electrical supply	5
Verify burner components	5
Verify firing rate	6
Verify air tube	6
Mount the burner	7-9
Mount flanges on air tubes	7
Mount air tube to burner	8
Install Nozzle	8
Check Electrode Settings	8
Install Nozzle Line Assembly	8
Set Dimension Z	8
Insert Burner	8
Fuel Unit By-pass Plug	9
Connect fuel lines	9
Oil Supply/Return Lines	9
Burner Fuel Flow	9
Wire the burner	10
Prepare the burner for start-up	10-11
Start-up checklist	11
Z Dimension	11
Initial head position	11
Initial air settings	11
Set appliance limit controls	11
Prepare the fuel unit for air venting	11
Start the burner	12
Starting the burner and venting air	12
Resetting from restricted lockout	12
Disable function	12
CAD Cell resistance check	12
Set combustion using instruments	13
Sequence of operation	13
Maintenance and Service	14
Annual Service	14
Monthly maintenance	14
Replacement Parts	15
Warranty	Back Cover

To the Owner:

Thank you for purchasing a Beckett burner for use with your heating appliance. Please pay attention to the Safety Warnings contained within this instruction manual. Keep this manual for your records and provide it to your qualified service agency for use in professionally setting up and maintaining your oil burner.

Your Beckett burner will provide years of efficient operation if it is professionally installed and maintained by a qualified service technician. If at any time the burner does not appear to be operating properly, **immediately contact your qualified service agency** for consultation.

We recommend annual inspection/service of your oil heating system by a qualified service agency.

Within the boundaries of the hazard warning, there will be information presented describing consequences if the warning is not heeded and instructions on how to avoid the hazard.

Agency approvals



- UL listed to comply with ANSI/UL296 and certified to CSA B140.0.
- Accepted by N.Y.C. M.E.A.
- Other approvals may be available and must be specified at time of order.

Hazard definitions

DANGER Indicates an imminently hazardous situation, which, if not avoided, will result in death, serious injury, or property damage.

WARNING Indicates a potentially hazardous situation, which, if not avoided, could result in death, severe personal injury, and/or substantial property damage.

CAUTION Indicates a potentially hazardous situation, which, if not avoided, may result in personal injury or property damage.

NOTICE

Intended to bring special attention to information, but not related to personal injury or property damage.

Specifications

Fuels	U.S. #1 or #2 Fuel Oil only (ASTM D396) Canada #1 Stove Oil or #2 Furnace Oil only
Firing range	CF500: 1.75 to 5.50 GPH CF800: 3.00 to 8.00 GPH
Motor	1/3 HP 3450 RPM
	120/60 hz standard
	4.8 amps @ 120 VAC
	Optional voltages: (60 hz or 50 hz)
Igniter.	120V/14,000V
Housing	Cast aluminum
Fuel unit	100 - 200 PSIG
Oil nozzle	45° - 70° solid
Shipping wt.	55 lbs.

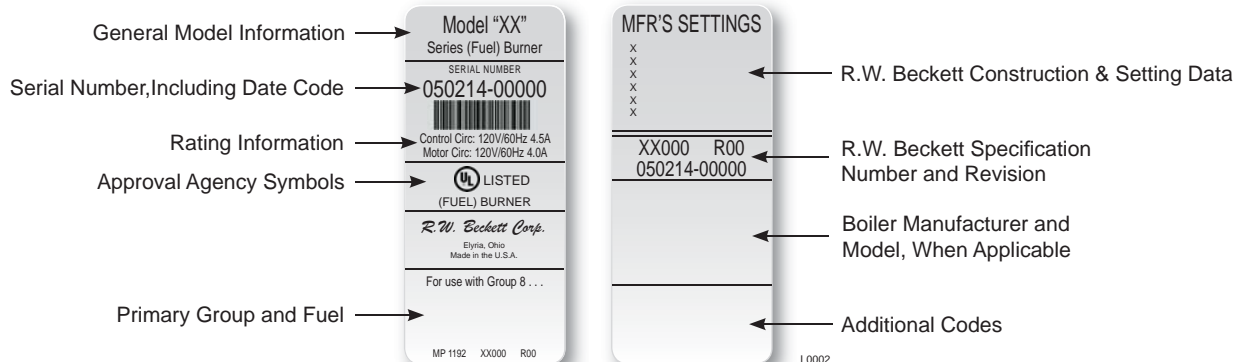

Owner's Responsibility:

NOTICE



WARNING

Follow These Instructions Exactly



Failure to follow these instructions, misuse, or incorrect adjustment of the burner could lead to equipment malfunction and result in asphyxiation, explosion or fire.

Contact a professional, qualified service agency for the installation, adjustment and service of your oil burning system. Thereafter, have your equipment adjusted and inspected at least annually to ensure reliable operation. This work requires technical training, trade experience, licensing or certification in some states and the proper use of special combustion test instruments.

Please carefully read and comply with the following instructions:

- Never store or use gasoline or other flammable liquids or vapors near this burner or appliance.
- Never attempt to burn garbage or refuse in this appliance.
- Never attempt to light the burner by throwing burning material into the appliance.
- Never attempt to burn any fuel not specified and approved for use in this burner.
- Never restrict the air inlet openings to the burner or the combustion air ventilation openings in the room.

Professional Installer/Service Agency Responsibility:



WARNING

Follow These Instructions Exactly



Failure to follow these instructions could lead to equipment malfunction and result in asphyxiation, explosion or fire.

- Please read all instructions before proceeding. Follow all instructions completely.
- This equipment must be installed, adjusted and started by a qualified service agency that is experienced with all applicable codes and ordinances and responsible for the installation and commission of the equipment.
- The installation must comply with all local codes and ordinances having jurisdiction and the latest editions of the NFPA 31 and CSA-B139 & B140 in Canada.

NOTICE

50 Hz motors — The burner ratings, air settings and nozzle ratings are based on standard 60 hz motors (at 3450 rpm). Derate all ratings 20% when using 50 hz motors. Consult factory for specific application data.

High altitude installations — Accepted industry practice requires no derate of burner capacity up to 2,000 feet above sea level. For altitudes higher than 2,000 feet, derate burner capacity 2% for each 1000 feet above sea level.

Pre-installation checklist



CAUTION

Protect Against Stray Light Lockout

Failure to follow these instructions could cause loss of burner operation resulting in no heat, an unplanned process interruption, work stoppage and the potential for frozen plumbing or other cold weather property damage.

- The control must detect a dark, no-flame condition in order to start the burner or it will hold in the stray light lockout mode.
- Shield the burner from direct exposure to intense light.



WARNING

Protect Against Dust and Moisture

Wet, dusty environments could lead to blocked air passages, corrosion damage to components, impaired combustion performance and result in asphyxiation, explosion or fire.

- This burner is designed for clean, dry installations.
- Electrical controls are not protected against rain or sprayed water.
- Keep the installation clear of dust, dirt, corrosive vapors, and moisture.
- Protective covers and more frequent maintenance may be required.



WARNING

Adequate Combustion and Ventilation Air Supply Required

Failure to provide adequate air supply could seriously affect the burner performance and result in damage to the equipment, asphyxiation, explosion or fire hazards.

- The burner cannot properly burn the fuel if it is not supplied with a reliable combustion air source.
- Follow the guidelines in the latest editions of the NFPA 31 and CSA-B139 regarding providing adequate air for combustion and ventilation.

☐ Combustion air supply

- The burner requires combustion air and ventilation air for reliable operation. Assure that the building and/or combustion air openings comply with National Fire Protection Standard for Oil-Burning Equipment, NFPA 31. For appliance/burner units in confined spaces, the room must have an air opening near the top of the room plus one near the floor, each with a free area at least one square inch per 1,000 Btu/hr input of all fuel burning equipment in the room. For other conditions, refer to NFPA 31 (CSA B1139-M91 in Canada).
- If there is a risk of the space being under negative pressure or of exhaust fans or other devices depleting available air for combustion and ventilation, the appliance/burner should be installed in an isolated room provided with outside combustion air.

☐ Clearances

- With the burner installed in the appliance, there must be adequate space in front of and on the sides of the burner to allow access and operation. Verify that the clearance dimensions comply with all local codes and with the appliance manufacturer's recommendations.

☐ Fuel supply

- The fuel supply piping and tank must provide #1 or #2 fuel oil at pressure or vacuum conditions suitable for the fuel unit (oil pump) on the burner. Refer to fuel unit literature in the literature envelope in the burner carton to verify allowable suction pressure.

CAUTION Oil Supply Pressure Control Required

Damage to the pump, filter or other component seals could cause possible oil leakage and potential fire hazard.

- The oil supply inlet pressure to the fuel unit cannot exceed 3 psig.
- Do NOT install valves in return line.
- Ensure that a pressure-limiting device is installed in accordance with the latest edition of the NFPA 31.

If fuel supply is **level with or higher than** fuel unit —

- When the fuel unit is not required to lift the oil, the installation is usually suitable for either a one-pipe or two-pipe oil system. The oil pressure at the inlet of the fuel unit must not exceed 3 psig.
- Refer to the *Mount the Burner* Section of this manual for one-pipe or two-pipe fuel supply installation instructions.

If fuel supply is **below** the fuel unit —

- Use a two-pipe oil system when the fuel unit must lift the oil more than 8 feet if burner is equipped with a **B** fuel unit. The return line provided by the two-pipe system is needed to purge the air from the fuel lines and minimize the likelihood of air-related problems during operation.

☐ Nozzle pressure

WARNING

Correct Nozzle and Flow Rate Required



Incorrect nozzles and flow rates could result in impaired combustion, under-firing, over-firing, sooting, puff-back of hot gases, smoke and potential fire or asphyxiation hazards.

Use only nozzles having the brand, flow rate (gph), spray angle and pattern specified by the appliance manufacturer.

Follow the appliance manufacturer's specifications for the required pump outlet pressure for the nozzle, since this affects the flow rate.

- Nozzle manufacturers calibrate nozzle flow rates at 100 psig.
- This burner utilizes pressures higher than 100 psig, so the actual nozzle flow rate will be greater than the gph stamped on the nozzle body. (Example: A 4.00 gph nozzle at 140 psig = 4.75 gph.)
- For typical nozzle flow rates at various pressures see accompanying chart.

- The fuel unit nozzle port pressure is factory set at 140 psig. Some original equipment manufacturer burner applications may call for a lower pressure to obtain a required firing rate. Do not change this pressure unless directed to do so by the appliance manufacturer.
- See burner nameplate rating label for factory settings and specifications.

☐ Vent system

- The flue gas venting system must be in good condition and must comply with all applicable codes.

☐ Electrical supply

- Verify that the power connections available are correct for the burner. All power must be supplied through fused disconnect switches.

☐ Verify burner components —

- **Burner**, Model CF500 or CF800
- **Air tube assembly**
- **Mounting flange kit**
- **Oil nozzle**, per *Table 1* — Only 45° to 70° solid pattern nozzles are recommended unless otherwise specified by appliance manufacturer. (See specific appliance recommendation sheet or refer to OEM Spec Guide). Find the required firing rate in the 140 psig column (factory-set fuel unit pressure). Select the corresponding nozzle from column 1 (**Rated gph @ 100 psig**).

Table 1 - Nozzle Capacities

Rated gph @ 100 psig	Pressure - Pounds per square inch	
	140	150
1.75	2.07	2.14
2.00	2.37	2.45
2.25	2.66	2.74
2.50	2.96	3.06
2.75	3.24	3.37
3.00	3.55	3.68
3.50	4.13	4.29
4.00	4.70	4.90
4.50	5.30	5.51
5.00	5.90	6.13
5.50	6.50	6.74
6.00	7.10	7.33
6.50	7.65	7.96

Verify firing rate

- Refer to appliance manufacturer’s instructions (if available) for firing rate and nozzle selection. Otherwise, the maximum recommended firing rate for the burner depends on the length of the firing chamber and the distance from the burner center to the chamber floor. Verify that the chamber dimensions are at least as large as the minimum values given in **Figure 1**. If the appliance dimensions are smaller than recommended, reduce the firing rate accordingly.

Figure 1. Min. Combustion Chamber Dimensions

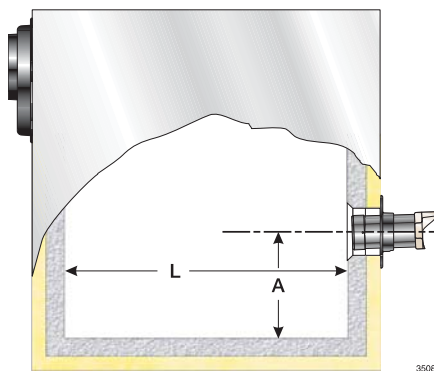

Firing Rate	Minimum Dimensions			
	(with damper)		(without damper)	
	A	L	A	L
1.75 to 3.00 gph	7.5"	18.0"	8.0"	19.0"
4.00 gph	8.0"	21.0"	9.5"	23.0"
5.00 gph	9.0"	23.0"	10.5"	30.0"
6.00 gph	10.0"	28.0"	11.5"	40.0"
7.00 gph	11.0"	34.0"	12.0"	46.0"
8.00 gph	14.0"	38.0"	14.0"	51.0"

Verify air tube

- The information in this section may be disregarded if the air tube is supplied by the appliance manufacturer.
- Two tube arrangements are available –
 CF500 1.75 to 5.50 GPH
 CF800 Tube A — 3.00 to 7.00 GPH
 Tube B — 5.00 to 8.00 GPH
- Maximum firing capacity depends on the firebox pressure. Use **Table 2** to verify the correct air tube type for the firing rate required. Use Tube B only when Tube A cannot provide the firing rate required.
- See **Figure 2** to verify the correct air tube length and air tube combination code.

Figure 2 - Air Tube Mounting Dimensions

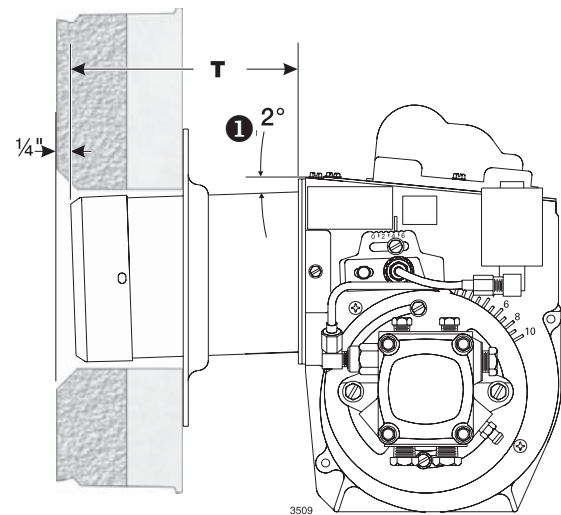

- Install burner with 2° pitch as shown.

Air Tube Length (Dimension T)	A.T.C. Codes (A.T.C. = Air Tube Combination)		
	CF500	CF800	
		Tube A	Tube B
6.00"	CF 60 KK	CF 60 KH	CF 60 KJ
8.00"	CF 80 KK	CF 80 KH	CF 80 KJ
10.00"	CF 100 KK	CF 100 KH	CF 100 KJ
14.00"	CF 140 KK	CF 140 KH	CF 140 KJ
16.00"	CF160 KK	--	--
17.00"	--	CF 170 KH	CF 170 KJ

Mount the burner

Table 2 - Air tube capacities vs firebox pressure

Firebox pressure (in w.c.)	CF500	CF800	
	Tube KK	Tube KH	Tube KJ
	No reserve air		
0.0"	5.50	7.00	8.00
0.1"	4.75	6.25	7.50
0.2"	4.00	5.50	6.75
0.3"	3.50	4.50	6.25
0.4"	2.75	3.75	5.50
0.5"	2.00	3.00	5.00

Note: The above ratings may vary 5% due to variations in actual job conditions.



Protect the Air Tube From Overheating

Overheating could cause damage to the air tube and other combustion components leading to equipment malfunction and impaired combustion performance.

- The end of the air tube must not extend into the combustion chamber unprotected unless it has been factory-tested and specified by the appliance manufacturer.
- Position the end of the air tube 1/4" back from flush with the refractory inside entry wall to prevent damage from overheating.

□ Mount flange(s) on air tube

- This section does not apply to burners with welded flanges.
- Do not install air tube on burner.
- For *non-pressure firing flange*, refer to **Figure 3**: Install gasket (item **a**) and flange (item **d**). Ignore the next paragraph.
- For *pressure-firing flange*, refer to **Figure 3**: Slide gasket (item **a**) onto the air tube, making sure the top of the air tube is up. Pre-drill holes in the pressure firing plate (item **b**) to match the appliance studs. Slide the pressure firing plate (item **b**) and flange (item **d**) onto the air tube as shown. Wrap ceramic fiber rope (item **c**) around the air tube and press tightly into the inside diameter of the flange (item **d**).
- Slide the air tube (item **e**) into position in the appliance front. Tighten the flange-mounting-stud nuts. Set the insertion of the air tube so dimension **G** is 1/4" nominal.
- Pitch the air tube at 2° from horizontal as shown and secure the flange to the air tube.

Figure 3 - Mount flange(s) on air tube

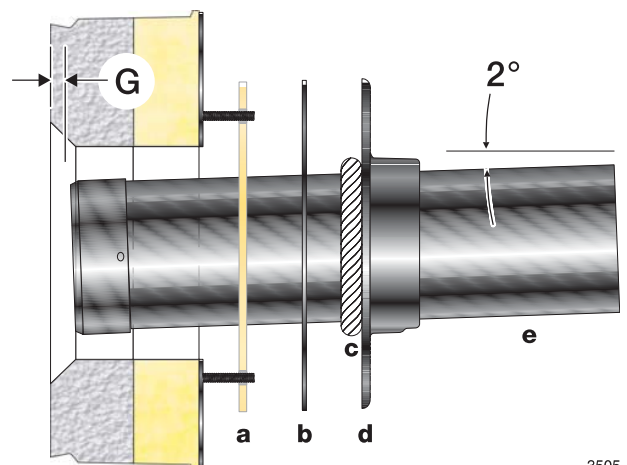

3505

Mount air tube to burner

- Insert the air tube into the burner housing. Carefully align the the four screw holes.
- Attach the air tube to the burner using the four provided screws.

Install nozzle

- Install the oil nozzle in the nozzle adapter. Use a 3/4" open-end wrench to steady the nozzle adapter and a 5/8" open-end wrench to turn the nozzle. Tighten securely but do not over-tighten.

Check electrode settings

WARNING **Maintain Electrode Specifications**

Failure to properly maintain these specifications could cause ignition malfunction, puff-back of hot gases, heavy smoke, asphyxiation, explosion and fire hazards.

- Adjust the electrode gap and position in relation to the nozzle to the specifications shown in Figure 4.
- Check, and adjust if necessary, the critical dimensions shown in **Figure 4**. Verify that the oil tube assembly and electrodes are in good condition, with no cracks or damage.

Figure 4 - Nozzle and nozzle line assembly

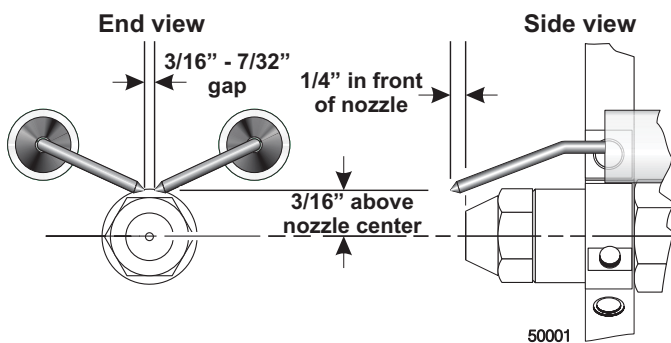

Install nozzle line assembly

- Insert the nozzle line assembly into the burner air tube. Reference **Figure 5**.
- Slide the secondary adjusting plate (**Figure 6**, item **f**) completely to the left on the indicator adjusting plate (item **e**). Finger tighten acorn nut (item **c**) to secure the two plates together. Slide both plates completely to the right (Indicator Plate will read 0). Tighten fastener (item **d**).
- Install the spline nut on the end of the nozzle line, leaving the nut loosely placed so the plates can be moved.

Figure 5 - Nozzle line assembly in burner

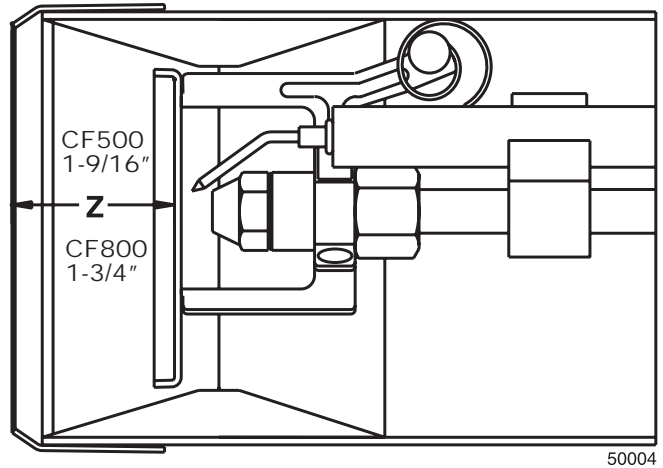

Set dimension Z

- Loosen fastener **c** in **Figure 6**. Slide the nozzle line and plate assembly until dimension **Z** in **Figure 5** is:
CF500 - 1-9/16" ±1/16"
CF800 - 1-3/4" ±1/16".
 When dimension **Z** (from end of air tube to flat area of front face of head) is correctly set, tighten acorn nut (item **c**).
- Attach the oil line from the oil valve to the nozzle line end. Tighten securely.
- Before proceeding, check dimension **Z** once again. Loosen acorn nut **c** if necessary to reposition the nozzle line. Once dimension **Z** is set, **do not loosen the acorn nut (item c) again**. Note that for the setting of fastener **d**, refer to *Initial Head Position* procedure on Page 11.

Figure 6 - Adjusting plate assy.

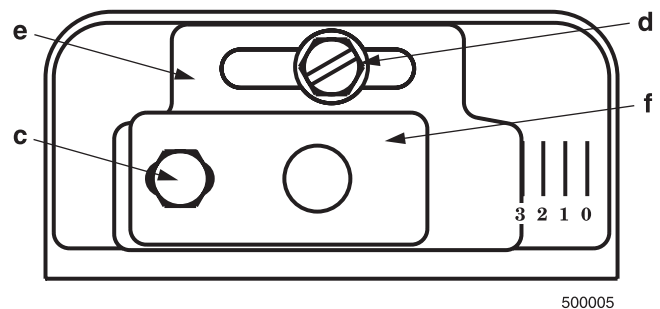

Legend (Figures 5 and 6)

- | | | | |
|---|------------------|---|---------------------------|
| c | Bottom acorn nut | e | Indicator adjusting plate |
| d | Fastener | f | Secondary adjusting plate |

Insert burner

- Position the burner in the front of the appliance and loosely tighten the nuts on the mounting studs. The burner should be pitched downward 2° as shown in **Figure 3**.
- Secure the burner to the appliance by tightening the nuts on the burner flange mounting studs.

□ Fuel unit by-pass plug



WARNING Do Not Install By-pass Plug with 1-Pipe System

Failure to comply could cause immediate pump seal failure, pressurized oil leakage and the potential for a fire and injury hazard.

- The burner is shipped *without* the by-pass plug installed.
- Install the by-pass plug in two-pipe oil supply systems **ONLY**.

- The CF500 and CF800 burners are shipped without the by-pass plug installed in the fuel line.
- The by-pass plug must **NOT** be installed when using with a one-pipe oil system.
- The by-pass plug **MUST** be installed when using a two-pipe oil system.

Connect fuel lines

□ Oil supply/return lines



WARNING Install Oil Supply To Specifications



Failure to properly install the oil supply system could cause oil leakage, equipment malfunction, puff-back of hot gases, heavy smoke, asphyxiation, explosion and fire hazards.

- Carefully install the oil supply lines, fittings and components using the guidelines provided in this section.
- The oil supply must comply with the latest edition of NFPA 31 (Canada CSA B139) and all applicable codes.
- Do **NOT** install valves in return lines.
- If the oil supply inlet pressure to the pump exceeds 3 psig or for gravity feed systems, install an oil safety or pressure reducing valve (Webster OSV, Suntec PRV or equivalent).

- Install the oil tank and oil lines in accordance with all applicable state and local codes.
- Size the oil supply and return lines using the guidelines given in the fuel unit literature included in the literature envelope. Oil line flow rate will equal the burner rate for one-pipe systems. For two-pipe systems, refer to **Table 2** for the fuel unit gear set capacity - the rate at which fuel is recirculated when connected to a two-pipe system. However, size two-pipe oil lines based on this flow rate.
- Use continuous lengths of heavy-wall copper tubing, routed under the floor where possible. Do not attach fuel lines to the appliance or to floor joists if possible. This will reduce vibration and noise transmission problems.
- Install an oil filter sized to handle the fuel unit gearset flow capacity (**Table 2**) for **two-pipe systems**. Size the filter

Table 3. Fuel Unit gearset capacity

Fuel unit model number	Gearset capacity (GPH)
A2VA-7116	17
A2YA-7916	20
B2VA-8216	21
B2YA-8916	25
B2TA-8248	21

for the firing rate for **one-pipe systems**. Locate the filter immediately adjacent to the burner fuel unit.

- Install two high-quality shut-off valves in accessible locations on the oil supply line. Locate one valve close to the tank. Locate the other valve close to the burner, upstream of the fuel filter.

□ Burner fuel flow

- **One-pipe systems** – See **Figure 7** for the fuel flow path.
 - **Figure 7** is based on type **B** fuel unit.
 - Oil supply connects to one of the fuel unit inlet ports.
- **Two-pipe systems** – See **Figure 8** for the fuel flow paths for two-pipe oil systems.
 - **Figure 8** is based on type **B** fuel unit .
 - Oil supply connects to one of the fuel unit inlet ports. Oil return connects to the fuel unit return port. (**Install the by-pass plug in the fuel unit for two-pipe systems.**)
- **Nozzle pressure** – The fuel unit nozzle port pressure is factory set at 140 psig. Some original equipment manufacturer burner applications may call for a lower pressure to obtain a required firing rate. Do not change this pressure unless directed to do so by the appliance manufacturer.

Figure 7 - One-pipe oil flow with “B” pump

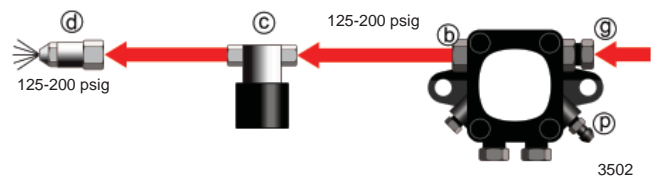
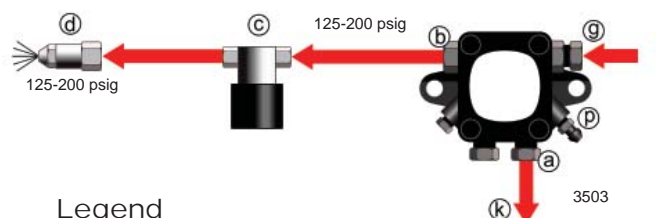

Figure 8 - Two-pipe oil flow with “B” pump



Legend

- a Return port
- b Nozzle port
- c Oil valve
- d Nozzle & adapter
- g Inlet port
- k Return line to oil tank
- p Air bleed valve

Wire the burner — R7184

WARNING Electrical Shock Hazard

Electrical shock can cause severe personal injury or death.

- Disconnect electrical power before installing or servicing the burner.
- Provide ground wiring to the burner, metal control enclosures and accessories. (This may also be required to aid proper control system operation)
- Perform all wiring in compliance with the National Electric Code ANSI/NFPA 70 (Canada CSA C22.1).

Install the burner and all wiring in accordance with the National Electrical Code and all applicable local codes or requirements.

Wire the burner in compliance with all instructions provided by the appliance manufacturer. Verify operation of all controls in accordance with the appliance manufacturer’s guidelines.

See **Figure 9** for a typical wiring diagram, with R7184 oil primary, for reference purposes only.

Figure 9. - Typical wiring

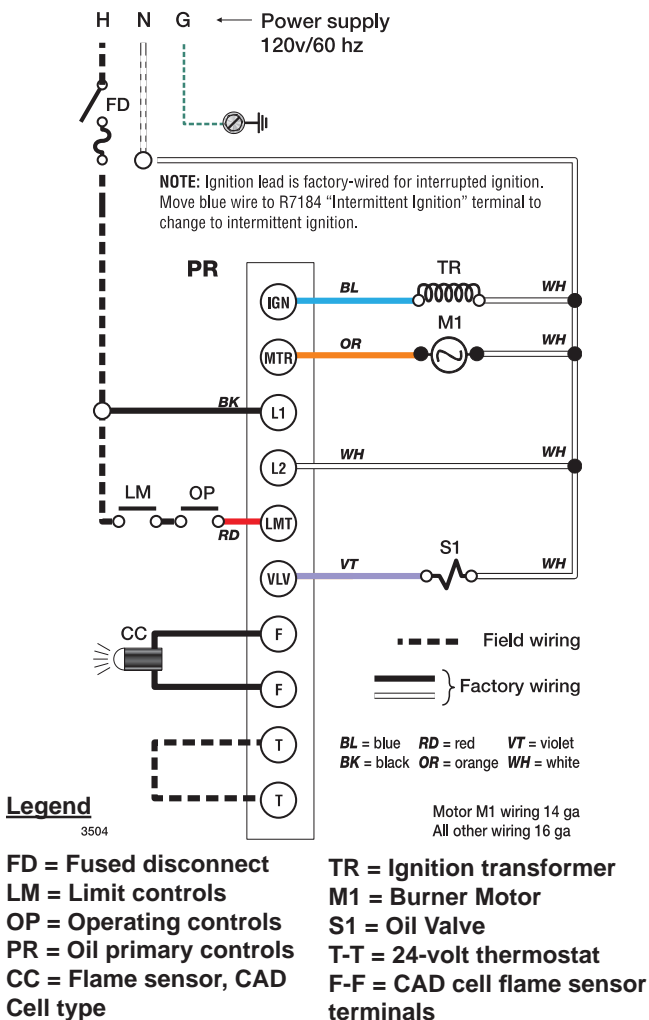

Prepare the burner for start-up

WARNING Professional Installation and Service Required

Incorrect installation and mishandling of start-up could lead to equipment malfunction and result in asphyxiation, explosion or fire.

- This burner must be installed and prepared for start-up by a qualified service technician who is trained and experienced in commercial oil burner system installation and operation.
- Do not attempt to start the burner unless you are fully qualified.
- Do not continue with this procedure until all items in the “Prepare the burner for start-up” section have been verified.
- Carefully follow the wiring diagrams, control instruction sheets, flame safeguard sequence of operation, test procedures and all appliance manufacturer’s directions that pertain to this installation.
- If any of these items are not clear or are unavailable, call Beckett at 1-800-645-2876 for assistance.

WARNING Do Not Bypass Safety Controls

Tampering with, or bypassing safety controls could lead to equipment malfunction and result in asphyxiation, explosion or fire.

- Safety controls are designed and installed to provide protection.
- Do not tamper with, or bypass any safety control.
- If a safety control is not functioning properly, shut off all main electrical power and fuel supply to the burner and call a qualified service agency immediately.

CAUTION Keep Service Access Covers Securely Installed

These covers must be securely in place to prevent electrical shock, damage from external elements, and protect against injury from moving parts.

- All covers or service access plates must be in place at all times except during maintenance and service.
- This applies to all controls, panels, enclosures, switches, and guards or any component with a cover as part of its design.

Start-up checklist

- Combustion air supply and venting have been inspected and verified to be free of obstructions and installed in accordance with all applicable codes.
- Oil nozzle has been selected correctly and securely installed in the nozzle adapter.
- Fuel unit by-pass plug **has not** been installed for one-pipe oil system.
- By-pass plug **has been** installed for two-pipe oil system.
- Fuel connection to nozzle line assembly is secure.
- Dimension Z has been set per this instruction manual.
- Fuel supply line is correctly installed, the oil tank is sufficiently filled, and shut-off valves are open.
- Burner is securely mounted in appliance, with pressure firing plate and gasket installed for pressurized chamber application.
- Appliance has been filled with water (boilers) and controls have been operationally checked.
- Burner has been installed in accordance with appliance manufacturer's instructions (when available).
- Also refer to appliance manufacturer's instructions (when available) for start-up procedures.
- Z dimension

Should be set per the Set Z Dimension instructions detailed earlier in this manual. The acorn nut (**Figure 6**, item **c**) should never be loosened once the Z dimension is initially set.

Initial head position (Figure 6)

- The indicator plate assembly markings correspond to head position settings.
- Loosen the fastener (**Figure 6**, item **d**) and slide the indicator plate until the number on the indicator plate corresponds to the initial head setting listed in **Table 3**, for the desired firing rate.
- When the head position has been set, tighten the fastener and the spline nut.

Initial air settings (Table 4)

- Loosen the air band and shutter, and adjust to the approximate firing rate settings given in **Table 4**.
- These initial settings should be adequate for starting the burner. Once the burner is in operation, the air settings will be adjusted for best performance as discussed later in this manual.
- Follow the procedures described later in this manual for fine-tuning the air settings.

Set appliance limit controls

- Set the appliance limit controls in accordance with the appliance manufacturer's recommendations.

Prepare the fuel unit for air venting

- To vent air from the oil supply line, attach a clear hose to the vent plug on the fuel unit. Provide a container to catch the oil. Loosen the vent plug.
- Vent the air as described in the next section under **Start the burner**.

Table 4 - Initial indicator adjustment plate settings (head position)

Rate GPH	Approximate head settings		
	CF500	CF800	
		Tube A	Tube B
1.75"	0	--	--
2.25"	0		
3.00"	4	0	--
3.50"	5	1	--
4.00"	5	2	--
5.00"	6	4	3
5.50"	6	4	4
6.00"	--	4	4
7.00"	--	6	5
8.00"	--	--	6

Table 5 - Initial air shutter and band settings

Rate GPH	Approximate air settings					
	CF500		CF800			
	Shutter	Band	Tube A		Tube B	
Shutter			Band	Shutter	Band	
1.75"	1	0	--	--	--	--
2.25"	2	0	--	--	--	--
3.00"	10	1	1	0	--	--
3.50"	10	2	3	0	--	--
4.00"	10	3	4	0	--	--
5.00"	10	5	9	0	8	2
5.50"	10	10	9	5	9	4
6.00"	--	--	10	3	10	3
7.00"	--	--	10	8	10	5
8.00"	--	--	--	--	10	10

Start the Burner



WARNING

Explosion and Fire Hazard



Failure to follow these instructions could lead to equipment malfunction and result in heavy smoke emission, soot-up, hot gas puff-back, fire and asphyxiation hazards.

- Do not attempt to start the burner when excess oil has accumulated in the appliance, the appliance is full of vapor, or when the combustion chamber is very hot.
- Do not attempt to re-establish flame with the burner running if the flame becomes extinguished during start-up, venting, or adjustment.
- **Vapor-Filled Appliance:** Allow the unit to cool off and all vapors to dissipate before attempting another start.
- **Oil-Flooded Appliance:** Shut off the electrical power and the oil supply to the burner and then clear all accumulated oil before continuing.
- If the condition still appears unsafe, contact the Fire Department. Carefully follow their directions.
- Keep a fire extinguisher nearby and ready for use.

□ Starting the burner and venting air

Priming the pump

- Initiate a call for heat
- While the ignition is on, press and release the reset button on the R7184 control (hold 1/2 second or less). If the control has not locked out since it's most recent complete heat cycle, the lockout time will be extended to 4 minutes (45 seconds in earlier units), and the ignition will remain on the entire heat cycle.
- Bleed the pump until all froth and bubbles are purged. If prime is not established within the extended lockout time, the control will lock out. Press the reset button to reset the control and return to the functions listed in the previous step.



WARNING

Hot Gas Puff-back and Heavy Smoke Hazard



Failure to bleed the pump properly could result in unstable combustion, hot gas puff-back and heavy smoke.

- Do not allow oil to intermittently spray into a hot combustion chamber while bleeding.
- Install a gauge in the nozzle discharge port tubing or fully open the pump bleed valve to prevent oil spray from accumulating in the combustion chamber when venting air from the fuel pump.
- Ensure that all bubbles and froth are purged from the oil supply system before tightening the pump air bleed valve.

- Repeat the previous steps if needed, until the pump is fully primed and the oil is free of bubbles. Then terminate the call for heat, and the control will resume normal operation.

Resetting from restricted lockout

- If the control locks out three times in a row without a complete heat cycle between attempts, the lockout becomes restricted. A qualified service technician should be called to inspect the burner.

Disable function

- Any time the motor is running, press and hold the reset button to disable the burner. The burner will remain off as long as the button is held and will return to standby when released

CAD cell resistance check

- While the burner is firing, and after the ignition has been turned off, press and release the reset button (hold 1/2 second or less) to check the cad cell resistance. The LED will flash 1 to 4 times, depending on the cad cell resistance (refer to the table below).

Number of LED Flashes	Cad Cell Resistance (ohms)
1	Normal (0 to 400)
2	Normal (400 to 800)
3	Normal (800 to 1600)
4	Limited (1600 to Lockout)*

* Lockout can occur above 4000 ohms.

LED Indicator	Status
On	Flame sensed
Off	Flame not sensed
Flashing (1/2 sec off - 1/2 sec on)	Lockout/Restricted Lockout
Flashing (2 sec off - 2 sec on)	Recycle

□ Set combustion using instruments

1. Allow the burner to run for approximately 5 to 10 minutes.
2. Set the stack or over-fire draft to the level specified by the appliance manufacturer.
 - **Natural Draft Applications;** typically over-fire draft is -0.01" or -0.02" w.c.
 - **Direct Venting;** typically may not require draft adjustment.
 - **High Efficiency/Positive Pressure Appliances;** also vary from traditional appliances (see manufacturer's recommendations).
3. Follow these four steps to properly adjust the burner:

Step 1: Adjust the air shutter/band until a trace of smoke is achieved.

Step 2: At the trace of smoke level, measure the CO₂ (or O₂). This is the vital reference point for further adjustments. Example: 13.5% CO₂ (2.6% O₂)

Step 3: Increase the air to reduce the CO₂ by 1.5 to 2 percentage points. (O₂ will be increased by approximately 2.0 to 2.7 percentage points.) Example: Reduce CO₂ from 13.5% to 11.5% (2.6% to 5.3% O₂).

Step 4: Recheck smoke level. It should be Zero.

- This procedure provides a margin of reserve air to accommodate variable conditions.
 - If the draft level has changed, recheck the smoke and CO₂ levels and readjust the burner, if necessary
4. Once combustion is set, tighten all fasteners on air band, air shutter and escutcheon plate.
 5. Start and stop the burner several times to ensure satisfactory operation. Test the primary control and all other appliance safety controls to verify that they function according to the manufacturer's specifications.
 6. Check the breech draft pressure against the appliance manufacturer's recommended setting (typically + 0.1" W.C.). If the breech pressure is higher or lower than recommended level, adjust the appliance breech damper to achieve the specified setting. Recheck the smoke and CO₂ levels. Adjust burner air if necessary.

Sequence of operation — typical

1. **Standby** — The burner is idle, waiting for a call for heat. When a call for heat is initiated, there is a 3- to 10-second delay while the control performs a safe start check.
2. **Valve-on delay** — As applicable, the ignition and motor are turned on for a 15-second prepurge.
3. **Trial for ignition (TFI)** — The fuel valve is opened, as applicable. A flame should be established within the 15-second lockout time (30-second lockout time is available).
4. **Lockout** — If flame is not sensed by the end of the TFI, the control shuts down on safety lockout and must be manually reset. If the control locks out three times in a row, the control enters restricted lockout. Call a qualified service technician.
5. **Ignition carryover** — Once flame is established, the ignition remains on for 10 seconds to ensure flame stability. It then turns off.
6. **Run** — The burner runs until the call for heat is satisfied. The burner is then sent to burner motor-off delay, as applicable, or it is shut down and sent to standby.
7. **Recycle** — If the flame is lost while the burner is firing, the control shuts down the burner, enters a 60-second recycle delay, and then repeats the ignition steps outlined above. If the flame is lost three times in a row, the control locks out to prevent continuous cycling with repetitious flame loss caused by poor combustion.
8. **Burner motor-off delay** — If applicable, the fuel valve is closed and the burner motor is kept on for the selected postpurge time before the control returns the burner to standby.

Figure 10. - Typical sequence of operation

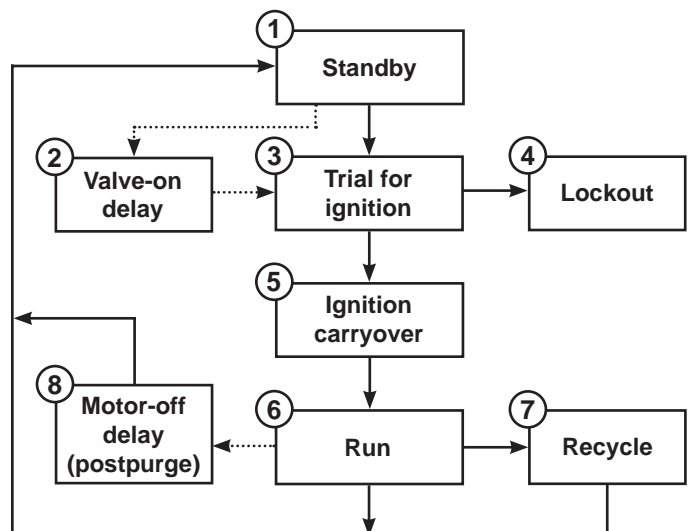

Maintenance and Service



WARNING

Annual Professional Service Required



Tampering with or making incorrect adjustments could lead to equipment malfunction and result in asphyxiation, explosion or fire.

- Do not tamper with the burner or controls or make any adjustments unless you are a trained and qualified service technician.
- To ensure continued reliable operation, a qualified service technician must service this burner annually.
- More frequent service intervals may be required in dusty or adverse environments.
- Operation and adjustment of the burner requires technical training and skillful use of combustion test instruments and other test equipment.

Annual service — by qualified service technician

Have the burner inspected, tested and started at least annually by a qualified service technician. This annual test/inspection should include at least the following:

- Replace the oil supply line filter. The line filter cartridge must be replaced to avoid contamination of the fuel unit and nozzle.
- Inspect the oil supply system. All fittings should be leak-tight. The supply lines should be free of water, sludge and other restrictions.
- Remove and clean the pump strainer if applicable.
- Replace the nozzle with the exact brand, pattern, gph, flow rate and spray angle.
- Clean and inspect the electrodes for damage, replacing any that are cracked or chipped.
- Check electrode tip settings. Replace electrodes if tips are rounded.
- Inspect the igniter spring contacts.
- Clean the cad cell lens surface, if necessary.
- Inspect all gaskets. Replace any that are damaged or would fail to seal adequately.
- Inspect the combustion head and air tube. Remove any carbon or foreign matter. Replace all damaged units with exact parts.
- Clean the blower wheel, air inlet, air guide, burner housing and static plate of any lint or foreign material.
- If motor is not permanently lubricated, oil motor with a few drops of SAE 20 nondetergent oil at each oil hole. DO NOT over oil motor. Excessive oiling can cause motor failure.

- Check motor current. The amp draw should not exceed the nameplate rating.
- Check all wiring for secure connections or insulation breaks.
- Check the pump pressure and cutoff function.
- Check primary control safety lockout timing.
- Check ignition system for proper operation.
- Inspect the vent system and chimney for soot accumulation or other restriction.
- Clean the appliance thoroughly according to the manufacturer's recommendations.
- Check the burner performance. Refer to the section "Set combustion with test instruments".
- It is good practice to make a record of the service performed and the combustion test results.

Monthly maintenance — by owner

- Observe combustion air openings and vent system for integrity. Openings must be clean and free of obstructions.
- Check oil lines and fittings to verify there are no leaks.
- Observe burner ignition and performance to verify smooth operation.
- Shut the system down if you observe abnormal or questionable operation. Call a qualified service agency for professional inspection and service.

Figure 11 - Adjustable mounting plates for CF500 and CF800

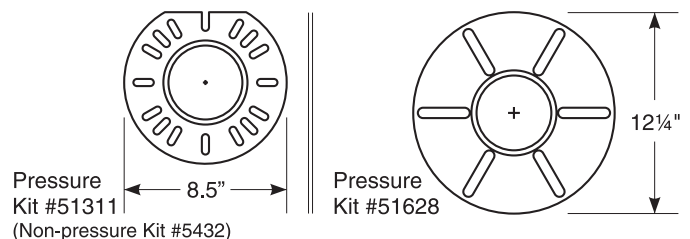

Replacement parts

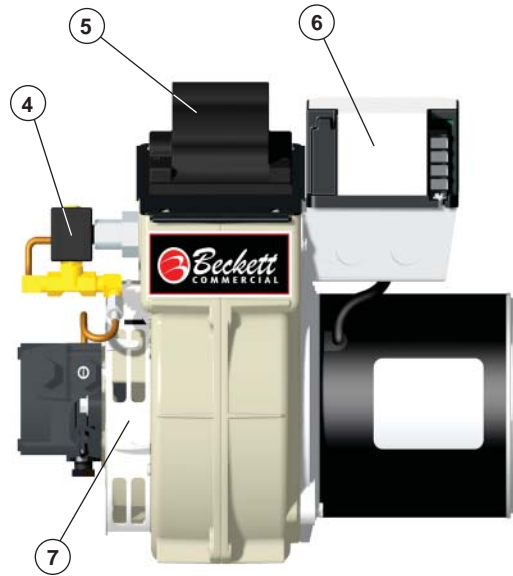
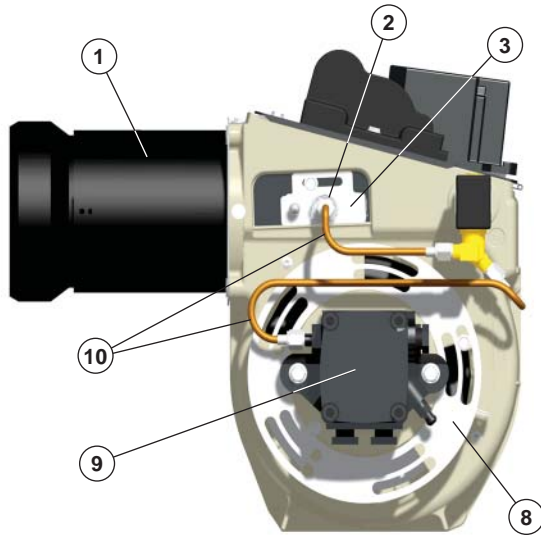

Item	Part Name/Description	Part Number
1	Air Tube	Specify
2	Spline Nut	3666
3	Adjusting plate assembly	51286U
4	Blocking Oil Solenoid Valve	2182602U
5	Igniter	51771U
6	Control	Specify
7	Air Band	3819
8	Air Shutter	3215
9	Fuel Pump	Specify
10	Fuel lines	Specify Lengths
11	Head Assembly: CF500 - KK CF800 - KH (Tube A) CF800 - KJ (Tube B)	51401U 51252P 51302P
12	Electrode Assembly	Specify
13	Nozzle Line Assembly	Specify
14	Motor - 1/3 PSC	21341U
15	Blower Wheel: CF500 - 5-19/32" x 2-13/32" CF800 - 6-5/16" x 2-3/8"	21448U 21339U
16	Coupling	2433
17	Flange Kit	See Figure 11
18	Pedestal Kit	Not Shown

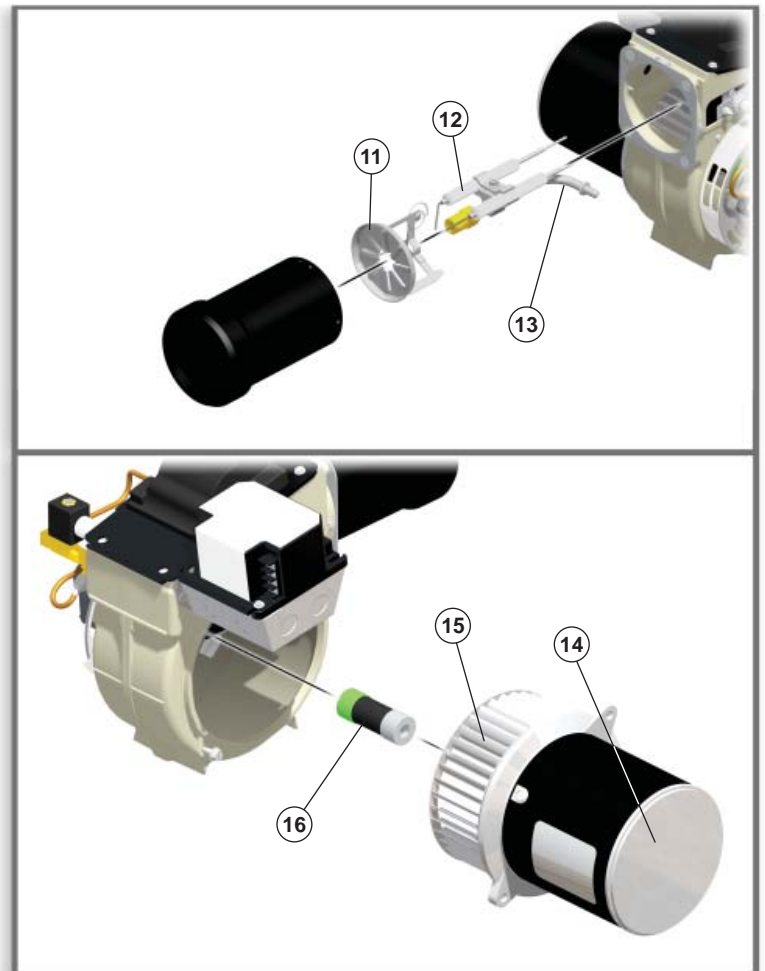

Limited Warranty Information

Limited WARRANTY

For Residential, Commercial and Specialty Burners

The R. W. BECKETT CORPORATION ("Beckett") warrants to persons who purchase its Beckett burners from Beckett for resale or for incorporation into a product for resale ("Customers") that its equipment is free from defects in material and workmanship under normal use and service for 60 months from the date of manufacture for Residential Burners and 18 months from the date of manufacture for Commercial and Specialty Burners. *Residential burner models include:* AF, AFG, AFIL, NX, SF, SR and SMG. *Commercial burner models include:* CF375, CF500, CF800, CF1400, CF2300A, CF2500, CF3500A, CG10, CG15, CG25 and CG50. *Specialty burner models include:* ADC, ADCP, ARV, SDC and SM. The provisions of this warranty are extended to individual major burner components as follows:

- a) 60 months from date of manufacture for all Beckett-branded major components, except for 12 Vdc components.
- b) 18 months from date of manufacture for all non-Beckett-branded major components and Beckett branded 12 Vdc components.

Note: Normal service items found to be defective upon receipt by the customer are covered by this warranty.

THIS WARRANTY DOES NOT EXTEND TO EQUIPMENT SUBJECTED TO MISUSE, NEGLIGENCE, OR ACCIDENT; NOR DOES THIS WARRANTY APPLY UNLESS THE PRODUCT COVERED BY IT IS PROPERLY INSTALLED BY A QUALIFIED, COMPETENT TECHNICIAN, WHO IS LICENSED WHERE STATE AND LOCAL CODES REQUIRE, AND WHO IS EXPERIENCED IN MAKING SUCH INSTALLATIONS, IN ACCORDANCE WITH THE LATEST EDITION OF NFPA NO. 31 OF THE NATIONAL FIRE PROTECTION ASSOCIATION, THE LATEST EDITION OF THE NATIONAL FUEL GAS CODE (NFPA NO. 54) AND IN ACCORDANCE WITH ALL APPLICABLE LOCAL, STATE AND NATIONAL CODES HAVING JURISDICTIONAL AUTHORITY.

Equipment, which is defective in material or workmanship and within the warranty period, may be returned for credit as follows:

Beckett Burners, Beckett-branded major components and non-Beckett-branded major components that came as original equipment on a Beckett burner or were sold as a replacement part by Beckett should be returned, freight prepaid, to Beckett's home office. Credit will be issued to the customer unless the returned equipment is determined by Beckett to be out of warranty or damaged by user, in which case the equipment will be scrapped.

Note: Beckett is not responsible for any labor cost for removal and replacement of equipment.

THIS WARRANTY IS LIMITED TO THE PRECISE TERMS SET FORTH ABOVE, AND PROVIDES EXCLUSIVE REMEDIES EXPRESSLY IN LIEU OF ALL OTHER REMEDIES, AND IN PARTICULAR THERE SHALL BE EXCLUDED THE IMPLIED WARRANTIES OF MERCHANTABILITY AND FITNESS FOR A PARTICULAR PURPOSE. IN NO EVENT WILL BECKETT BE LIABLE FOR ANY INCIDENTAL OR CONSEQUENTIAL DAMAGE OF ANY NATURE. Beckett neither assumes nor authorizes any person to assume for Beckett any other liability or obligation in connection with the sale of this equipment, Beckett's liability and Customer's exclusive remedy being limited to credit as set forth above.

R.W. BECKETT CORPORATION

P.O. Box 1289 Elyria, Ohio 44036

Form No. 61545 R72905

R.W. BECKETT CORPORATION

U.S.A.: P.O. Box 1289 · Elyria, Ohio 44036

www.beckettcorp.com

Canada: R.W. Beckett Canada, Ltd. · Unit #3, 430 Laird Road · Guelph, Ontario N1G 3X7

Printed in U.S.A. 12/2006 © R.W. Beckett Corporation

Part Number 6104BCF5 R06