



# COMBUSTION AIR SYSTEM

Model: CAS-2A



This product is designed for use on the following burners, for the purpose of routing combustion air directly to the burner, with the added safety feature of the vacuum relief valve.  
**NOTE:** For burner inputs up to 2.0 GPH at 100 PSI input pressure or equivalent.

"The Air Boot™ model CAS-2A is for use only on the designated burner(s) as described in these instructions only when the specific burner includes this Air Boot™ when shipped from the burner manufacturer or where the burner instructions specifically reference the models CAS-2A Air Boot™ as an optional air intake system."

## AERO MODELS

F-AFC      HF-AFC  
HF-US      SV SERIES

### ITEMS INCLUDED IN KIT:

- 1 - Air Boot™
- 1 - 4" VRV
- 1 - 4" IAH Hood
- 1 - Burner Coupling Set
- 2 - Mounting Bolts

### INSTALLER SUPPLIED ITEMS:

- Duct Piping and Elbows
- 90° Elbows;
- 1/4" NPT Female x 1/4" NPT Male for routing oil line



**FIELDCONTROLS**  
THE VENTING SOLUTIONS COMPANY

2630 Airport Road • Kinston, NC 28504  
Phone: 252-522-3031 • FAX: 252-522-0214  
[www.fieldcontrols.com](http://www.fieldcontrols.com)

## THE PURPOSE OF THE VRV

The Vacuum Relief Valve is a safety device to guard against combustion problems associated with directly connecting oil burners to the outside. Typical problems can be caused by blockage of the intake termination, icing up of the duct work and effects of leeward side wind effects on a building.

## VRV OPERATION

The VRV gate operates on changes in the vacuum pressure generated by the inlet to the oil burner. The VRV gate will remain closed during normal burner operation. During an abnormal operation (i.e., blockage of the intake or change in external building pressures) an increased negative pressure on the intake of the burner causes a reduction in burner air flow. Under this condition, the VRV gate opens, stabilizing and maintaining proper air flow to the burner. The VRV gate closes again once the abnormal condition is corrected.

## INSTALLATION

1. Remove the oil pump and air bands from the burner housing. Position the Air Boot™ over the burner housing on the intake. Align the holes in the Air Boot™ with the holes in the housing and re-attach the oil pump. (See Figure 1) **NOTE:** *Replace pump coupling with the coupling supplied with kit.* Mount VRV tee assembly or 90° elbow onto the Air Boot™ intake. Fasten using three (3) sheet metal screws on all joints. (See Figure 2)

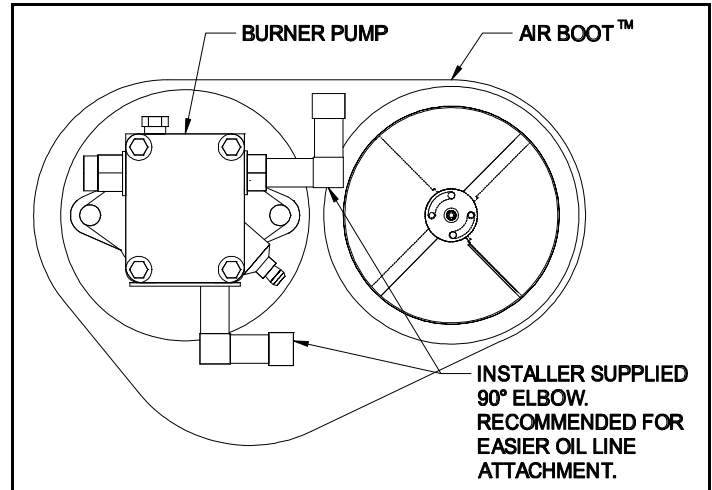

Figure 1

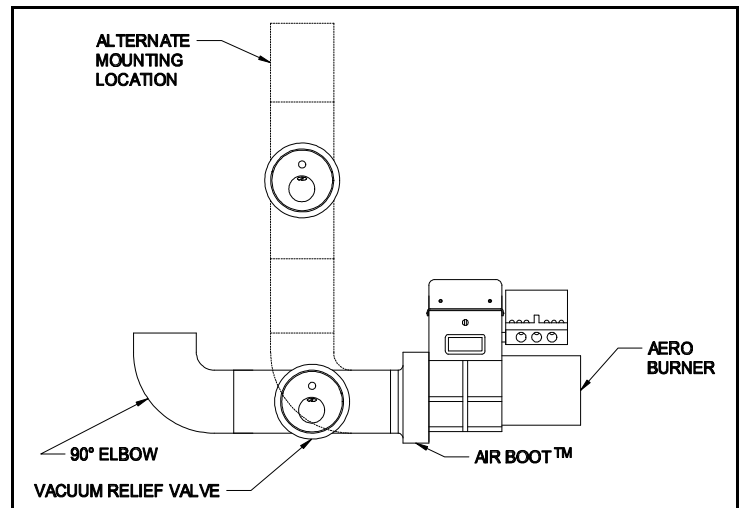
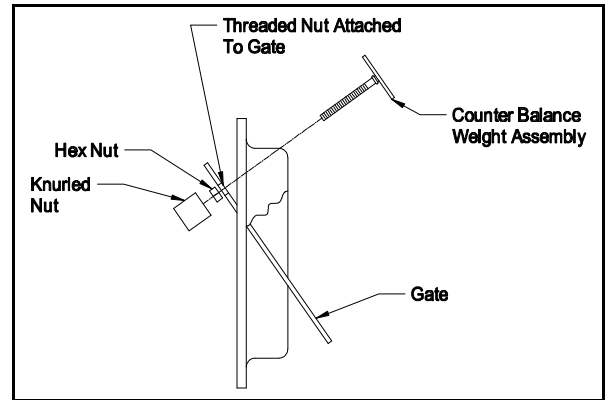

Figure 2

2. Assemble VRV balance weight onto the gate. Screw the weight all the way in. Then attach lock nut and knurl nut. (See Figure 3)
3. Mount the VRV assembly onto the tee and fasten with a screw and nut in collar tabs. To ensure proper operation, check the gate for being level across the pivot points and plumb. (See Figure 4)
4. Refer to Figure 5 for general installation layout.



**Figure 3**

**TERMINATION LOCATION GUIDELINES**

1. Mount intake hood 12 inches above finished grade. If mounting on the side of a building prone to drifting snow, mount 12 inches above the snow line.
2. Mount at least 12 inches from either side of the vent termination and on the same wall if sidewall venting.
3. Always mount with the inlet vent termination opening pointing down.

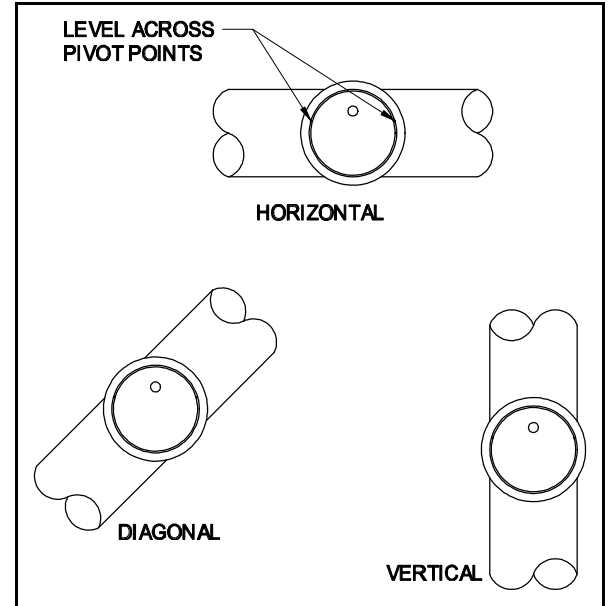

**Figure 4**

**INLET VENT TERMINATION INSTALLATION**

1. Cut a 4-1/4" diameter hole through the sidewall of the building.
2. Slide the inlet vent pipe through the hole and fasten to the wall with appropriate fasteners. Seal the edges of the mounting plate with a silicone sealant or equivalent.

**DUCT WORK INSTALLATION**

1. Duct length distance, a maximum of 30 linear feet of standard duct pipe and two (2) 90° elbows. Subtract 7 feet from the maximum linear feet for every 90° elbow added. Maximum linear footage will be less for flex duct. Consult flex duct manufacturer for equivalent lengths.

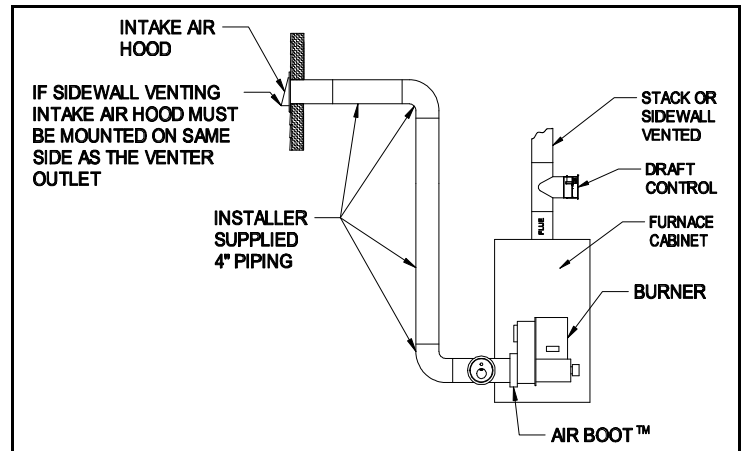

**Figure 5**

Longer pipe lengths require the use of a larger pipe between the VRV and the intake hood. It also requires the use of a vent pipe increaser at the VRV and a reducer at the intake hood. (See Table 1)

**Table 1**

<i>Pipe Diameter</i>	<i>Maximum Equivalent Pipe Feet (between Air boot™ and duct termination)</i>	<i>Elbow* Equivalent Feet</i>	<i>Reducer or Increaser Equivalent Feet</i>
4"	44'	7'	-
5"	60'	9'	(4" to 5") 3'
6"	90'	11'	(4" to 6") 6'

\*Note: Subtract the elbow or reducer equivalent feet from the maximum equivalent feet to get maximum linear feet of pipe

2. Route the duct work from the VRV tee to the inlet vent termination with as minimum a number of elbows as possible.
3. Secure and support the duct work for the design and weight of the material used, to prevent physical damage and separation of joints. For guidelines refer to recognized national building codes or according to any local codes.
4. To reduce uncontrolled air leakage into the duct, tape all joints and seams using standard duct tape.

**NOTE:** To prevent sweating on the outside of the duct, when operating in areas that have -10°F or below design temperatures, insulate the duct work at least 10 feet from the inlet vent termination.

**AIR ADJUSTMENT**

1. Adjust the air adjustment knob on the side of the Air Boot™ (See Table 2) to rough air setting.

**Table 2**

<b>ROUGH AIR SETTING</b>	
<i>GPH</i>	<i>Knob Setting</i>
.75	70°
1.00	90°
1.50	135°

2. Start the burner and adjust the air control as needed to achieve the required CO<sub>2</sub> and smoke levels. Set over fire draft to appliance manufacturers' specifications (typically -.02" of water). Secure air control knob with indicator bracket. If draft levels are not obtainable or controllable, use standard industry methods to control the draft or call the Field Controls Tech Line at 1-800-742-8368 for more information.
3. Next, adjust the VRV gate by screwing the adjustment weight in until the VRV gate is just closed.
4. Re-check the burners operation and adjust accordingly.
5. Lock the adjustment weight in position by tightening the hex nut on the VRV gate.

