

# WESLO<sup>®</sup> cadence DX8

Model No. WLTL46090

Serial No. \_\_\_\_\_

Write the serial number in the space above for future reference.

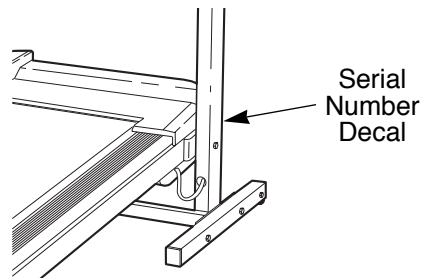

## QUESTIONS?

As a manufacturer, we are committed to providing complete customer satisfaction. If you have questions, or if there are missing or damaged parts, we will guarantee complete satisfaction through direct assistance from our factory.

**TO AVOID UNNECESSARY DELAYS, PLEASE CALL DIRECT TO OUR TOLL-FREE CUSTOMER HOT LINE.** The trained technicians on our customer hot line will provide immediate assistance, free of charge to you.

**CUSTOMER HOT LINE:**

**1-800-999-3756**

Mon.-Fri., 6 a.m.-6 p.m. MST

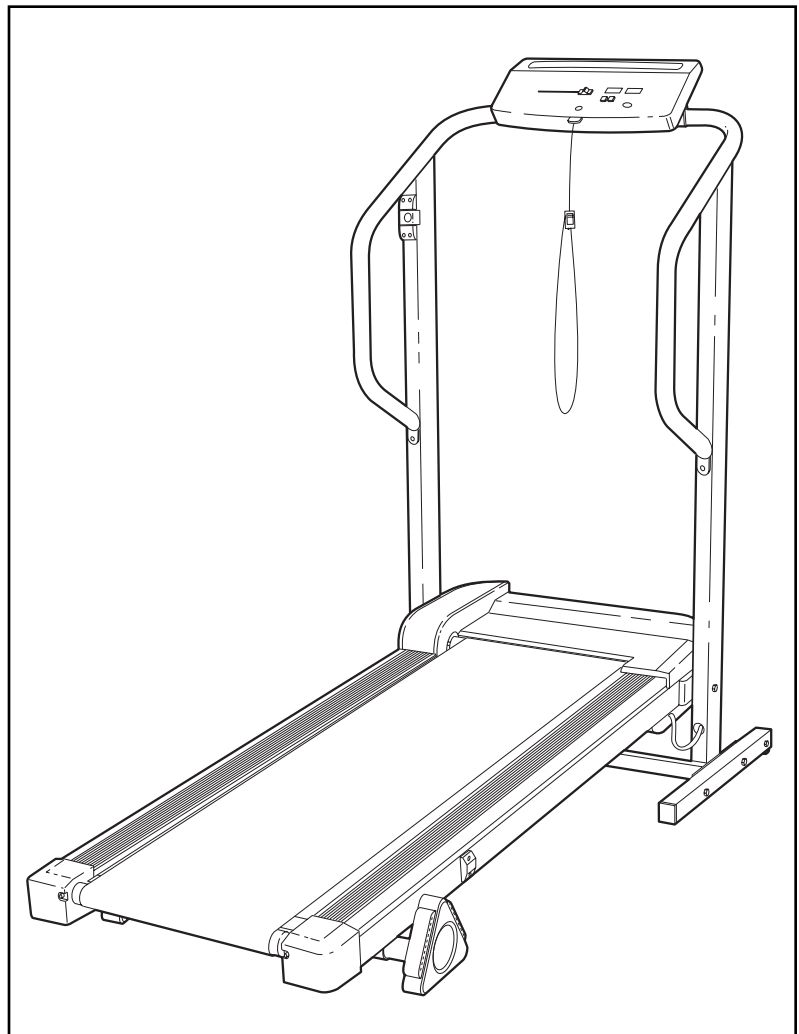

## CAUTION

Read all precautions and instructions in this manual before using this equipment. Save this manual for future reference.

# USER'S MANUAL

# TABLE OF CONTENTS

IMPORTANT PRECAUTIONS .....	2
BEFORE YOU BEGIN .....	4
ASSEMBLY .....	5
OPERATION AND ADJUSTMENT .....	7
HOW TO FOLD AND MOVE THE TREADMILL .....	10
MAINTENANCE AND TROUBLE-SHOOTING .....	12
CONDITIONING GUIDELINES .....	14
ORDERING REPLACEMENT PARTS .....	Back Cover
LIMITED WARRANTY .....	Back Cover

Note: A PART LIST and an EXPLODED DRAWING are attached in the center of this manual. Remove the PART LIST and EXPLODED DRAWING before beginning assembly.

## IMPORTANT PRECAUTIONS

**⚠ WARNING:** To reduce the risk of burns, fire, electric shock, or injury to persons, read the following important precautions and information before operating the treadmill.

1. It is the responsibility of the owner to ensure that all users of this treadmill are adequately informed of all warnings and precautions.
2. Use the treadmill only as described.
3. Place the treadmill on a level surface, with eight feet of clearance behind it. Do not place the treadmill on a surface that blocks any air openings. To protect the floor or carpet from damage, place a mat under the treadmill.
4. Keep the treadmill indoors, away from moisture and dust. Do not put the treadmill in a garage or covered patio, or near water.
5. Do not operate the treadmill where aerosol products are used or where oxygen is being administered.
6. Keep children under the age of 12 and pets away from the treadmill at all times.
7. The treadmill should not be used by persons weighing more than 250 pounds.
8. Never allow more than one person on the treadmill at a time.
9. Wear appropriate exercise clothing when using the treadmill. Do not wear loose clothing that could become caught in the treadmill. Athletic support clothes are recommended for both men and women. Always wear athletic shoes. Never use the treadmill with bare feet, wearing only stockings, or in sandals.
10. When connecting the power cord (see HOW TO PLUG IN THE POWER CORD on page 7), plug the power cord into a surge protector (not included) and plug the surge protector into a grounded circuit capable of carrying 15 or more amps. No other appliance should be on the same circuit.
11. Use only a UL-listed surge protector, rated at 15 amps, with a 14-gauge cord of five feet or less in length. Do not use an extension cord.
12. Keep the power cord and the surge protector away from heated surfaces.
13. Never move the walking belt while the power is turned off. Do not operate the treadmill if the power cord or plug is damaged, or if the treadmill is not working properly. (See BEFORE YOU BEGIN on page 4 if the treadmill is not working properly.)
14. Never start the treadmill while you are standing on the walking belt. Always hold the handrails while using the treadmill.

15. The treadmill is capable of high speeds. Adjust the speed in small increments to avoid sudden jumps in speed.
16. The pulse sensor is not a medical device. Various factors, including the user's movement, may affect the accuracy of heart rate readings. The pulse sensor is intended only as an exercise aid in determining heart rate trends in general.
17. Never leave the treadmill unattended while it is running. Always remove the key and unplug the power cord when the treadmill is not in use.
18. Do not attempt to raise, lower, or move the treadmill until it is properly assembled. (See ASSEMBLY on page 5, and HOW TO MOVE THE TREADMILL on page 10.) You must be able to safely lift 45 pounds (20 kg) in order to raise, lower, or move the treadmill.
19. Do not change the incline of the treadmill by placing objects under the treadmill.

20. When folding or moving the treadmill, make sure that the storage latch is fully closed.
21. Inspect and tighten all parts of the treadmill regularly.
22. Never drop or insert any object into any opening.
23. **DANGER:** Always unplug the power cord immediately after use, before cleaning the treadmill, and before performing the maintenance and adjustment procedures described in this manual. Never remove the motor hood unless instructed to do so by an authorized service representative. Servicing other than the procedures in this manual should be performed by an authorized service representative only.
24. This treadmill is intended for in-home use only. Do not use this treadmill in any commercial, rental, or institutional setting.

**⚠ WARNING:** Before beginning this or any exercise program, consult your physician. This is especially important for persons over the age of 35 or persons with pre-existing health problems. Read all instructions before using. ICON assumes no responsibility for personal injury or property damage sustained by or through the use of this product.

## SAVE THESE INSTRUCTIONS

The decal shown at the right has been placed on your treadmill. If the decal is missing, or if it is not legible, please call our Customer Service Department, toll-free, to order a free replacement decal (see ORDERING REPLACEMENT PARTS on the back cover of this manual). Apply the decal in the location shown.

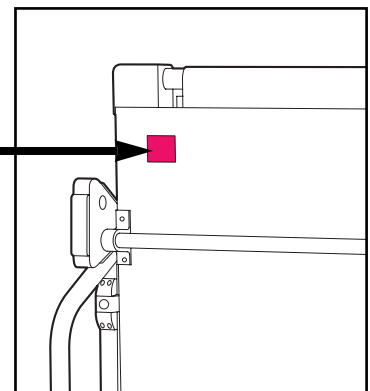

# BEFORE YOU BEGIN

Thank you for selecting the WESLO® CADENCE DX8 treadmill. The CADENCE DX8 combines advanced technology with innovative design to let you enjoy an excellent form of cardiovascular exercise in the convenience and privacy of your home. And when you're not exercising, the CADENCE DX8 can be folded up, requiring less than half the floor space of other treadmills.

**For your benefit, read this manual carefully before using the treadmill.** If you have additional questions, please call our Customer Service Department toll-free

at 1-800-999-3756, Monday through Friday, 6 a.m. until 6 p.m. Mountain Time (excluding holidays). To help us assist you, please note the product model number and serial number before calling. The model number of the treadmill is WTL46090. The serial number can be found on a decal attached to the treadmill (see the front cover of this manual for the location).

Before reading further, please familiarize yourself with the parts that are labeled in the drawing below.

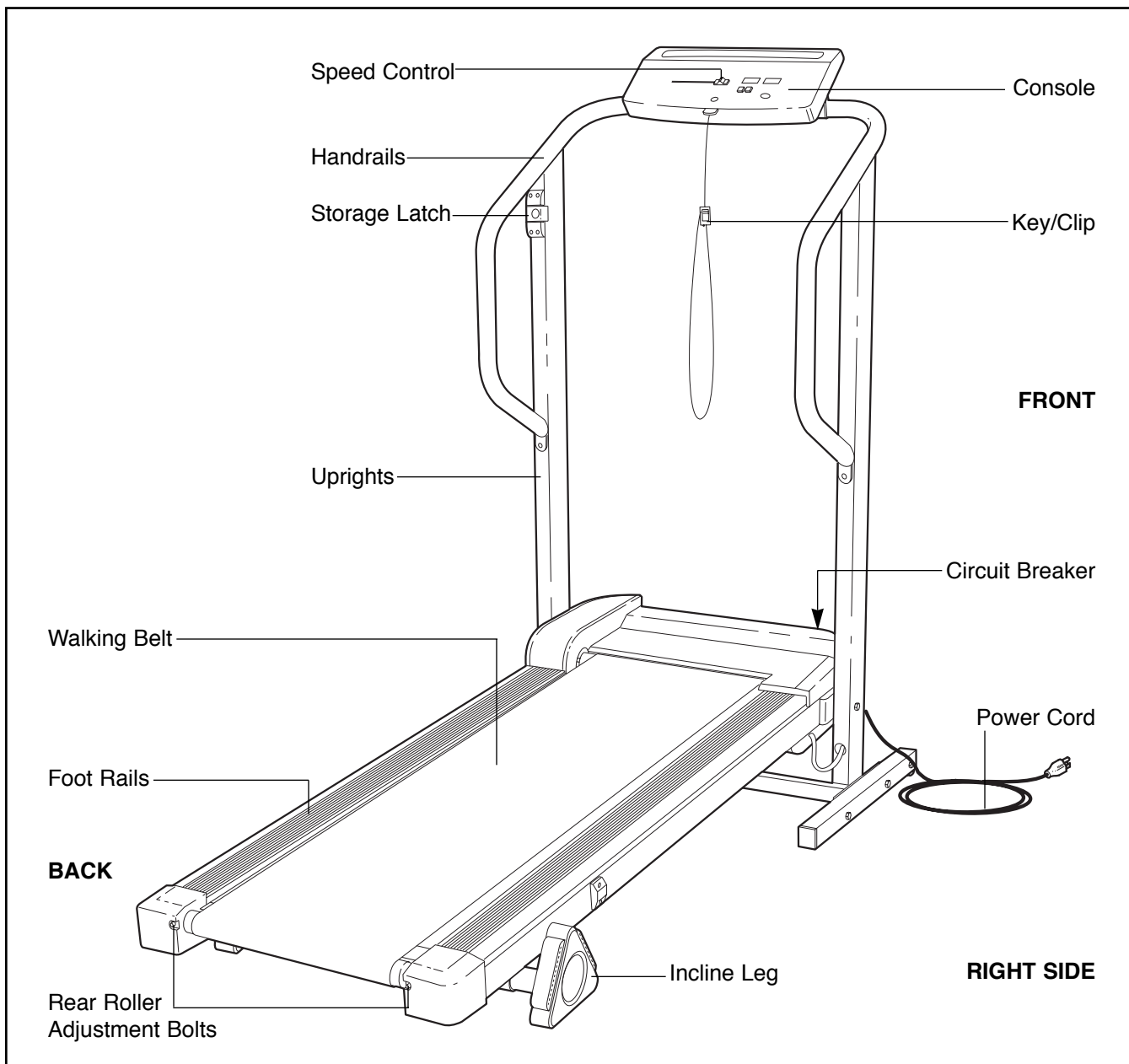

# ASSEMBLY

**Assembly requires two people.** Place all parts in a cleared area and remove the packing materials; do not dispose of the packing materials until assembly is completed.

The following tools (not included) are required for assembly: an adjustable wrench  and a phillips screwdriver .

1. With the help of a second person, carefully raise the Uprights (1) so that both Base Legs (77) are resting flat on the floor as shown.

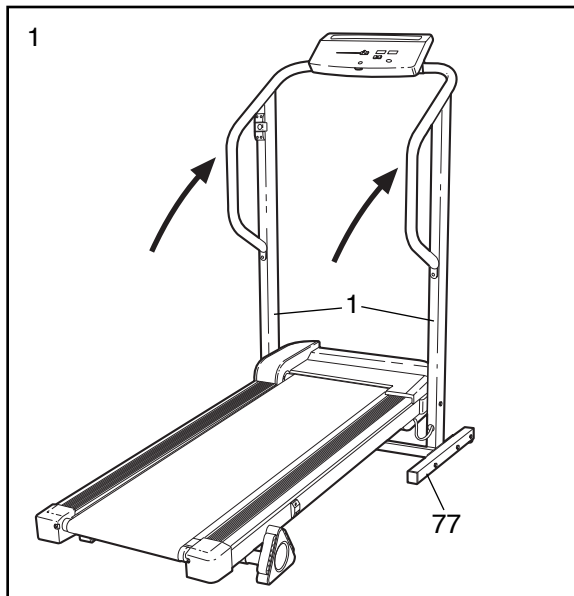

2. Pivot the Console (15) to the position shown and tighten the two Console Bolts (8).

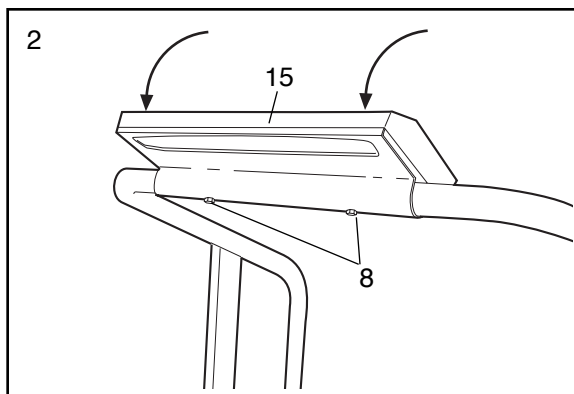

3. The Console (15) requires two "AA" batteries (not included). Alkaline batteries are recommended. Slide the Battery Cover (14) upward and remove it. Insert two "AA" batteries into the Console, making sure that the negative ends of the batteries (marked "-") are touching the springs in the Console. Reattach the Battery Cover.

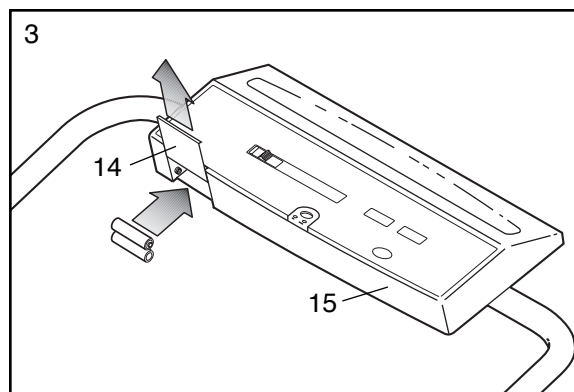

4. Attach the the Latch Catch (70) to the left side of the Frame (95) with four Screws (32). **Make sure that the Latch Catch is turned as shown.** Note: It may be necessary to remove the Latch Catch Screws from the left side of the Frame before beginning this step.

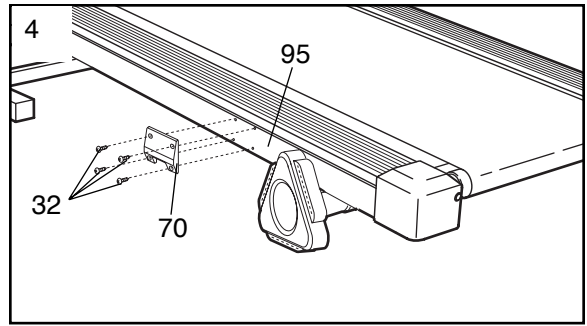

5. Remove the backing from the Adhesive Clip (60). Press the Adhesive Clip onto the base of the Upright (1) in the indicated location. Press the Allen Wrench (61) into the Adhesive Clip.

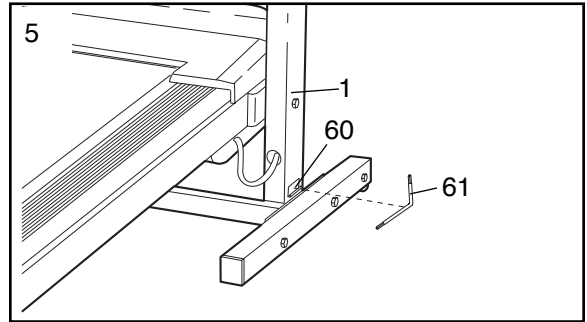

6. **Make sure that all parts are tightened before you use the treadmill.** To protect the floor or carpet, place a mat under the treadmill.

# OPERATION AND ADJUSTMENT

## THE PERFORMANT LUBE™ WALKING BELT

Your treadmill features a walking belt coated with PERFORMANT LUBE™, a high-performance lubricant. **IMPORTANT: Never apply silicone spray or other substances to the walking belt or the walking platform. They will deteriorate the walking belt and cause excessive wear.**

**⚠ DANGER:** Improper connection of the equipment-grounding conductor can result in an increased risk of electric shock. Check with a qualified electrician or serviceman if you are in doubt as to whether the product is properly grounded. Do not modify the plug provided with the product—if it will not fit the outlet, have a proper outlet installed by a qualified electrician.

## HOW TO PLUG IN THE POWER CORD

Your treadmill, like any other type of sophisticated electronic equipment, can be seriously damaged by sudden voltage changes in your home's power. Voltage surges, spikes, and noise interference can result from weather conditions or from other appliances being turned on or off. **To decrease the possibility of your treadmill being damaged, always use a surge protector (not included) with your treadmill.**

Surge protectors are sold at most hardware stores and department stores. Use only a UL-listed surge protector, rated at 15 amps, with a 14-gauge cord of five feet or less in length.

**This product must be grounded.** If it should malfunction or break down, grounding provides a path of least resistance for electric current to reduce the

risk of electric shock. This product is equipped with a cord having an equipment-grounding conductor and a grounding plug. **Plug the power cord into a surge protector, and plug the surge protector into an appropriate outlet that is properly installed and grounded in accordance with all local codes and ordinances.**

This product is for use on a nominal 120-volt circuit, and has a grounding plug that looks like the plug illustrated in drawing 1 below. A temporary adapter that looks like the adapter illustrated in drawing 2 may be used to connect the surge protector to a 2-pole receptacle as shown in drawing 2 if a properly grounded outlet is not available.

The temporary adapter should be used only until a properly grounded outlet (drawing 1) can be installed by a qualified electrician.

The green-colored rigid ear, lug, or the like extending from the adapter must be connected to a permanent ground such as a properly grounded outlet box cover. Whenever the adapter is used it must be held in place by a metal screw. **Some 2-pole receptacle outlet box covers are not grounded. Contact a qualified electrician to determine if the outlet box cover is grounded before using an adapter.**

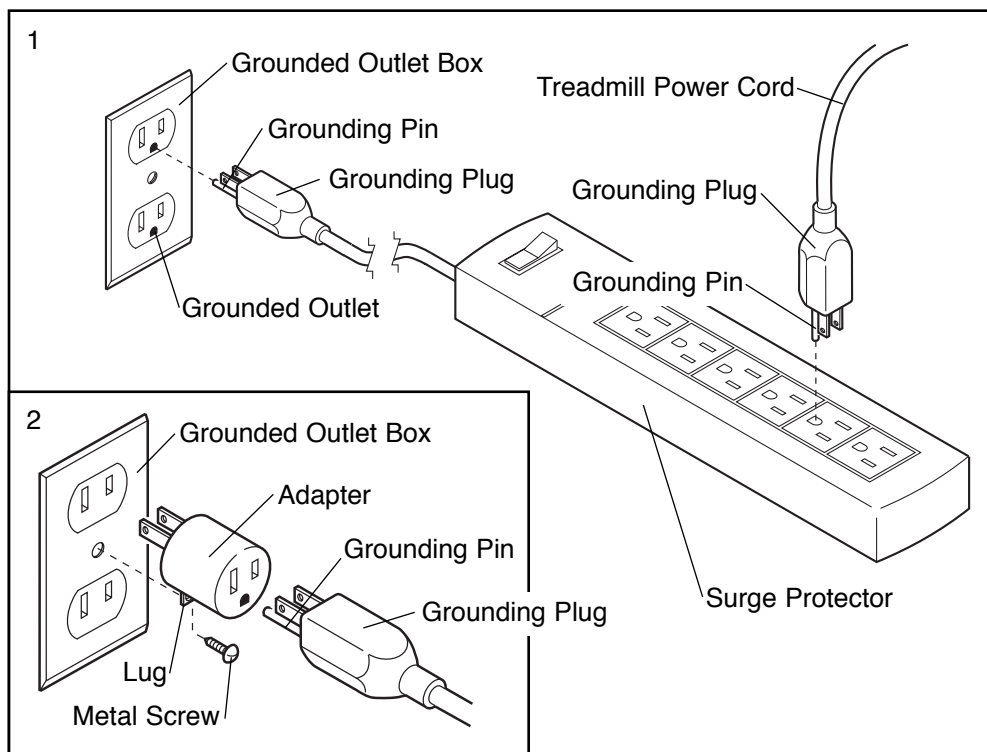



## DIAGRAM OF THE CONSOLE

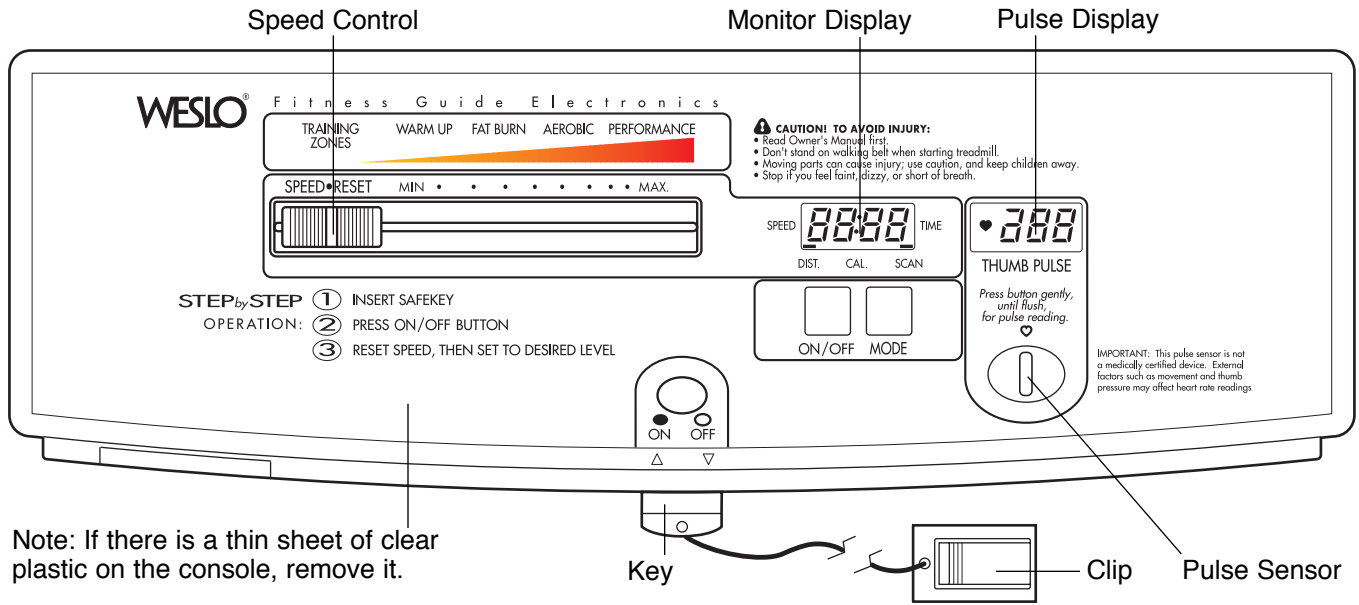

**CAUTION:** Before operating the console, read the following important precautions.

- Do not stand on the walking belt when turning on the power.
- Always wear the clip while operating the treadmill. When the key is removed from the console, the power will shut off.
- After the speed control is moved, there will be a pause before the walking belt begins to move.
- Adjust the speed in small increments until you are familiar with the treadmill.
- The training zones marked above the speed control are guidelines only.
- To reduce the risk of electric shock, keep the console dry. Avoid spilling liquid on the console and use only a sealed water bottle.

### STEP BY STEP CONSOLE OPERATION

Make sure that batteries are installed in the console. (See assembly step 4 on page 6.) Next, make sure that the power cord is properly plugged in. (See HOW TO PLUG IN THE POWER CORD on page 7). Step onto the foot rails of the treadmill. Find the clip attached to the key (see the drawing above), and slide the clip onto your waistband. Follow the steps on pages 8 and 9 to operate the console.

#### 1 Insert the key fully into the power switch.

Note: The two displays will not appear when the key is first inserted.

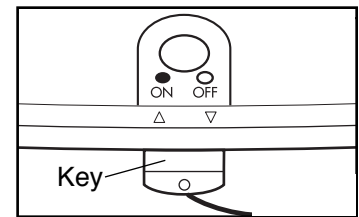

#### 2 Press the ON/OFF button.

The two displays will appear. Note: If batteries were just installed, the displays will already appear.

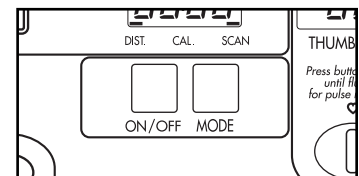

#### 3 Reset the speed control and start the walking belt.

Slide the speed control all of the way to the left, to the "SPEED RESET" position. Next, slide the control to the right until the walking belt begins to move at slow speed. Carefully step onto the walking belt and begin walking. Change the speed of the walking belt as desired by sliding the speed control. Note: To stop the walking belt, slide the speed control to the "SPEED RESET" position.

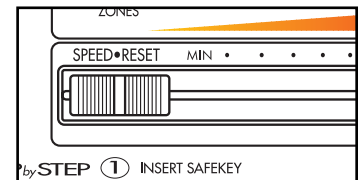



#### 4 Press the MODE button to select the desired monitor mode.

The monitor offers five different modes to provide instant exercise feedback:

- SPEED—displays your speed, in miles per hour.
- TIME—displays the elapsed time.
- DISTANCE—displays the distance that you have walked or run, in miles.
- CALORIES—displays the approximate number of Calories you have burned. Note: The actual number of Calories you have burned may differ slightly from the number displayed if the speed or incline is near the lowest or highest setting.
- SCAN—displays the SPEED, TIME, DISTANCE, and CALORIES modes, for five seconds each, in a repeating cycle.

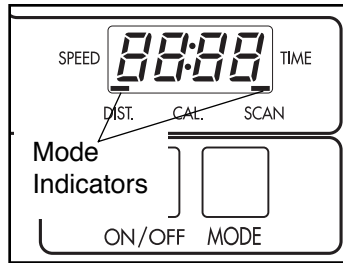

When the power is turned on, the SCAN mode will automatically be selected. One mode indicator (see the drawing above), will appear by the word SCAN, and a second mode indicator will show which mode is currently displayed.

If desired, the SPEED, TIME, DISTANCE or CALORIES mode can be displayed continuously. Press the MODE button repeatedly until the mode indicator by the word SCAN disappears, and a mode indicator appears by the name of the desired mode.

Note: The monitor displays can be reset by pressing the ON/OFF button twice.

#### 5 Measure your pulse, if desired.

To use the pulse sensor, stand on the foot rails and place your thumb on the pulse sensor as shown. The pulse sensor is pressure-activated—fully press it down. **Do not press too hard, or the circulation in your thumb will be restricted, and your pulse will not be detected.** Next, slightly raise your thumb until the heart-shaped indicator in the

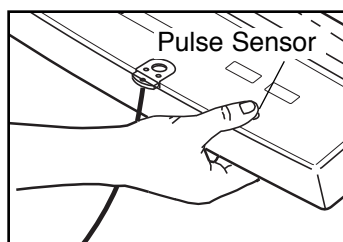

pulse display flashes **steadily**. Hold your thumb at this level. After 5 to 10 seconds, your pulse will be displayed. Hold your thumb on the sensor for another 15 seconds for the most accurate reading.

If the displayed pulse appears to be too high or too low, or if your pulse is not displayed, lift your thumb off the sensor and allow the display to reset. Press down again on the sensor as described above. Make sure that your thumb is positioned as shown, and that you are applying the proper amount of pressure. Try the sensor several times until you become familiar with it. Always stand still while measuring your pulse.

#### 6 When you are finished, stop the walking belt and remove the key.

Step onto the foot rails, slide the speed control to the “SPEED RESET” position, and remove the key. Store the key in a secure location.

#### 7 Press the ON/OFF button.

To turn off the displays, press the ON/OFF button. Note: If the walking belt is stopped and the console buttons are not pressed for 3 to 6 minutes, the displays will turn off automatically.

#### HOW TO CHANGE THE INCLINE OF THE TREADMILL

To vary the intensity of your exercise, the incline of the treadmill can be changed. There are three different incline levels. **Before changing the incline, remove the key and unplug the power cord.**

To change the incline of the treadmill, first hold the rear roller endcap with one hand and raise the back of the treadmill a few inches. Using your other hand, rotate the incline leg to one of the three incline positions. The inset drawing at the right shows the incline leg rotated to the “max fat burn” position. Lower the treadmill, making sure that the incline leg is resting flat on the floor.

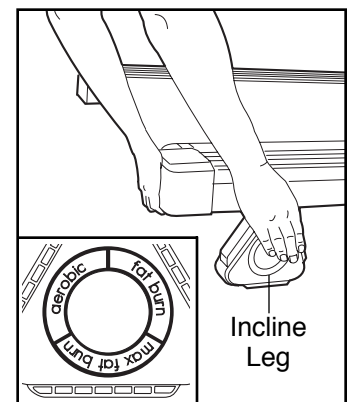

# HOW TO FOLD AND MOVE THE TREADMILL

## HOW TO FOLD THE TREADMILL FOR STORAGE

Before folding the treadmill, unplug the power cord.

**Caution: You must be able to safely lift 45 pounds (20 kg) in order to raise, lower or move the treadmill.**

1. Hold the treadmill with your hands in the locations shown at the right. **To decrease the possibility of injury, bend your legs and keep your back straight. As you raise the treadmill, make sure to lift with your legs rather than your back.** Raise the treadmill about halfway to the vertical position.

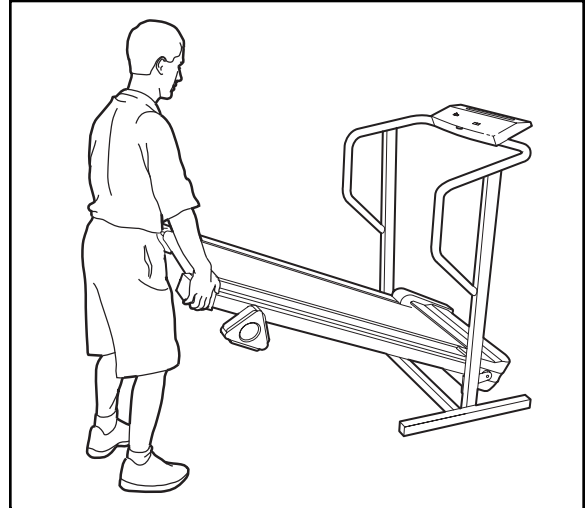

2. Move your right hand to the position shown at the right, and hold the treadmill firmly. Raise the treadmill until the storage latch locks over the latch catch. If necessary, turn the Incline leg as you raise the treadmill. **Make sure that the storage latch closes fully over the latch catch.**

**To protect the floor or carpet from damage, place a mat under the treadmill. Keep the treadmill out of direct sunlight. Do not leave the treadmill in the storage position in temperatures above 85° Fahrenheit.**

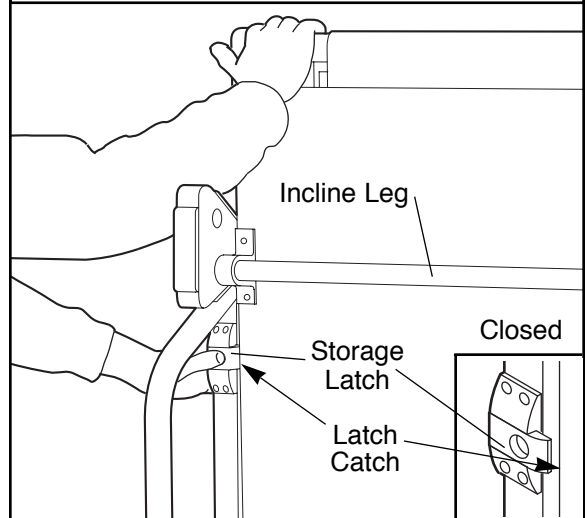

## HOW TO MOVE THE TREADMILL

Before moving the treadmill, convert the treadmill to the storage position as described above. **Make sure that the storage latch is locked fully over the latch catch.**

1. Hold the upper ends of the handrails. Place one foot on one of the front wheels as shown.
2. Tilt the treadmill back until it rolls freely on the front wheels. Carefully move the treadmill to the desired location. **To reduce the risk of injury, use extreme caution while moving the treadmill. Do not attempt to move the treadmill over an uneven surface.**
3. Place one foot on the base, and carefully lower the treadmill until it is resting in the storage position.

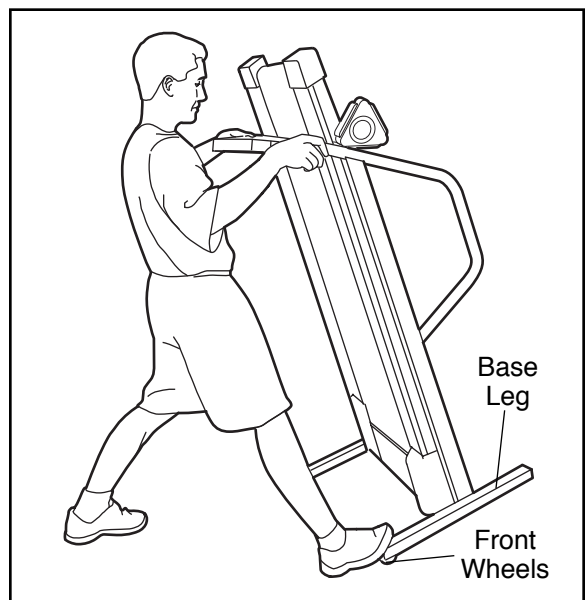

## HOW TO LOWER THE TREADMILL FOR USE

1. Hold the upper end of the treadmill with your right hand as shown. Using your left hand, slide open the storage latch. Pivot the treadmill until the latch catch and the foot rail are past the storage latch. If necessary, turn the Incline leg as you lower the treadmill.

2. Hold the treadmill firmly with both hands, and lower the treadmill to the floor. **To decrease the possibility of injury, bend your legs and keep your back straight.**

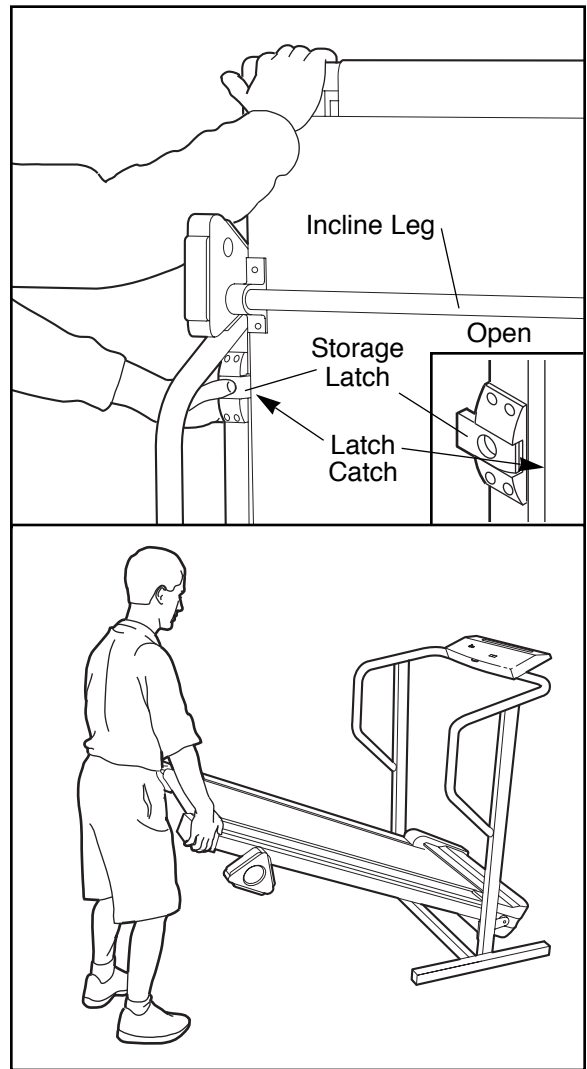

---

# MAINTENANCE AND TROUBLE-SHOOTING

Most treadmill problems can be solved by following the steps below. Find the symptom that applies, and follow the steps listed. If further assistance is needed, please call our Customer Service Department toll-free at 1-800-999-3756, Monday through Friday, 6 a.m. until 6 p.m. Mountain Time (excluding holidays).

**PROBLEM: The power does not turn on**

**SOLUTION:** a. Make sure that the power cord is plugged into a surge protector, and that the surge protector is plugged into a properly grounded outlet. (See HOW TO PLUG IN THE POWER CORD on page 7.) Use only a UL-listed surge protector, rated at 15 amps, with a 14-gauge cord of five feet or less in length.

b. After the power cord has been plugged in, make sure that the key is fully inserted into the console. See step 1 on page 8.

c. Check the circuit breaker located on the treadmill frame near the power cord. If the switch protrudes as shown, the circuit breaker has tripped. To reset the circuit breaker, wait for five minutes and then press the switch back in.

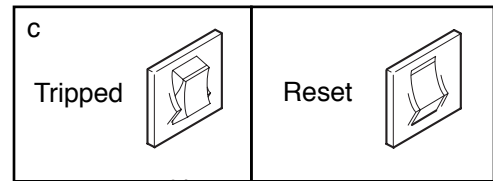

**PROBLEM: The power turns off during use**

**SOLUTION:** a. Check the circuit breaker located on the treadmill frame near the power cord (see the drawing above). If the circuit breaker has tripped, wait for five minutes and then press the switch back in.

b. Make sure that the power cord is plugged in.

c. Remove the key from the console. Reinsert the key fully into the console. See step 1 on page 8.

d. If the treadmill still will not run, please call our Customer Service Department, toll-free.

**PROBLEM: The displays of the console do not function properly**

**SOLUTION:** a. Check the batteries in the console. If the batteries need to be replaced, see assembly step 4 on page 6. Most problems are the result of drained batteries.

b. If the speed display does not show a correct reading, remove the key and **UNPLUG THE POWER CORD**. Remove the screws from the sides and front of the hood. Carefully remove the hood. Locate the Reed Switch (88) and the Magnet (49) on the left side of the Pulley (50). Turn the Pulley until the Magnet is aligned with the Reed Switch. **Make sure that the gap between the Magnet and the Reed Switch is about 1/8"**. If necessary, loosen the Screw (32) and move the Reed Switch slightly. Retighten the Screw. Re-attach the hood and run the treadmill for a few minutes to check for a correct speed reading.

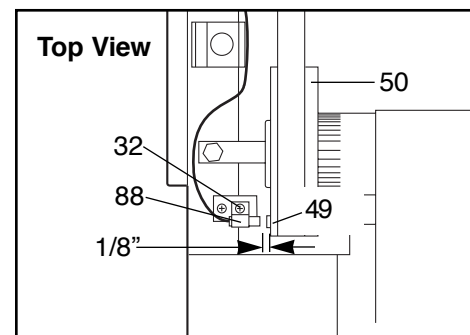

**PROBLEM: The walking belt is off-center or slips when walked on**

**SOLUTION:** a. **If the walking belt has shifted to the left**, first remove the key and **UNPLUG THE POWER CORD**. Using the allen wrench, turn the left rear roller adjustment bolt clockwise, and the right bolt counterclockwise, 1/4 of a turn each. Be careful not to overtighten the walking belt. Plug in the power cord, insert the key and run the treadmill for a few minutes. Repeat until the walking belt is centered.

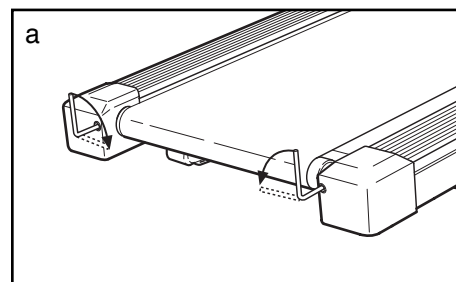

b. **If the walking belt has shifted to the right**, first remove the key and **UNPLUG THE POWER CORD**. Using the allen wrench, turn the left rear roller adjustment bolt counterclockwise, and the right bolt clockwise, 1/4 of a turn each. Be careful not to overtighten the walking belt. Plug in the power cord, insert the key and run the treadmill for a few minutes. Repeat until the walking belt is centered.

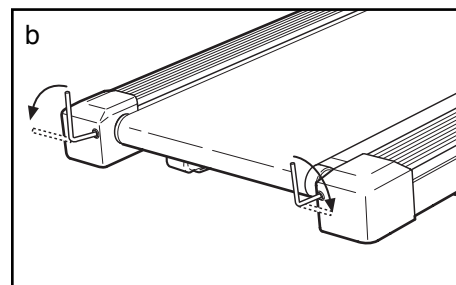

c. **If the walking belt slips when walked on**, first remove the key and **UNPLUG THE POWER CORD**. Using the allen wrench, turn both rear roller adjustment bolts clockwise, 1/4 of a turn. When the walking belt is correctly tightened, you should be able to lift each side of the walking belt 2 to 3 inches off the walking platform. Be careful to keep the walking belt centered. Plug in the power cord, insert the key and run the treadmill for a few minutes. Repeat until the walking belt is properly tightened.

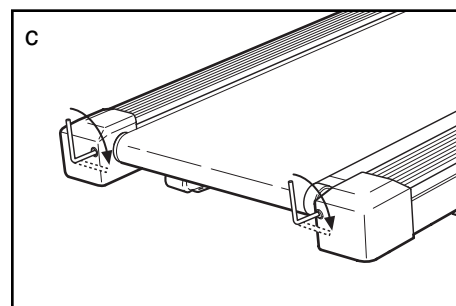

**PROBLEM: The walking belt slows when walked on**

**SOLUTION:** a. Use only a UL-listed surge protector, rated at 15 amps, with a 14-gauge cord of five feet or less in length.

b. If the walking belt is overtightened, treadmill performance may decrease and the walking belt may be permanently damaged. Remove the key and **UNPLUG THE POWER CORD**. Using the allen wrench, turn both rear roller adjustment bolts counterclockwise, 1/4 of a turn. When the walking belt is properly tightened, you should be able to lift each side of the walking belt 2 to 3 inches off the walking platform. Be careful to keep the walking belt centered. Plug in the power cord, insert the key and run the treadmill for a few minutes. Repeat until the walking belt is properly tightened.

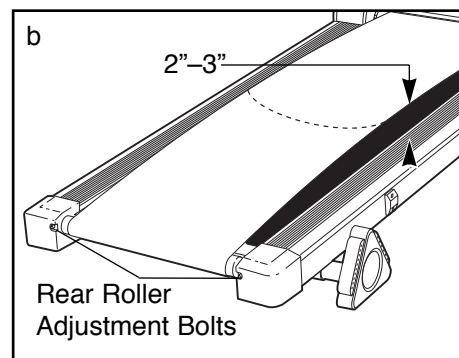

c. If the walking belt still slows when walked on, please call our toll-free Customer Service Department.

# CONDITIONING GUIDELINES

**⚠ WARNING:** Before beginning this or any exercise program, consult your physician. This is especially important for individuals over the age of 35 or individuals with pre-existing health problems.

The pulse sensor is not a medical device. Various factors, including the user's movement, may affect the accuracy of heart rate readings. The pulse sensor is intended only as an exercise aid in determining heart rate trends in general.

## EXERCISE INTENSITY

Whether your goal is to burn fat or to strengthen your cardiovascular system, the key to achieving the desired results is to exercise with the proper intensity. The proper intensity level can be found by using your heart rate as a guide. The chart below shows recommended heart rates for fat burning and aerobic exercise.

AGE	MIN BPM		MAX BPM
	Fat Burn	Max Burn	Aerobic
20	125	145	165
30	120	138	155
40	115	130	145
50	110	125	140
60	105	118	130
70	95	110	125
80	90	103	115

To find the proper heart rate for you, first find your age on the left side of the chart (ages are rounded off to the nearest ten years). Next, find the three numbers to the right of your age. The three numbers are your “training zone.” The lower two numbers are recommended heart rates for fat burning; the higher number is the recommended heart rate for aerobic exercise.

### Fat Burning

To burn fat effectively, you must exercise at a relatively low intensity level for a sustained period of time. During the first few minutes of exercise, your body

uses easily accessible carbohydrate calories for energy. Only after the first few minutes does your body begin to use stored fat calories for energy. If your goal is to burn fat, adjust the speed and incline of the treadmill until your heart rate is near one of the lower two numbers in your training zone.

### Aerobic Exercise

If your goal is to strengthen your cardiovascular system, your exercise must be “aerobic.” Aerobic exercise is activity that requires large amounts of oxygen for prolonged periods of time. This increases the demand on the heart to pump blood to the muscles, and on the lungs to oxygenate the blood. For aerobic exercise, adjust the speed and incline of the treadmill until your heart rate is near the highest number in your training zone.

## WORKOUT GUIDELINES

Each workout should include the following three important parts:

**A warm-up**—Start each workout with 5 to 8 minutes of stretching and light exercise (see SUGGESTED STRETCHES on page 15). A proper warm-up increases your body temperature, heart rate, and circulation in preparation for exercise.

**Training zone exercise**—After warming up, increase the intensity of your exercise until your heart rate is in your training zone for 20 to 60 minutes. (During the first few weeks of your exercise program, do not keep your heart rate in your training zone for longer than 20 minutes.) Breathe regularly and deeply as you exercise—do not hold your breath.

**A cool-down**—Finish each workout with 5 to 8 minutes of stretching to cool down. This will increase the flexibility of your muscles and will help to prevent post-exercise problems.

### Exercise Frequency

To maintain or improve your condition, complete three workouts each week, with at least one day of rest between workouts. After a few months, you may complete up to five workouts each week if desired.

The key to success is to make exercise a regular and enjoyable part of your everyday life.



## SUGGESTED STRETCHES

The correct form for several basic stretches is shown in the drawings below. Move slowly as you stretch—never bounce.

### 1. Toe Touch Stretch

Stand with your knees bent slightly and slowly bend forward from your hips. Allow your back and shoulders to relax as you reach down toward your toes as far as possible. Hold for 15 counts, then relax. Repeat 3 times. Stretches: Hamstrings, back of knees and back.

### 2. Hamstring Stretch

Sit with one leg extended. Bring the sole of the opposite foot toward you and rest it against the inner thigh of your extended leg. Reach toward your toes as far as possible. Hold for 15 counts, then relax. Repeat 3 times for both legs. Stretches: Hamstrings, lower back and groin.

### 3. Calf/Achilles Stretch

With one leg in front of the other, reach forward and place your hands against a wall. Keep your back leg straight and your back foot flat on the floor. Bend your front leg, lean forward and move your hips toward the wall. Hold for 15 counts, then relax. Repeat 3 times for both legs. To cause further stretching of the achilles tendons, bend your back leg as well. Stretches: Calves, achilles tendons and ankles.

### 4. Quadriceps Stretch

With one hand against a wall for balance, reach back and grasp one foot with your other hand. Bring your heel as close to your buttocks as possible. Hold for 15 counts, then relax. Repeat 3 times for both legs. Stretches: Quadriceps and hip muscles.

### 5. Inner Thigh Stretch

Sit with the soles of your feet together and your knees outward. Pull your feet toward your groin area as far as possible. Hold for 15 counts, then relax. Repeat 3 times. Stretches: Quadriceps and hip muscles.

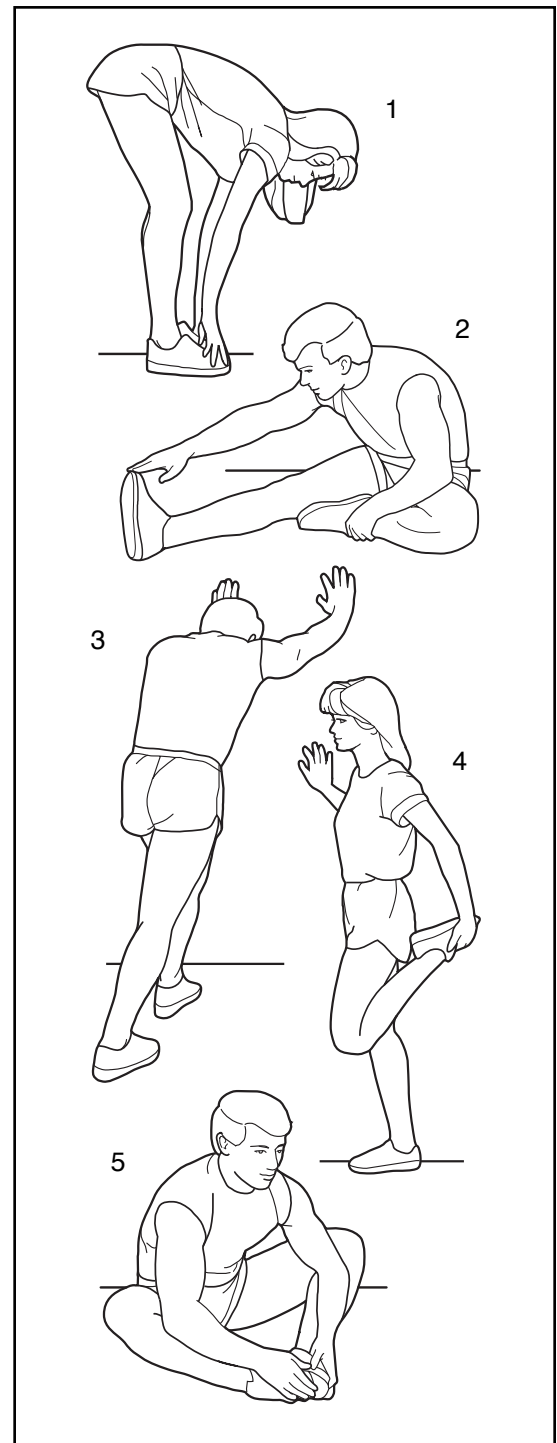



# PART LIST—Model No. WLTL46090

R0299A

Key No.	Qty.	Description	Key No.	Qty.	Description
1	1	Upright	50	1	Front Roller/Pulley
2	4	Washer	51	1	Left Foot Rail
3	4	Handrail Bolt	52	1	Walking Belt
4	1	Storage Latch	53	6	Small Screw
5	10	Latch Screw	54	1	Right Frame Guide
6	4	Cage Nut	55	2	Roller Guard
7	1	Left Handrail	56	2	Incline Leg Plate
8	2	Console Bolt	57	6	Incline Leg Pad
9	4	Console Screw	58	2	Incline Leg Bolt
10	2	Pivot Washer	59	2	Incline Leg
11	1	Console Plate	60	1	Adhesive Clip
12	1	Console Assembly	61	1	Allen Wrench
13	1	Speed Control	62	2	Rear Roller Adjustment Bolt
14	1	Battery Cover	63	1	Right Treadmill Endcap
15	1	Console	64	1	Left Treadmill Endcap
16	1	Right Handrail	65	14	Belly Pan Fastener
17	1	Key/Clip	66	1	Ground Wire
18	1	Choke	67	1	Latch Warning Decal
19	7	Choke Screw	68	1	Treadmill Incline Rod
20	5	Ground/Control Screw	69	1	Rear Roller
21	1	Controller	70	1	Latch Catch
22	1	Motor/Pulley/Flywheel/Fan	71	2	Electronic Bracket
23	1	Motor Bolt	72	1	Rear Belly Pan
24	1	Motor Tension Washer	73	1	Interface Bracket
25	1	Star Washer	74	4	Belt Guide Screw
26	1	Motor Nut	75	2	Belt Guide
27	1	Motor Pivot Bolt	76	1	Motor Belly Pan
28	1	Motor	77	2	Base Leg
29	1	Pulley/Flywheel/Fan	78	4	Base Leg Pad
30	1	Motor Belt	79	4	Base Leg Bolt
31	1	Circuit Breaker	80	8	Base Leg Washer
32	16	Screw	81	2	Wheel Bolt
33	4	Hood Anchor	82	2	Base Leg Endcap
34	1	Front Roller Adjustment Bolt	83	2	Frame Pivot Bolt
35	1	Releasable Cable Tie	84	2	Wheel
36	2	Front Roller Bolt	85	6	Base Leg Nut
37	2	Frame Pivot Spacer	86	1	Wire Harness
38	1	Reed Switch Bracket	87	1	Grommet
39	1	Motor Hood	88	1	Reed Switch
40	1	Clamp Screw	89	1	Wire Clip
41	1	Tie Clamp	90	1	Reed Switch Clip
42	3	8" Cable Tie	91	1	Power Cord Grommet
43	1	Right Foot Rail	92	1	Power Cord
44	8	Deck Screw	93	2	Incline Leg Bushing
45	2	Front Roller Nut	94	2	Incline Leg Bracket
46	1	Walking Deck	95	1	Frame
47	2	Treadmill Pivot Nut	#	1	8" White Wire, Male/Female
48	1	Motor Pivot Nut	#	1	User's Manual
49	1	Magnet			

Note: “#” indicates a non-illustrated part. Specifications are subject to change without notice. See the back cover of the user's manual for information about ordering replacement parts.



---

# ORDERING REPLACEMENT PARTS

To order replacement parts, simply call our Customer Service Department toll-free at 1-800-999-3756, Monday through Friday, 6 a.m. until 6 p.m. Mountain Time (excluding holidays). To help us assist you, please be prepared to give the following information when calling:

- The MODEL NUMBER of the product (WLTL46090).
- The NAME of the product (WESLO® CADENCE DX8 treadmill).
- The SERIAL NUMBER of the product (see the front cover of this manual).
- The KEY NUMBER and DESCRIPTION of the desired part(s) (see the PART LIST and the EXPLODED DRAWING in the center of this manual).

WESLO is a registered trademark of ICON Health & Fitness, Inc.

## LIMITED WARRANTY

ICON Health & Fitness, Inc. (ICON), warrants this product to be free from defects in workmanship and material, under normal use and service conditions, for a period of ninety (90) days from the date of purchase. This warranty extends only to the original purchaser. ICON's obligation under this warranty is limited to replacing or repairing, at ICON's option, the product through one of its authorized service centers. All repairs for which warranty claims are made must be pre-authorized by ICON. This warranty does not extend to any product or damage to a product caused by or attributable to freight damage, abuse, misuse, improper or abnormal usage or repairs not provided by an ICON authorized service center, products used for commercial or rental purposes, or products used as store display models. No other warranty beyond that specifically set forth above is authorized by ICON.

ICON is not responsible or liable for indirect, special or consequential damages arising out of or in connection with the use or performance of the product or damages with respect to any economic loss, loss of property, loss of revenues or profits, loss of enjoyment or use, costs of removal, installation or other consequential damages of whatsoever nature. Some states do not allow the exclusion or limitation of incidental or consequential damages. Accordingly, the above limitation may not apply to you.

The warranty extended hereunder is in lieu of any and all other warranties and any implied warranties of merchantability or fitness for a particular purpose is limited in its scope and duration to the terms set forth herein. Some states do not allow limitations on how long an implied warranty lasts. Accordingly, the above limitation may not apply to you.

This warranty gives you specific legal rights. You may also have other rights which vary from state to state.

**ICON HEALTH & FITNESS, INC., 1500 S. 1000 W., LOGAN, UT 84321-9813**