

STAR BY UNISEN, INC.

TRAC 1400

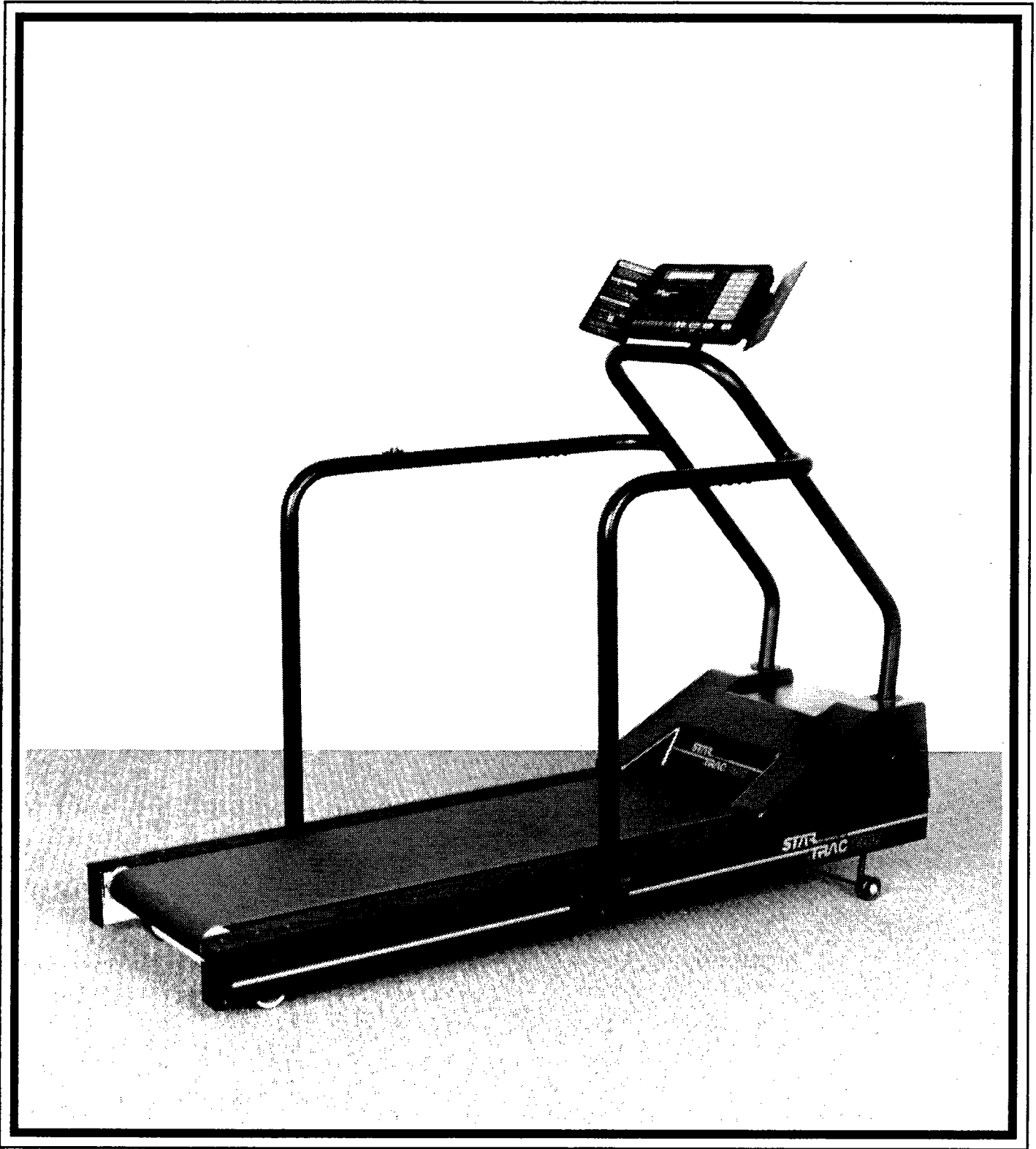

620-0102

B:16K09

STAR BY UNISEN, INC.

TRAC[®]

**STARTRAC 1400, 1500 AND 2000'S
OPERATING AND OWNERS MANUAL**

Warning: Please advise users that the Startrac 2000 (1500/1400) is designed for aerobic exercise. Exercise can cause cardiac stress. Check with a doctor prior to usage. User should not push to excess and should stop if feeling faint, dizzy or exhausted. Common sense must be used when running or walking on machine.



STARTRAC 1400

OPERATING AND OWNER'S MANUAL

| | |
|-------------------------------------|---------|
| INTRODUCTION | PAGE 1 |
| PROGRAM OPERATION | PAGE 1 |
| SAFETY NOTES | PAGE 1 |
| OPERATING MODES | PAGE 2 |
| PRE-SET ELEVATION TERRAINS | PAGE 2 |
| INTERVAL TRAINING (LAPS MODE) | PAGE 12 |
| MANUAL OPERATION | PAGE 14 |
| ADVANCED MANUAL OPERATION | PAGE 15 |
| INDICATORS AND DISPLAYS | PAGE 16 |
| PULSE RATE TIMER | PAGE 16 |
| DIAGNOSTIC TEST MODES | PAGE 17 |
| DISPLAY TEST MODE | PAGE 17 |
| MOTOR TEST MODE | PAGE 17 |
| ERROR MESSAGES | PAGE 18 |
| CPU ERROR | PAGE 18 |
| ELEVATION ERROR | PAGE 18 |
| FAIL-SAFE ERROR | PAGE 19 |
| SPEED ERROR | PAGE 19 |
| BELT ADJUSTMENTS | PAGE 19 |
| RUNNING BELT | PAGE 19 |
| MOTOR BELT | PAGE 19 |
| ELEVATION BELT | PAGE 20 |
| RUNNING BED | PAGE 20 |
| TROUBLE-SHOOTING CHARTS | PAGE 21 |

Model 1400FPD, 16 & 20 km/hr
Serial Number _____

STARTRAC 1400

FEATURES

- Easy to Operate
- Durable and Reliable
- Smooth, Quiet Operation
- Lifetime Structural Frame Warranty
- 8 Pre-Programmed Running Terrains
- 1 - 16 km/hr (20 km/hr Optional) Speed Range with .1 km/hr command resolution
- Manual Operation - select any speed and elevation
- Interval/Laps Program - design your own speed and elevation, up to 5 different intervals.
- Motivational, LED illuminated, oval track of 100 meters pinpoints your progress at all times.

The **ULTIMATE** treadmill lets you discover the fun of running through the mountains, sprinting the 100 meter dash or walking at **YOUR** own pace and comfort.

You can select one of the eight pre-set elevation running terrains, enter your weight to get an accurate calories burned readout and select the time you want to run. Each programmed running terrain (20 minute fixed duration) has a 2 minute warm-up and a 3 minute cool-down period. Push the **[FAST]** key to change your "**HIGH SPEED**" at any time. The **[DISP]** key switches the display from "**TIME / DISTANCE / SPEED**" to "**CALORIES per HOUR / TOTAL CALORIES / PACE (min./kilometer)**" and back.

In the Manual Program **YOU** select your own speed and elevation with just the touch of a few buttons.

The Interval/Laps Program will operate your personally designed running laps (100 meter), up to five different intervals, automatically adjusting speed and elevation.

SPECIFICATIONS

- 44mm x 102mm Heli-Arc welded Uni-Frame
- 432mm x 1372mm Running Area
- 1.5 HP Custom Built DC Drive motor
- Electrical Requirements:
 - 20 Amp dedicated circuit (all models)
 - 16 km/hr Model: 100-120VAC / 200-240VAC *
 - 20 km/hr Model: 110-120VAC / 220-240VAC *
- 2.1m power cord
- Speed Range: 1-16 km/hr (20 km/hr opt.) (.1 km/hr increments, +/-.2 km/hr)
- 0-15% Grade Elevation (1% increments)
- Length: 1854mm
 - Width: 628mm (with side handrails 787mm)
 - Height: 1321mm (0% Grade)
 - 165mm to running surface
 - Weight: 95 kg.

DIGITAL READOUTS AND VISUAL INDICATORS

Elapsed Time
Distance
Speed
Calories per Hour
Total Calories
Pace (min./kilometer)
Pulse Rate Timer
Elevation LED's (% Grade)
Program Selection LED's

One year limited parts warranty.

* Nominal Ratings. Depending on region, the treadmill will be equipped for either 100-120V or 200-240V Lines.

CONGRATULATIONS!

You have just received **STARTRAC 1400** from the designers and manufacturers of the world's first fully programmable, microprocessor controlled, motivational treadmill, specifically designed for your personal exercise programs and continuous pleasure.

STARTRAC 1400, THE ULTIMATE treadmill, with its advanced electronic programs, allows **YOU** to select and control the entire running terrain and exercise conditions. Because of its superior electronic design, the **STARTRAC 1400** can run one of eight **ELEVATION TERRAINS**, or up to five **INTERVAL LAPS**, or can operate **MANUALLY**.

PROGRAM OPERATION

During a *PRE-SET ELEVATION TERRAIN* program, speed and elevation change automatically. Three beeps signal a change. Use **[FAST]**, **[SLOW]**, or the number keys to alter your programmed "**HI SPEED**".

During *Interval Training*, the speed and elevation advance through your programmed values. Three beeps signal the change from one interval to the next. You can set a new speed or elevation for the remainder of the current interval or for the duration of the program.

In *Manual Mode*, the operation of the treadmill is entirely under your control. Selected speed and elevation can be changed at your command.

IMPORTANT SAFETY NOTES

Between each use, the treadmill returns the elevation to 0%. As a safety precaution, the belt will not start moving until this is completed.

DO NOT....ATTEMPT TO USE THE STARTRAC 1400 WITHOUT FIRST READING THIS MANUAL.

Should you have any questions regarding its use and maintenance, contact your dealer or the manufacturer.

DO NOT...use the STARTRAC 1400 without first consulting your doctor.

DO NOT...stand or position your feet under the unit.

DO NOT...allow running in bare or stocking feet.

DO NOT...place in an unsupervised location.

DO NOT...play on or around the equipment.

DO NOT...overtighten the running belt.

OPERATING MODES

After reset, "UNISEN" displays for 3 seconds or until a key is pressed. The treadmill next asks for a choice of program and displays "CHOOSE 0-9". You can:

- A. Select one of eight *PRE-SET ELEVATION TERRAINS* to set up a programmed course, setting speed (maximum specified by user) and elevation automatically. Each terrain features a 2 minute warm-up and a 3 minute cool-down.
- B. Select *INTERVAL TRAINING* to create and run your own terrain profile. Up to five intervals consisting of Speed, Elevation and Distance are entered by the user. Once entered, the profile will be run (and repeated if completed) until the user-specified time limit is reached.
- C. Select *MANUAL OPERATION* to run without automatic speed, elevation or time settings. All speed and elevation changes are made on command.
- D. Select *ADVANCED MANUAL OPERATION* to run without automatic speed or elevation, but with time limits. *ADVANCED MANUAL OPERATION* also allows you to enter your running speed before you start running.

Except for *MANUAL OPERATION*, all modes operate for 20 minutes and request the runner's weight (for Calorie computations). *MANUAL OPERATION* continues until stopped by the runner and assumes the runner's weight to be 70 kilograms.

PRE-SET ELEVATION TERRAINS

The eight *Pre-Set Elevation Terrains* set speed and elevation automatically and are selected and set up as follows:

- When the display reads "**CHOOSE 0-9**", press the number key ([1] through [8]) corresponding to the desired terrain depicted on the display panel. Elevation and speed profiles for each terrain are also detailed on pages 4 through 11, with Program 1 being the easiest and Program 8 the most difficult.
- The display now asks you to enter your weight by displaying "**KILOS =**". Enter your weight (20-199 kg) by pressing the number keys, then press **[ENTER]**.
- Next, enter your maximum speed at the "**HI SPEED =**" prompt, or press **[DISP]** to change the display to read "**HI PACE =**" (Minutes per kilometer). **AS SOON AS THE MAXIMUM SPEED OR PACE IS KEYED IN AND [ENTER] IS PRESSED, THE PROGRAM BEGINS AND THE RUNNING BELT WILL START MOVING.**

Each course begins with a two-minute warm-up, starting at 50% and gradually increasing to your maximum speed, and ends with a three-minute cool-down period of decreasing speed. Each course lasts for 20 minutes, advancing terrain segments every 30 seconds. Each segment advance is signaled with three beeps as speed and elevation are set in accordance to the graphs shown on pages 4 through 11.

The oval track display shows your progress around a 100 meter track, starting from bottom center and moving counter-clockwise. As more ground is covered, the tail end of the “comet” circling the track grows. Halfway through a course, half of the track is lit, and the entire track is lit at the end of a program.

Five beeps signal the end of the program, and the numerical display cycles through “---FINISH---”, your total elapsed time, distance covered, average speed, and your total calories, average calories per hour, and average pace (minutes per kilometer).

While running in *Pre-Set Elevation Terrains*, you can also perform the following functions:

- **STOP / PAUSE** Pressing [**STOP**] once stops the treadmill and “**PAUSES**” operation. You can continue your program by simply pressing the [**START**] key. Pressing [**STOP**] twice (or remaining in “PAUSE” mode over 20 seconds) stops the treadmill, cancels your program, and returns you to the “**CHOOSE 0-9**” display.
- **CHANGE SPEED** Your “**HI SPEED**” or “**HI PACE**” (selectable with the [**DISP**] key) can be set simply by pressing the number keys indicating the desired value and then pressing [**ENTER**]. Speed may also be changed by pressing the [**FAST**] and [**SLOW**] keys which will increase and decrease the speed of the belt as long as they are held down.
NOTE: DURING WARM-UP OR AT ELEVATION ABOVE 0% GRADE, THE CURRENT BELT SPEED IS A PERCENTAGE (50%-97%) OF THE “HI SPEED” AND WILL EVENTUALLY ACCELERATE TO THE “HI SPEED” ENTERED.
- **CHANGE ELEVATION** The [**UP**] and [**DOWN**] arrow keys control elevation by moving an elevation target represented by a blinking indicator in the *PERCENT GRADE* display. The treadmill moves up or down until the elevation matches the target. When used in the *Pre-Set Elevation Terrains*, however, the elevation will return to the programmed settings at the next terrain segment (within 30 seconds).
- **TOGGLE DISPLAY** The [**DISP**] key switches between *Elapsed Time – Distance – Speed* and *Calories per Hour – Total Calories – Pace* on the display. If pressed when you request a speed (km/hr), it changes the display to a **PACE** (minutes per kilometer) mode.
- **PULSE RATE TIMER** The STARTRAC treadmill features a built-in timer which enables you to monitor your pulse rate when the program is paused or finished. Activate the timer by pressing the [**LAPS**] key when the display reads “---PAUSE---” or “---FINISH---”. The timer beeps every 6 seconds. To obtain your heart rate, count pulses between beeps and multiply by 10. The timer can be reset **ANY** time by pressing the [**LAPS**] key.

Startrac Terrain Profile
 Program #1
 Elevation

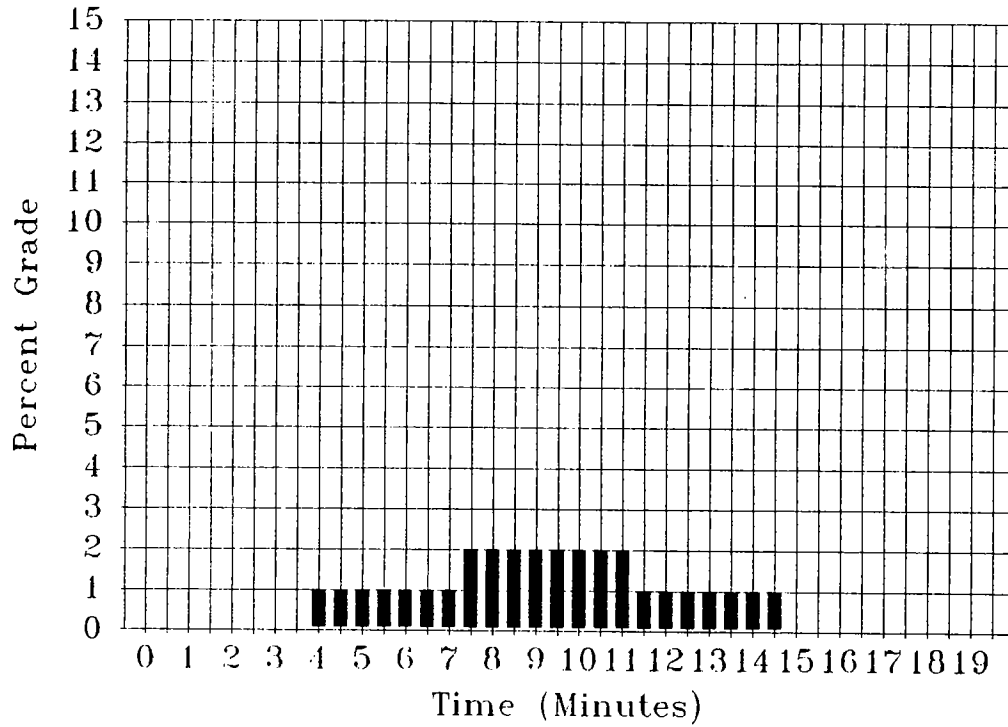

LEGEND
 ■ Elevation
 (Maximum 2%)

Speed

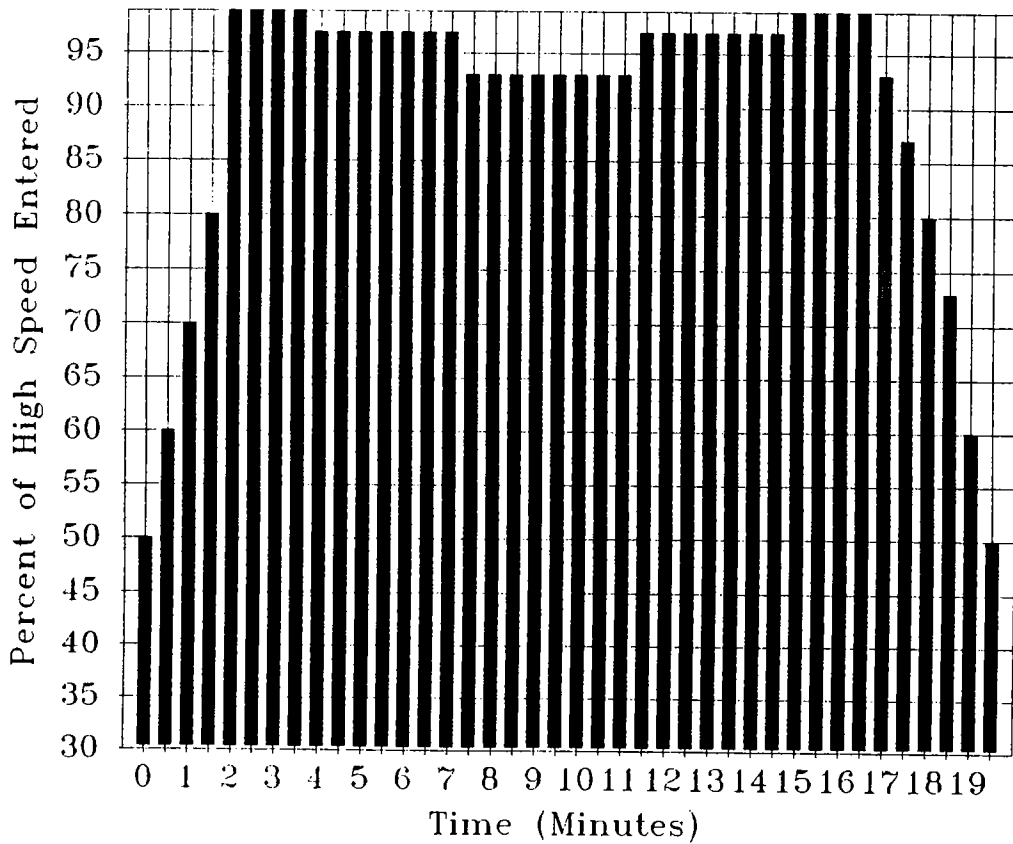

LEGEND
 ■ HiSpeed %

Startrac Terrain Profile
 Program #2
 Elevation

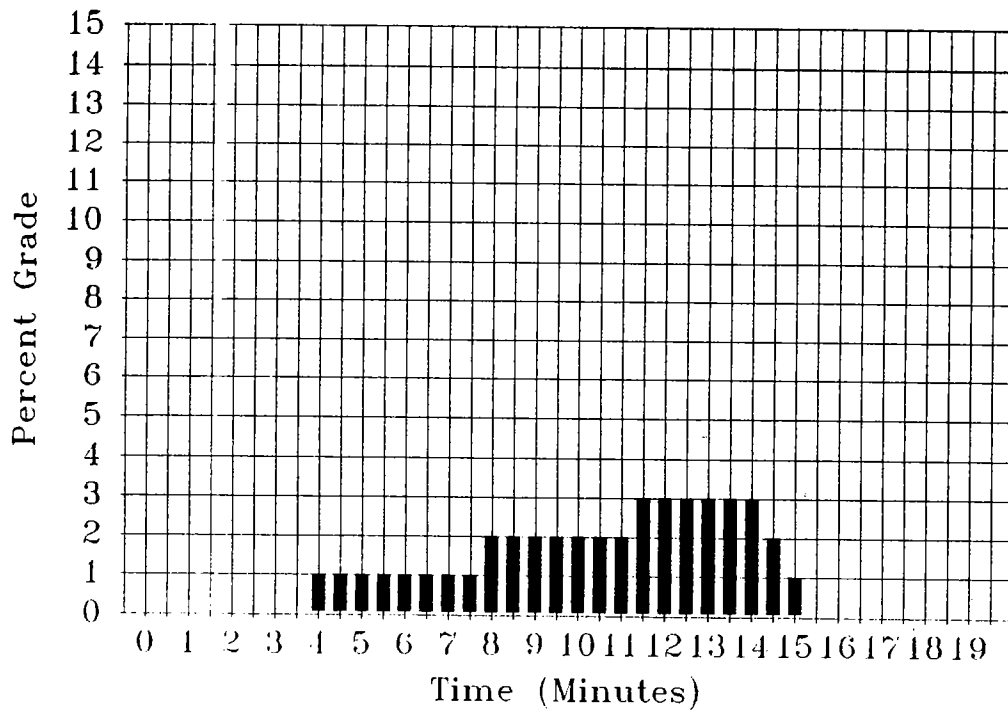

LEGEND
 ■ Elevation
 (Maximum 3%)

Speed

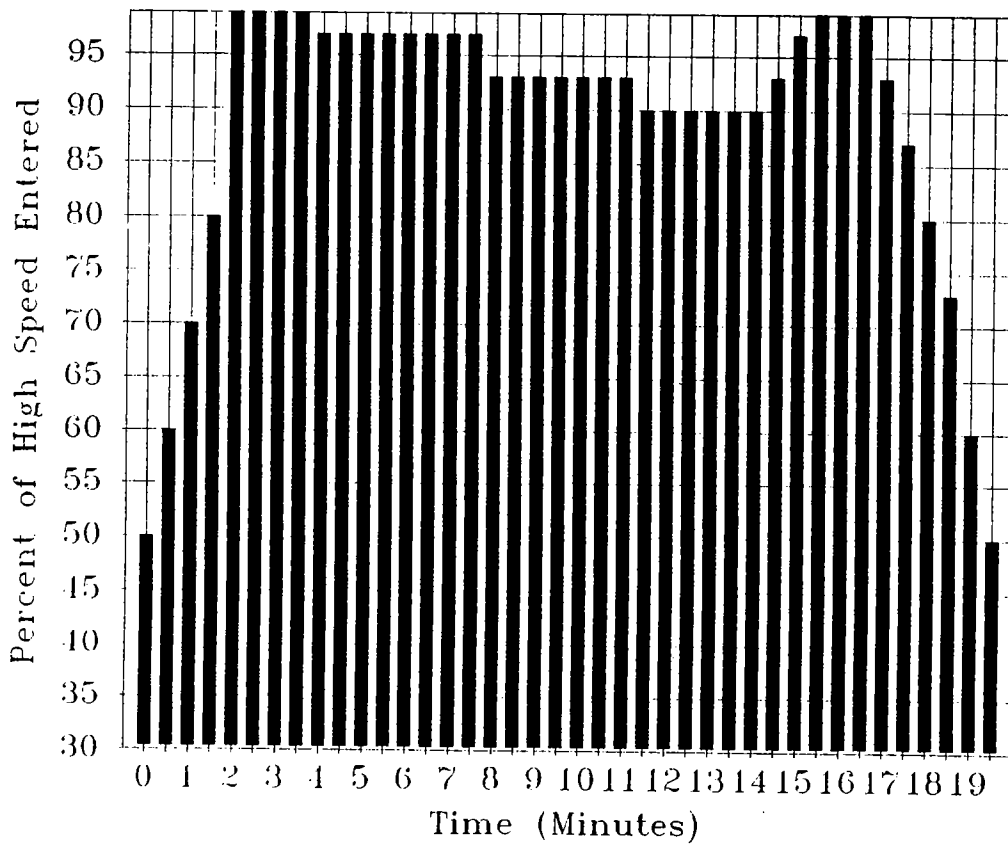

LEGEND
 ■ HiSpeed %

Startrac Terrain Profile
 Program #3
 Elevation

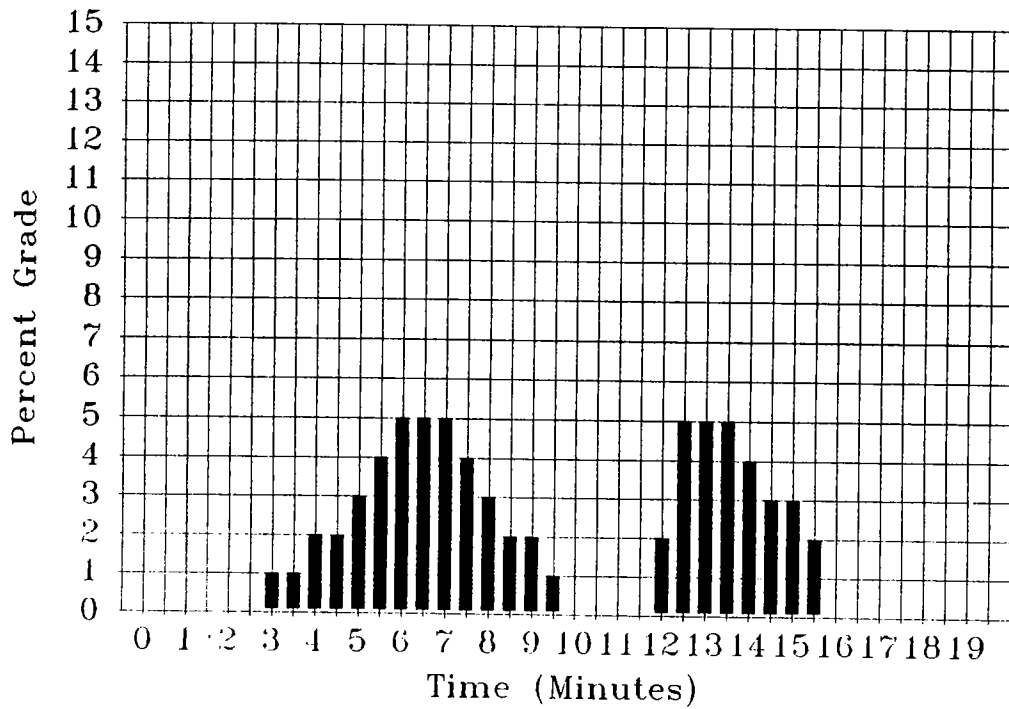

LEGEND
 ■ Elevation
 (Maximum 5%)

Speed

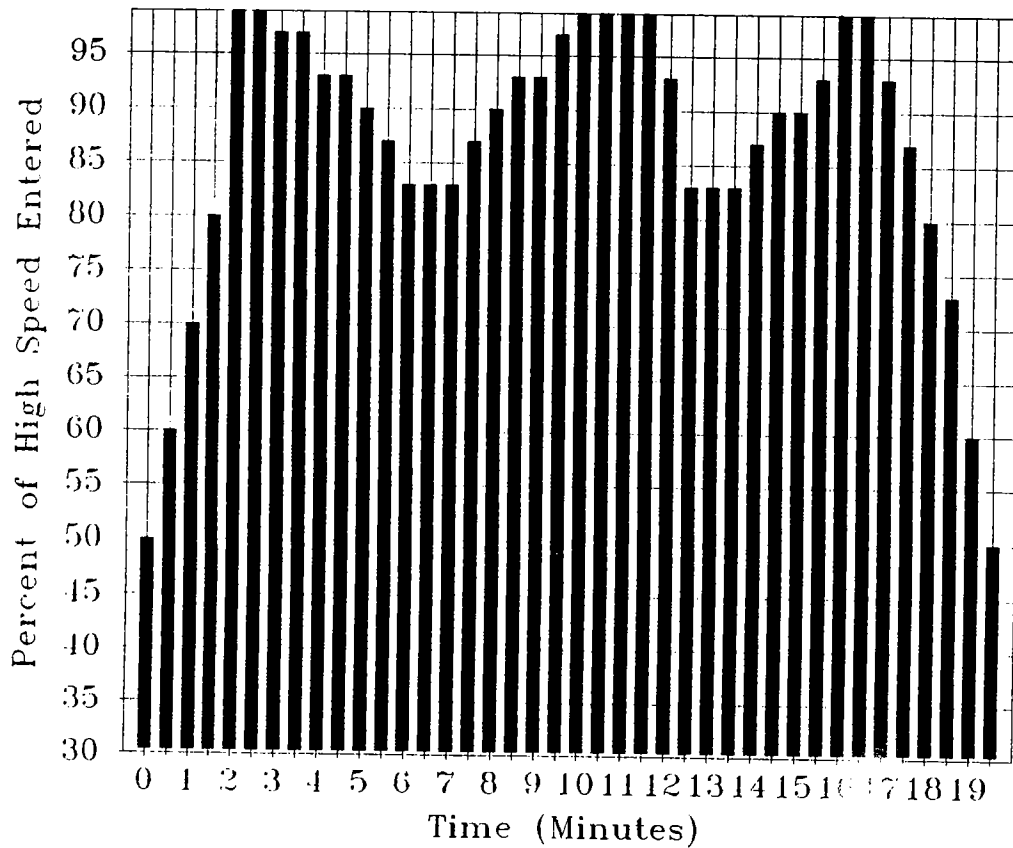

LEGEND
 ■ HiSpeed %

Startrac Terrain Profile
 Program #4
 Elevation

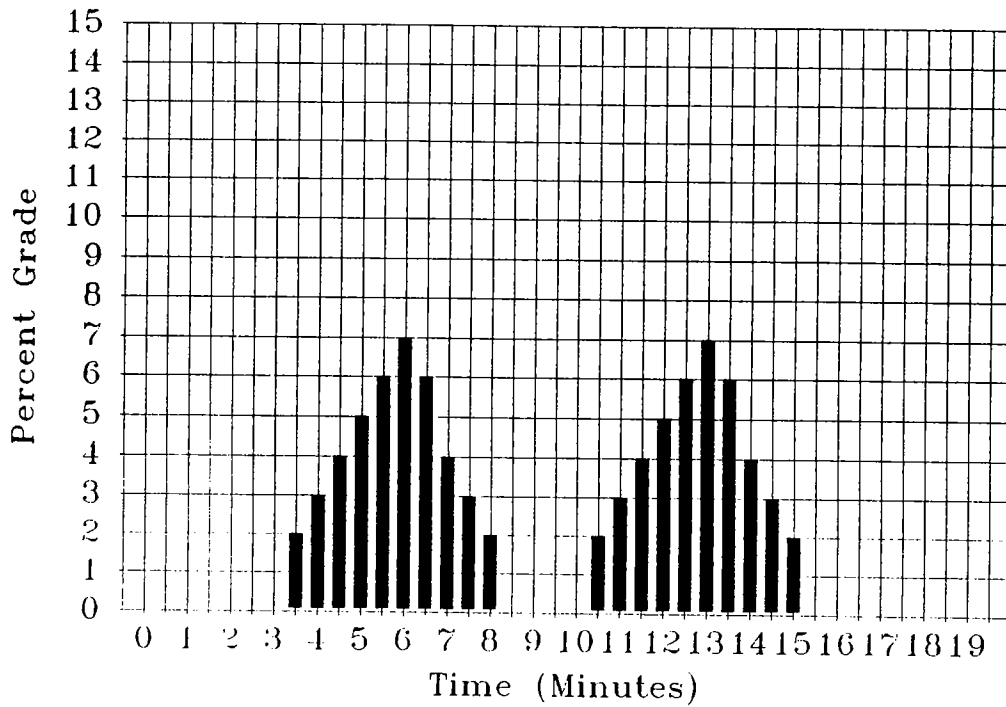

LEGEND
 ■ Elevation
 (Maximum 7%)

Speed

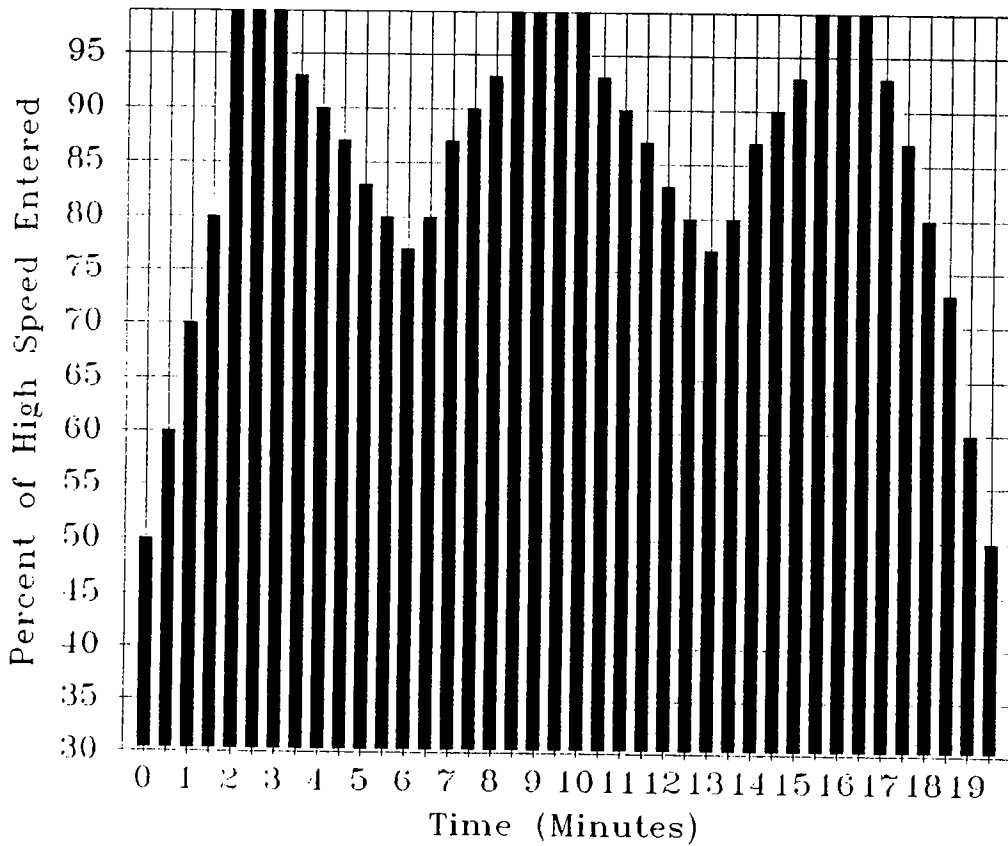

LEGEND
 ■ HiSpeed %

Startrac Terrain Profile
 Program #5
 Elevation

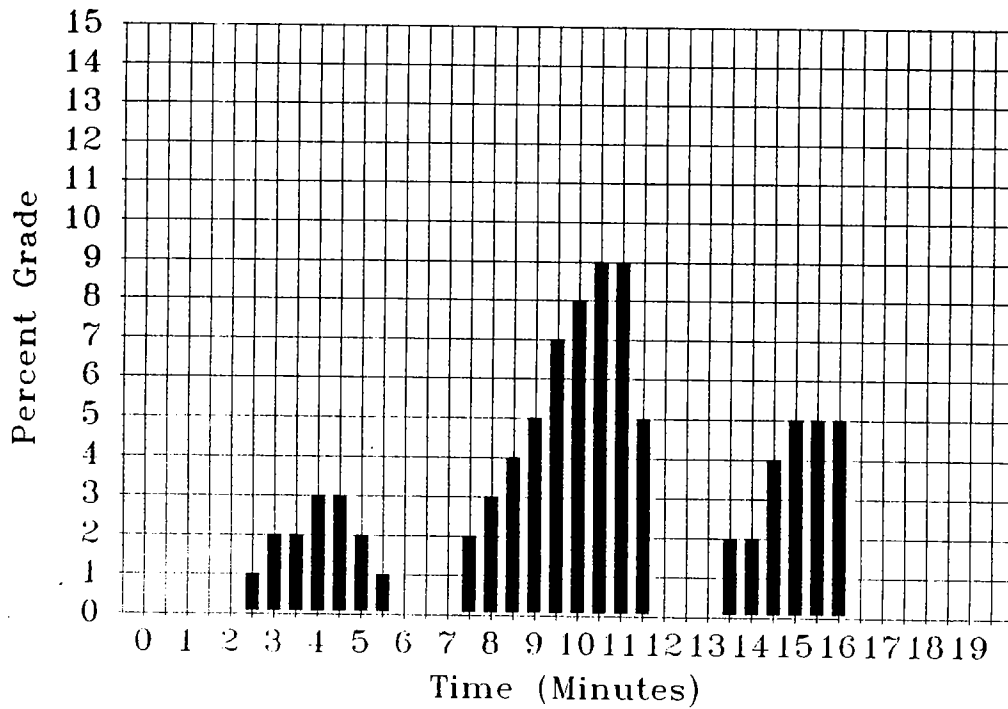

LEGEND
 ■ Elevation
 (Maximum 9%)

Speed

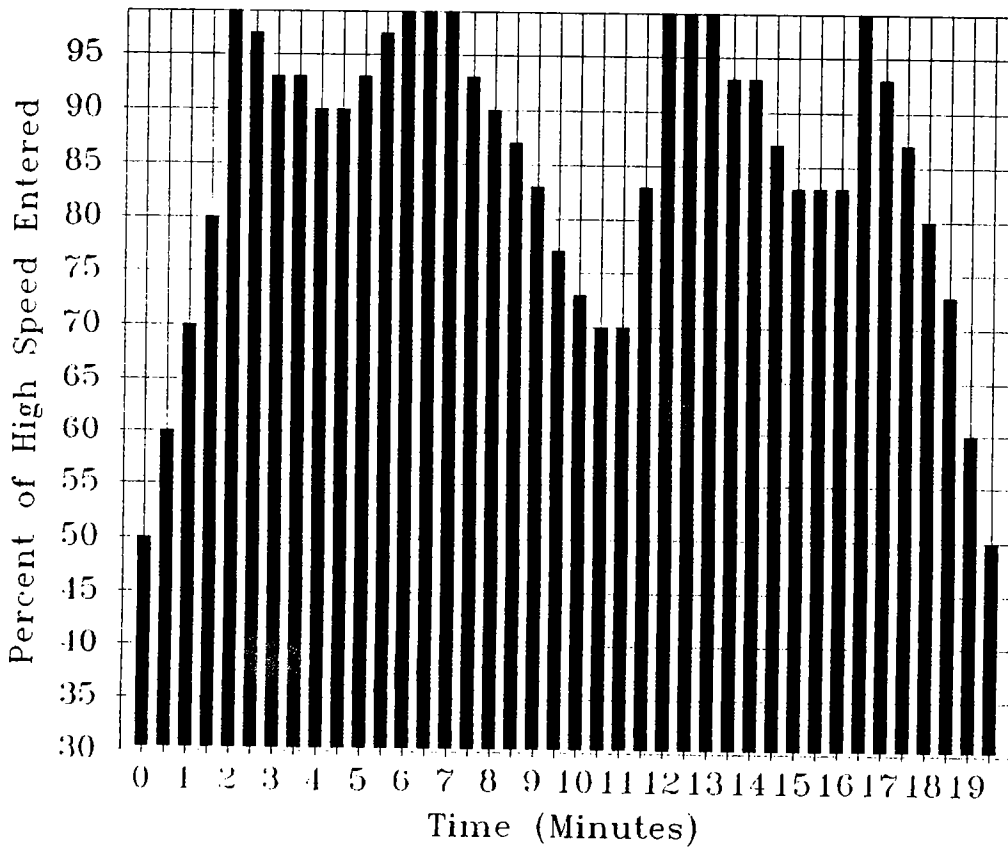

LEGEND
 ■ HiSpeed %

Startrac Terrain Profile
 Program #6
 Elevation

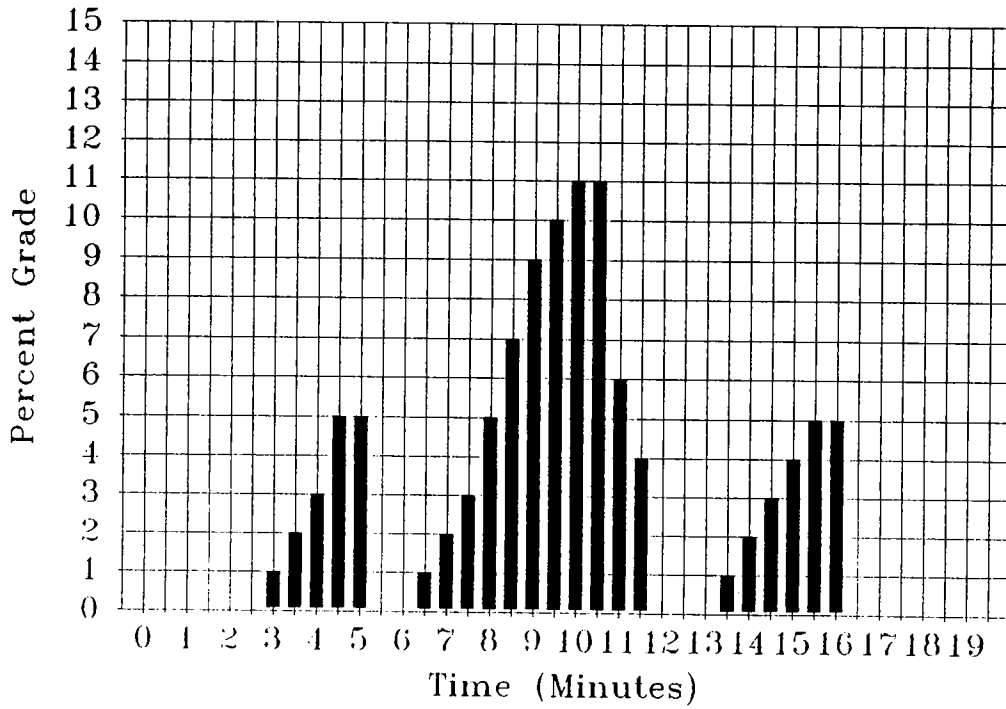

LEGEND
 ■ Elevation
 (Maximum 11%)

Speed

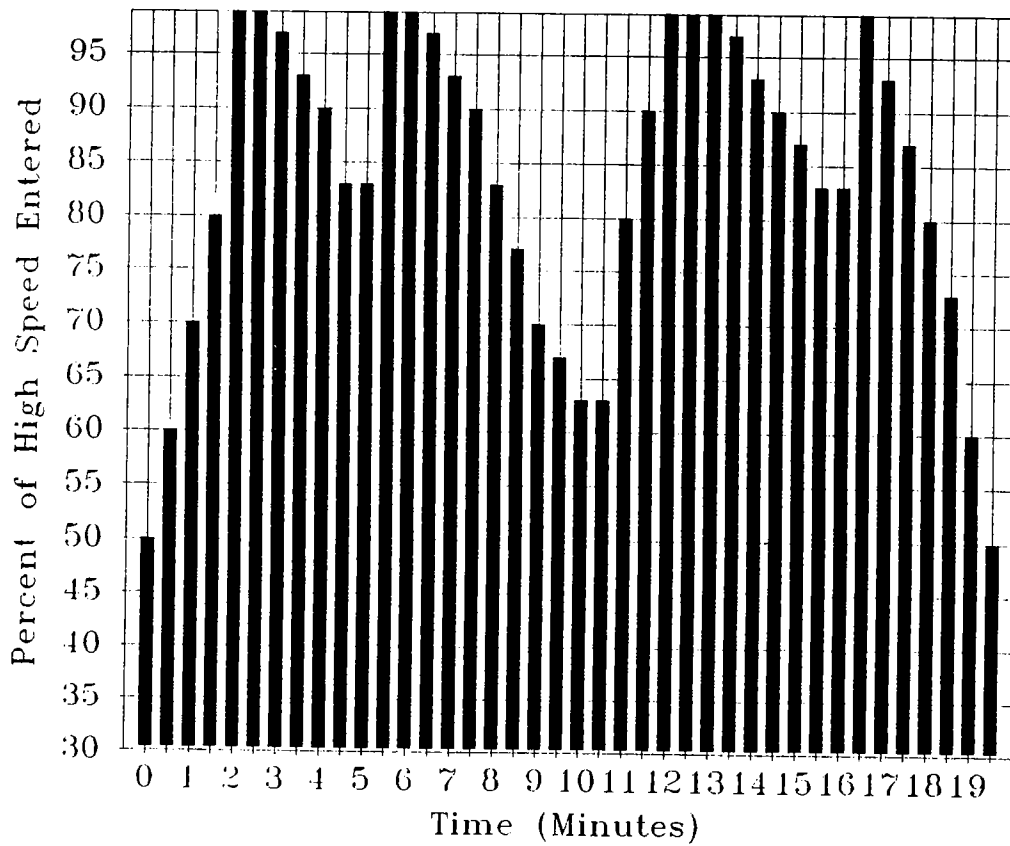

LEGEND
 ■ HiSpeed %

Startrac Terrain Profile
 Program #7
 Elevation

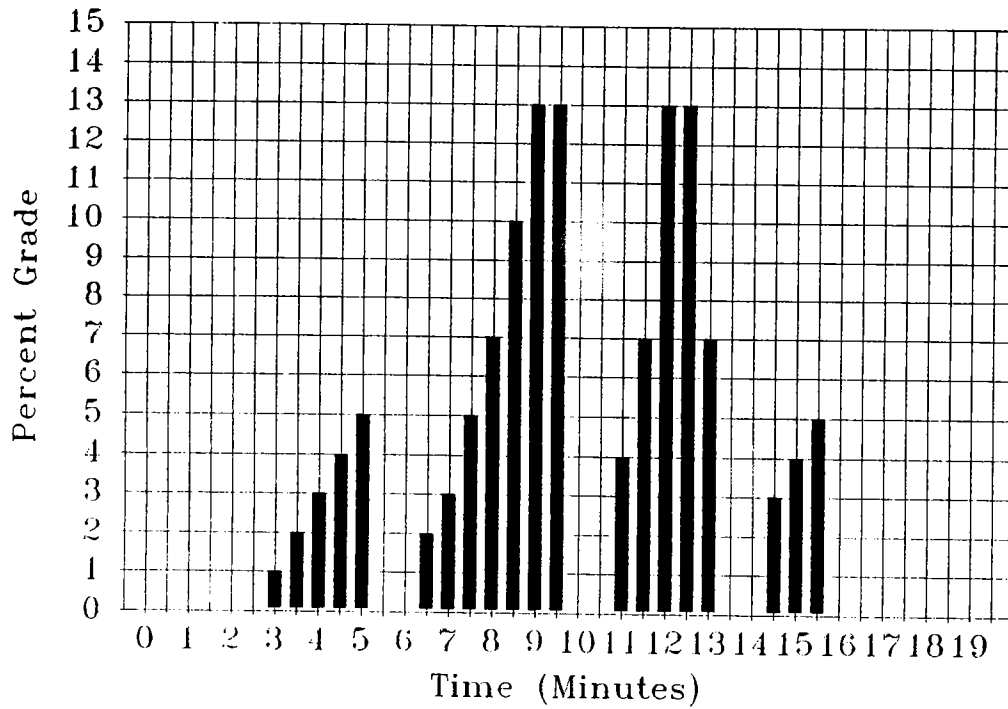

LEGEND
 ■ Elevation
 (Maximum 13%)

Speed

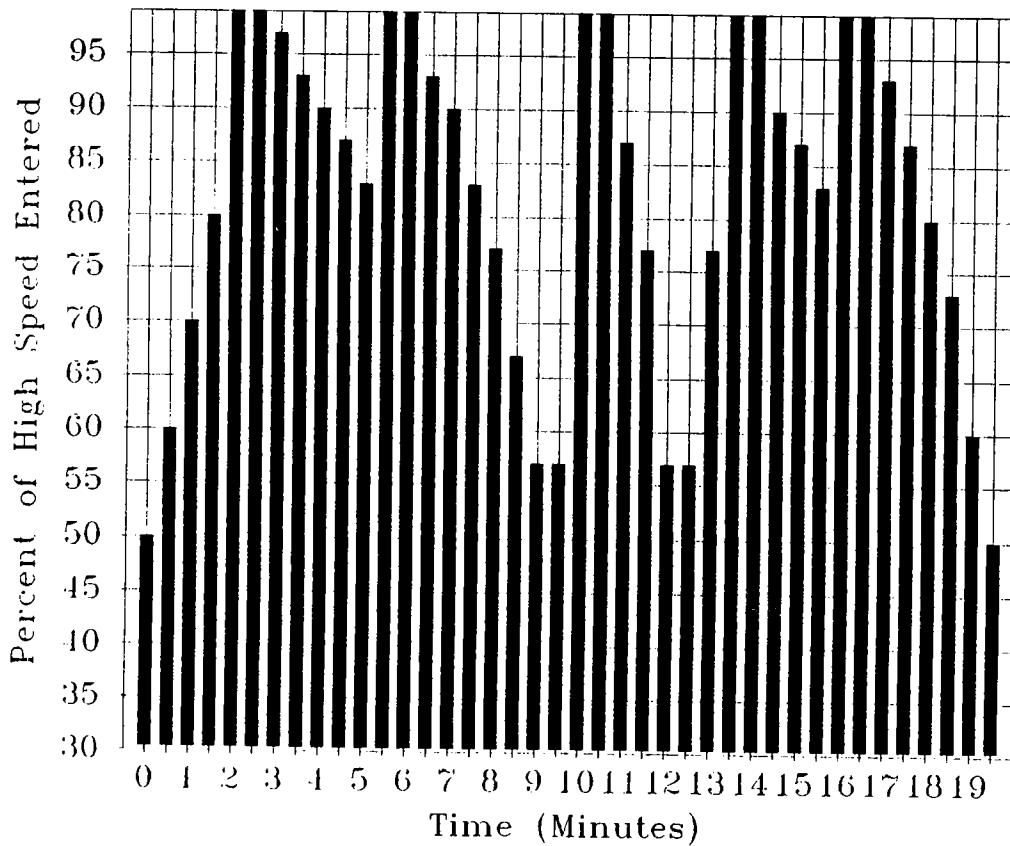

LEGEND
 ■ HiSpeed %

Startrac Terrain Profile
 Program #8
 Elevation

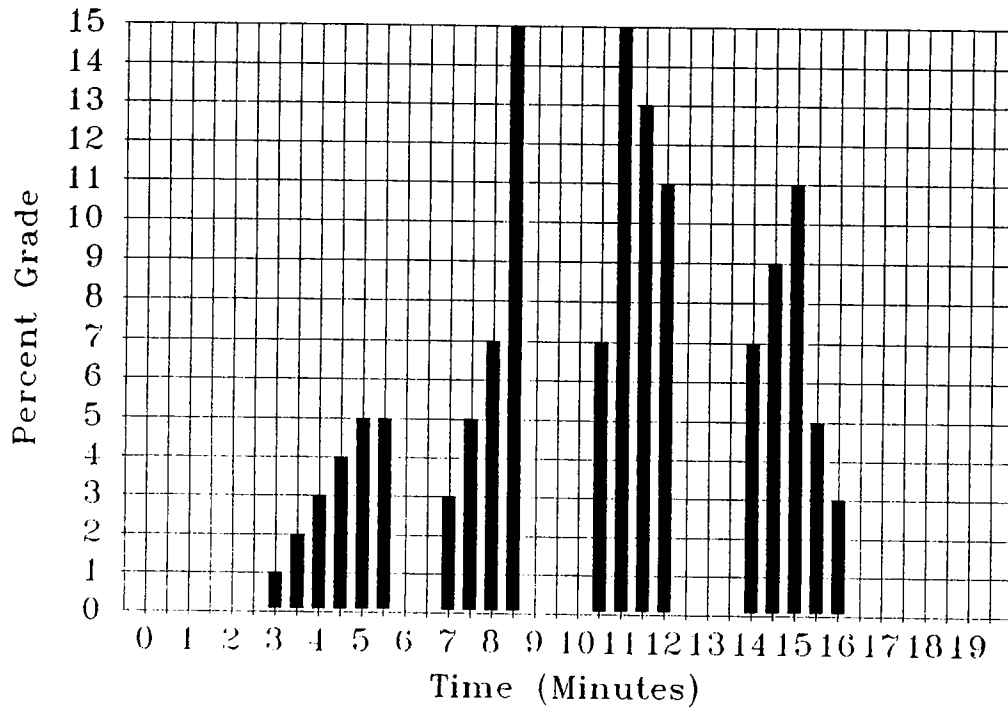

LEGEND
 ■ Elevation
 (Maximum 15%)

Speed

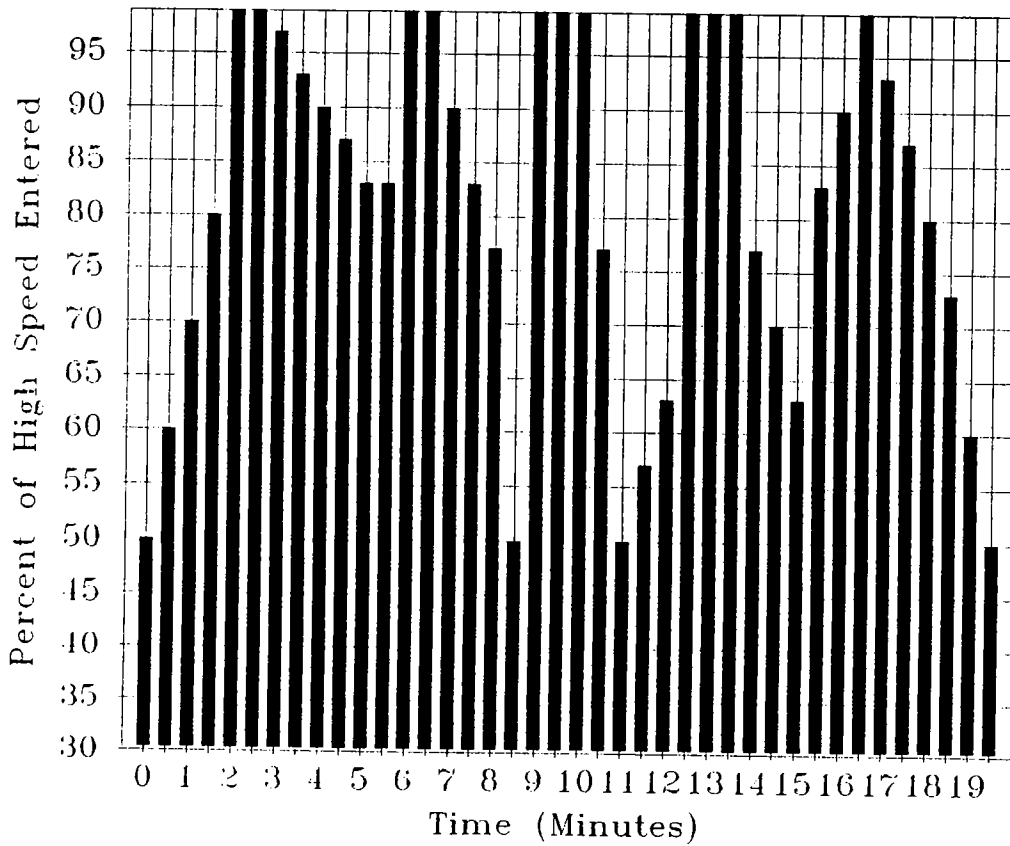

LEGEND
 ■ HiSpeed %

INTERVAL TRAINING

Interval Training (or “LAPS” mode) allows you to program your own terrain of up to five intervals of speed, elevation and distance.

Interval Training is selected and set up as follows:

- When “**CHOOSE 0-9**” is displayed, press the **[9]** or **[LAPS]** key (both will act the same).
- The display now asks you to enter your weight by displaying “**KILOS =**”. Enter your weight (20-199 kg) by pressing the number keys, then press **[ENTER]**.
- At this point, the display will begin requesting the information (speed, elevation and distance) for each interval beginning with “**SPEED 1**” as shown in the table below. You can substitute “PACE” for “SPEED” by pressing the **[DISP]** key. Make your entries using the number keys followed by pressing **[ENTER]** or **[LAPS]**. To program fewer than five intervals, press **[ENTER]** at the “**SPEED**” prompt display. **YOUR PROGRAM BEGINS AFTER THE LAST INTERVAL IS ENTERED AND THE RUNNING BELT WILL START MOVING.**

| DISPLAY | VALUE |
|----------------|---|
| SPEED 1 | speed of first interval |
| ANGLE 1 | elevation during first interval |
| LAPS 1 | “track” laps (100m) for first interval |
| SPEED 2 | speed of second interval |
| ANGLE 2 | elevation during second interval |
| LAPS 2 | “track” laps (100m) for second interval |
| SPEED 3 | speed of third interval |
| ANGLE 3 | elevation during third interval |
| LAPS 3 | “track” laps (100m) for third interval |
| SPEED 4 | speed of fourth interval |
| ANGLE 4 | elevation during fourth interval |
| LAPS 4 | “track” laps (100m) for fourth interval |
| SPEED 5 | speed of fifth interval |
| ANGLE 5 | elevation during fifth interval |
| LAPS 5 | “track” laps (100m) for fifth interval |

Your interval entries will then be executed as specified for the duration of the program (repeating or clipping to complete the workout at 20 minutes). When advancing to the next interval, three warning beeps will sound signifying possible speed and elevation changes.

The oval track display shows your progress around a 100 meter track, starting from bottom center and moving counter-clockwise. As more ground is covered, the tail end of the “comet” circling the track grows, filling (and clearing) the track display every kilometer.

Five beeps signal the end of the program, and the numerical display cycles through “---FINISH---”, your total elapsed time, distance covered, average speed, and your total calories, average calories per hour, and average pace (minutes per kilometer).

While running in *Interval Training*, you can also perform the following functions:

- **STOP / PAUSE** Pressing [**STOP**] once stops the treadmill and “**PAUSES**” operation. You can continue your program by simply pressing the [**START**] key. Pressing [**STOP**] twice (or remaining in “**PAUSE**” mode over 20 seconds) stops the treadmill, cancels your program, and returns you to the “**CHOOSE 0-9**” display.
- **REVIEW INTERVALS** The [**LAPS**] key may be used during interval training to review or alter the choices of speed, elevation and distance made during programming. The numerical keys can be used to set a new speed or pace by simply entering the numbers and pressing [**LAPS**] to enter the value and continue reviewing or [**START**] to enter the value and resume normal display.
- **CHANGE SPEED** The “**SPEED**” or “**PACE**” (selectable with the [**DISP**] key) on the current interval can be set simply by pressing the number keys indicating the desired value and then pressing [**ENTER**]. Speed may also be changed by pressing the [**FAST**] and [**SLOW**] keys which will increase and decrease the speed of the belt as long as they are held down.
- **CHANGE ELEVATION** The [**UP**] and [**DOWN**] arrow keys control elevation for the current interval by moving an elevation target represented by a blinking indicator in the *PERCENT GRADE* display. The treadmill moves up or down until the elevation matches the target. When used in *Interval Training*, the elevation will be set by the program when the next interval is executed.
- **TOGGLE DISPLAY** The [**DISP**] key switches between *Elapsed Time – Distance – Speed* and *Calories per Hour – Total Calories – Pace* on the display. If pressed when you request a speed (km/hr), it changes the display to a **PACE** (minutes per kilometer) mode.
- **PULSE RATE TIMER** The STARTRAC treadmill features a built-in timer which enables you to monitor your pulse rate when the program is paused or finished. Activate the timer by pressing the [**LAPS**] key when the display reads “---PAUSE---” or “---FINISH---”. The timer beeps every 6 seconds. To obtain your heart rate, count pulses between beeps and multiply by 10. The timer can be reset **ANY** time by pressing the [**LAPS**] key.

MANUAL OPERATION

Manual Operation is accessed by pushing the **[SLOW]** key. The running belt will start moving and gradually speed up to 1 km/hr. Once started, you can select your running speed (in 1/10 km/hr increments) and adjust track elevation between 0 and 15 percent grade (in 1 percent increments). *Manual Operation* is open-ended and continues until you choose to stop.

The oval track display shows your progress around a 100 meter track, starting from bottom center and moving counter-clockwise. As more ground is covered, the tail end of the “comet” circling the track grows, filling (and clearing) the track display every kilometer.

To end your program, press **[STOP]** once. The numerical display cycles through “---PAUSE---”, your total elapsed time, distance covered, average speed, and your total calories, average calories per hour, and average pace (minutes per kilometer). Pressing **[STOP]** again or remaining in the “PAUSE” mode over 20 seconds will return you to the “CHOOSE 0-9” display (see *STOP / PAUSE* below).

While running in *Manual Operation*, you can also perform the following functions:

- **STOP / PAUSE** Pressing **[STOP]** once stops the treadmill and “PAUSES” operation. You can continue your program by simply pressing the **[START]** key. Pressing **[STOP]** twice (or remaining in “PAUSE” mode over 20 seconds) stops the treadmill, cancels your program, and returns you to the “CHOOSE 0-9” display.
- **CHANGE SPEED** The current “SPEED” or “PACE” (selectable with the **[DISP]** key) can be set simply by pressing the number keys indicating the desired value and then pressing **[ENTER]**. Speed may also be changed by pressing the **[FAST]** and **[SLOW]** keys which will increase and decrease the speed of the belt as long as they are held down.
- **CHANGE ELEVATION** The **[UP]** and **[DOWN]** arrow keys control elevation by moving an elevation target represented by a blinking indicator in the *PERCENT GRADE* display. The treadmill moves up or down until the elevation matches the target.
- **TOGGLE DISPLAY** The **[DISP]** key switches between *Elapsed Time – Distance – Speed* and *Calories per Hour – Total Calories – Pace* on the display. If pressed when you request a speed (km/hr), it changes the display to a **PACE** (minutes per kilometer) mode.
- **PULSE RATE TIMER** The STARTRAC treadmill features a built-in timer which enables you to monitor your pulse rate when the program is paused or finished. Activate the timer by pressing the **[LAPS]** key when the display reads “---PAUSE---”. The timer beeps every 6 seconds. To obtain your heart rate, count pulses between beeps and multiply by 10. The timer can be reset **ANY** time by pressing the **[LAPS]** key.

ADVANCED MANUAL OPERATION

Advanced Manual Operation combines the manual speed and elevation controls of normal *Manual Operation* with the time duration and accurate weight based Calorie computations of the other operating modes on the treadmill.

Advanced Manual Operation is implemented as follows:

- When “**CHOOSE 0-8**” is displayed, press **[0]** key to select *Advanced Manual Operation*.
- The display next asks for the duration of the program, displaying “**DURATION =**”. Using the number keys, enter the program duration (**10 - 99 minutes**), and press **[ENTER]**. Note: Entries of 1-9 will be multiplied by 10 (i.e., entering 2 will result in a 20 minute run).
- The display now asks you to enter your weight by displaying “**POUNDS =**”. Enter your weight (40-399 lbs.) by pressing the number keys, then press **[ENTER]**.
- Next, enter your initial speed (1.0-10.0 MPH) at the “**SPEED =**” prompt, or press **[DISP]** to change the display to read “**PACE =**” (Minutes per mile). **AS SOON AS THE SPEED OR PACE IS KEYED IN AND [ENTER] IS PRESSED, THE RUNNING BELT WILL START MOVING.**

The oval track display shows your progress around a 100 yard (1/16 mile) track, starting from bottom center and moving counter-clockwise. As more ground is covered, the tail end of the “comet” circling the track grows, filling (and clearing) the track display every mile.

Five beeps signal the end of the run, and the display cycles through “**---FINISH---**”, your total elapsed time, distance covered, average speed, and your total calories, average calories per hour, and average pace (minutes per mile).

While running in *Advanced Manual Operation*, you can also perform the following functions:

- **STOP / PAUSE** Pressing **[STOP]** once stops the treadmill and “**PAUSES**” operation. You can continue your program by simply pressing the **[START]** key. Pressing **[STOP]** twice (or remaining in “**PAUSE**” mode over 20 seconds) stops the treadmill, cancels your program, and returns you to the “**CHOOSE 0-8**” display.
- **CHANGE SPEED** The current “**SPEED**” or “**PACE**” (selectable with the **[DISP]** key) can be set simply by pressing the number keys indicating the desired value and then pressing **[ENTER]**. Speed may also be changed by pressing the **[FAST]** and **[SLOW]** keys which will increase and decrease the speed of the belt as long as they are held down.
- **CHANGE ELEVATION** The **[UP]** and **[DOWN]** arrow keys control elevation by moving an elevation target represented by a blinking indicator in the *PERCENT GRADE* display. The treadmill moves up or down until the elevation matches the target.

- **TOGGLE DISPLAY** The **[DISP]** key switches between *Elapsed Time—Distance—Speed* and *Calories per Hour—Total Calories—Pace* on the display. If pressed when you request a speed (**km/hr**), it changes the display to a **PACE** (minutes per kilometer) mode.
- **PULSE RATE TIMER** The STARTRAC treadmill features a built-in timer which enables you to monitor your pulse rate when the program is paused or finished. Activate the timer by pressing the **[LAPS]** key when the display reads “**---PAUSE---**” or “**---FINISH---**”. The timer beeps every 6 seconds. To obtain your heart rate, count pulses between beeps and multiply by 10. The timer can be reset **ANY** time by pressing the **[LAPS]** key.

INDICATORS AND DISPLAYS

During operation, a vertical row of indicator LED's represents target elevation and actual elevation from 0% to 15% grade. Program indicator LED's 1 through 8 display the selected program. A graphic display shows the runner's progress around a 100 meter oval track. Digital displays show either “**ELAPSED TIME**” in minutes and seconds, “**DISTANCE**” traveled in kilometers and “**SPEED**” in km/hr or “**CALORIES PER HOUR**”, “**TOTAL CALORIES**” and “**PACE**” in minutes per kilometer, depending on the indicators surrounding the digital display (selected with the **[DISP]** key).

The oval track display shows your progress around a 100 meter track, starting from bottom center and moving counter-clockwise. More of the track lights up as more ground is covered. In *Pre-Set Elevation Terrains*, the track lights fill based on progress in the program, lighting the entire track by the end of a program. In the other operating modes, at the end of each kilometer, all track LED's are illuminated and at the start of the next kilometer (i.e., the 11th lap) all track LED's are switched off, starting the process over again.

Three warning beeps indicate a programmed (*Pre-Set Elevation Terrain* or *Interval Training*) setting of the speed and elevation is being implemented.

Five beeps signal the end of the program, and the numerical display cycles through “**---FINISH---**”, your total elapsed time, distance covered, average speed, and your total calories, average calories per hour, and average pace (minutes per kilometer).

PULSE RATE TIMER

The **STARTRAC** treadmill features a built-in timer which enables you to monitor your pulse rate when the program is paused or finished. Activate the timer by pressing the **[LAPS]** key when the display reads “**---PAUSE---**” or “**---FINISH---**”. The timer beeps every 6 seconds. To obtain your heart rate, count pulses between beeps and multiply by 10. The timer can be reset **ANY** time by pressing the **[LAPS]** key.

DIAGNOSTIC TEST MODES

DISPLAY TEST MODE

Test the display circuit board by holding the **[5]** key down while switching the treadmill on. All the displays stay lit until a key is pressed, whereupon the software revision number is displayed. Pressing different keys, other than **[STOP]**, illuminate different patterns on the display. Pressing **[STOP]** ends the display board test.

MOTOR TEST MODE

WARNING: DO NOT RUN ON THE TREADMILL IN MOTOR TEST MODE.

Enter the Motor Test Mode by turning the treadmill power switch ON with the **[8]** key depressed. Alternate LED's in the track display blink twice per second.

The numeric displays show elevation motor **Revolutions Per Second**, speed command number (**SCN**) as a number between 3 and 240 and belt speed in **km/hr**:

| ELAPSED TIME (RPS) | DISTANCE (SCN) | SPEED (km/hr) |
|-----------------------|-------------------|------------------|
| -50 | 45 | 8.7 |

The Program indicator LED's show the state of various sensors:

| | |
|---|----------------------|
| 1 | "RPM" sensor ON |
| 2 | "RPM" sensor ON |
| 3 | Elevation sensor ON |
| 4 | 0% sensor ON |
| 5 | "RPM" sensor OFF |
| 6 | "RPM" sensor OFF |
| 7 | Elevation sensor OFF |
| 8 | 0% sensor OFF |

The **[FAST]** key increases and the **[SLOW]** key decreases the speed command number (**SCN**).

The **[UP]** and **[DOWN]** keys set the elevation direction relay when pressed; hold either key for more than half a second to run the elevation motor.

Use the **[LAPS]** key to test the watchdog circuit on the motor control board, disabling both motors. The running belt and elevation motors will not operate until power is turned off and re-started.

The **[START]** key begins the “**Burn-In**” program. Error detection is enabled.

The **[0] - [9]** number and **[DISP]** keys are ignored.

The **[STOP]** key exits to the “**CHOOSE 0-9**” opening display.

NOTES:

- Elevation RPS display updates twice per second.
- Downward motion displays with a minus sign.
- Speed display updates ten times per second.

The **[UP]** and **[DOWN]** keys switch the direction relay immediately, even if the elevation motor is moving. The motor does not stop automatically on the zero percent switch. Changing direction while elevation is running should be avoided.

Except during “**Burn-In**”, the unit will not detect elevation errors, but will detect all “**CPU Errors**” and “**SPd Error 1**”.

ERROR MESSAGES

STARTRAC Displays Error Messages when the computer detects a malfunction. **Please record the Error Type AND Number displayed.** This information, along with the definition of Error Messages in the troubleshooting section, will tell the repair person what to do.

Error messages can be cleared only by switching off power to the treadmill.

For service, contact **UNISEN, INC., STARTRAC Field Service at 1-800-228-6635, outside California; 714-669-1660 inside California and outside USA.**

CPU ERROR

If **STARTRAC** detects a fault in its internal operations it will stop and display “**CPU Error 0 or 1 or 2**” (Probably caused by turning the treadmill **OFF** and **ON** too quickly - the microprocessor is not reset and also trips the circuit watchdog). Turn the power switch **OFF**, wait a couple of seconds and then turn the power switch **ON**. If the problem occurs again, contact Unisen for assistance.

ELEVATION ERROR

If a problem develops with the elevation mechanism, “**EI Error 0,1,2 or 3**” is displayed and the treadmill stops.

Possible causes of this error include a stalled elevation motor, a defective elevation sensor or cable, or a defective zero percent sensor or cable.

To allow operation of the treadmill until elevation can be serviced, depress the **[0]** key while switching the machine on. In this mode, “**EL-OFF**” will appear for several seconds at power up and no elevation operations will occur.

FAIL-SAFE ERROR

If the microprocessor detects the fail-safe (watchdog) circuit tripped on the motor control board at the start or during a run, the display will show "FS Error 0". Possible causes for this are cycling power too fast (see CPU ERROR), defective motor control board or defective display cable.

SPEED ERROR

The display reads "**SPEED Error 0,1, or 2**" when the microprocessor detects a problem with the motor speed control.

THIS MAY SHOW AN UNSAFE CONDITION

Possible causes are a defective or misadjusted motor speed sensor / cable or motor control board.

BELT ADJUSTMENTS

RUNNING BELT

Belt tracking adjustments may become necessary. The adjustment bolts are at the tail roller and require a 1/4" (6.35mm) Hex Key Driver. Turning the right bolt clockwise will cause the belt to move to the left and vice versa. Adjust one bolt only half a turn at a time. Run the belt slowly at 3-5 km/hr while adjusting, then run it fast for 30 seconds or more to check the result. Adjust the belt to ride in the center of the running surface and motor shroud.

MOTOR BELT

The motor drive belt might require tensioning during normal use. Adjust the motor belt tension to eliminate slippage. The adjusting procedure is as follows:

Unplug the unit and lift the motor shroud. Loosen the motor bolts and tension bolt lock nut. Turn the tension bolt 1/4 turn clockwise. Tighten tension bolt lock nut and motor bolts. Position the motor shroud, and plug the unit in.

ELEVATION BELT

We designed and engineered the elevation belt and pulley assembly for years of trouble free use; however, if the belt and assembly needs servicing or if you hear a “popping” noise when using the elevation system proceed as follows:

1. Elevate the treadmill to a 10% grade.
2. Unplug the unit, lift the motor shroud and place a piece of carpet or other soft material next to the equipment.
3. Carefully tip the unit on its side and inspect the belt tension. A 6mm deflection with moderate pressure is acceptable.
4. If more tension is necessary, loosen the 1/2” (12.7mm) bolt retaining the idler pulley assembly. Increase the tension to a 6mm deflection by moving the idler pulley.
5. Tighten the 1/2” (12.7mm) idler assembly bolt.
6. Return the unit to an upright position, plug it in and check the operation of the elevation mechanism. If it's working satisfactorily, unplug the power cord, lower and position the motor shroud and reinsert the plug.

RUNNING BED

The phenolic material laminated running bed surface is coated with a “wax-like” substance. During the break-in period, (20-30 hrs. of operation), this material may “migrate” along the surface of the running bed and accumulate on the head and tail rollers. This accumulation could cause a slight “thumping” noise. If the thumping noise persists after a prolonged period of time, you should remove some of the accumulation from the tail roller. The procedure is as follows:

1. Turn the belt adjustment bolts counter-clockwise with the 1/4” (6.35mm) Hex Key Driver far enough to loosen the running belt.
2. Remove the largest accumulations of the “wax-like” material. **DO NOT** remove all the substance, as it is needed to lubricate the running bed and belt.
3. Turn the belt adjustment bolts clockwise and adjust the belt to ride in the center of the running surface and motor shroud. **DO NOT** over tighten, as this will distort the shape of the running belt.

Designed and manufactured by **UNISEN, INC.**

14352 Chambers Road
Tustin, California 92680

(714) 669-1660
USA Outside CA (800) 228-6635

Copyright © 1987, 1990 **UNISEN, INC.** All rights reserved.

TROUBLESHOOTING CHART

Please note the Error Message on the display before calling Unisen's Startrac Field Service department.

| ERROR MESSAGE | PROBABLE CAUSES | SOLUTION |
|--|--|---|
| "CPU Error 0" (wandering program) <u>or</u> "CPU Error 1" (.1 second flag missed) <u>or</u> "CPU Error 2" (snooper routine) | 1. Power switch "OFF/ON" cycled too fast. 2. Low voltage at CPU. 3. Intermittent connection display cable at display board or motor control board. 4. Faulty digital logic on display board. | 1. Shut power switch "OFF", wait two seconds, then turn "ON". 2. Check voltage (5V +/-5%) and consult Unisen. 3. Power down, disconnect, then reconnect both ends of display cable. 4. Replace display board. |
| "EI Error 0" (0% grade sensor seen above 1% grade) | 1. Elevation belt broken or disconnected from pulley. 2. Elevation motor drive pulley slipping on the motor shaft. 3. 0% switch defective. | 1. Replace elevation belt and re-align. 2. Tighten elevation motor pulley set screws. 3. Replace 0% switch. |
| "EI Error 1" (Elevation stalled) | 1. Elevation screws binding. 2. Elevation screws dirty. 3. Open circuit in elevation motor. | 1. Lubricate with light oil. 2. Clean and lubricate elevation screws. 3. Check elevation motor brushes and connector. |
| "EI Error 2" (Elevation runaway) | 1. Shorted SCR in elevation circuit. 2. Excessive coasting after running elevation. | 1. Replace M.C.B. (motor control board). 2. Reduce elevation speed / power pot setting. |
| "EI Error 3" (Stall during preset) | 1. Disconnected elevation motor. 2. Misadjusted elevation count sensor. 3. 0% switch defective or trip plate missing. | 1. Check elevation motor connector. 2. Readjust elevation count sensor. 3. Replace 0% switch and/or install trip plate. |

TROUBLESHOOTING CHART

Please note the Error Message on the display before calling Unisen's Startrac Field Service department.

| ERROR MESSAGE | PROBABLE CAUSES | SOLUTION |
|--|---|--|
| <p>"FS Error 0" (Fail-Safe Tripped)</p> | <ol style="list-style-type: none"> 1. Power switch "OFF/ON" cycled too fast. 2. Faulty motor control board. 3. Faulty display cable. 4. Attempting to run after executing watchdog trip (page 17) in motor test mode. | <ol style="list-style-type: none"> 1. Shut power switch "OFF", wait two seconds, then turn "ON". 2. Contact Unisen or replace M.C.B. 3. Contact Unisen or replace display cable. 4. Shut power switch "OFF", wait two seconds, then turn "ON". |
| <p>"Spd Error 0" (Loss of feedback)</p> | <ol style="list-style-type: none"> 1. Disconnected speed sensor. 2. Flywheel abrading speed sensor cable. 3. Misaligned speed sensor (relative to RPM disc). 4. Faulty speed sensor. | <ol style="list-style-type: none"> 1. Check speed sensor cable. 2. Repair or replace speed sensor cable. 3. Reposition sensor to read RPM disc. 4. Replace speed sensor cable assembly. |
| <p>"Spd Error 1" (Sudden change in speed greater than 2 MPH)</p> | <ol style="list-style-type: none"> 1. Misadjusted or faulty motor control board. | <ol style="list-style-type: none"> 1. Contact Unisen or replace M.C.B. |
| <p>"Spd Error 2" (Initial feedback loss)</p> | <ol style="list-style-type: none"> 1. If motion before error, feedback loss. 2. Misadjusted or faulty motor control board. 3. Power switch "OFF/ON" cycled too fast. | <ol style="list-style-type: none"> 1. See "Spd Error 0". 2. Contact Unisen or replace M.C.B. 3. Shut power switch "OFF", wait two seconds, then turn "ON". |

STAR BY UNISEN, INC.

TRAC 1400

ASSEMBLY INSTRUCTIONS

TREADMILLS DESIGNED AND MANUFACTURED BY UNISEN INC.

14352 CHAMBERS RD. ● TUSTIN, CALIFORNIA 92680

(714) 669-1660 ● (800) 228-6635

FAX (714) 838-6286

STARTRAC 1400

ASSEMBLY INSTRUCTIONS

1. LIFT THE DISPLAY PANEL HANDRAIL AND SLIDE THE MOTOR COVER HALFWAY UP THE HANDRAILS. USE A BUNGY CORD TO SUSPEND THE MOTOR COVER WHILE INSTALLING THE DISPLAY HANDRAIL.

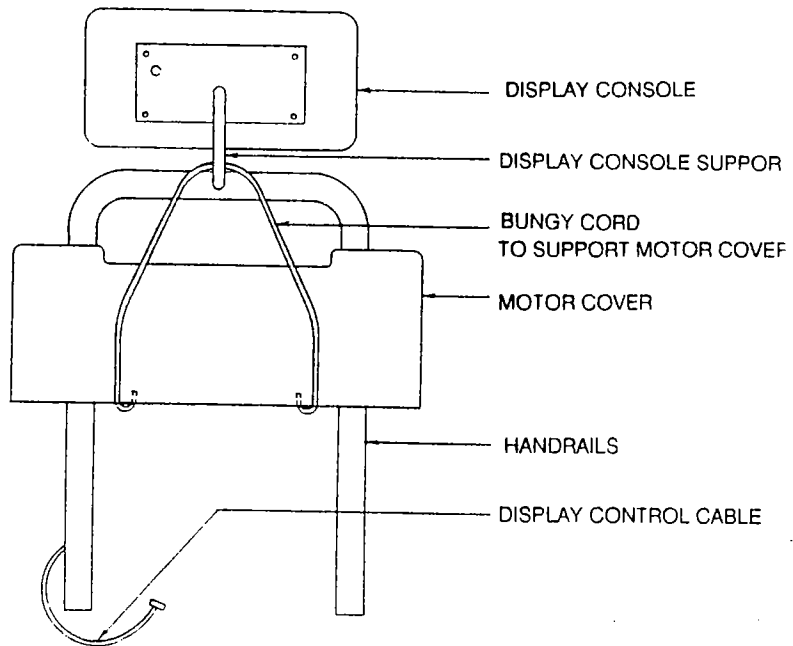

2. USE THE 9/16" WRENCH TO LOOSEN U-BOLTS NUTS, AND WASHERS AND PUSH BOTH U-BOLTS IN.

DO NOT LOOSEN THE STOP BOLTS.

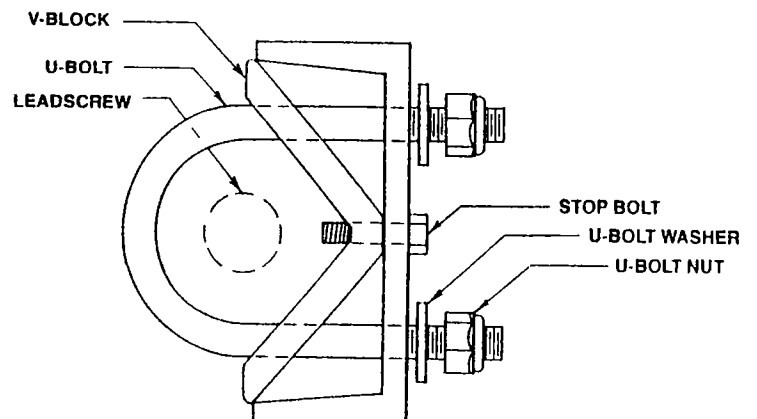

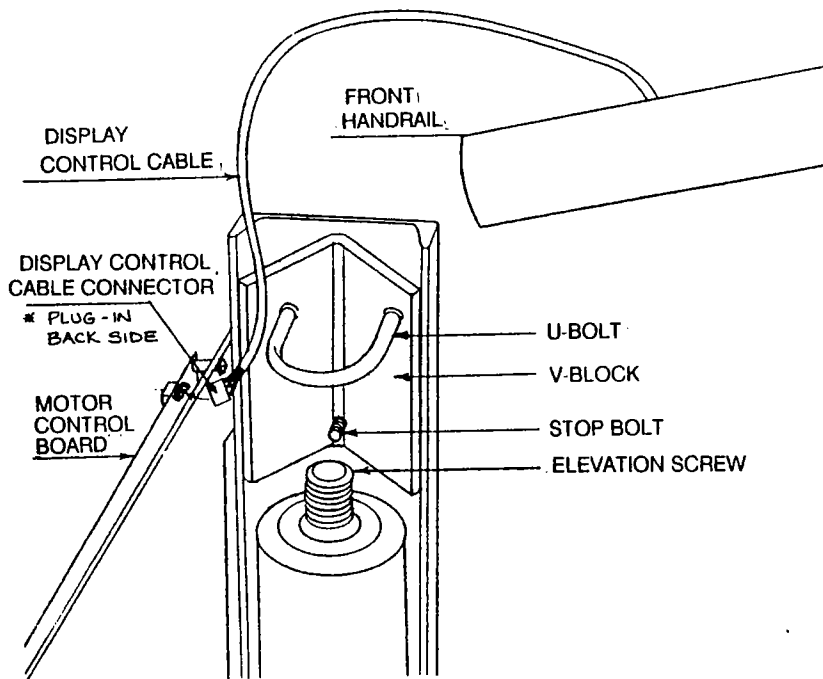

3. CAREFULLY PLACE THE DISPLAY HANDRAIL, INCLUDING THE MOTOR COVER AND OPEN ENDS OF THE DISPLAY HANDRAIL TOWARDS THE U-BOLTS ON THE RUNNING SURFACE. ROUTE THE DISPLAY CONTROL CABLE AS SHOWN AND PLUG INTO THE MOTOR CONTROL PRINTED CIRCUIT BOARD JACK.

4. CAREFULLY LIFT THE DISPLAY HANDRAIL AND MOTOR COVER.

LOWER THE DISPLAY HANDRAIL AND INSERT THE ELEVATION SCREWS INTO THE HANDLES.

GUIDE THE DISPLAY HANDRAIL THROUGH THE U-BOLTS AND DOWN TO THE STOP BOLTS.

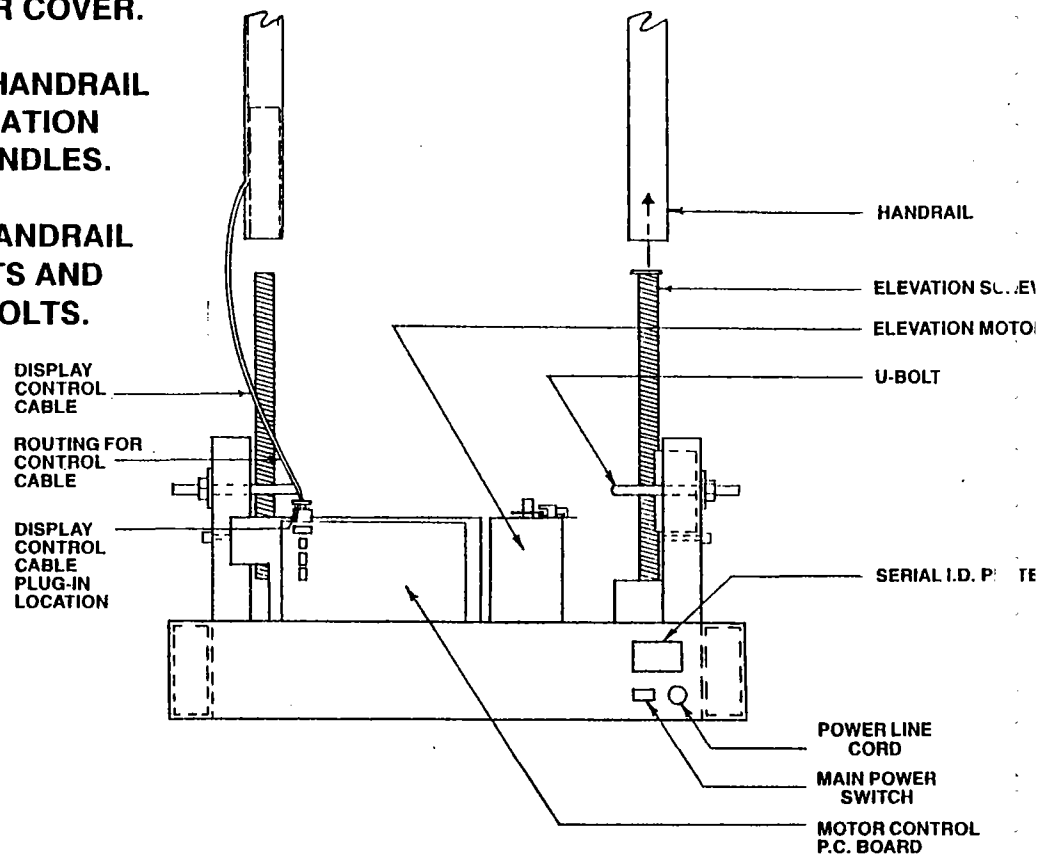

IMPORTANT

MAKE SURE THAT THE DISPLAY CONTROL CABLE DOES NOT TOUCH OR IS PINCHED BY THE ELEVATION SCREWS.

LONG SIDE HANDRAIL IS EQUIPPED WITH REMOTE-STOP SWITCH.
 SHORT SIDE HANDRAIL IS THE SAME WITHOUT REMOTE-STOP SWITCH.

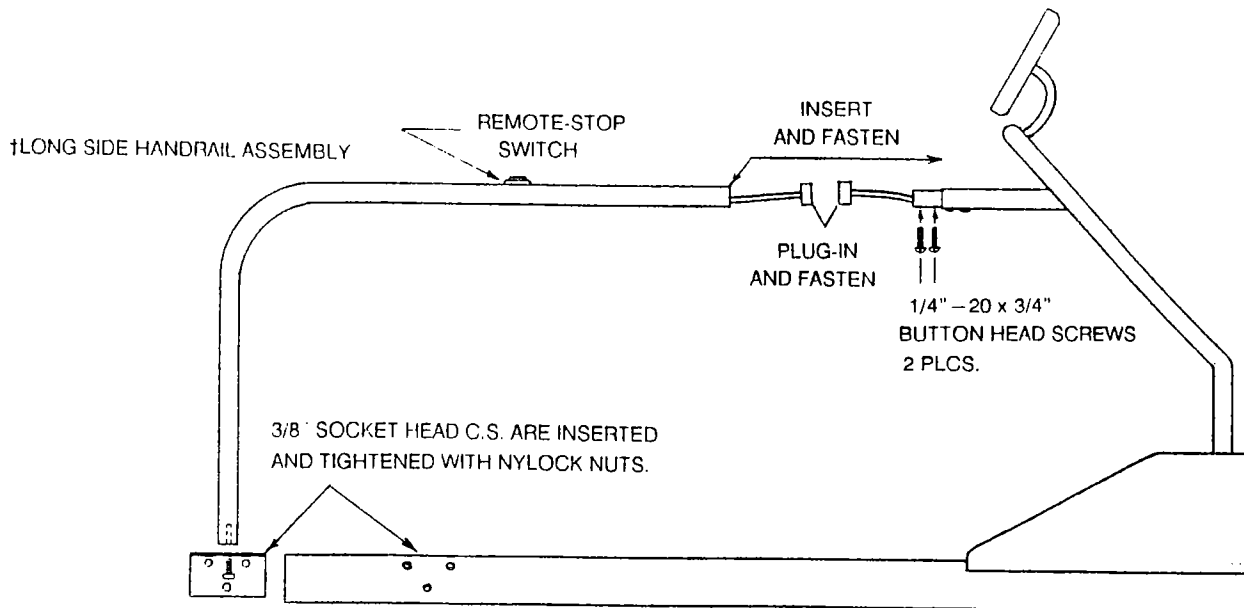

5. NORMALLY, THE SIDE HANDRAILS ARE PLACED WITH THE LONG SIDE HANDRAIL (WITH THE REMOTE-STOP SWITCH) ON THE LEFT SIDE. IF YOU WISH TO PLACE THE LONG SIDE HANDRAIL ON THE RIGHT SIDE, PLUG THE OPEN HOLES IN THE FRAME, LOCATE THE PRE-DRILLED HOLES COVERED BY THE LEXAN STARTRAC LABEL AND CUT NEW HOLES AS SHOWN ON PAGE A-7.

6. ASSEMBLE THE SIDE HANDRAILS BY CONNECTING THE REMOTE-STOP CABLES ON THE LONG SIDE HANDRAIL. INSERT THE SIDE HANDRAIL INTO THE FRONT HANDRAIL, ALIGN THE SCREW HOLES AND INSERT THE 1/4"-20 x 3/4" SCREWS. USE THE SAME PROCEDURE FOR THE OTHER SIDE HANDRAIL. TIGHTEN ALL FOUR SCREWS SECURELY. WITH THE TREADMILL ON A LEVEL SURFACE, POSITION THE BOTTOM OF THE SIDE HANDRAIL AT THE BRACKET, ALIGN THE PRE-DRILLED HOLES AND INSERT THE 5/16" S.H.C.S. BOLT. ADJUST THE SIDE HANDRAIL FOR PROPER FIT AND REPEAT FOR THE OTHER SIDE HANDRAIL.

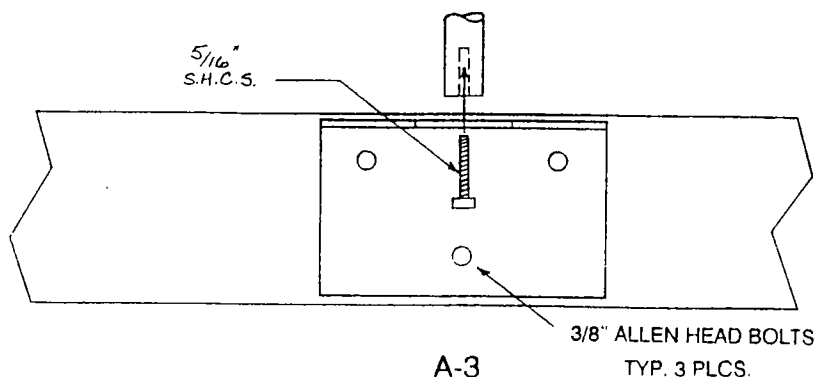
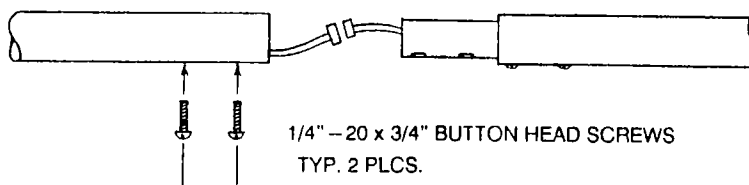

7. USE THE 9/16" WRENCH TO TIGHTEN THE U-BOLT NUTS.
8. CAREFULLY SLIDE THE MOTOR COVER DOWN THE DISPLAY HANDRAILS, MAKING SURE THE SLOT ON THE DIRT STOP CLEARS MOTOR TENSIONING BOLT AND SET IN POSITION.
9. PLUG THE LINE CORD INTO THE POWER OUTLET.
10. MAKE SURE THE LINE CORD DOES NOT GET PINCHED BY ANY MOVING PARTS.
11. TURN UNIT ON AT THE RED MAIN SWITCH.
12. READ THE OPERATOR AND OWNER'S MANUAL FOR THE PROPER USE OF SPEED, ELEVATION AND PROGRAM KEYS.

BELT ADJUSTMENTS

RUNNING BELT

Belt tracking adjustments may become necessary. The adjustment bolts are at the tail roller and require a 1/4" (6.35mm) Hex Key Drive. Turning the right bolt clockwise will cause the belt to move to the left and vice versa. Adjust one bolt only half a turn at a time. Run the belt slowly at 2-3 MPH (3-5 km/hr) while adjusting, then run it fast for 30 seconds or more to check the result. Adjust the belt to ride in the center of the running surface and motor shroud.

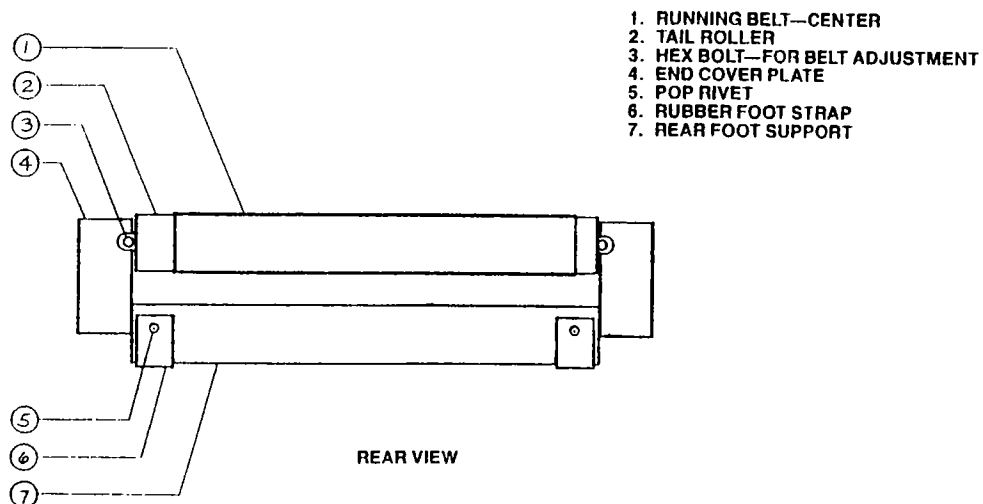

MOTOR BELT

The motor drive belt might require tensioning during normal use. Adjust the motor belt tension to eliminate slippage. The adjusting procedure is as follows:

Unplug the unit, unscrew and lift the motor shroud. Loosen the motor bolts and tension bolt lock nut. Turn the tension bolt 1/4 turn clockwise. Tighten tension bolt lock nut and motor bolts. Position the motor shroud, and plug the unit in.

ELEVATION BELT

We designed and engineered the elevation belt and pulley assembly for years of trouble free use; however, if the belt and assembly needs servicing or if you hear a "popping" noise when using the elevation system proceed as follows:

1. Elevate the treadmill to a 10% grade.
2. Unplug the unit, lift the motor shroud and place a piece of carpet or other soft material next to the equipment.
3. Carefully tip the unit on its side and inspect the belt tension. A 1/4" (6mm) deflection with moderate pressure is acceptable.
4. If more tension is necessary, loosen the 1/2" (12.7mm) bolt retaining the idler pulley assembly. Increase the tension to a 1/4" (6mm) deflection by moving the idler pulley.
5. Tighten the 1/2" (12.7mm) idler assembly bolt.
6. Return the unit to an upright position, plug it in and check the operation of the elevation mechanism. If it's working satisfactorily, unplug the power cord, lower and position the motor shroud and reinsert the plug.

RUNNING BED

The phenolic material laminated running bed surface is coated with a "wax-like" substance. During the break-in period, (20-30 hrs. of operation), this material may "migrate" along the surface of the running bed and accumulate on the head and tail rollers. This accumulation could cause a slight "thumping" noise. If the thumping noise persists after a prolonged period of time, you should remove some of the accumulation from the tail roller. The procedure is as follows:

1. Turn the belt adjustment bolts counter-clockwise with the 1/4" (6.35mm) Hex Key Driver far enough to loosen the running belt.
2. Remove the largest accumulations of the "wax-like" material. **DO NOT** remove all the substance, as it is needed to lubricate the running bed and belt.
3. Turn the belt adjustment bolts clockwise and adjust the belt to ride in the center of the running surface and motor shroud. **DO NOT** over tighten, as this will distort the shape of the running belt.

Designed and manufactured by **UNISEN,INC.**

Copyright © 1987,1989 **UNISEN, INC.** All rights reserved.

| SYMBOL | PART # | DESCRIPTION | QTY. |
|--------|----------|--|------|
| A | 110-0675 | 5/16" x 2.5" – 18 HEX BOLT | 4 |
| B | 120-0480 | 5/16" FLAT WASHER | 4 |
| C | 110-1870 | 5/16" – 18 SELF LOCKING NUT | 4 |
| D | 709-0710 | TR-532 BASE SUPPORT BRACKET SPACER | 4 |
| E | 708-0570 | INSERT SIDE HANDRAIL CONNECTOR BRACKET | 2 |
| F | 110-0510 | 1/4" x 1.5" – 28 HANDRAIL HEX SCREWS | 8 |
| G | 708-0102 | SIDE HANDRAIL (SHORT) | 1 |
| | 714-0035 | SIDE HANDRAIL (LONG) | 1 |
| H | 714-0045 | DISPLAY HANDRAIL | 1 |
| I | | PRE-DRILLED FRAME HOLES. (CUT LEXAN WITH A SHARP KNIFE) | 6 |
| J | 708-0271 | SIDE HANDRAIL SUPPORT BRACKET | 2 |
| | 290-0030 | 5/16" HEX KEY | 1 |
| | 290-0040 | 5/32" HEX KEY | 1 |

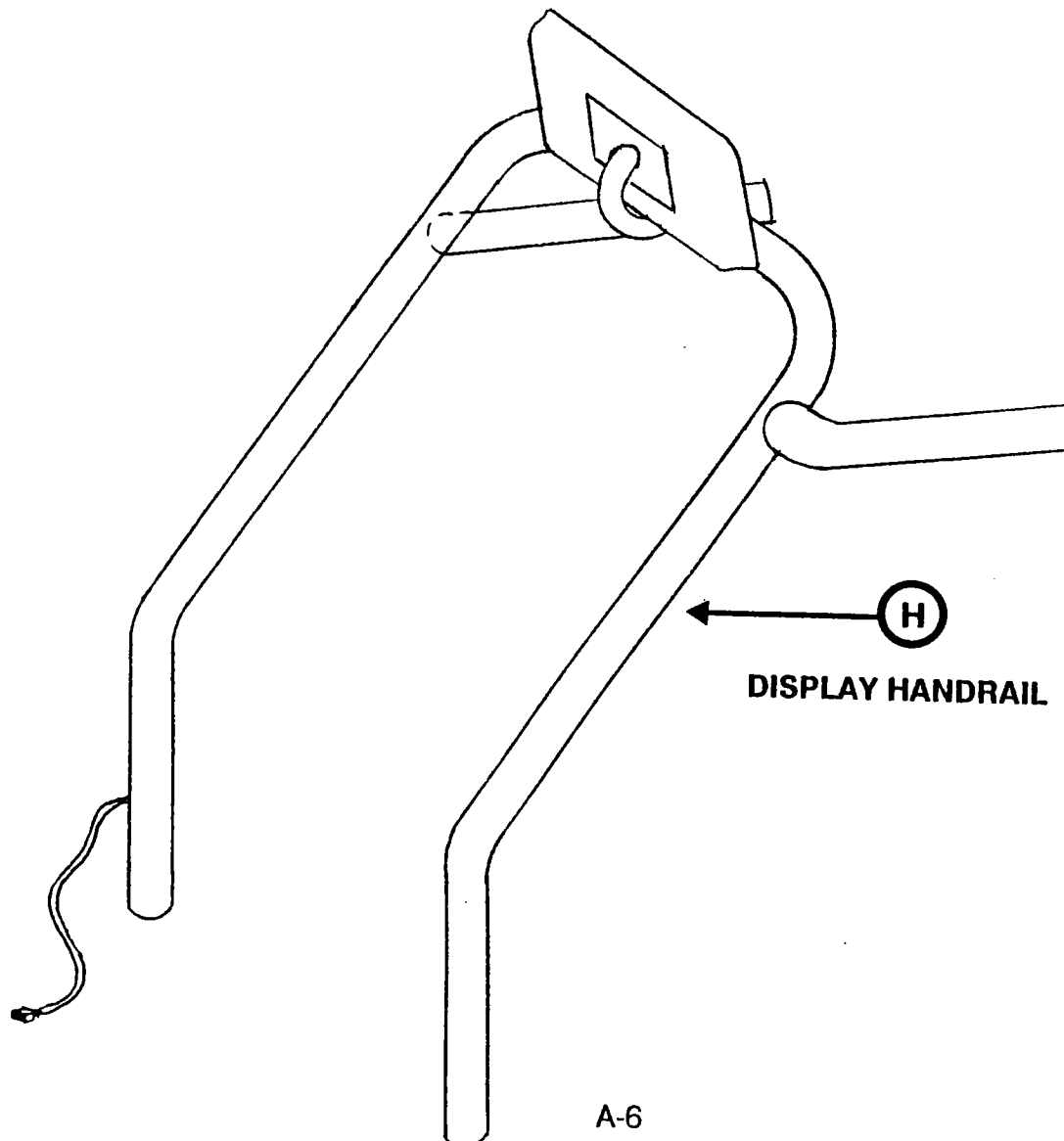

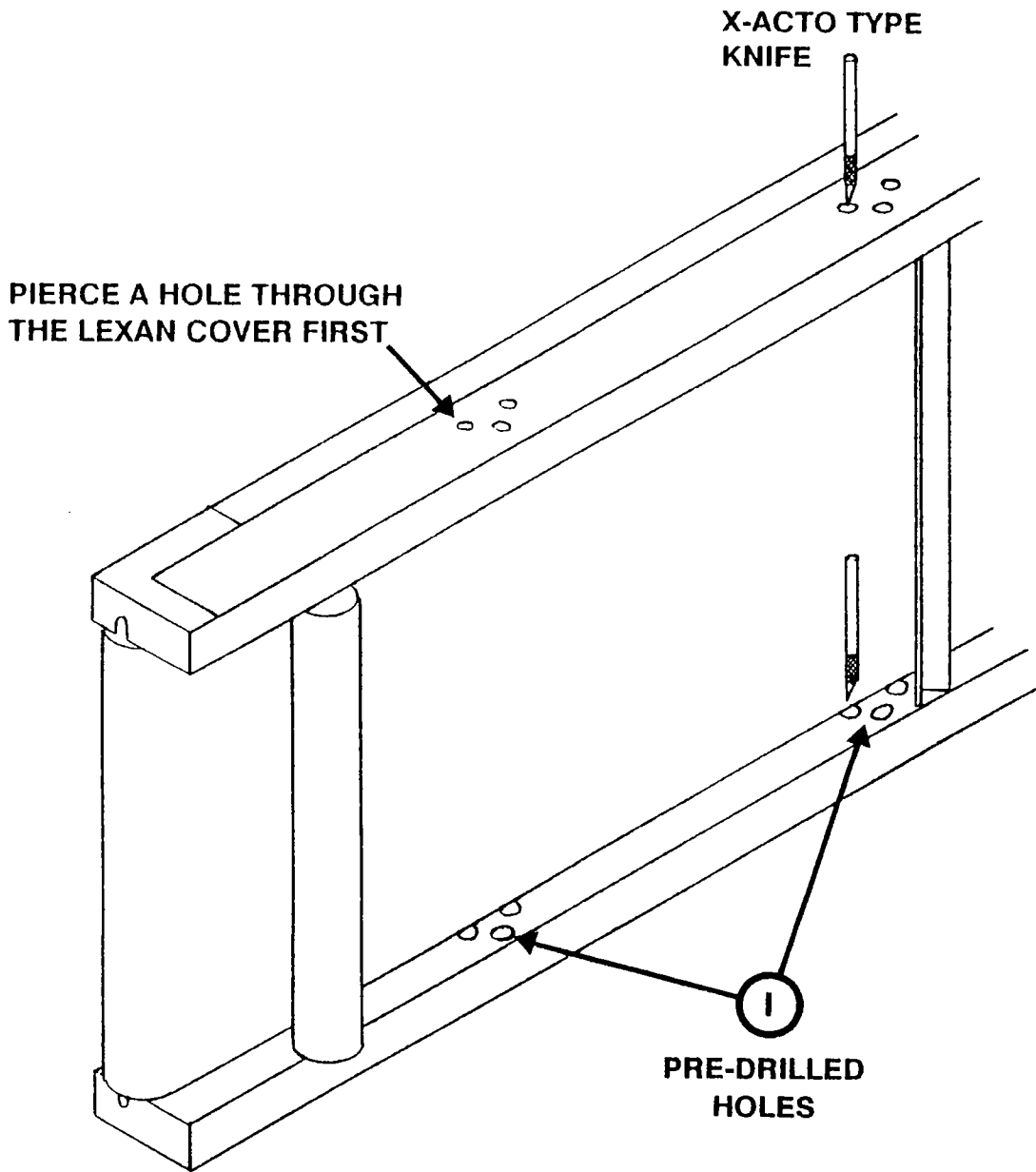

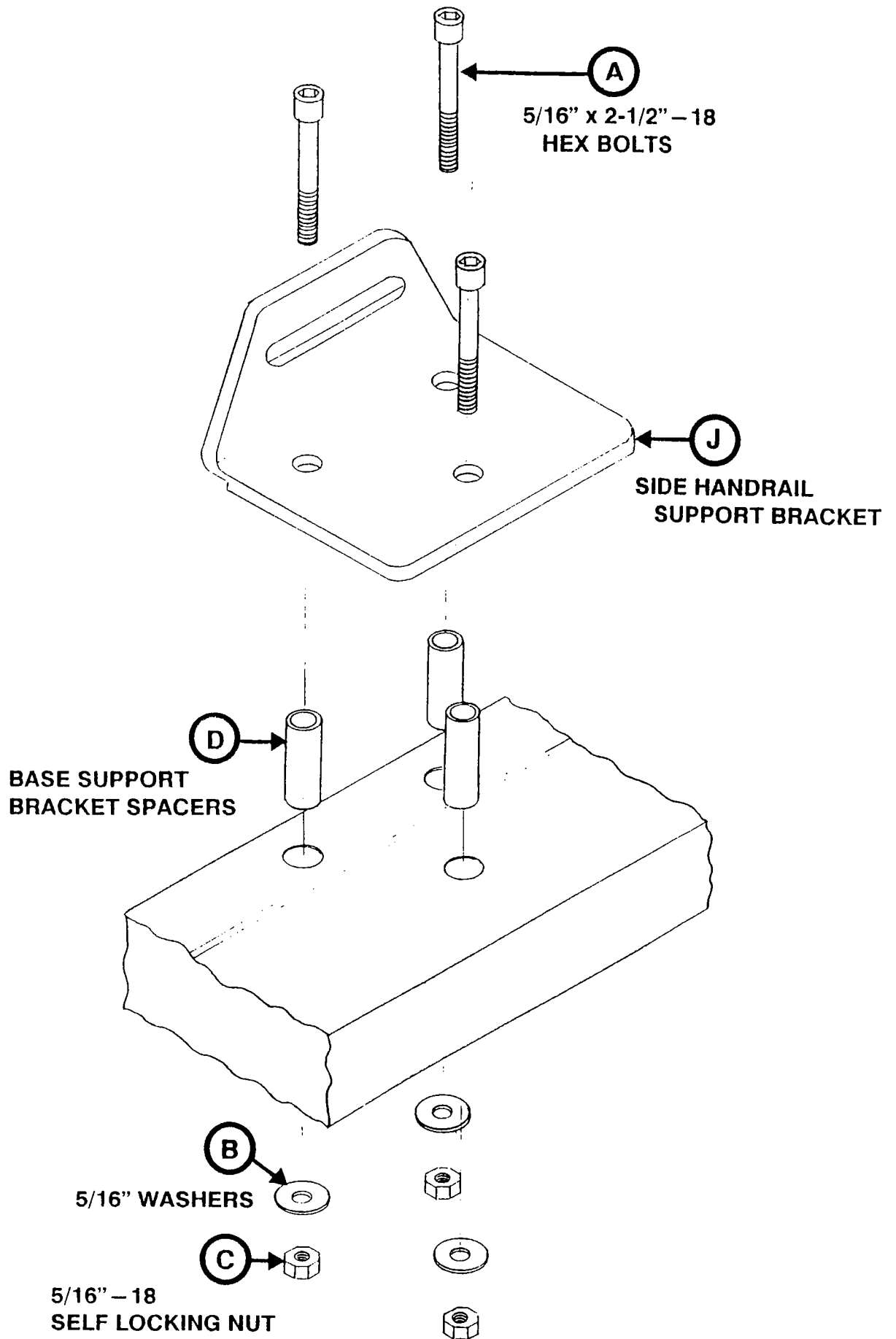

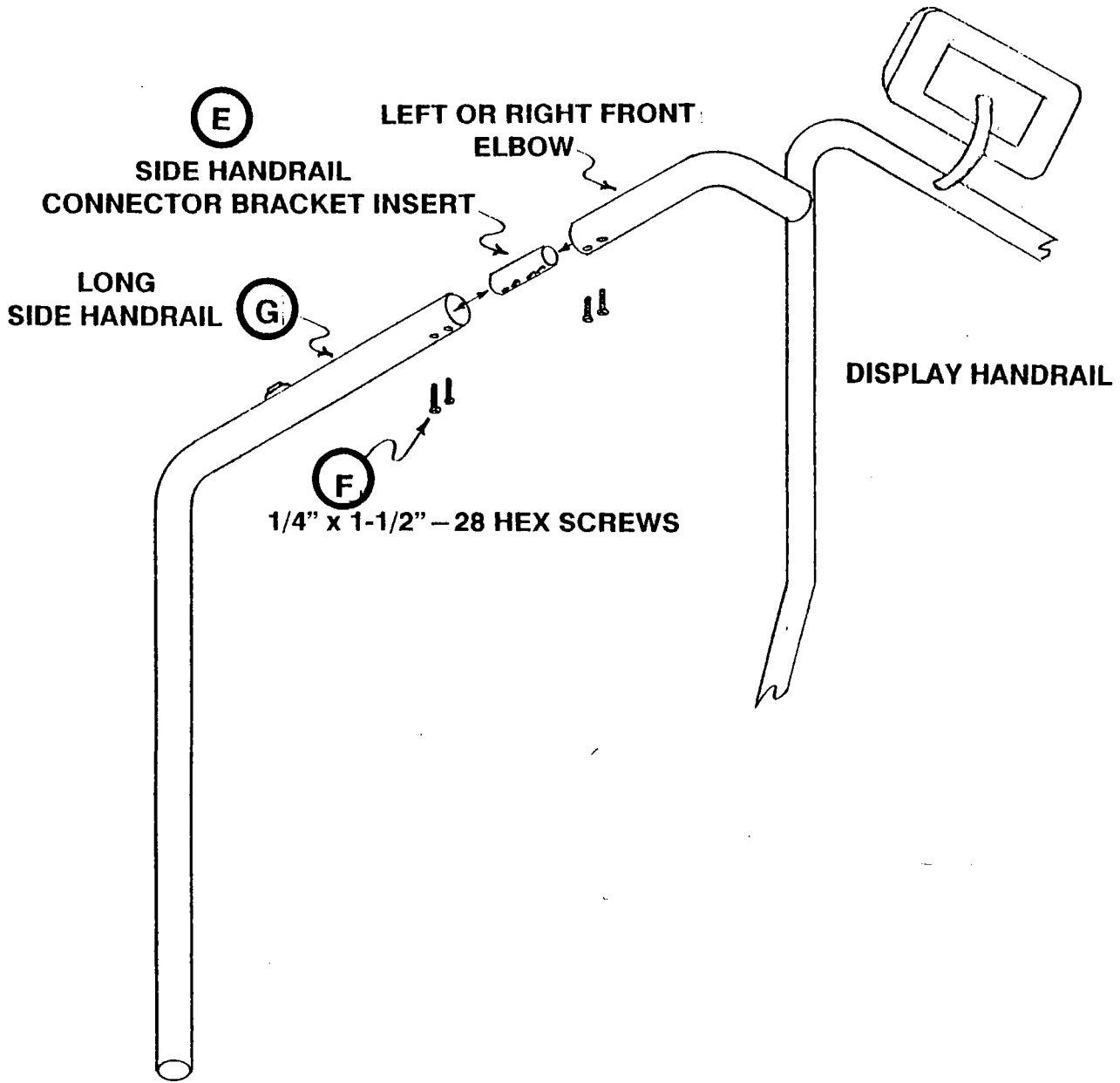

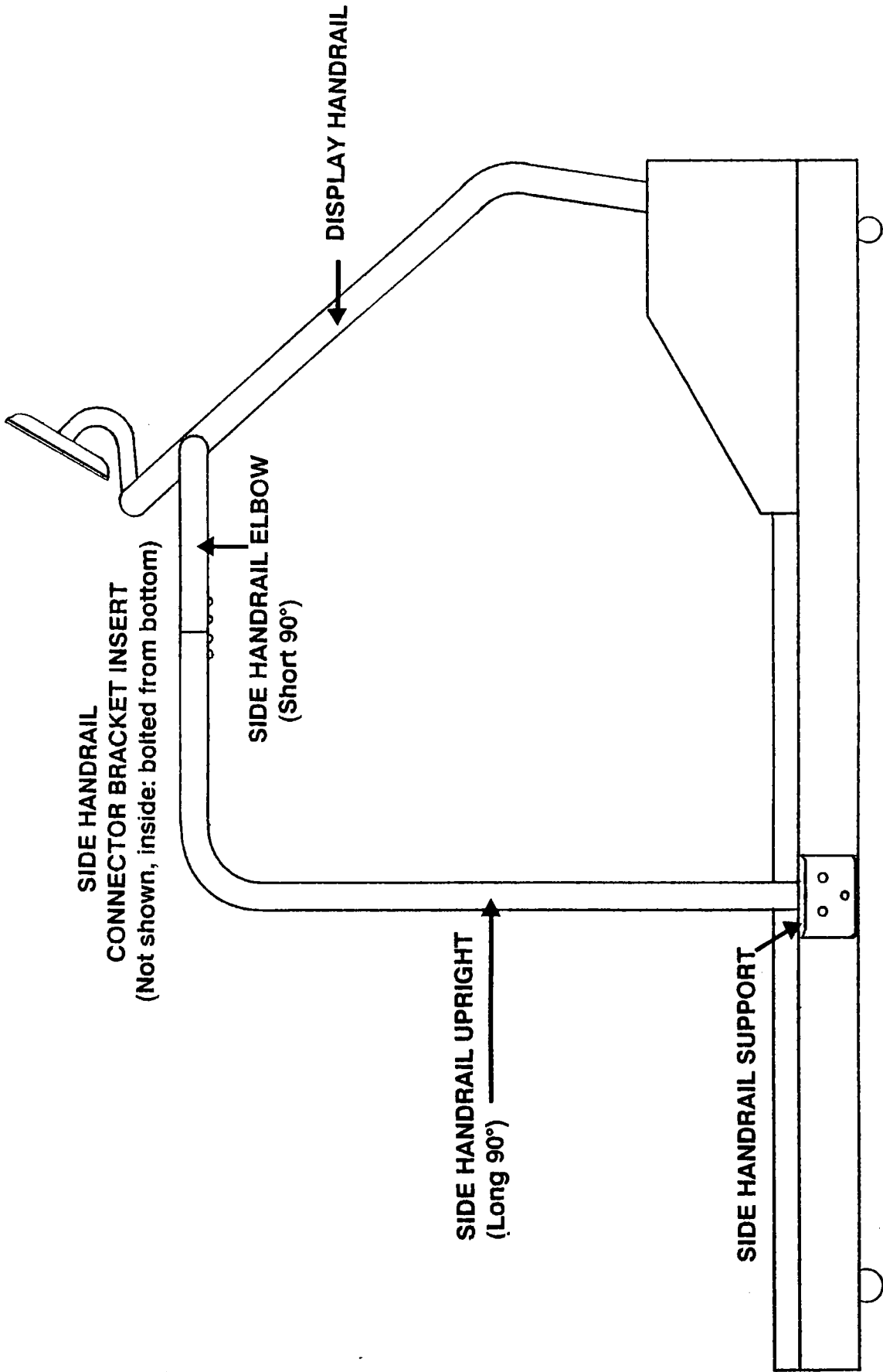

ASSEMBLED HANDRAIL

VOLTAGE COMPENSATION ADJUSTMENT

STARTRACS are all pre-adjusted at the factory to cover a wide range of line voltages. However, there are cases where the incoming power to a facility are out of the voltage compensation range of the **STARTRAC**. If the incoming voltage is too low, a "SPd Error 2" will be displayed. If the voltage is too high, the **STARTRAC** will run faster than 1 MPH (2 km/hr on metric systems) when commanded to minimum speed.

For optimal performance of the **STARTRAC**, check the voltage compensation after initial assembly and whenever the symptoms listed above occur. The procedure is as follows:

- A. Switch off main power.
- B. Enter motor test mode by holding down the **[8]** key while switching on power to the treadmill.

NOTE: With the exception of speed, the displays in motor test mode indicate functions differing from those labeled on the panel.

DO NOT STAND ON THE RUNNING BELT WHEN PERFORMING THE STEPS BELOW:

- C. The center numerical display reflects a speed command value. Initially, this value should be the number 3 (minimum command). The running belt should be at a stop. If not, VR2 on the motor control board must be adjusted (see location diagram). With a small screwdriver, slowly adjust VR2 counter-clockwise just until the belt stops.
- D. Set the command to 18 using the **[FAST]** key to increase (**[SLOW]** to decrease). Verify that the running belt moves at least 1" (25.4 mm) per second. If not, adjust VR2 in the clockwise direction until it does.
- E. Return the command to 3 using the **[SLOW]** key to decrease. If the belt is not at a stop, repeat steps (C) through (E).
- F. Exit motor test mode either pressing the **[STOP]** key or switching main power off.

CO-8
(DISPLAY)

CO-7 (0%)

CO-6 (RPM)

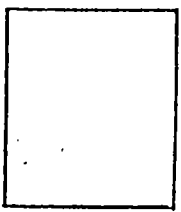
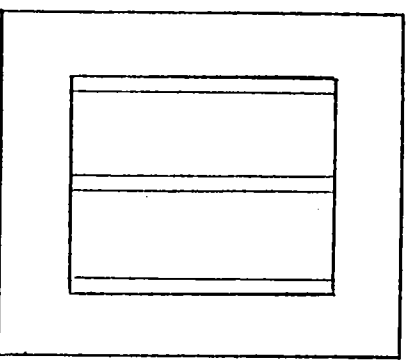
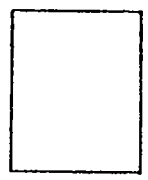
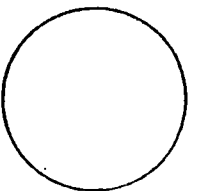
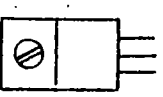
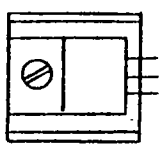

CO-3
ELEV
MOTOR



ELEV
SPEED



TR 411

MOTOR CONTROL
P.C. ASSEMBLY

VR2
RUNNING BELT
THRESHOLD

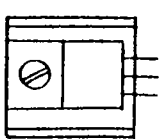

VR4
RAMP DEADBAND

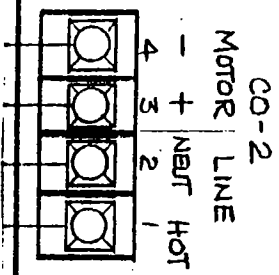
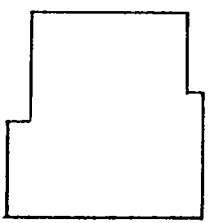

CO-2
MOTOR LINE
HOT
NEUT
LINE

CO-4
LIMIT
SWITCHES

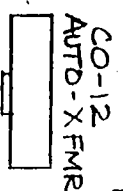

CO-12
AUTO-X FMR

QUICK REFERENCE GUIDE

MANUAL MODE



- ◆スピード、傾斜の設定は手入力で行います。
- ◆99分まで連続走行できます。

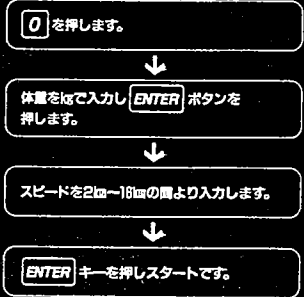

- ◆傾斜をつける場合は ▼ ▲ キーで15段階の設定ができます。
- ◆走行中にスピードを変える場合は **FAST** **SLOW** キーを使い調節します。
- ◆走行を中止するときは **STOP** ボタンを押します。
- ◆**PS/P** のキーでパネルの表示切替ができます。

PROGRAM MODE



- ◆20分間のオートマテックプログラムです。
- ◆自動的に速度、傾斜のコントロールをします。
- ◆正面パネル右側の8パターンのコースから選びます。

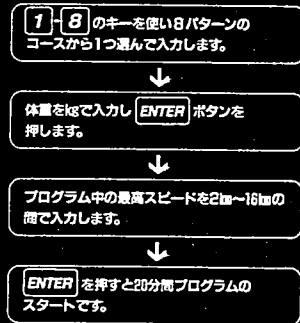

- ◆走行中に最高スピードを変える場合は **FAST** **SLOW** キーを使い調節します。
- ◆走行を中止する場合は **STOP** ボタンを押します。
- ◆**PS/P** のキーでパネルの表示切替ができます。