

# SPORTSART

## 6300/6310 Treadmill Electronics Repair Manual

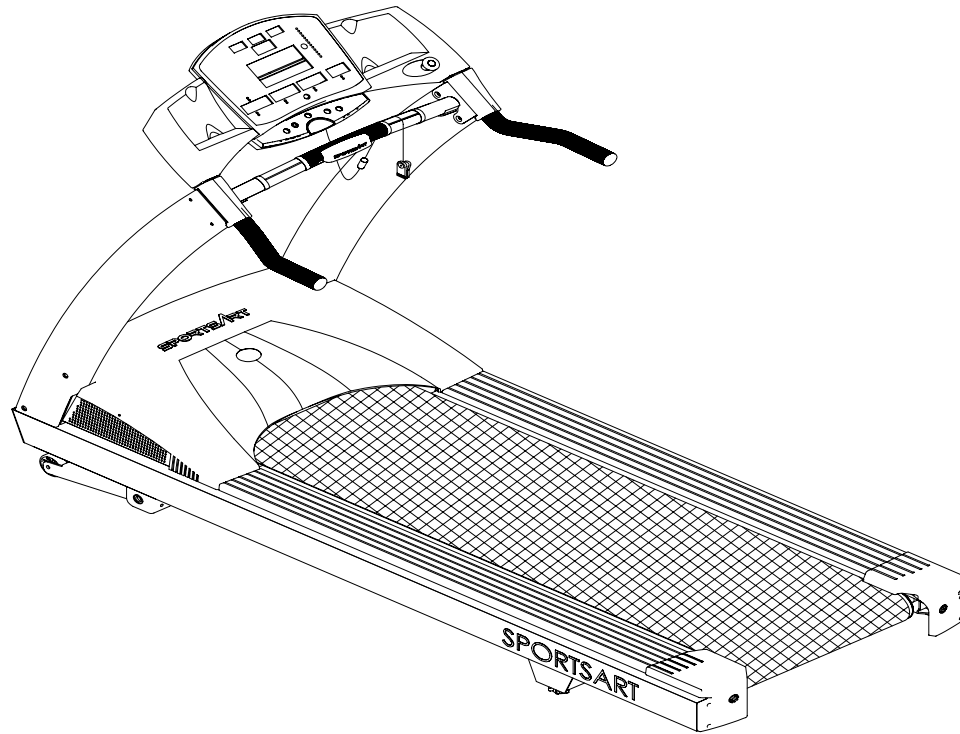

Version 2; Date: 11-11-04

## 6300/6310 Treadmill Electronics Repair Manual

**The 6300/6310 Treadmill Electronics Repair Manual** is designed to be a quick, easy troubleshooting guide for technicians in the field. If you have questions or comments, please write to Bob Baumgartner at [bob@sportsartamerica.com](mailto:bob@sportsartamerica.com).

Version 1 Date: 05-01-03

Version 2 Date: 11-11-04 – Reformatted, corrected, updated for changes to the emergency stop knob and thermal fuse.

# 6300/6310 Treadmill Electronics Repair Manual - Contents

## Contents

### **6300 Introduction – 6300 Treadmill Features**

- 6300 – INTRODUCTION.01 – 6300 Treadmill Specifications at a Glance
- 6300 – INTRODUCTION.02 – 6300 Treadmill Control Area
- 6300 – INTRODUCTION.03 – 6300 Display Windows
- 6300 – INTRODUCTION.04 – 6300 Display Keys
- 6300 – INTRODUCTION.05 – 6300 Display Unit Feedback LEDs
- 6300 – INTRODUCTION.06 – Operating the 6300 Treadmill: Start Up
- 6300 – INTRODUCTION.07 – Operating the 6300 Treadmill: Manual Operation
- 6300 – INTRODUCTION.08 – Operating the 6300 Treadmill: Stop Functions

### **6310 Introduction – 6310 Treadmill Features**

- 6310 – INTRODUCTION.01 – 6310 Treadmill Specifications at a Glance
- 6310 – INTRODUCTION.02 – 6310 Display Windows
- 6310 – INTRODUCTION.03 – 6310 Display Keys
- 6310 – INTRODUCTION.04 – 6310 Display Unit Feedback LED
- 6310 – INTRODUCTION.05 – Operating the 6310 Treadmill: Start Up
- 6310 – INTRODUCTION.06 – Operating the 6310 Treadmill: Manual Operation
- 6310 – INTRODUCTION.07 – Operating the 6310 Treadmill: Stop Functions
- 6310 – INTRODUCTION.08 – Operating the 6310 Treadmill: Programs
- 6310 – INTRODUCTION.09 – Operating the 6310 Treadmill: KPH/MPH, Distance/Time, Clear

## 6300/6310 Treadmill Electronics Repair Manual - Contents

### **Contents (Continued)**

#### **6300/6310 Operation – Explains 6300/6310 Operation in General**

OPERATION.01 – 6300/6310 Power/Signal Diagram

OPERATION.02 – 6300/6310 Power/Signal Flow Explanation

OPERATION.03 – 6300/6310 Motor Compartment Components

#### **6300/6310 Display – Includes 6300/6310 Display Wiring, LEDs, Test Procedures**

DISPLAY.01 – 6300/6310 Display Board Wire Connection Diagram

DISPLAY.02 – 6300/6310 Display Board Wire Connection Picture

DISPLAY.03 – 6300/6310 Display Board LEDs

DISPLAY.04 – 6300/6310 Display VCC Circuit Voltage Test

DISPLAY.05 – 6300/6310 Display VBB Circuit Voltage Test

DISPLAY.06 – 6300/6310 Display Board Main Program IC U5

DISPLAY.07 – 6310 Display Board – Front View

#### **6300/6310 Drive Board – Includes 6300/6310 Drive Board Wiring, LEDs**

DRIVE BOARD.01 – Drive Board Wire Connection Diagram

DRIVE BOARD.02 – 6300/6310 Drive Board Wire Connection Picture

DRIVE BOARD.03 – 6300/6310 Drive Board LEDs – Normally Lit

DRIVE BOARD.04 – 6300/6310 Drive Board LEDs – Normally Not Lit

DRIVE BOARD.05 – 6300/6310 Drive Board Picture

## 6300/6310 Treadmill Electronics Repair Manual - Contents

### **Contents (Continued)**

#### **6300/6310 Drive Motor System Operation**

- MOTOR.01 – 6300/6310 Motor System Operation
- MOTOR.02 – 6300/6310 Voltage to Motor – Test Configuration
- MOTOR.03 – 6300/6310 Voltage to Motor – Test Procedure, Test Results
- MOTOR.04 – 6300/6310 Motor Circuit and OHM Test Configuration, Procedure
- MOTOR.05 – 6300/6310 Transformer Test Configuration
- MOTOR.06 – 6300/6310 Transformer Test Procedure, Results
- MOTOR.07 – 6300/6310 Inductor Test Configuration, Procedure
- MOTOR.08 – 6300/6310 Optic Sensor Signal Test
- MOTOR.09 – 6300/6310 Optic Sensor Signal Test Procedure, Results

#### **6300/6310 Incline System Operation**

- INCLINE.01 – 6300/6310 Incline System Operation
- INCLINE.02 – 6300/6310 Voltage to Incline Motor – Test Configuration
- INCLINE.03 – 6300/6310 Voltage to Incline Test Procedure, Results
- INCLINE.04 – 6300/6310 Incline VR Voltage – Test Configuration
- INCLINE.05 – 6300/6310 Incline VR Voltage Test Procedure, Results

#### **6300/6310 Incline Calibration**

- CALIBRATION.01 – 6300/6310 Incline Calibration Overview
- CALIBRATION.02 – Mechanical Calibration
- CALIBRATION.03 – Electronic Calibration
- CALIBRATION.04 – Incline Calibration Testing

## 6300/6310 Treadmill Electronics Repair Manual - Contents

### **Contents (Continued)**

#### **6300/6310 Heart Rate System**

- HR.01 – Heart Touch Rate (HTR) Operation
- HR.02 – POLAR Heart Rate (HR) Operation
- HR.03 – HTR Board LED Operation, LED Indicator Definitions
- HR.04 – Possible Malfunctions, Troubleshooting
- HR.05 – HTR Cable/Handlebar Test Procedure

#### **6300/6310 Troubleshooting**

- ERR1.01 – ERR 1 – Motor Movement
- ERR1.02 – Troubleshooting: ERR1 Motor Movement
- ERR1.03 – ERR 1 – No Motor Movement
- ERR1.04 – Troubleshooting: ERR1 Motor Movement
- ERR3.01 – ERR 3
- ERR3.02 – ERR 3 Troubleshooting
- ERR7.01 – ERR7
- ERR7.02 – ERR7 Troubleshooting
- NO DISPLAY.01 – Display Does Not Light
- NO DISPLAY.02 – Troubleshooting: Display Does Not Light

## 6300/6310 Treadmill Electronics Repair Manual - Contents

### **Contents (Continued)**

#### **Testing Components Unique to 6300/6310 Treadmills**

FILTER.01 – EMI Filter

FILTER.02 – EMI Filter Test

THERMAL FUSE.01 – Thermal Fuse Placement

THERMAL FUSE.02 – Thermal Fuse Operation

THERMAL FUSE.03 – Thermal Fuse Troubleshooting

EMERGENCY STOP.01 – Emergency Stop Signal Diagram, Emergency Stop Knob Operation

EMERGENCY STOP.02 – Emergency Stop Knob Troubleshooting, Emergency Stop Knob Test Configuration

EMERGENCY STOP.03 – Emergency Stop Revision

KEYS.01 – Key Operation, Key Test Configuration

KEYS.02 – Key Test Procedure

#### **Reference**

REF.01 – 6300/6310 Drive Board LED Reference Chart

REF.02 – 6300/6310 Display LED Reference Chart, 6300/6310 Fuse Reference Chart

REF.03 – VR Voltages for Various SportsArt Treadmill DC Incline Motors

## 6300/6310 Treadmill Electronics Repair Manual – 6300 Introduction

### **6300 Introduction – 6300 Treadmill Features**

- 6300 – INTRODUCTION.01 – 6300 Model Treadmill Specifications at a Glance
- 6300 – INTRODUCTION.02 – 6300 Treadmill Control Area
- 6300 – INTRODUCTION.03 – 6300 Display Windows
- 6300 – INTRODUCTION.04 – 6300 Display Keys
- 6300 – INTRODUCTION.05 – 6300 Display Unit Feedback LEDs
- 6300 – INTRODUCTION.06 – Operating the 6300 Treadmill: Start Up
- 6300 – INTRODUCTION.07 – Operating the 6300 Treadmill: Manual Operation
- 6300 – INTRODUCTION.08 – Operating the 6300 Treadmill: Stop Functions



## 6300/6310 Treadmill Electronics Repair Manual – 6300 Introduction

### 6300 Treadmill Specifications at a Glance

Function	Description
Operation Modes	Originally had only manual mode and no exercise programs. Exercise programs added July 2003. Program time added Jan. 2004
Heart Rate (HR) Function	POLAR transmitter and heart touch rate (HTR) readings
Heart Rate Control (HRC)	Heart rate target values: 65%; 72.5%; 80%, Sept. 2003
Display – 7-Segment Digital	1.Distance / Incline (Board revised Feb. 2003 because incline stuck.) 2.Calories / HR 3.Time / Pace 4.Speed / Mets (Display became C-Safe compatible Dec. 2004)
Display - Keypad	PET touch type, Sept. 2003
Emergency Stop	Emergency stop knob on display (removed Sept. 2004); pause/stop key on keypad
Drive Board	Revised June 2004 (new is V3.2) after motor brush change
Motor Speed	0.1-12.0 MPH (North America standard); 0.2-20.0 KPH (Europe)
Motor Highest Speed	2900 RPM
Motor Horse Power	Originally 3.2 HP; revised to 4.0 Sept. 2003 with ribbed exterior
Motor Thermal Switch	Turns on “Service” indicator if motor gets too hot, Sept. 2003
Incline Range	0-15%
Incline VR Calibration	0% position = 1.20 VDC; measured on VR blue and green wires
MPH in N. America KPH in Europe	MPH determined by the IC chip. MPH =N. American standard; KPH=European standard. Distance units cannot be changed by touching keys
Power Requirements	120 VAC, 20 AMP dedicated
Frame	Incline support added Nov. 2003; Color: Originally gray, became silver Nov. 2004

## 6300/6310 Treadmill Electronics Repair Manual – 6300 Introduction

### 6300 Treadmill Control Area

Note: Picture shows old type HTR grips. As of Sept. 2004, HTR grips had two, rather than four, contact plates.

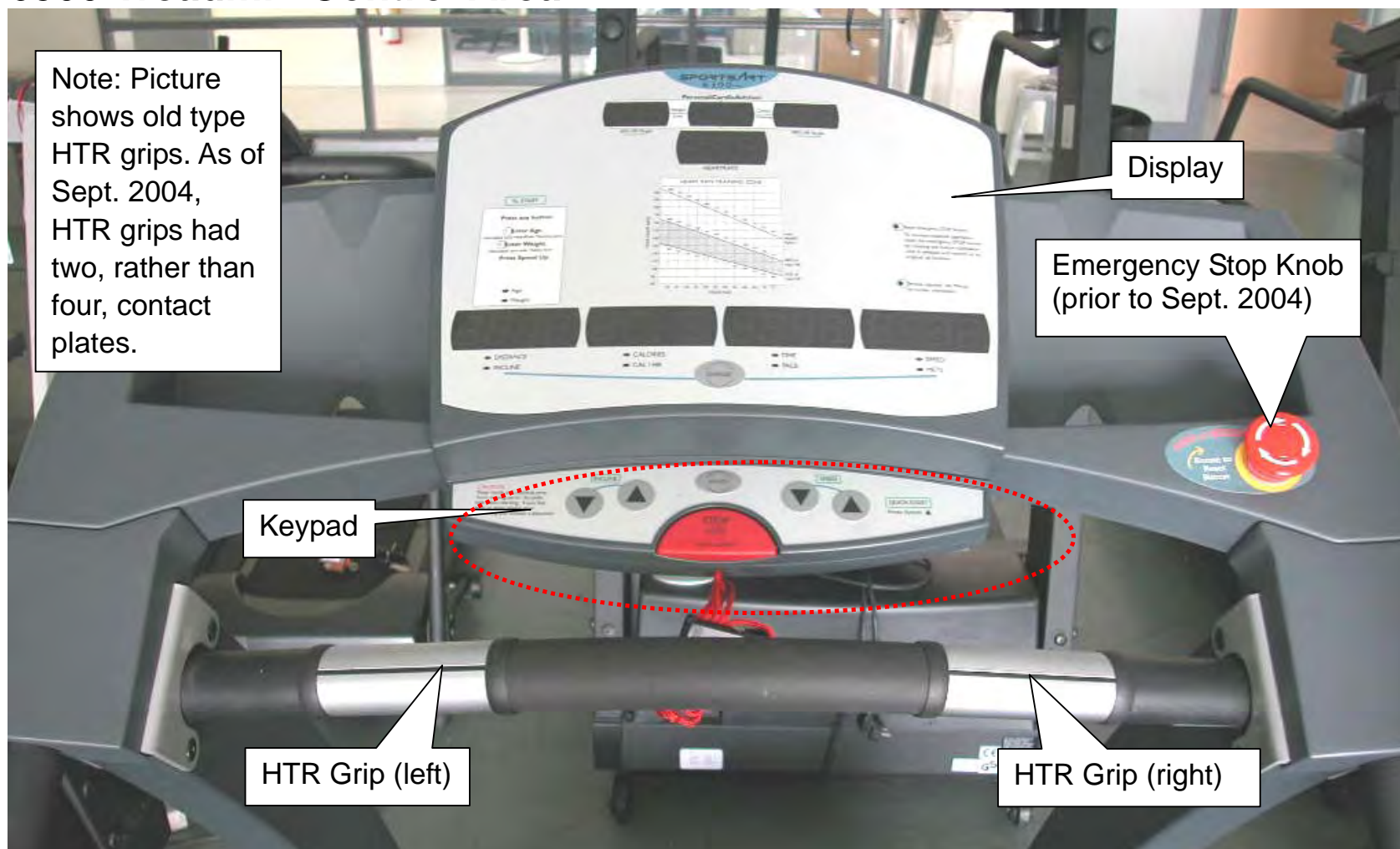

## 6300/6310 Treadmill Electronics Repair Manual – 6300 Introduction

### 6300 Display Windows

65% Target Heart Rate Window  
→ Shows 65% target heart rate

HEART RATE Window  
→ Shows actual heart rate

SPEED & METS Window  
→ SPEED: Shows treadmill speed when indicator is lit.  
→ METS: Shows Metabolic Equivalency Table (METS) when indicator is lit.

80% Target Heart Rate Window  
→ Shows 80% target heart rate

72.5% Target Heart Rate Window  
→ Shows 72.5% target heart

DISTANCE & INCLINE Window  
→ DISTANCE: Shows distance when indicator is lit  
→ INCLINE: Shows incline position when indicator is lit

CALORIES & CAL/HR Window  
→ CALORIES: Shows calorie expenditure when indicator is lit.  
→ CAL/HR: Shows calorie expenditure per hour when indicator is lit.

TIME & PACE Window  
→ TIME: Shows duration of exercise time when indicator is lit.  
→ PACE: Shows minutes per mile when indicator is lit.

## 6300 Display Keys

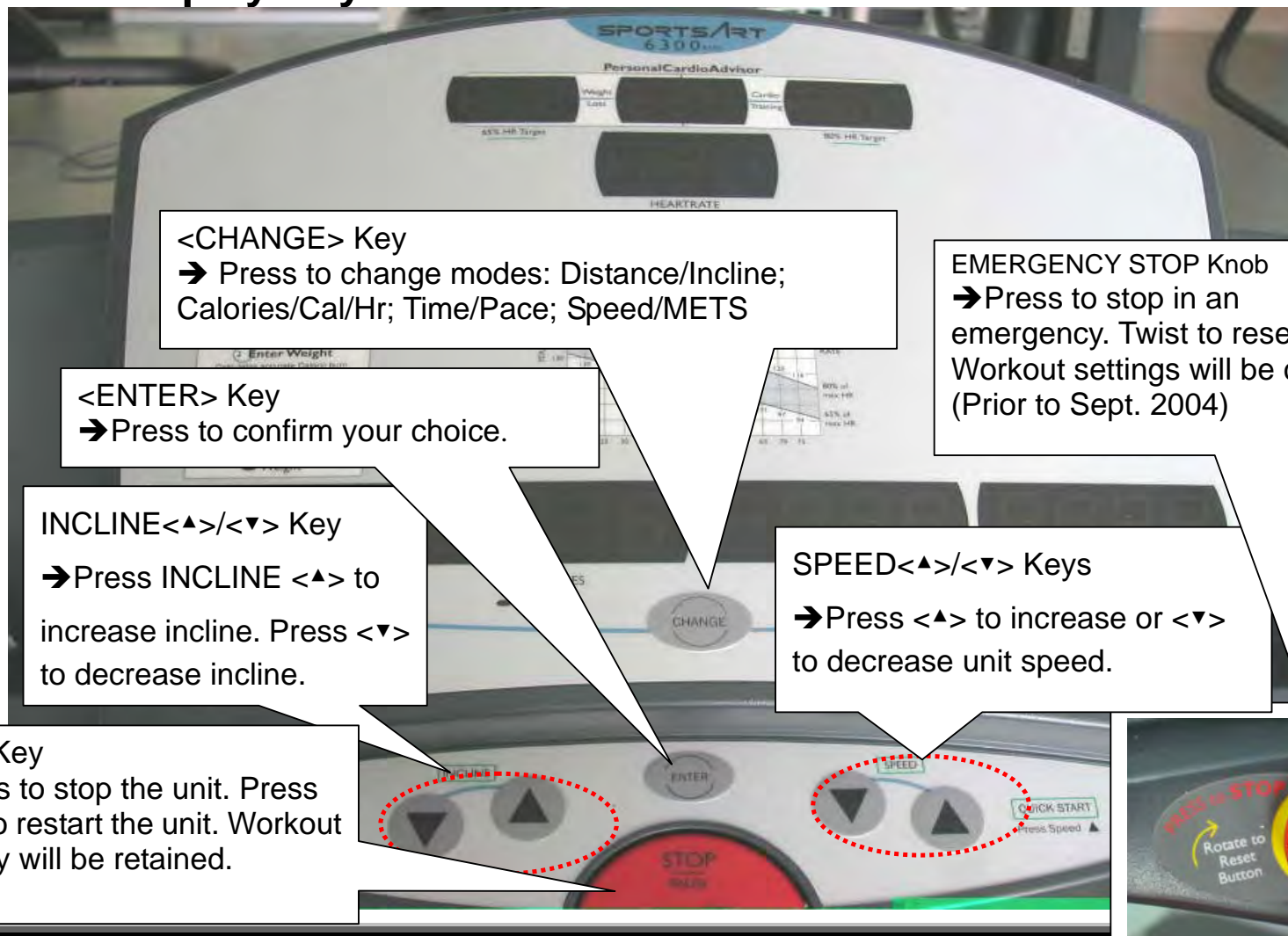

# 6300/6310 Treadmill Electronics Repair Manual – 6300 Introduction

## 6300 Display Unit Feedback LEDs

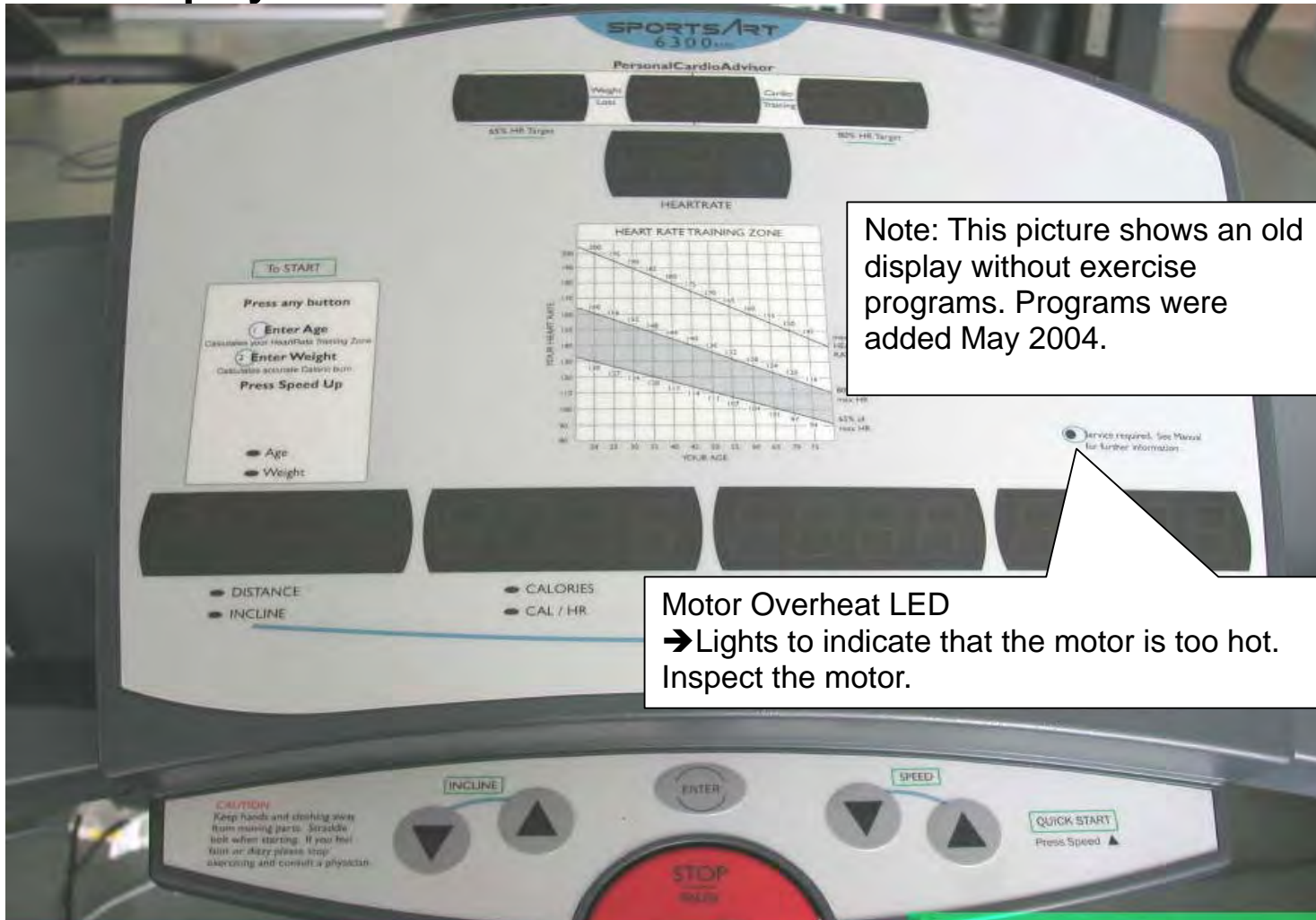

Note: This picture shows an old display without exercise programs. Programs were added May 2004.

Motor Overheat LED  
→ Lights to indicate that the motor is too hot. Inspect the motor.

## Operating the 6300 Treadmill: Start Up

**Quick Start:** Turn on the On/Off switch. On/Off Switch LED lights up. Display lights up. “6300” scrolls across the lower windows. Press Speed <▲> key.

### Start with Personalized Settings

**1. Start Up:** Turn on the On/Off switch. On/Off Switch LED lights up. Display lights up. “6300” scrolls across the lower windows. Press any key except Speed <▲> key.

**2. Age Setting:** Age LED lights up. A number appears in the distance/incline window. Press incline <▲> or <▼> key to change the age setting. Press ENTER key to confirm your choice.

**3. Weight Setting:** Weight LED lights up. A number appears in the distance/incline window. Press incline <▲> or <▼> key to change the weight setting. Press ENTER to confirm your choice.

## 6300/6310 Treadmill Electronics Repair Manual – 6300 Introduction

### **Operating the 6300 Treadmill: Manual Mode**

**Manual Operation:** Manual mode is the default for this product. Manual LED lights up. Press other keys to directly operate the unit.

**Speed:** Press Speed <▲> key to increase speed. Speed window shows increasing speed value. Press Speed <▼> key to decrease speed. Speed window shows decreasing speed value.

Speed measurement units are determined by the IC. Pressing keys will not change MPH to KPH. Speed range: 0.1 to 12.0 MPH (or 0.2-20.0 KPH, European models).

**Incline:** Press INCLINE <▲> key to raise incline. Incline window shows increasing incline values. Incline motor operates up. Press INCLINE <▼> key to lower incline. Incline window shows decreasing incline values.

Incline range: 0-15%.

**Change Key:** Press to change mode window settings. One setting shows distance, calories, time, speed. The other setting shows incline, cal/hr, pace, METs.

## **Operating the 6300 Treadmill: Stop Functions**

### **STOP/PAUSE Key**

Pause function: Press the STOP/Pause key once. Display beeps once. Values such as calories remain on display. SPEED/METS window flashes “0.0”. Press speed up to resume your workout. Display beeps once. Values such as calories are retained.

Clear function: Hold the STOP/Pause key for three seconds. Display beeps once. All values clear. Unit reverts to start up mode. “6300” scrolls across the lower windows.

### **EMERGENCY STOP Knob**

Emergency Stop Function: Press the emergency stop knob. Display beeps once. Emergency stop indicator lights. Lower window shows “----”.

Reset Function: Rotate the emergency stop knob clockwise. Display beeps once. Emergency stop indicator extinguishes. Unit reverts to start up mode. “6300” scrolls across the lower windows.

Note: The emergency stop knob was eliminated Sept. 2004. To update an old unit, eliminating the stop knob, you need two things: A jumper, which goes into the stop knob wire connector on the display, and a plastic sticker, which covers the hole where the stop knob sat.



## 6300/6310 Treadmill Electronics Repair Manual – 6310 Introduction

### **6310 Introduction – 6310 Treadmill Features**

6310 – INTRODUCTION.01 – 6310 Treadmill Specifications at a Glance

6310 – INTRODUCTION.02 – 6310 Display Windows

6310 – INTRODUCTION.03 – 6310 Display Keys

6310 – INTRODUCTION.04 – 6310 Display Unit Feedback LED

6310 – INTRODUCTION.05 – Operating the 6310 Treadmill: Start Up

6310 – INTRODUCTION.06 – Operating the 6310 Treadmill: Manual Operation

6310 – INTRODUCTION.07 – Operating the 6310 Treadmill: Stop Functions

6310 – INTRODUCTION.08 – Operating the 6310 Treadmill: Programs

6310 – INTRODUCTION.09 – Operating the 6310 Treadmill: KPH/MPH, Distance/Time, Clear

## 6300/6310 Treadmill Electronics Repair Manual – 6310 Introduction

### 6310 Treadmill Specifications at a Glance

Function	Description
Operation Modes	Manual; Programs: college track, climber's trek, bay run, river run; Interval 1:1; Interval 1:2. Programs originally had a set 30-minute length; Time settings were added Jan. 2004.
Heart Rate (HR) Function	POLAR transmitter and heart touch rate (HTR)
Heart Rate Control (HRC)	Heart rate target values: 65%; 72.5%; 80%
Display – Dot Matrix	30 x 16 dot
Display - Digital Windows	1.Distance / Incline (Board revised Feb. 2003 because incline stuck.) 2.Calories / HR 3.Time / Pace 4.Speed / Mets (Display became C-Safe compatible Dec. 2004)
Display - Keypad	PET touch type, Sept. 2003
Emergency Stop	Emergency stop knob on display (removed Sept. 2004); pause/stop key on keypad
Drive Board	Revised June 2004 (new is V3.2) after motor brush change
Motor Speed	0.1-12.0 MPH (North America standard); 0.2-20.0 KPH (Europe)
Motor Highest Speed	2900 RPM
Motor Horse Power	Originally 3.2 HP; revised to 4.0 Sept. 2003 with ribbed exterior
Motor Thermal Switch	Turns on "Service" indicator if motor gets too hot (Sept. 2003)
Incline Range	0-15%
Incline VR Calibration	0% position = 1.20 VDC; measured on VR blue and green wires
Units: MPH/KPH	Can be set by key sequence: See 6310 INTRO.08.
Power Requirements	120 VAC, 20 AMP dedicated (Europe: 220 VAC)
Frame	Color: Originally gray, became silver Nov. 2004

# 6300/6310 Treadmill Electronics Repair Manual – 6310 Introduction

## 6310 Display Windows

65% Target Heart Rate Window  
→ Shows 65% target heart rate

HEART RATE Window  
→ Shows actual heart rate

Dot Matrix "Main" Window  
→ Shows scrolling messages

DISTANCE & INCLINE Window  
→ DISTANCE: Shows distance when indicator is lit.  
→ INCLINE: Shows incline position when indicator is lit.

CALORIES & CAL/HR Window  
→ CALORIES: Shows calorie expenditure when indicator is lit.  
→ CAL/HR: Shows calories per hour when indicator is lit.

80% Target Heart Rate Window  
→ Shows 80% target heart rate

72.5% Target Heart Rate Window  
→ Shows 72.5% target heart rate

SPEED & METS Window  
→ SPEED: Shows speed when indicator is lit.  
→ METS: Shows Metabolic Equivalency Table (METS) when

TIME & PACE Window  
→ TIME: Shows duration of exercise time when indicator is lit.  
→ PACE: Shows minutes per mile or kilometer when indicator is lit.

# 6300/6310 Treadmill Electronics Repair Manual – 6310 Introduction

## 6310 Display Keys

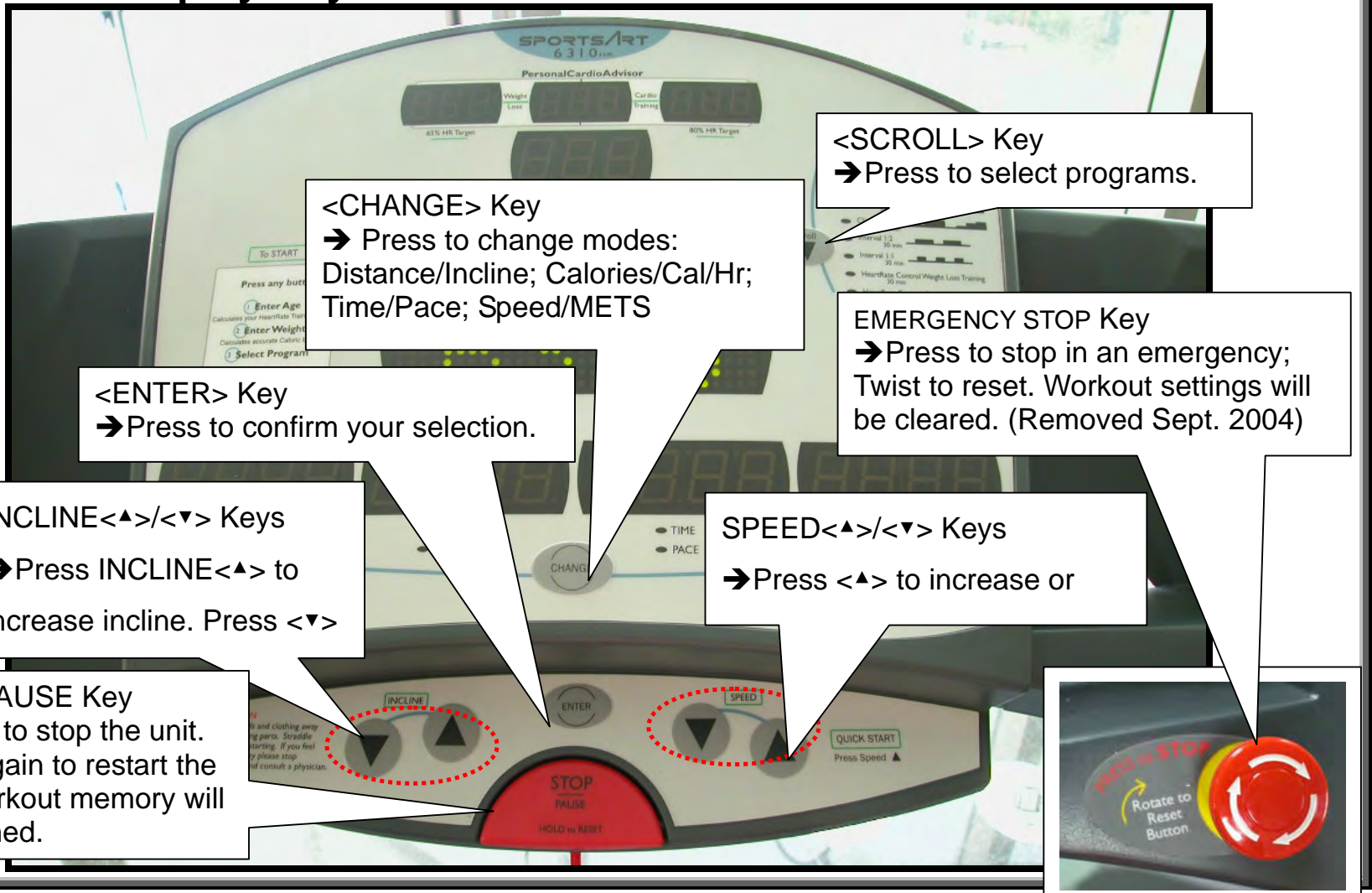

# 6300/6310 Treadmill Electronics Repair Manual – 6310 Introduction

## 6310 Display Unit Feedback LED

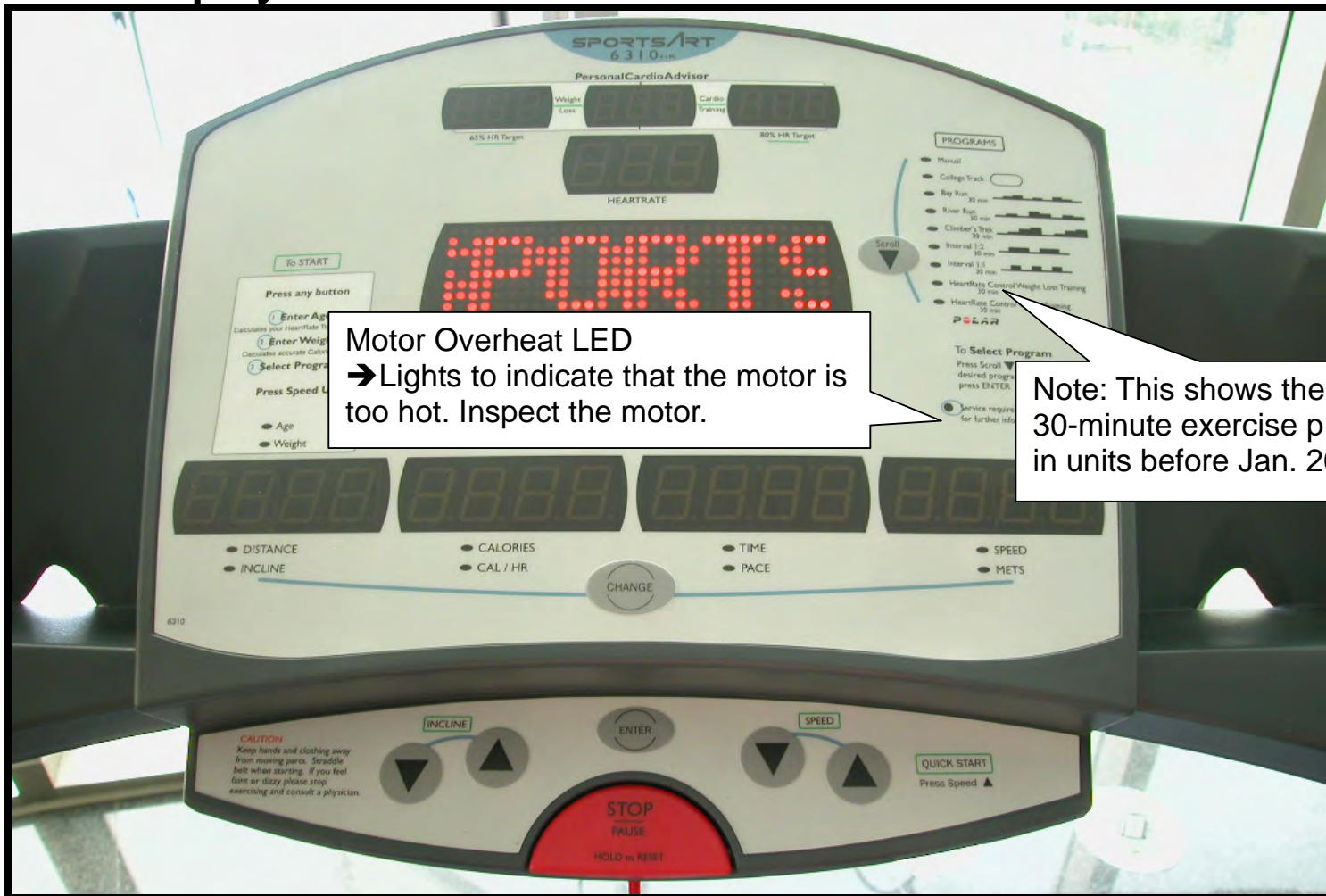

Motor Overheat LED  
→ Lights to indicate that the motor is too hot. Inspect the motor.

Note: This shows the old, 30-minute exercise programs in units before Jan. 2004.

## Operating the 6310 Treadmill: Start Up

**Quick Start:** Turn on the On/Off switch. On/Off Switch LED lights up. Display lights up. “SPORTSART” scrolls across the top of the main window. “6310” appears in the lower part of the main window. Press SPEED <▲> key.

### Start Up with Personalized Settings

**1. Start Up:** Turn on the On/Off switch. On/Off Switch LED lights up. Display lights up. “SPORTSART” scrolls across the top of the main window. “6310” appears in the lower part of the main window. Press any key except SPEED up.

**2. Age Setting:** Age LED lights. “PRESS INCLINE ▲▼ TO INPUT YOUR AGE, PRESS ENTER...” scrolls across the top of the main window. “AGE” appears in the lower part of the main window. Press incline <▲> or <▼> key to set age. Press ENTER key to confirm your choice.

**3. Weight Setting:** Weight LED lights. “PRESS INCLINE TO INPUT YOUR WEIGHT, PRESS ENTER...” scrolls across the top of the main window. “LB” or “KG” appears in the lower part of the main window. A number appears in the distance/incline window. Press incline <▲> or <▼> key to change the weight setting. Press ENTER key to confirm your choice.

**4. Manual Operation:** “PRESS SPEED <▲>” scrolls across the main window. The SPEED LED lights. “0.0” flashes in the SPEED/METS window. In the program area, the MANUAL indicator lights. Press SPEED<▲> key. Treadmill walk belt starts moving.

## Operating the 6310 Treadmill: Manual Operation

To enter manual mode, press the SCROLL key until the MANUAL indicator lights. Manual mode provides direct control over speed, incline, and other functions.

**Speed:** Press Speed <▲> key to increase speed. Speed window shows increasing speed value.

Press Speed <▼> key to decrease speed. Speed window shows decreasing speed value.

Speed measurement units are determined by the IC. Pressing keys will not change MPH to KPH. Speed range: 0.1 to 12.0 MPH (or 0.2-20.0 KPH, European models).

**Incline:** Press INCLINE <▲> key to raise incline. Incline window shows increasing incline values. Incline motor operates up. Press INCLINE <▼> key to lower incline. Incline window shows decreasing incline values.

Incline range: 0-15%.

**Change Key:** Press to change mode window settings. One setting shows distance, calories, time, speed. The other setting shows incline, cal/hr, pace, METs.

## **Operating the 6310 Treadmill: Stop Functions**

### **STOP/PAUSE Key**

Pause function: Press the STOP/Pause key once. Display beeps once. Workout memory values, such as calorie expenditure, remain on display. SPEED indicator lights. SPEED/METS window flashes “0.0”. Press speed up to resume your workout. Display beeps once. Workout memory, including calorie expenditure, etc., is retained.

Clear function: Hold the STOP/Pause key for three seconds. Display beeps once. All values clear. Unit reverts to start up mode. “SPORTSART” scrolls across the upper part of the main window. “6310” appears in the lower part of the main window.

### **Emergency Stop Knob**

Emergency Stop Function: Press the emergency stop knob. Display beeps once. All values clear. All functions stop. “RESET EMERGENCY STOP BUTTON” scrolls across main window.

Reset Function: Rotate the emergency stop knob clockwise. Display beeps once. Unit reverts to start up mode. “SPORTSART” scrolls across the upper part of the main window. “6310” appears in the lower part of the main window.

Note: The emergency stop knob was eliminated Sept. 2004. To update an old unit, eliminating the stop knob, you need two things: A jumper, which goes into the stop knob wire connector on the display, and a plastic sticker, which covers the hole where the stop knob sat.



## 6300/6310 Treadmill Electronics Repair Manual – 6310 Introduction

### Operating the 6310 Treadmill: Programs

Press the Scroll<▼> key to select programs. A program indicator lights. The next program indicator down lights each time the scroll key is pressed. Press the ENTER key to confirm your choice. Then press the SPEED <▲> key. The incline position appears graphically on the main window. Secondary windows show workout values.

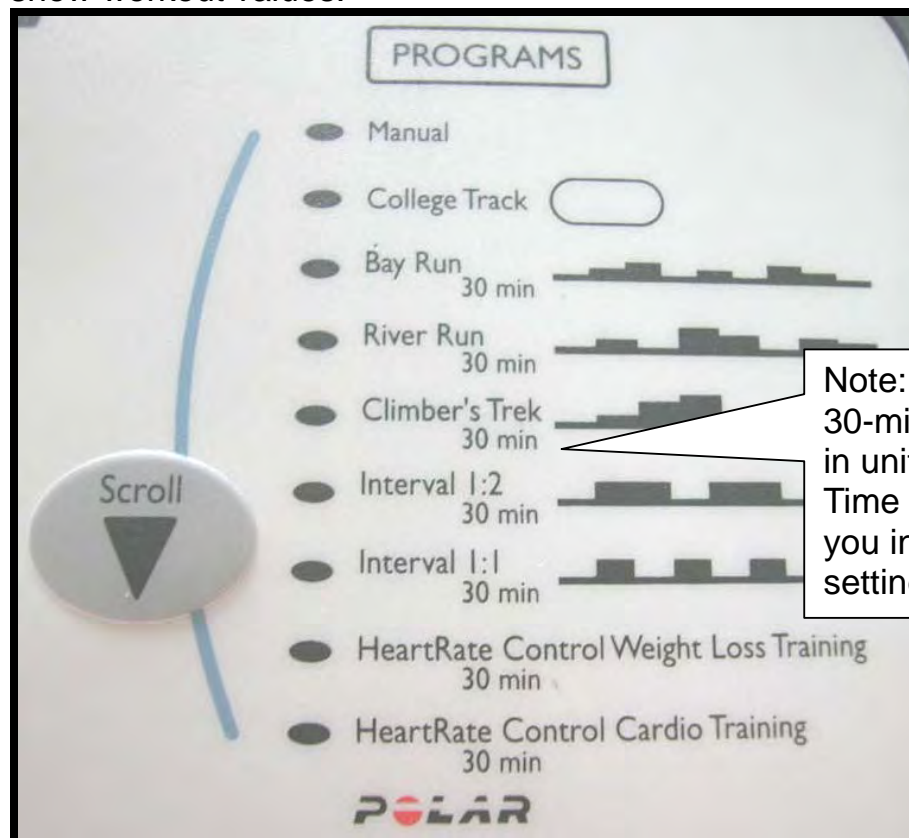

Note: This shows the old, 30-minute exercise programs in units before Jan. 2004. Time can now be set when you input the program settings.

## 6300/6310 Treadmill Electronics Repair Manual – 6310 Introduction

### **KPH/MPH, Distance/Time, Clear**

**Set MPH/KPH:** Turn on the unit. “SPORTSART” scrolls across the main window. “6310” appears in the lower part of the main window. Hold the CHANGE key down three seconds. “PRESS TO SELECT MPH/KPH, PRESS ENTER” scrolls across the top part of the main window. “MPH” or “KPH” appears on the lower part of the main window. Press <▲> and <▼> keys to toggle between MPH and KPH. When your choice appears, press the ENTER key to confirm your selection.

**See Distance/Time:** “PRESS ▲▼ TO SELECT MODIFY HRC TARGET HR (Y/N)?, PRESS ENTER” scrolls across the top part of the main window. “NO” or “YES” appears on the lower part of the main window. Press <▲> and <▼> keys to toggle between “no” and “yes”. Select your choice. Press ENTER key to continue.

**Distance:** A four-digit number appears over the word “MILE” (KM if in metric mode). “TOTAL DISTANCE” scrolls across the main window. This is the distance of unit operation. Press ENTER key to continue.

**Time:** A four-digit number appears over the word HOUR. “TOTAL TIME” scrolls across the main window. This is the total time of unit operation. Press ENTER key to continue.

**Start Up:** Unit enters start up mode. “SPORTSART” scrolls across the top part of the main window. “6310” appears in the lower part of the main window.

**To Clear Time/Distance:** In start up mode, press STOP/PAUSE and ENTER keys for one second. “PRESS ▲▼ TO SELECT CLEAR TOTAL DISTANCE & TIME (Y/N)?, PRESS ENTER” scrolls across the top of the main screen. “NO” or “YES” appears on the bottom of the main screen. Press <▲> <▼> keys to select “YES” to delete the time and distance or select “NO” to preserve the present distance/time memory. Press ENTER key to confirm your choice.

## 6300/6310 Treadmill Electronics Repair Manual - Operation

### **6300/6310 Operation – Explains 6300/6310 Operation in General**

OPERATION.01 – 6300/6310 Power/Signal Diagram

OPERATION.02 – 6300/6310 Power/Signal Flow Explanation

OPERATION.03 – 6300/6310 Motor Compartment Components

# 6300/6310 Treadmill Electronics Repair Manual – Operation

## 6300/6310 Power/Signal Diagram

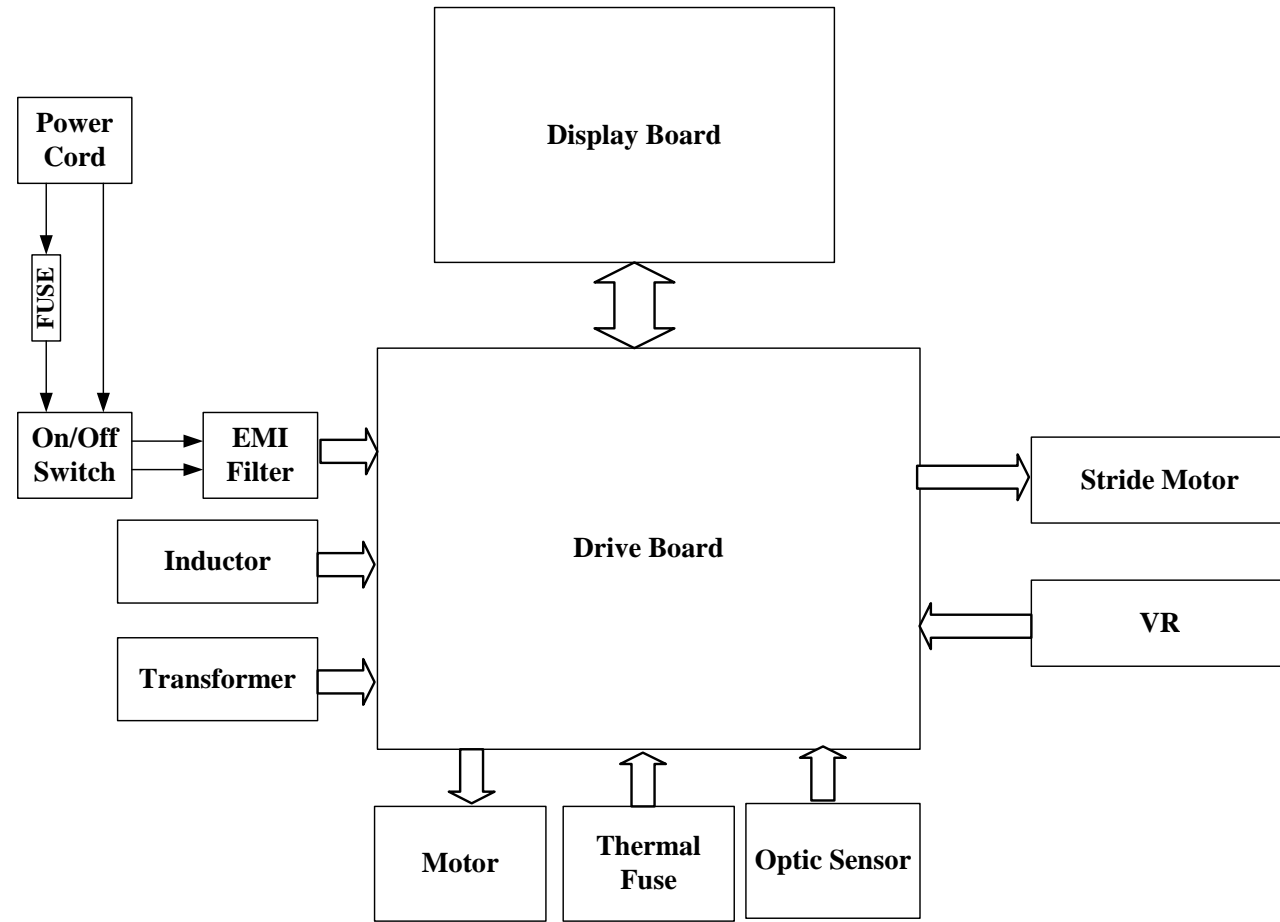

## 6300/6310 Treadmill Electronics Repair Manual – Operation

### **6300/6310 Power/Signal Flow Explanation**

1. AC voltage travels through the power cord, fuse, on/off switch, EMI filter, into the drive board.
2. AC voltage travels from the drive board to the transformer. The transformer outputs lower levels of AC voltage.
3. The drive board processes the AC voltage into DC voltage for use by the display, drive motor, and incline motor.
4. When the user presses a key, a signal travels from the keypad to the main program in the display, where it is processed.
5. The display board sends a command via the ribbon cable to the drive board.
6. The drive board provides DC voltage to motors as directed by the display. For example, when you press the Speed Up key, the signal travels from the display to the drive board via the ribbon cable; the drive board emits voltage for drive motor operation. Similarly, when you press the Incline Up key, the drive board emits voltage for incline motor operation.
7. On both the drive motor and incline motor are sensors which tell the display about motor operation. Their signals travel to the drive board, up the ribbon cable, to the display.
8. On the drive motor is an optic sensor. As the drive motor rotates, the optic sensor wheel rotates. The sensor detects the difference between optic wheel teeth and spaces, thus indicating speed.
9. On the incline motor is a variable resistor (VR). As the incline motor turns, the VR turns, and its output voltage changes, thus indicating the incline position.
10. The display uses sensor signals to determine whether to command the drive board to continue providing or shut off power to the motors.

### **The Role of Other Parts**

1. The inductor ensures steady current to the drive motor.
2. The thermal fuse on the drive motor is activated if the motor becomes too hot. When the thermal fuse is activated (the circuit stops conducting), the “service required” indicator on the display lights.
3. The Electro Magnetic Irradiation (EMI) filter prevents interference to other products.

## 6300/6310 Motor Compartment Components

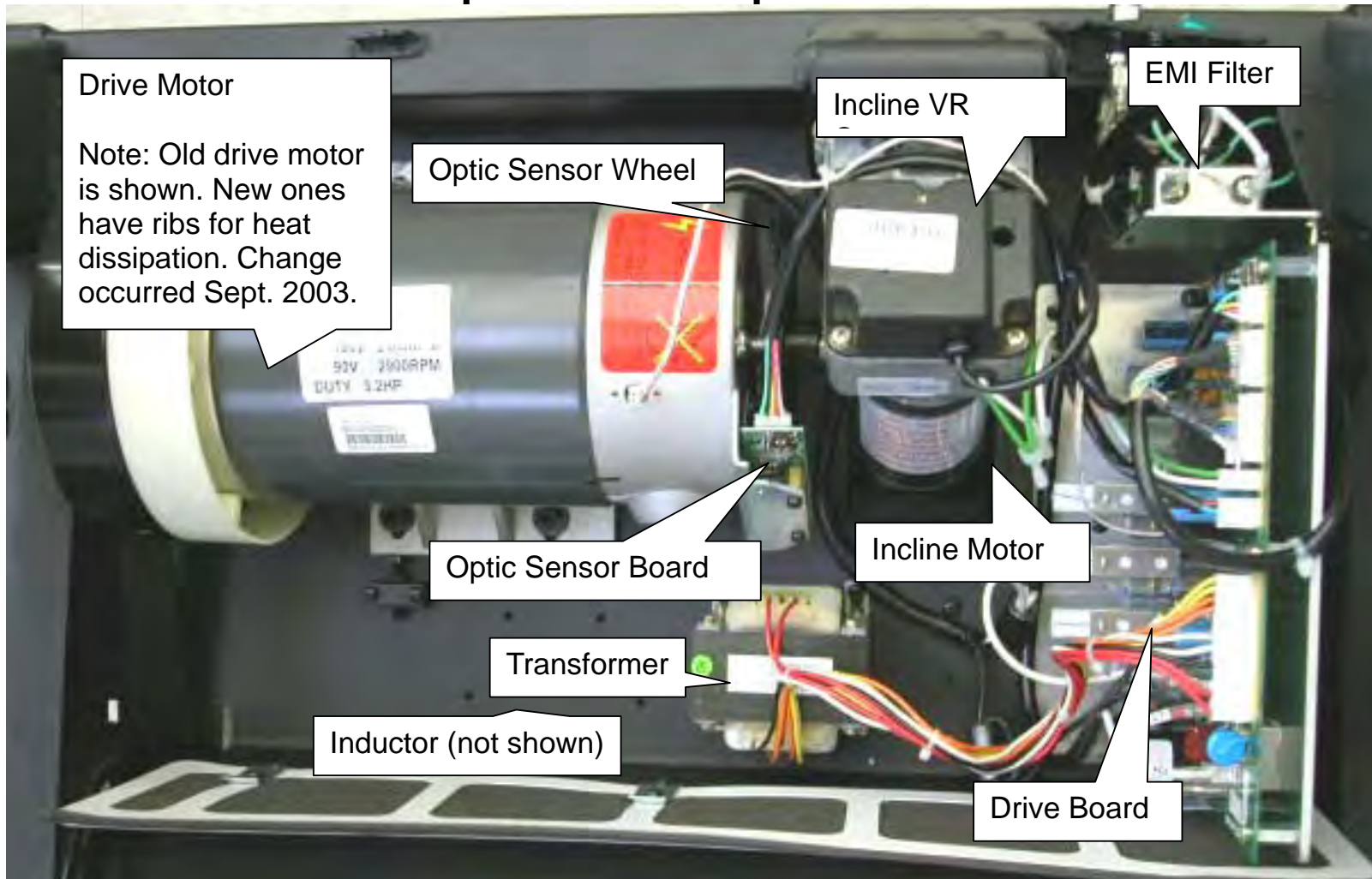

## 6300/6310 Treadmill Electronics Repair Manual – Display

### **Display – Includes 6300/6310 Display Wiring, LEDs, Test Procedures**

DISPLAY.01 – 6300/6310 Display Board Wire Connection Diagram

DISPLAY.02 – 6300/6310 Display Board Wire Connection Picture

DISPLAY.03 – 6300/6310 Display Board LEDs

DISPLAY.04 – 6300/6310 Display VCC Circuit Voltage Test

DISPLAY.05 – 6300/6310 Display VBB Circuit Voltage Test

DISPLAY.06 – Display Board Main Program IC U5

DISPLAY.07 – 6310 Display Board – Front View

# 6300/6310 Treadmill Electronics Repair Manual – Display

## 6300/6310 Display Board Wire Connection Diagram

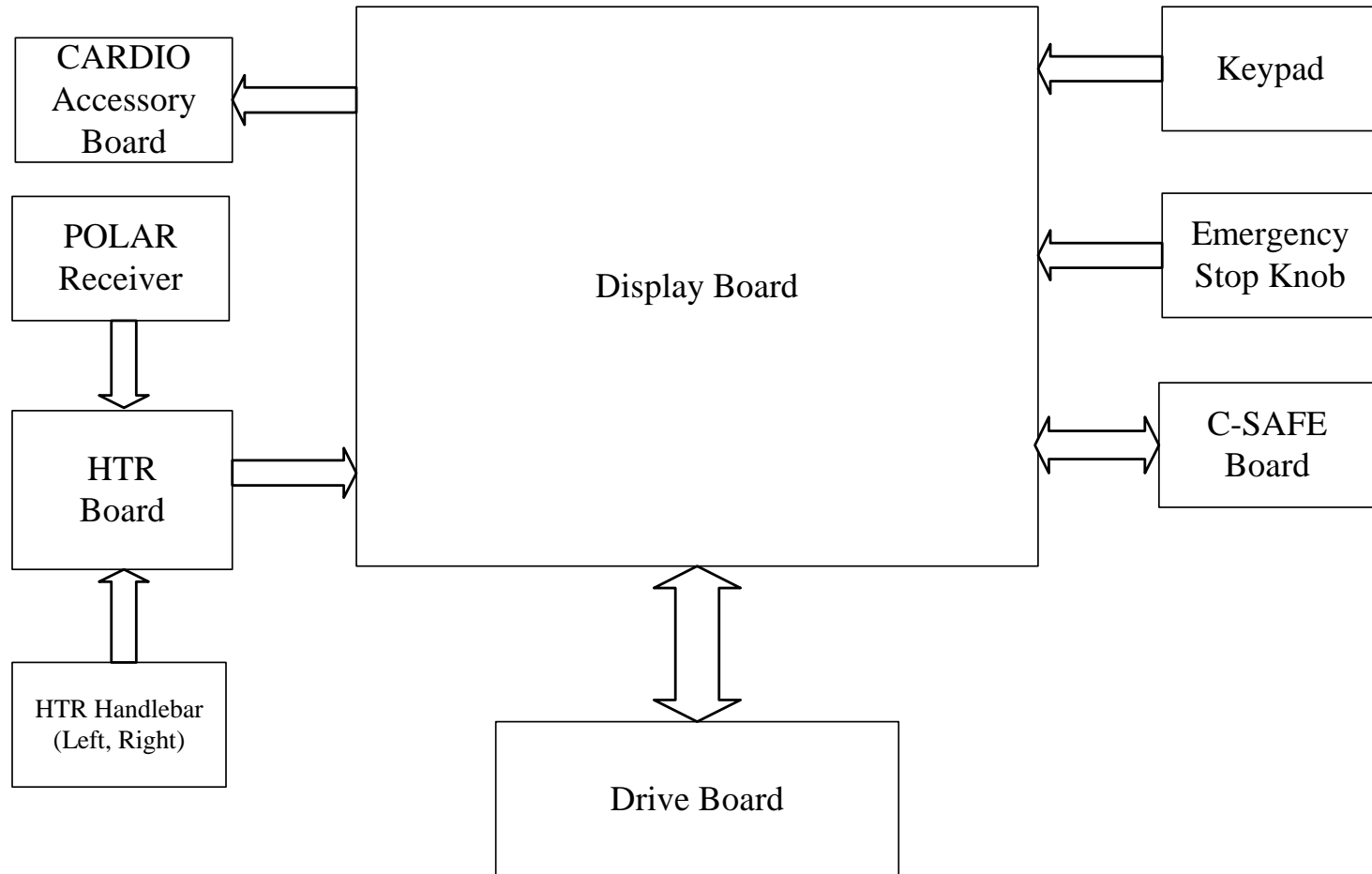



## 6300/6310 Treadmill Electronics Repair Manual – Display

### 6300/6310 Display Board Wire Connection Picture

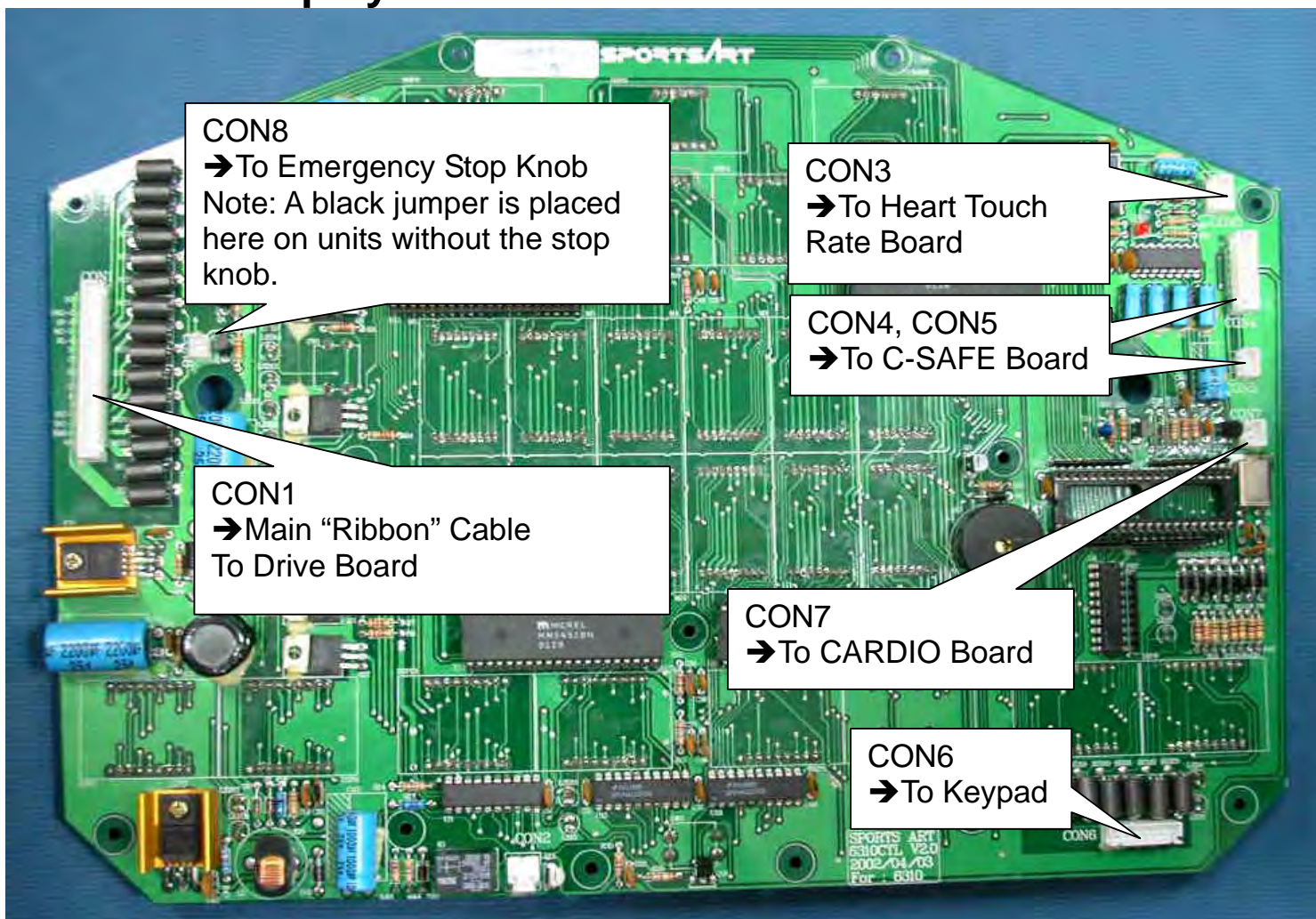

## 6300/6310 Display Board LEDs

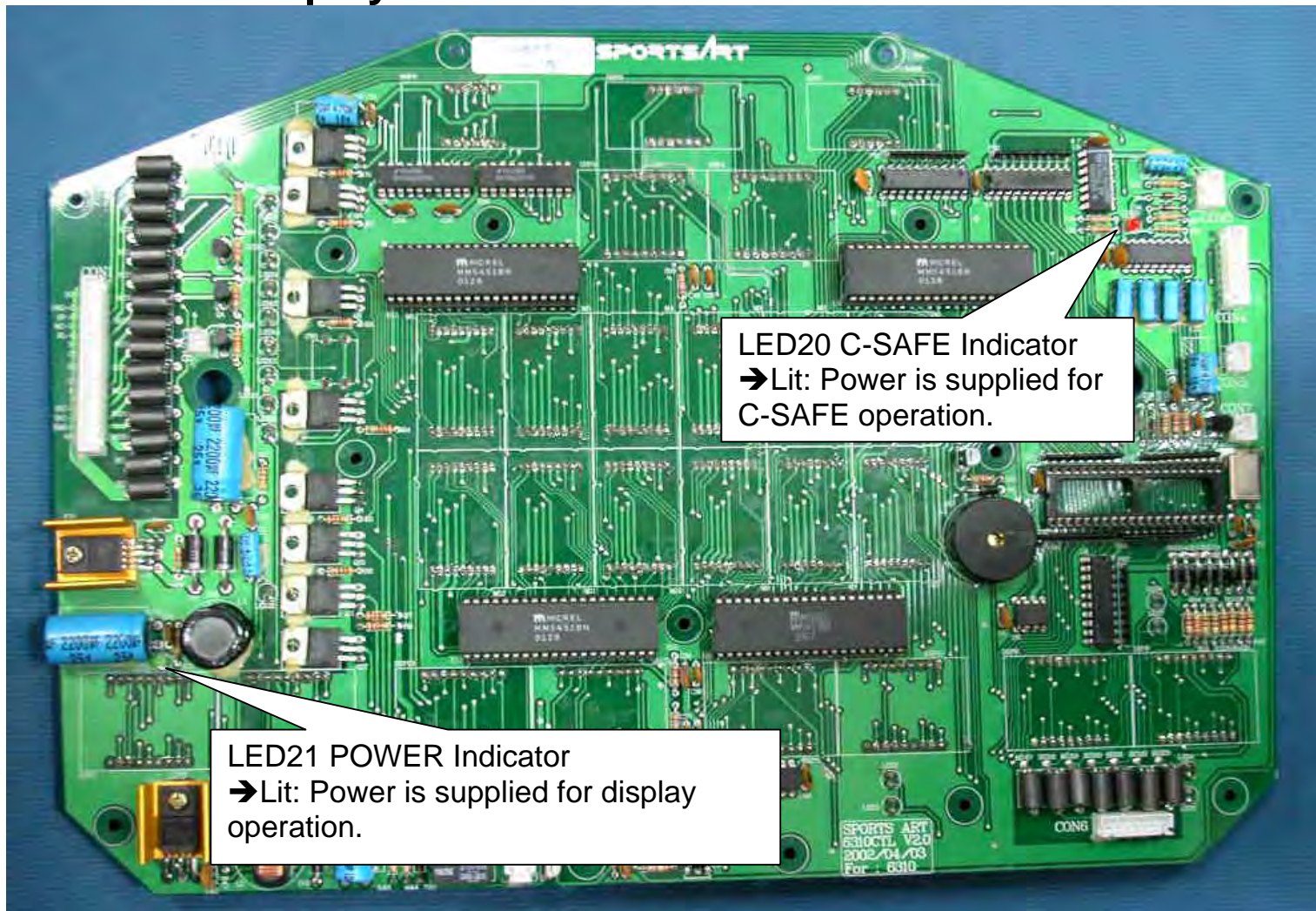

## 6300/6310 Display VCC Circuit Voltage Test

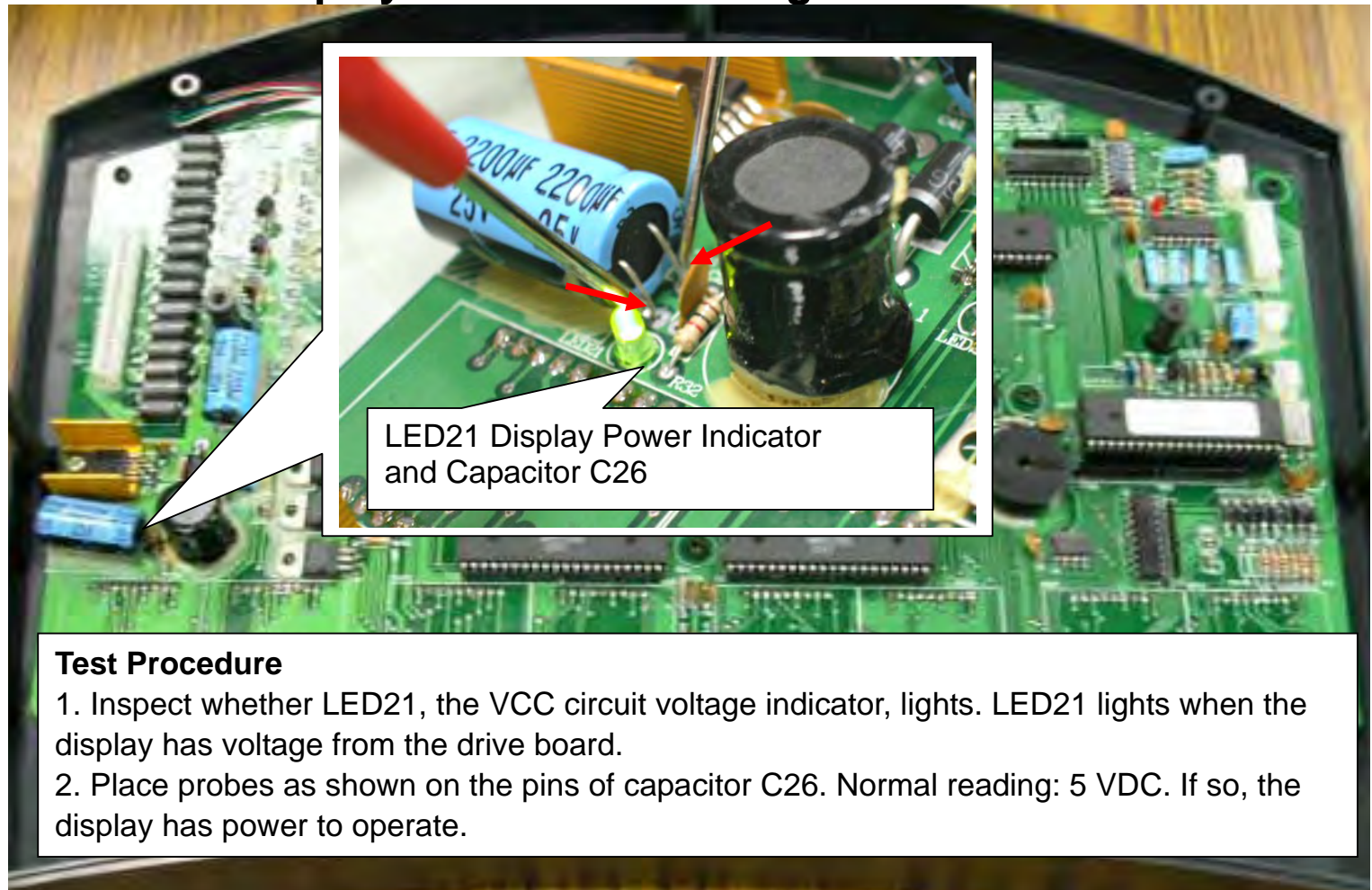

## 6300/6310 Treadmill Electronics Repair Manual – Display

### 6300/6310 Display VBB Circuit Voltage Test

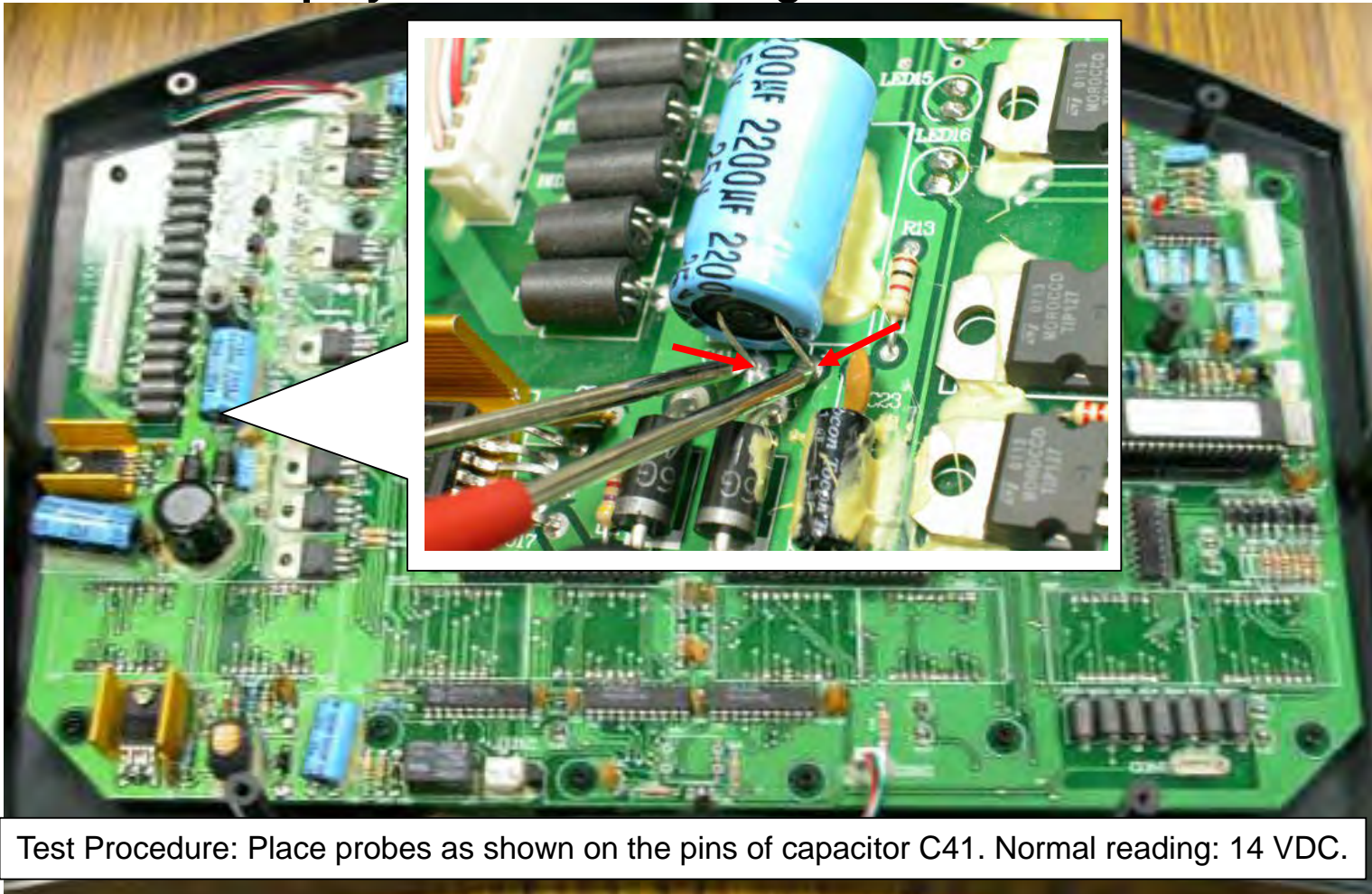

## 6300/6310 Treadmill Electronics Repair Manual – Display

### Display Board Main Program IC U5

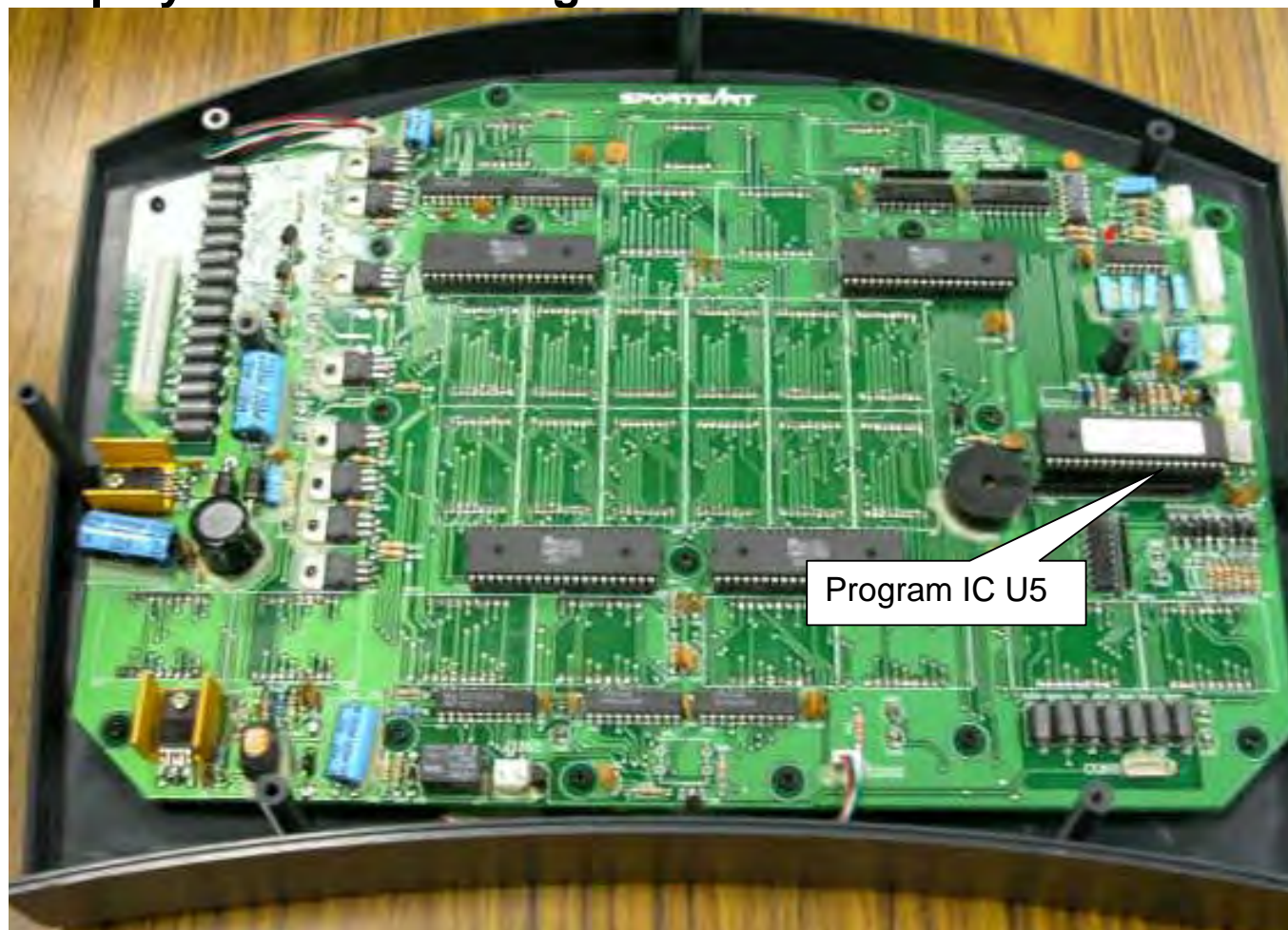

### 6310 Display Board - Front View



## 6300/6310 Treadmill Electronics Repair Manual – Drive

### **6300/6310 Drive Board – Includes 6300/6310 Drive Board Wiring, LEDs**

DRIVE BOARD.01 – Drive Board Wire Connection Diagram

DRIVE BOARD.02 – 6300/6310 Drive Board Wire Connection Picture

DRIVE BOARD.03 – 6300/6310 Drive Board LEDs – Normally Lit

DRIVE BOARD.04 – 6300/6310 Drive Board LEDs – Normally Not Lit

DRIVE BOARD.05 – 6300/6310 Drive Board Picture

## 6300/6310 Treadmill Electronics Repair Manual – Drive

### Drive Board Wire Connections

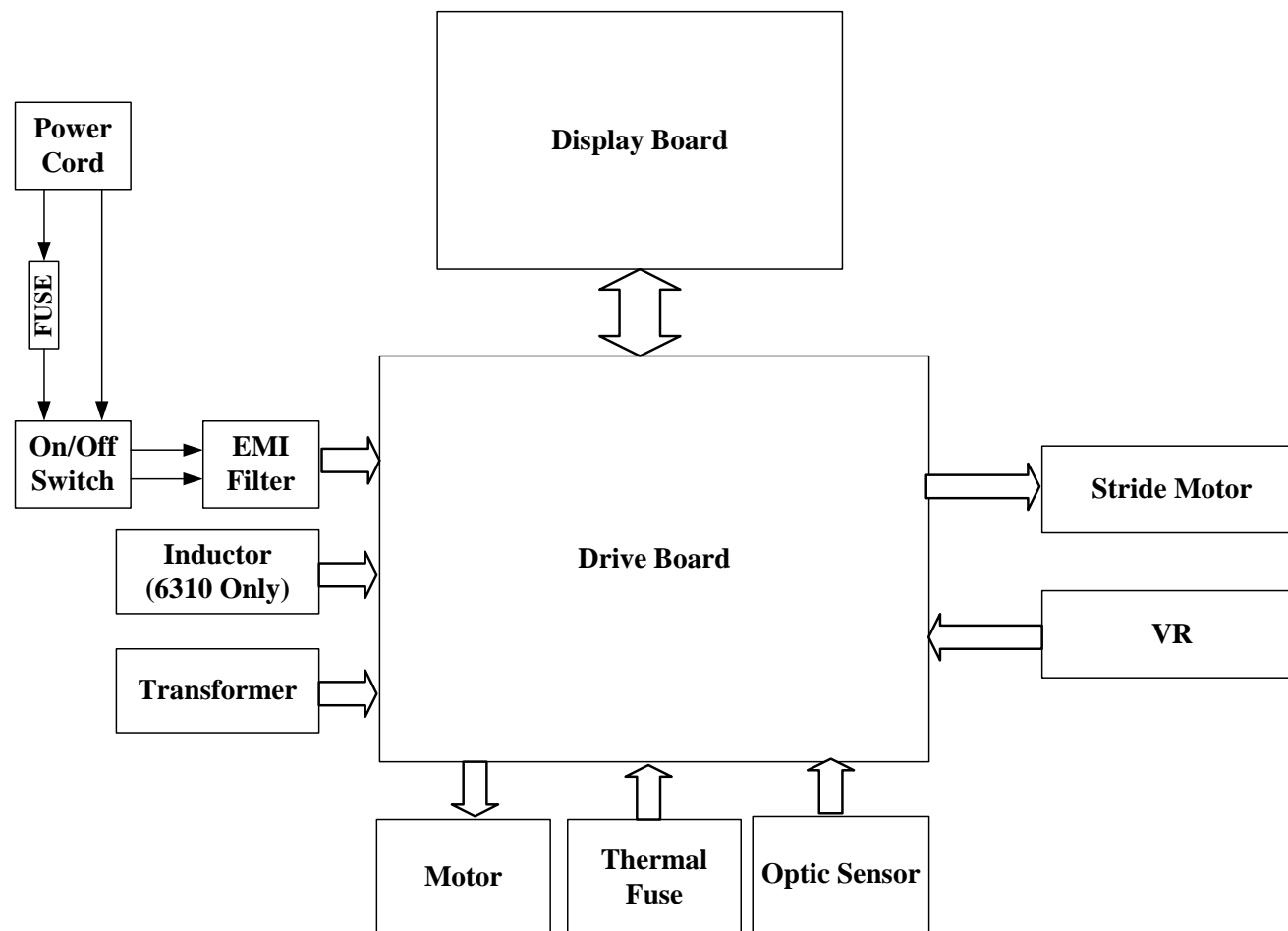

DRIVE.01



### 6300/6310 Drive Board Connection Picture

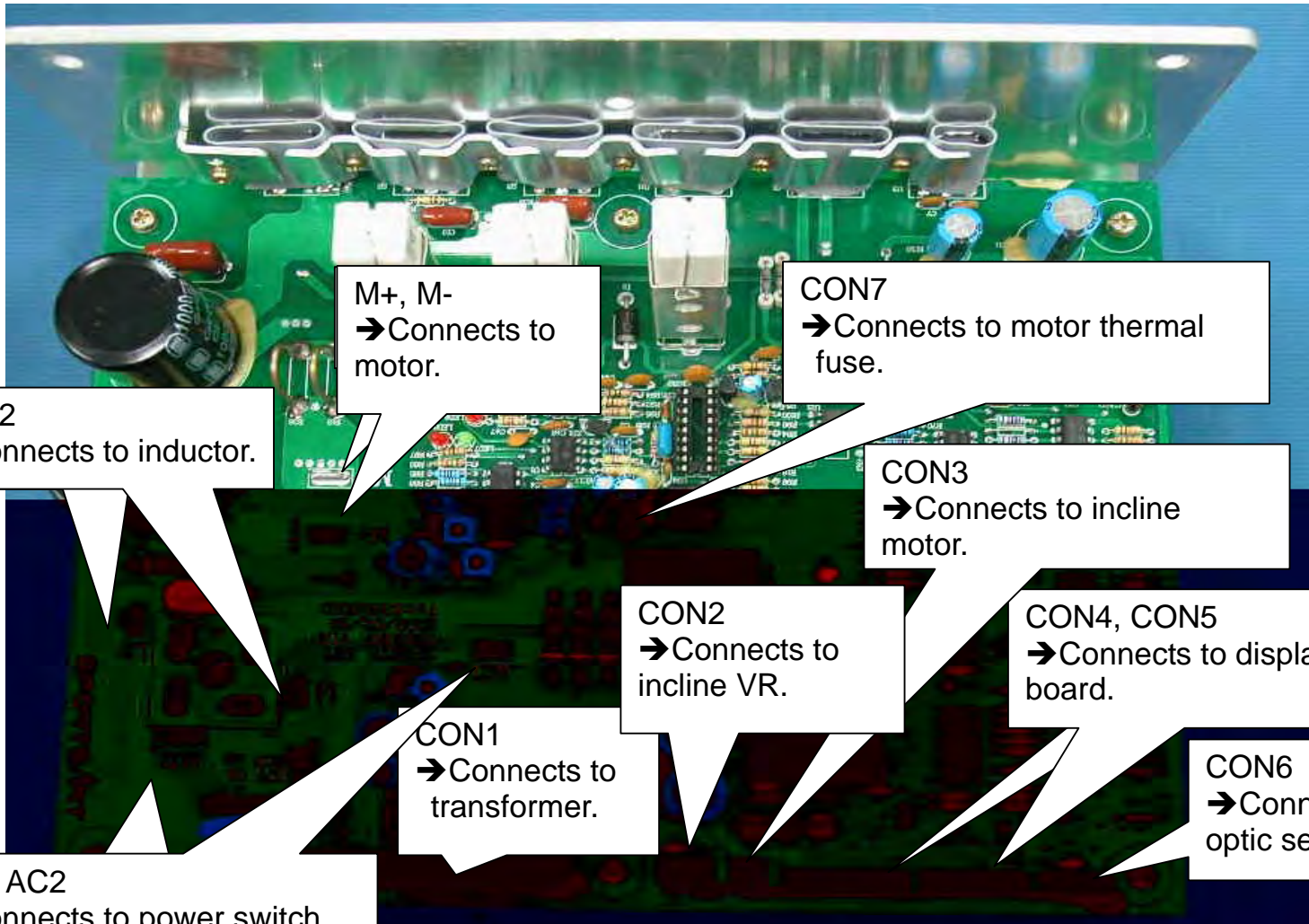

L1, L2  
→ Connects to inductor.

M+, M-  
→ Connects to motor.

CON7  
→ Connects to motor thermal fuse.

CON3  
→ Connects to incline motor.

CON2  
→ Connects to incline VR.

CON4, CON5  
→ Connects to display board.

CON6  
→ Connects to optic sensor.

CON1  
→ Connects to transformer.

AC1, AC2  
→ Connects to power switch.

## 6300/6310 Drive Board LEDs – Normally Lit

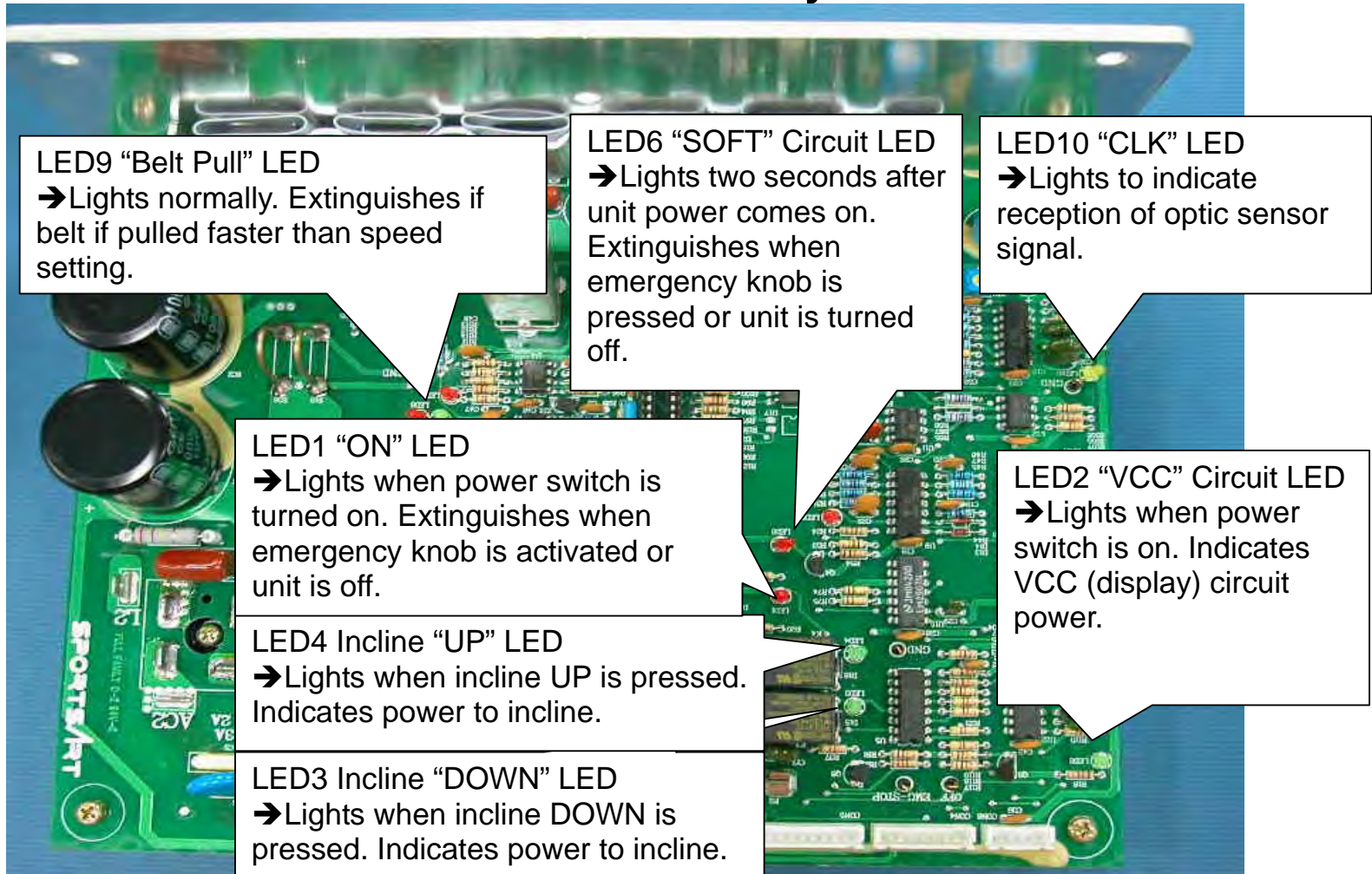

## 6300/6310 Drive Board LEDs – Normally Not Lit

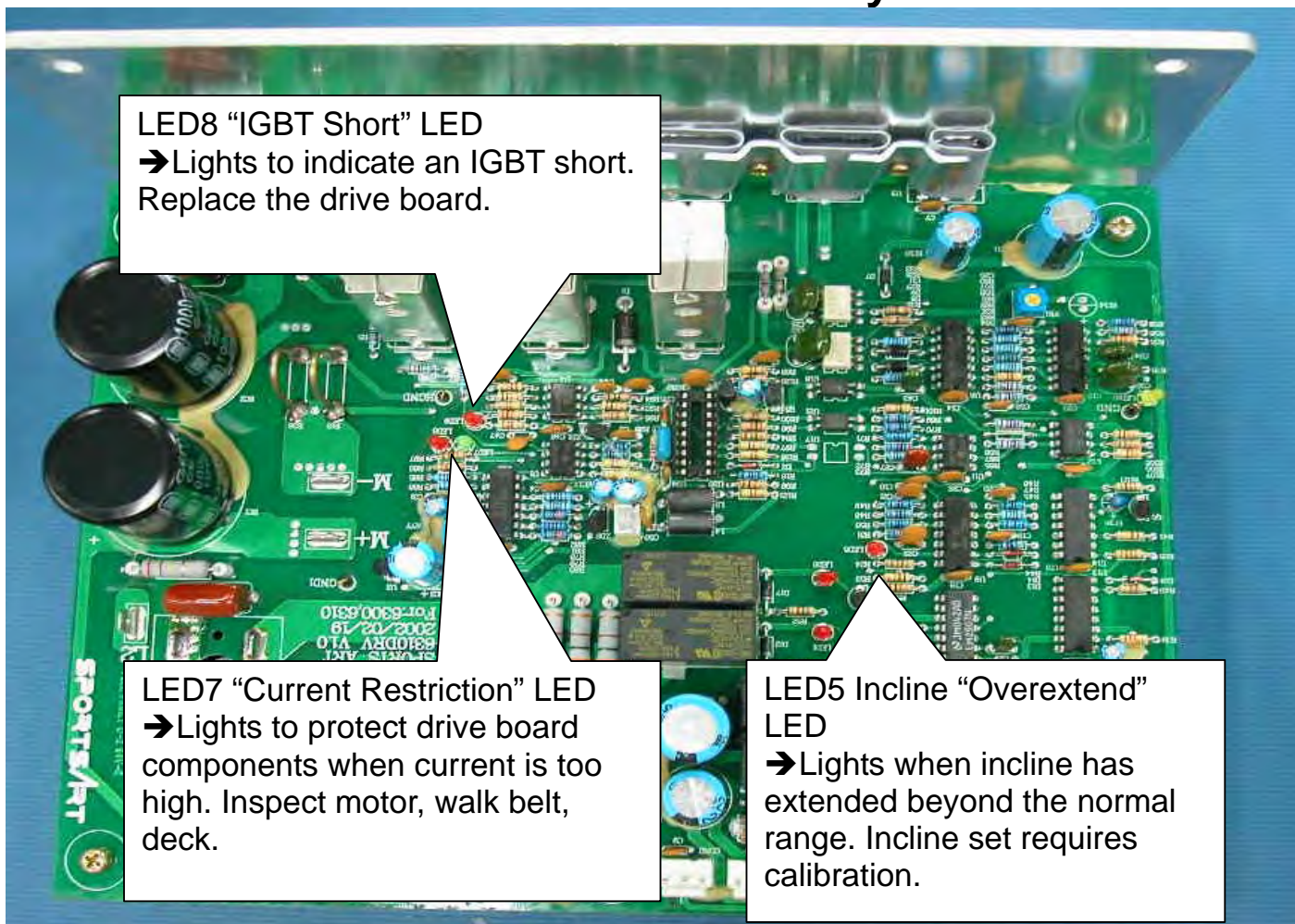

## 6300/6310 Treadmill Electronics Repair Manual – Drive

### 6300/6310 Drive Board Picture



Note: The 6300/6310 drive board has been revised since this picture was taken. The new drive board is version 3.2 and includes a small incline control board which partially covers LED 1, 5 and 6.

## 6300/6310 Treadmill Electronics Repair Manual – Motor

### **6300/6310 Drive Motor System Operation**

MOTOR.01 – 6300/6310 Motor System Operation

MOTOR.02 – 6300/6310 Voltage to Motor – Test Configuration

MOTOR.03 – 6300/6310 Voltage to Motor – Test Procedure, Test Results

MOTOR.04 – 6300/6310 Motor Circuit and OHM Test Configuration, Procedure

MOTOR.05 – 6300/6310 Transformer Test Configuration

MOTOR.06 – 6300/6310 Transformer Test Procedure, Results

MOTOR.07 – 6300/6310 Inductor Test Configuration, Procedure

MOTOR.08 – 6300/6310 Optic Sensor Signal Test

MOTOR.09 – 6300/6310 Optic Sensor Signal Test Procedure, Results

## 6300/6310 Treadmill Electronics Repair Manual – Motor

### 6300/6310 Motor System Operation

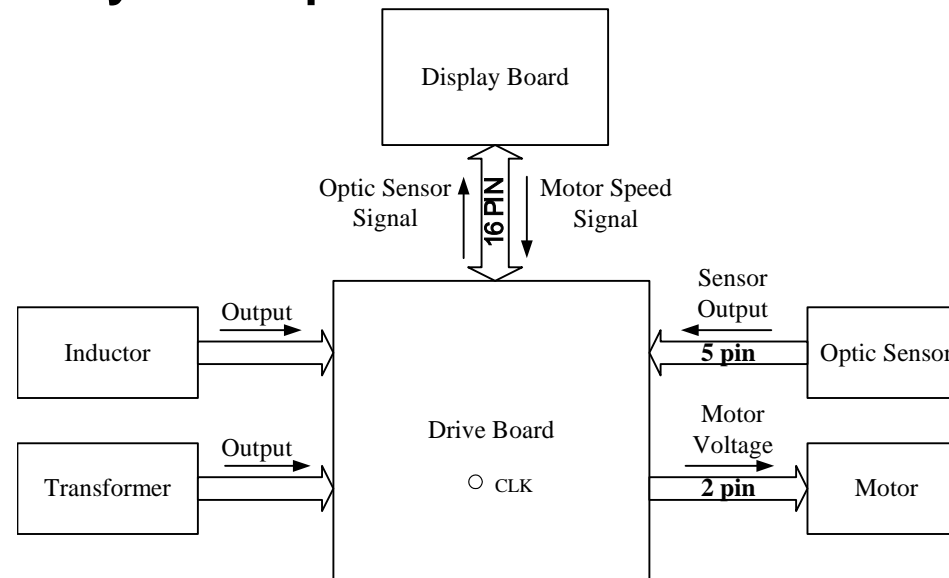

1. Display emits the speed signal, which travels from the ribbon cable to the drive board.
2. The drive board puts out power for the motor. (The transformer splits power into smaller voltages for various circuit operation. The inductor ensures steady current to the motor.)
3. The motor operates according to power from the drive board.
4. The optic sensor clocks motor movement. Its signal travels from the sensor, to the drive board, up the ribbon cable, to the display.
5. The display program IC uses the speed signal from the optic sensor to determine whether to command the drive board to supply more or less voltage to the motor.

## 6300/6310 Treadmill Electronics Repair Manual – Motor

### 6300/6310 Voltage to Motor – Test Configuration

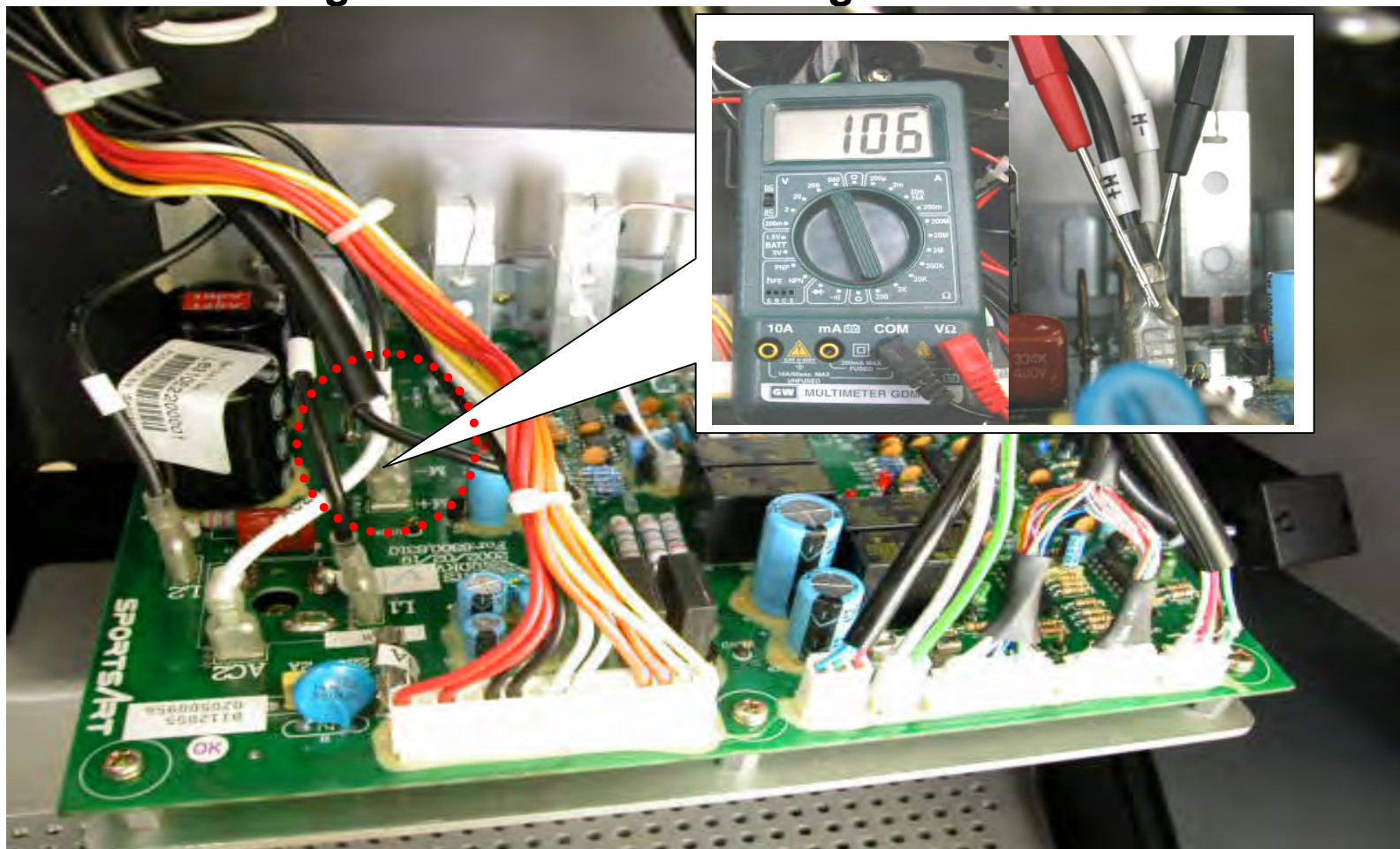

MOTOR.02

## 6300/6310 Treadmill Electronics Repair Manual – Motor

### **6300/6310 Voltage to Motor – Test Procedure**

1. Put multimeter to the DC voltage setting. Place probes as shown on the drive board M+ and M- connectors.
2. Turn on unit power. Press SPEED<▲> key. The multimeter should show an increase in voltage. The motor should operate. At the highest speed (12.0 MPH), the multimeter should show 100-120 VDC.

### **6300/6310 Voltage to Motor – Test Results**

If there is no voltage across M+ and M- connectors, the drive board is not supplying power.

Inspect the following:

1. Drive board power indicator, LED2. If LED2 does not light, trace power from the wall into the unit, to see where the power stops. Also, inspect fuses.
2. Drive board IGBT short indicator, LED8. If LED8 lights, the IGBT has a short. Replace the drive board.
3. Transformer and its wire connectors. See TESTING – TRANSFORMER.1.
4. Test the drive board by replacing it with a new one.

If the drive board does provide power, but the motor does not operate, inspect the motor wire connections. If the wires are good and the connections are good, but the motor does not operate, the motor is bad. Replace it.



## 6300/6310 Treadmill Electronics Repair Manual – Motor

### 6300/6310 Motor Integrity and OHM Test Configuration

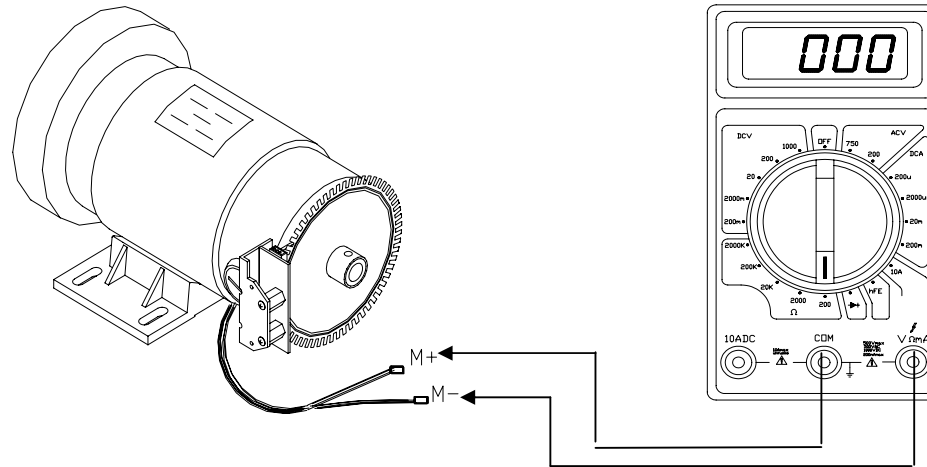

#### 6300/6310 Motor Integrity Test Procedure

Remove the M+ M- wires from the drive board. Put multimeter to the 200 VDC setting. Place one probe on the M+ wire. Place the other probe on the M- wire. Spin the motor flywheel with your hand. Normal results: The faster the motor spins, the more voltage is produced. If no voltage is produced, replace the motor.

#### 6300/6310 Motor OHM Test Procedure

Remove the M+ M- wires from the drive board. Put multimeter to the OHM setting. Place one probe on the M+ wire. Place the other probe on the M- wire. Normal reading: 1 to 4 Ohm. Turn the flywheel slightly and take another reading. Take readings in small steps until the flywheel completes a full rotation. All readings should be within 1 to 4 Ohm. "0" would indicate a short; OL would indicate a break; Replace the motor.

## 6300/6310 Treadmill Electronics Repair Manual – Motor

### 6300/6310 Transformer Test - Configuration

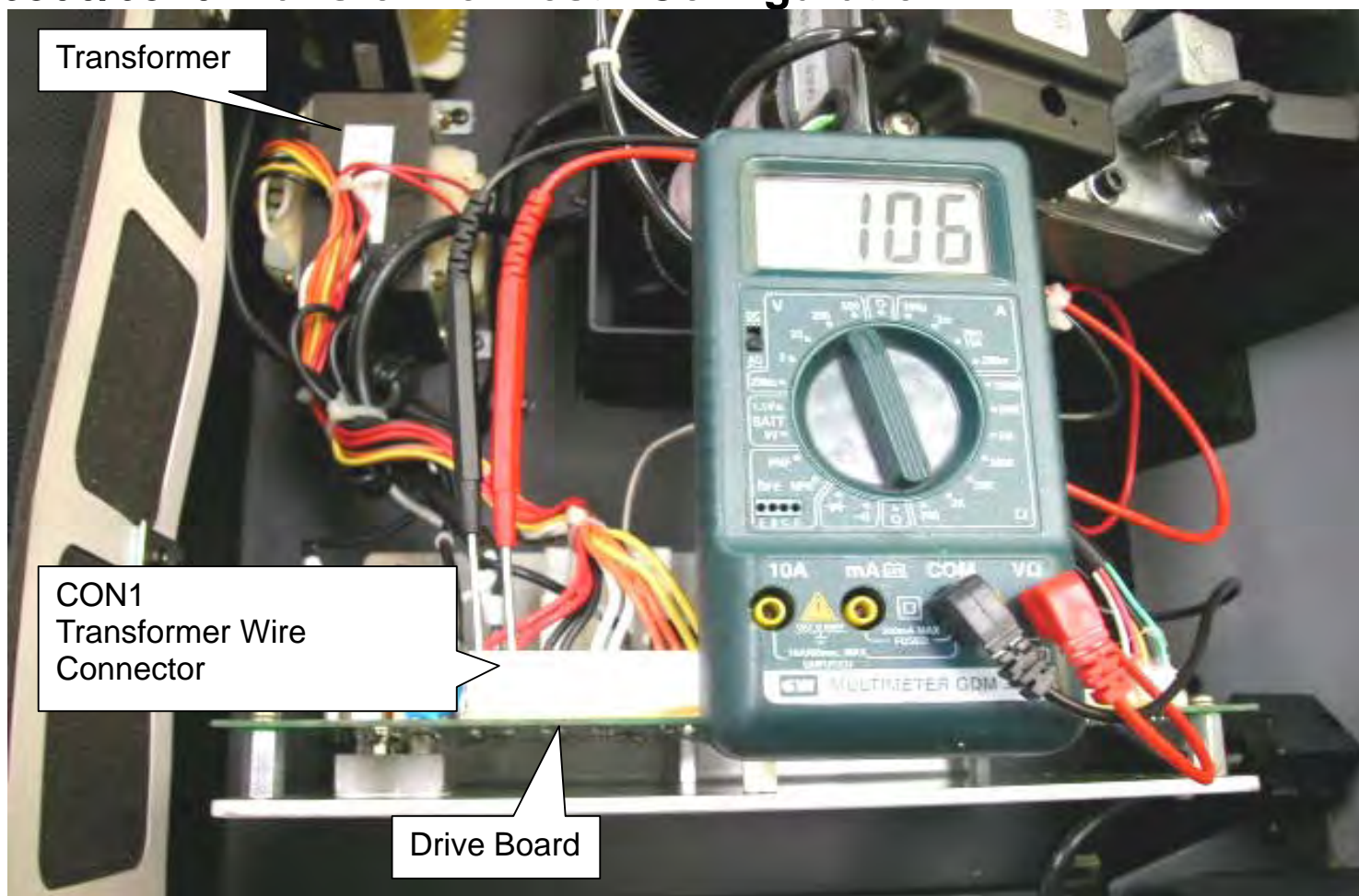

MOTOR.05

## 6300/6310 Treadmill Electronics Repair Manual – Motor

### 6300/6310 Transformer Test Procedure

1. Make sure that transformer wire connections (CON1) to the drive board are secured. Turn unit on.
2. Put multimeter to the AC voltage setting. Insert meter probes into the transformer primary (red) wires as shown. Normal reading: 110V. This shows that there is power to the transformer.
3. Test transformer output by probing on secondary (output) wires: black and black, white and white, orange and orange, yellow and yellow.



Transformer Wire Colors	Normal Voltage Value
Red and Red	110 VAC
Black and Black	11-13 VAC
White and White	11-13 VAC
Orange and Orange	27-29 VAC
Yellow and Yellow	10-12 VAC

### 6300/6310 Transformer Test Results

1. If there is no voltage across the primary (red) wires, inspect F1 fuse on the drive board and power to the drive board.
2. If there is voltage across primary wires but none across secondary wires, the transformer is bad. Replace it.

## 6300/6310 Treadmill Electronics Repair Manual – Motor

### 6300/6310 Inductor Test Configuration

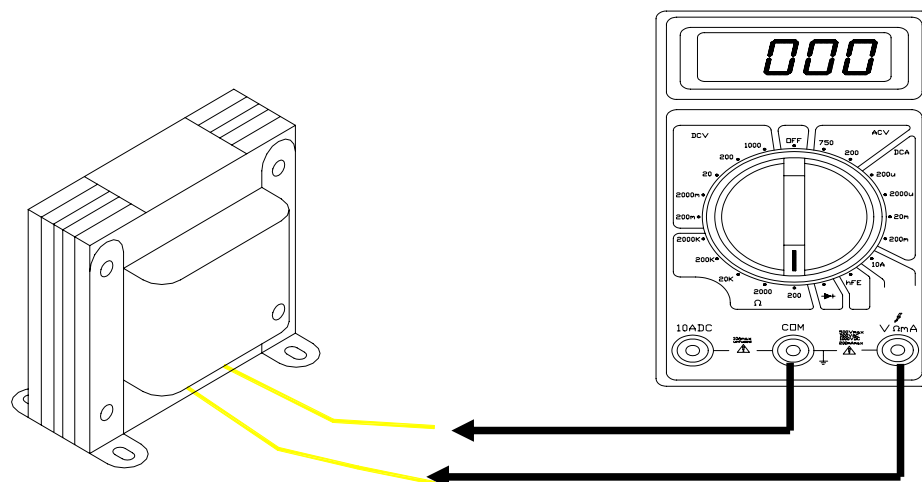

### 6300/6310 Inductor Test Procedure

1. Disconnect the inductor wires from the drive board.
2. Put multimeter to the Ohm setting. Place one probe on each wire end.
3. Normal reading: 0.4 Ohm.
4. If there is no reading (OL), or a reading of 0 Ohm, or if the inductor makes a “wong” sound as the user’s heel strikes the belt, replace the inductor.

## 6300/6310 Treadmill Electronics Repair Manual – Motor

### 6300/6310 Optic Sensor Signal Test

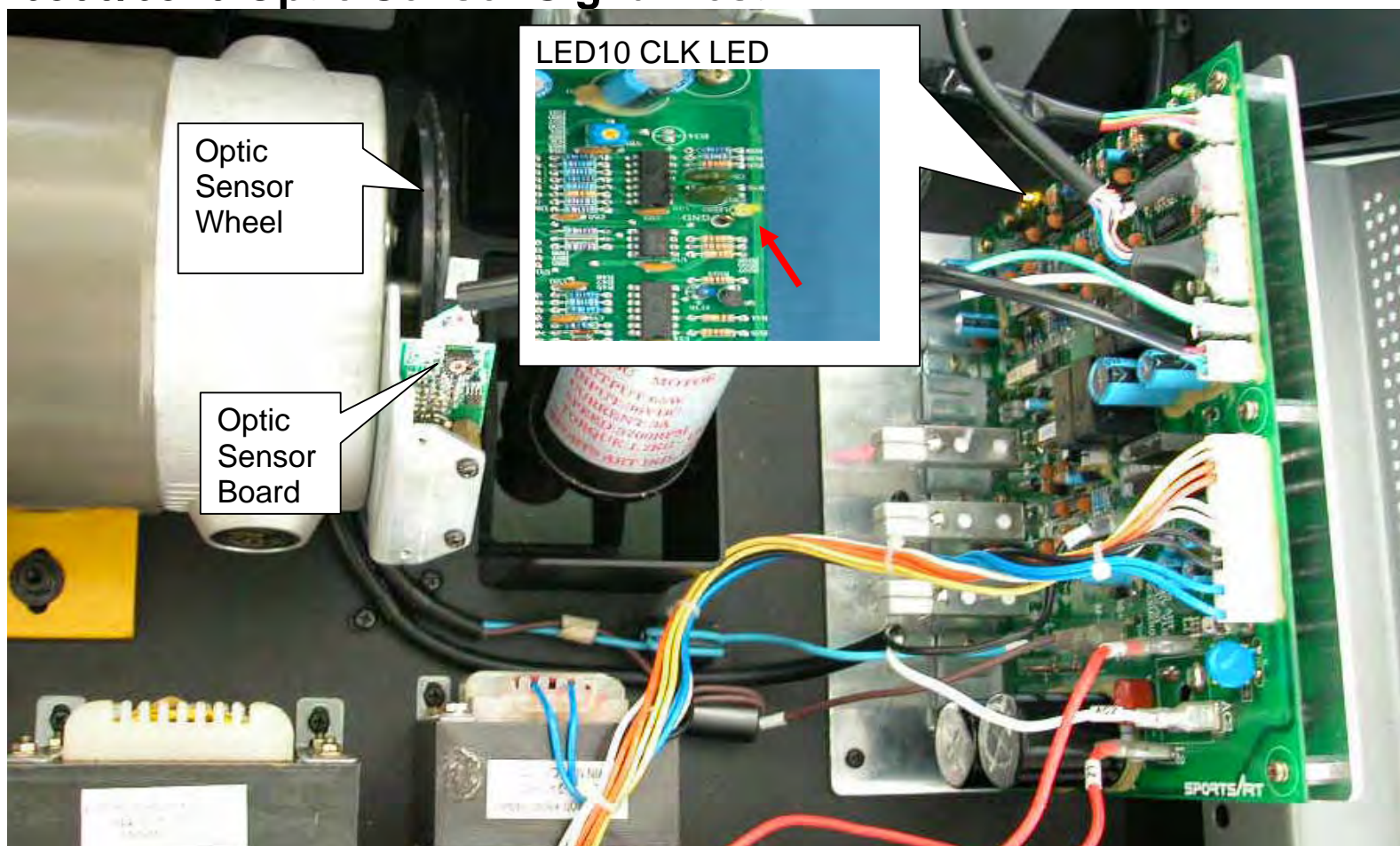

## 6300/6310 Treadmill Electronics Repair Manual – Motor

### **6300/6310 Optic Sensor Signal Test Procedure**

Turn on unit power. Do not press display keys. Use your hand to rotate the motor flywheel. Normal result: LED 10 lights to indicate the optic sensor signal entering the drive board. The LED appears to flicker at a low speed and remain lit at high speed.

### **6300/6310 Optic Sensor Signal Test Results**

If LED10 does not light, inspect:

1. Optic sensor signal wires and their connections; Reinsert wire ends into connectors.
2. Whether optic sensor wheel rotates in the middle of the sensor; If not, reinstall the optic sensor wheel.
3. Whether optic sensor wheel teeth are broken or bent; if so, replace the optic sensor wheel.
4. If LED2, the VCC circuit indicator, on the drive board lights and there is no optic sensor signal output (LED10 does not light), and if optic sensor wires and connections are good, replace the optic sensor.

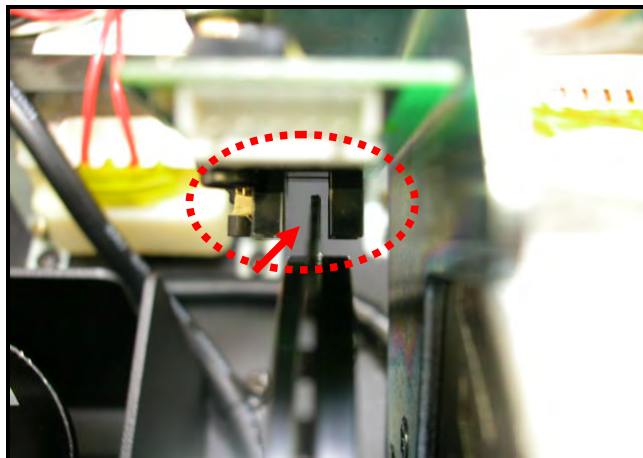

## 6300/6310 Treadmill Electronics Repair Manual – Incline

### **6300/6310 Incline System Operation**

INCLINE.01 – 6300/6310 Incline System Operation

INCLINE.02 – 6300/6310 Voltage to Incline Motor – Test Configuration

INCLINE.03 – 6300/6310 Voltage to Incline Test Procedure, Results

INCLINE.04 – 6300/6310 Incline VR Voltage – Test Configuration

INCLINE.05 – 6300/6310 Incline VR Voltage Test Procedure, Results

## 6300/6310 Treadmill Electronics Repair Manual – Incline

### 6300/6310 Incline System Operation

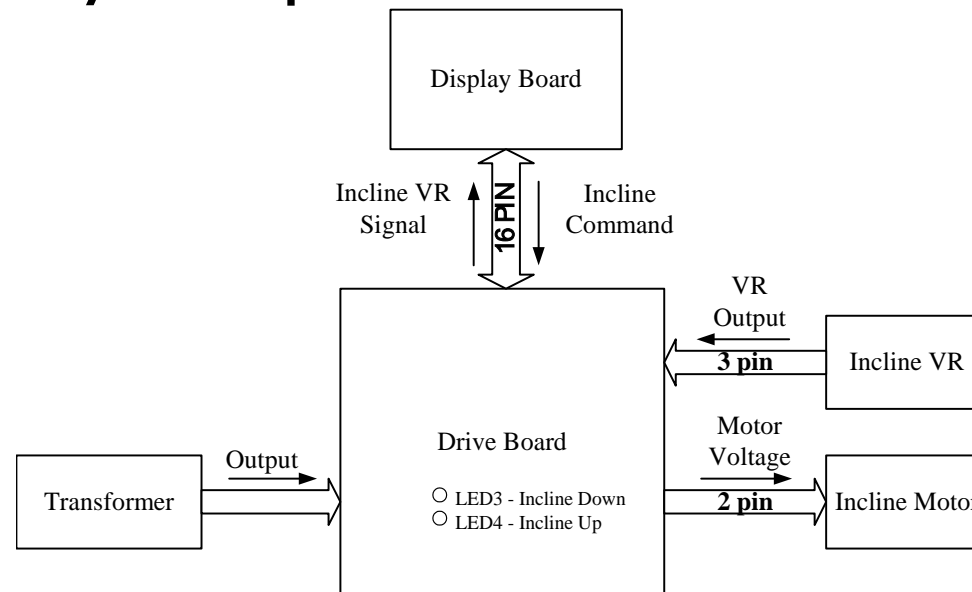

1. Display emits the incline signal, which travels from the ribbon cable to the drive board.
2. The transformer breaks wall power down into smaller voltages for various circuit operation, including the incline motor.
3. The drive board puts out power for the motor. Up operation: K4 relay clicks, LED 4 lights. Down operation: K2 relay clicks, LED 3 lights.
4. The incline motor operates according to power from the drive board. UP operation: K4 relay clicks, LED 4 lights. Down operation: K2 relay clicks, LED 3 lights.
5. As the incline motor moves, the variable resistor (VR) moves, changing VR output voltage. The VR voltage travels to the drive board, up the ribbon cable, to the display.
6. The display program IC uses the VR signal to determine the position of the incline. This is used to determine whether to supply or cut off power for incline motor operation.



# 6300/6310 Treadmill Electronics Repair Manual – Incline

## 6300/6310 Voltage to Incline Motor - Test Configuration

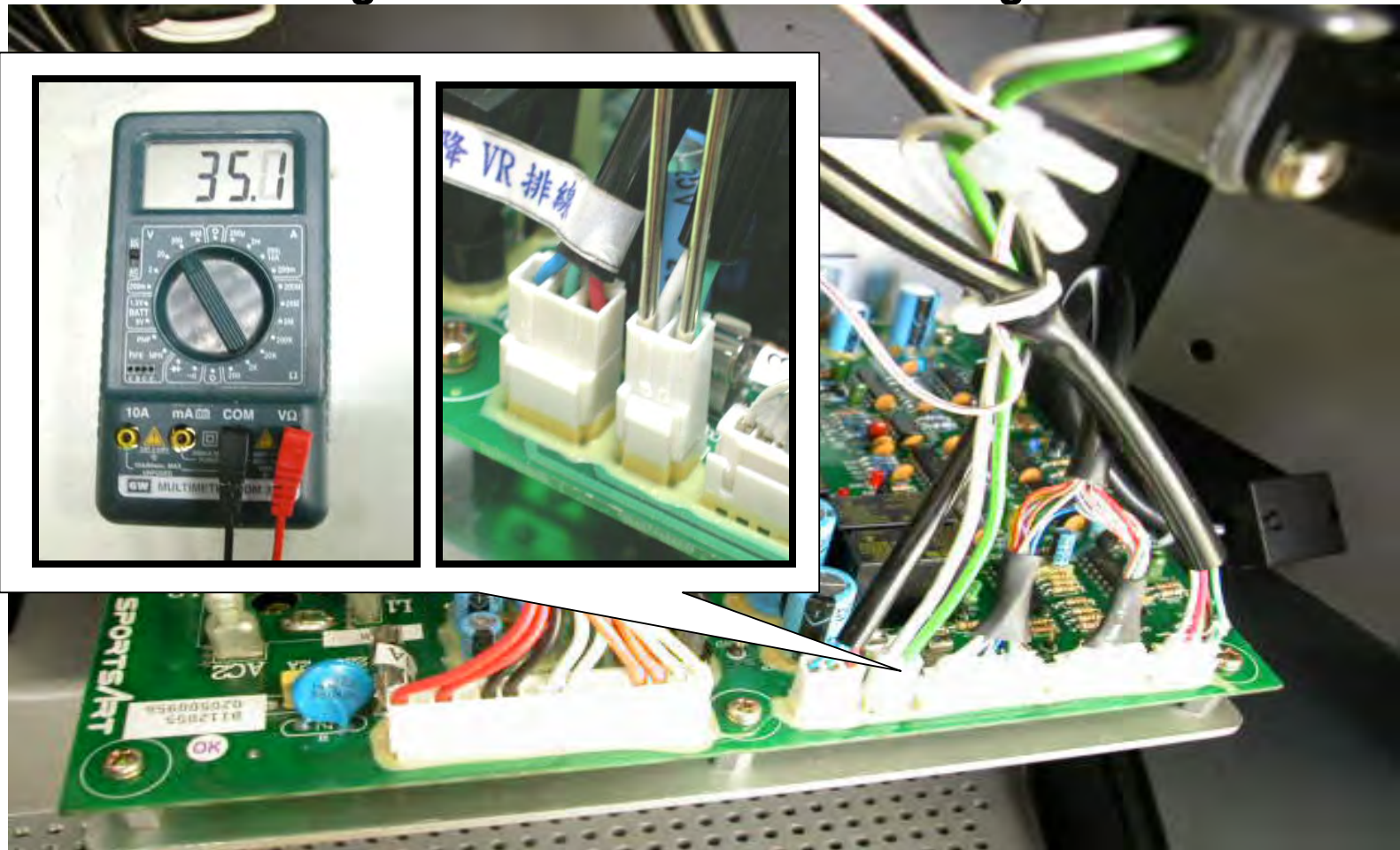

## 6300/6310 Treadmill Electronics Repair Manual – Incline

### **6300/6310 Voltage to Incline Test Procedure**

1. Put multimeter to the DC Voltage setting. Insert the red probe into the CON3 white wire connector. Insert the black probe into the CON3 green wire connector. Turn on unit power.
2. Press INCL<▲> key. K4 relay clicks; LED4 lights. Normal reading: +35 VDC. Incline operates up.
3. Press INCL<▼> key. K2 relay clicks; LED3 lights. Normal reading: -35 VDC. Incline operates down.

### **6300/6310 Voltage to Incline Test Results**

If not as above, inspect the following:

1. In manual mode, press an incline up or down key. The display should beep once. If not, inspect the display.
2. Test the transformer voltage (see TESTING - TRANSFORMER.1 in Motor System Operation); Check for 35 VDC across the orange wires.
3. If LED 5 on the drive board lights or ERR7 appears, recalibrate the incline set and test incline operation again.
4. If the display beeps when incline keys are pressed, but the drive board incline up and down LEDs don't light, inspect the ribbon cable (check continuity). If the ribbon cable is good and the transformer is good, replace the drive board.

## 6300/6310 Treadmill Electronics Repair Manual – Incline

### 6300/6310 Incline VR Voltage - Test Configuration

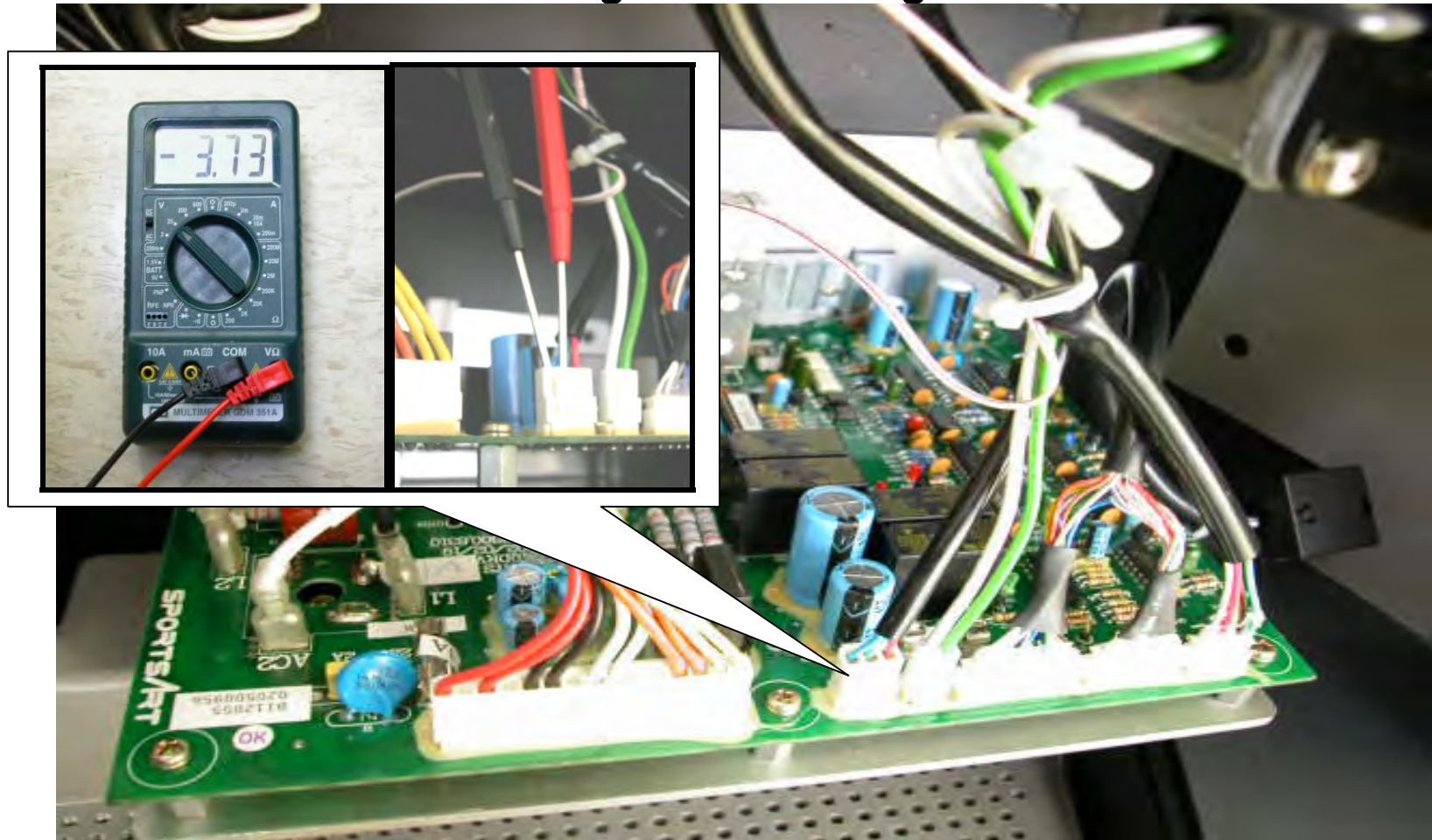

INCLINE.04

## 6300/6310 Treadmill Electronics Repair Manual – Incline

### **6300/6310 VR Voltage Test Procedure**

1. Put multimeter to the DC Voltage setting. Place one probe on the CON2 connector blue wire. Place the other probe on the CON2 connector green wire.
2. Turn on unit power. Normal reading: 1.10 to 3.60 VDC.
3. Press the INCL<▲> key until the incline window shows 15%. The incline arrives at the highest position. Normal reading: 3.80 VDC.
4. Press the INCL<▼> key until the incline window shows 0%. The incline arrives at the lowest position. The red line on the thin pipe is visible just above the red line on the thick pipe. Normal reading: 1.20 VDC.

### **6300/6310 VR Voltage Test Results**

1. If not as above, recalibrate the VR and incline motor.
2. If the VR voltage jumps during incline operation or fails to calibrate properly, replace the VR.

## 6300/6310 Treadmill Electronics Repair Manual – Calibration

### **6300/6310 Incline Calibration**

CALIBRATION.01 – 6300/6310 Incline Calibration Overview

CALIBRATION.02 – Mechanical Calibration

CALIBRATION.03 – Electronic Calibration

CALIBRATION.04 – Incline Calibration Testing

## 6300/6310 Treadmill Electronics Repair Manual – Calibration

### 6300/6310 Incline Calibration Overview

Incline calibration is necessary when:

- the display shows ERR7;
- the drive board incline error LED ( LED5) lights;
- or the incline has extended beyond its normal range.

The goal of calibration is to synchronize the incline set mechanically and electronically.

Mechanical calibration sets the incline motor pipe to the 0% position. This happens when the red line on the thin pipe is even with the end of the thick pipe.

Electronic calibration sets the variable resistor (VR) value to the 0% position. This happens when the voltage across the VR blue and green wires is 1.20 VDC.

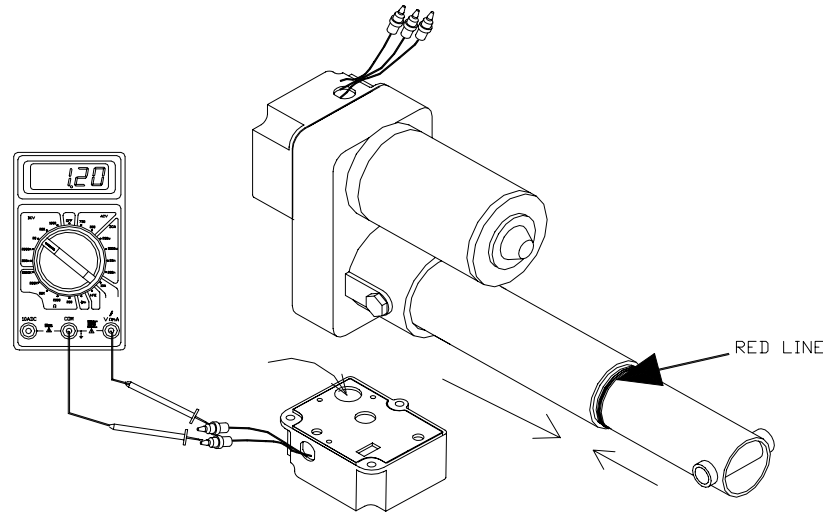

CALIBRATION.01

## 6300/6310 Treadmill Electronics Repair Manual – Calibration

### Mechanical Calibration

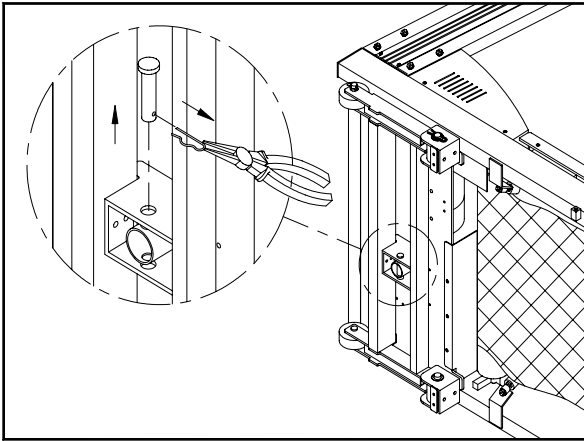

Step 1. Turn the unit on its side, and pull out the incline pin.



Step 2. Turn the incline motor pipe until the red line on the thin pipe is visible just above the end of the thick pipe.

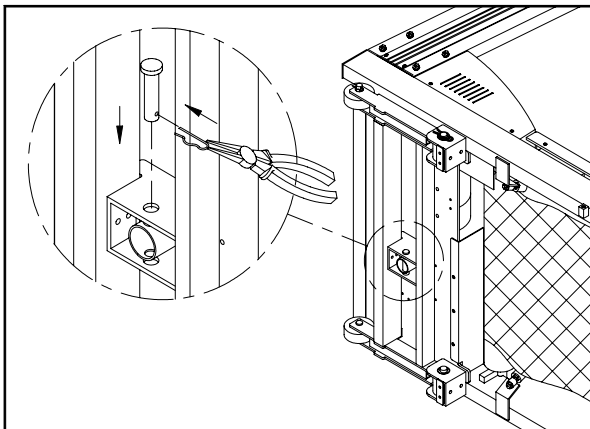

Step 3. Insert the incline pin.

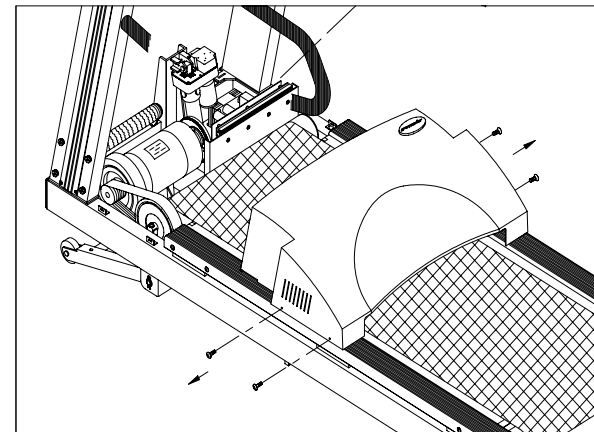

Step 4. Right the unit and remove the motor cover.

# 6300/6310 Treadmill Electronics Repair Manual – Calibration

## Electronic Calibration

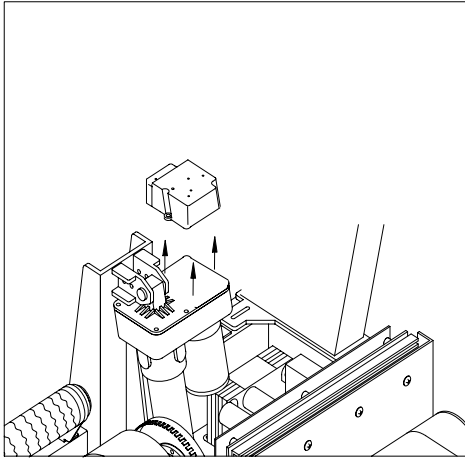

Step 1. Remove the VR cover but do not detach VR wires.

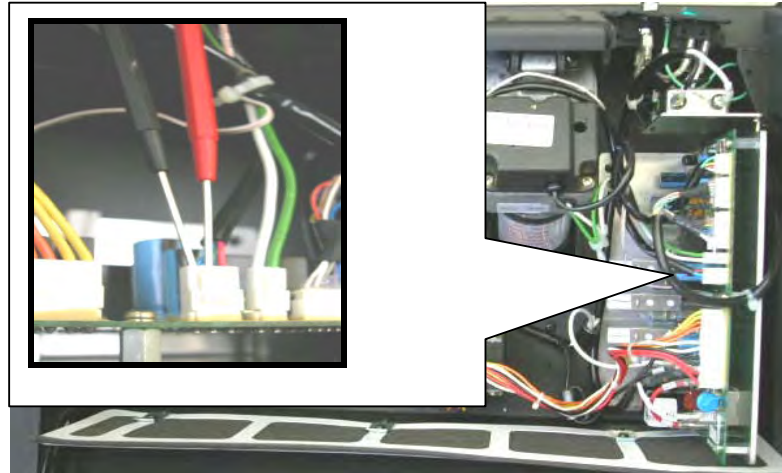

Step 2. Set multimeter to the DC volt setting. Insert multimeter probes into the VR blue and green wire connectors on the drive board.

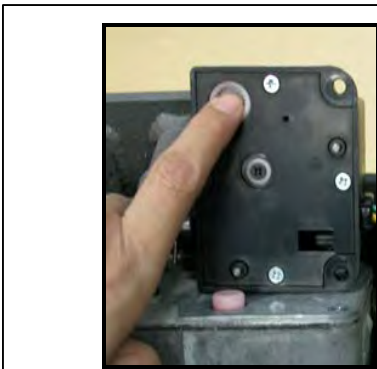

Step 3. Turn the VR gear until the multimeter shows 1.20 VDC.

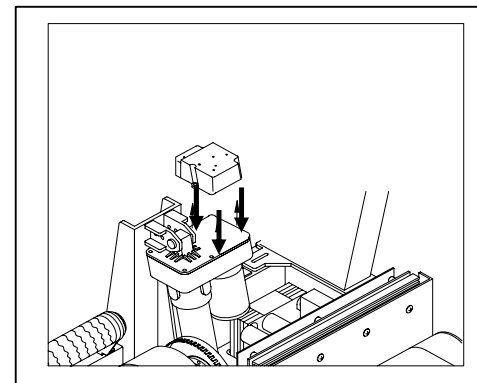

Step 4. Secure the VR, then secure motor cover.



## 6300/6310 Treadmill Electronics Repair Manual – Calibration

### **Incline Calibration Testing**

Test the calibration by running the incline.

- At the physical 0% position, the display should show 0% incline.
- At the physical 15% position, the display should show 15% incline.
- Incline operation should be smooth.
- Readings of VR voltage (blue and green wires) should show around 1.20 VDC at the lowest position and around 3.80 VDC at the highest position.

If the VR loses calibration or cannot be set to 1.20 VDC, replace the VR.

If the incline motor gets voltage from the drive board but fails to operate, replace the incline motor set.

If the incline fuse blows again and again, replace the incline motor set.

## 6300/6310 Treadmill Electronics Repair Manual – Heart Rate

### **6300/6310 Heart Rate System Operation**

HR.01 – Heart Touch Rate (HTR) Operation

HR.02 – POLAR Heart Rate (HR) Operation

HR.03 – HTR Board LED Operation, LED Indicator Definitions

HR.04 – Possible Malfunctions, Troubleshooting

HR.05 – HTR Cable/Handlebar Test Procedure

## 6300/6310 Treadmill Electronics Repair Manual – Heart Rate

### Heart Touch Rate (HTR) Operation

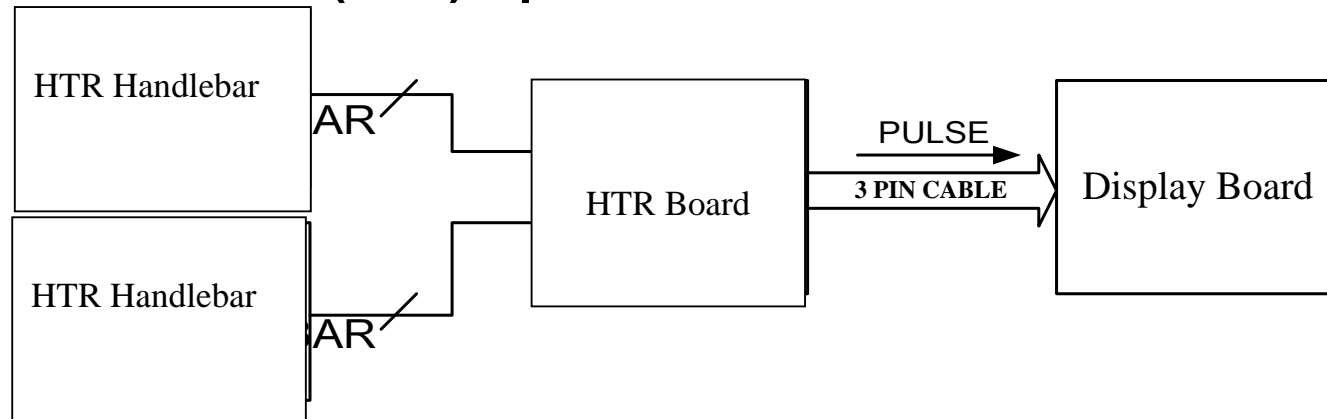

Order	Part	Operation
1	HTR Handlebar	1. Place both hands on the HTR handlebars. The handlebars detect the user's pulse. 2. The pulse signal travels across wires from the handlebars to the HTR board. 3. LED2 and LED4 on the HTR board light up when the user holds onto the handlebars.
2	HTR Board	1. The HTR board receives, processes, and transmits pulse signals. 2. LED3 flashes each time an incoming pulse signal is received. 3. LED4 flashes each time an outgoing pulse signal is sent to the display board. 4. The HTR board sends its heart rate signal to the display board.
3	3-PIN Cable	1. The heart rate signal travels the 3-pin cable from the HTR board to the display board.
4	Display	1. The display board CPU detects the digital heart rate signal and determines the heart rate value. 2. The display PULSE window shows the heart rate value.

## POLAR Heart Rate (HR) Operation

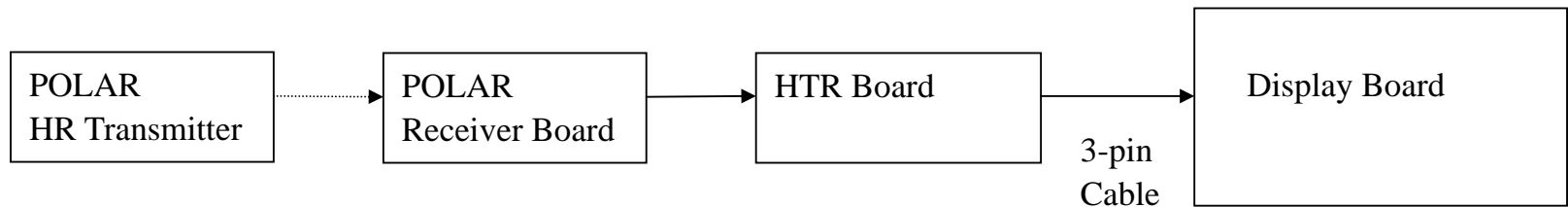

Order	Part	Operation
1	HR Transmitter	1. User wears the POLAR heart rate strap. 2. POLAR transmitter detects the user's heart rate. 3. Then it transmits the heart rate signal to the receiver.
2	POLAR HR Receiver	1. The POLAR receiver board receives the POLAR transmitter signal. 2. The POLAR signal goes to the HTR board. After processing the heart rate signal, the HTR board sends it to the display board.
3	3-pin Cable	1. The heart rate signal travels the 3-pin cable from the HTR board to the display board.
4	Display	1. The CPU detects the heart rate signal. 2. The display shows the heart rate value.

## HTR Board LED Operation

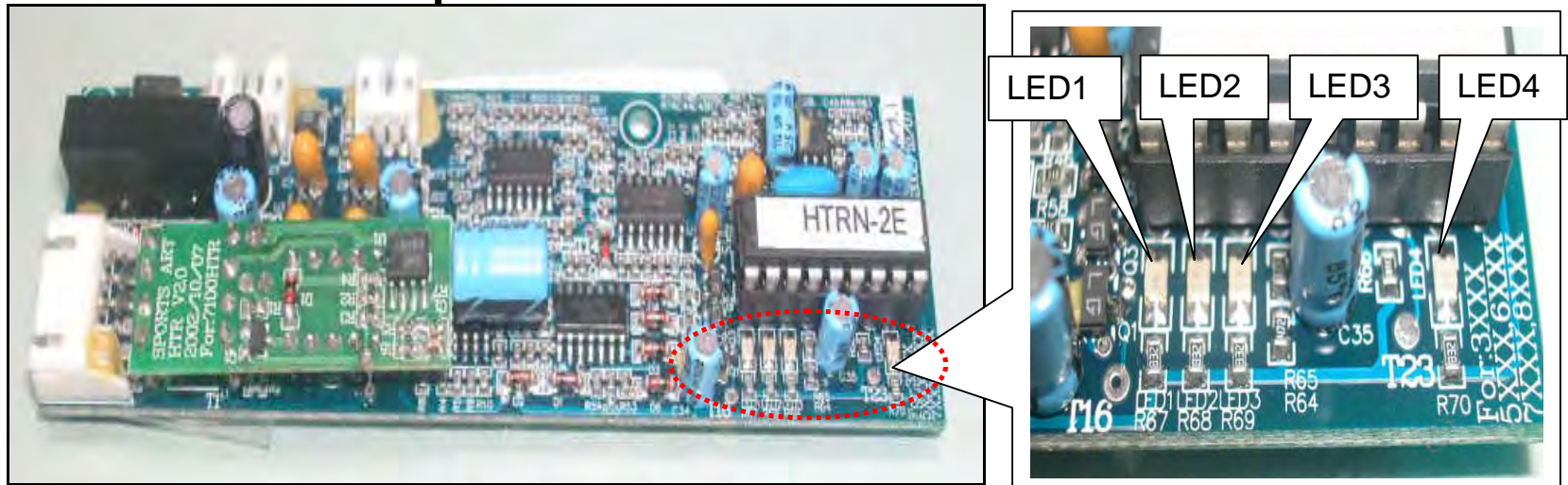

## LED Indicator Definitions

Function	LED1	LED2	LED3	LED4
HTR	X - Not lit in HTR mode.	Lights when user holds onto HTR handlebars.	Flashes to indicate incoming HTR signal.	Lights when HTR handlebars are held; Flashes when HTR signal is sent to display.
POLAR	Flashes to indicate incoming POLAR signal.	X - Doesn't light in POLAR mode.	X - Doesn't light in POLAR mode.	Flashes when POLAR signal is sent to display.

## 6300/6310 Treadmill Electronics Repair Manual – Heart Rate

### Possible Malfunctions

1. Strap on a Polar heart rate transmitter or hold onto the HTR handlebar. The display PULSE window shows no heart rate value.
2. The PULSE window shows the heart rate value inappropriately – when no one touches the HTR handlebar or when no one wears the Polar strap.
3. Place hands on the HTR handlebar or wear the Polar strap. The display PULSE window value differs greatly from the user's actual heart rate.

### Troubleshooting

Malfunction	Cause	Inspect
LED1 (POLAR) not flashing	POLAR receiver is not detecting a heart rate or the signal is not getting to the HTR board.	POLAR transmitter, POLAR receiver board, wires
LED2 (HTR) not lighting	HTR handlebar is not being held or there is no detection of a signal at the HTR board.	HTR handlebar, wire from HTR board to handlebar (See HR.05.)
LED3 (HTR) not flashing	Signal is not arriving from HTR handlebars.	HTR handlebar, cable, HR board (See HR.05.)
LED4 (HTR+POLAR) not flashing	POLAR receiver or HTR is not emitting a heart rate signal to the display.	If all other HTR board LEDs are normal, replace the HTR board.
Display Shows No HR Value	If HTR board LEDs are normal, inspect the 3-pin cable, its connections, and the display board.	3-pin cable, connections, display board

# 6300/6310 Treadmill Electronics Repair Manual – Heart Rate

## HTR Cable/Handlebar Test Procedure

A lack of continuity or a short in the wiring between the HTR board and handlebars could result in either no heart rate reading, intermittent readings, or bad heart rate readings.

Follow directions below to test the 5-pin HTR cable. (1) Turn off unit power. Remove the 5-pin cable from the HTR board. (2) Set multimeter to read continuity. (If your multimeter does not have an audible continuity setting, set your meter to the 200 OHM setting. A reading of 0 ohms is direct continuity. No reading or OL (open line), indicates no continuity.) Place probes as indicated in Fig. 1 and 2 below. (3) Normal readings are shown in the charts below.

Fig. 1. Place red probe on points here.

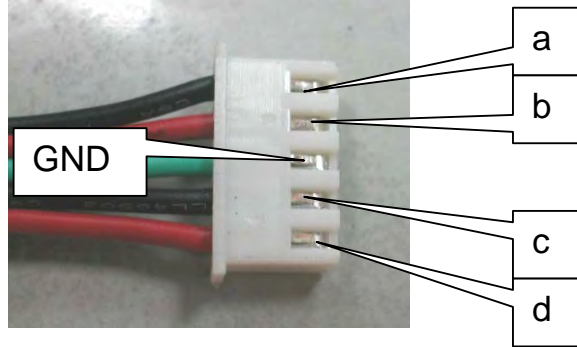
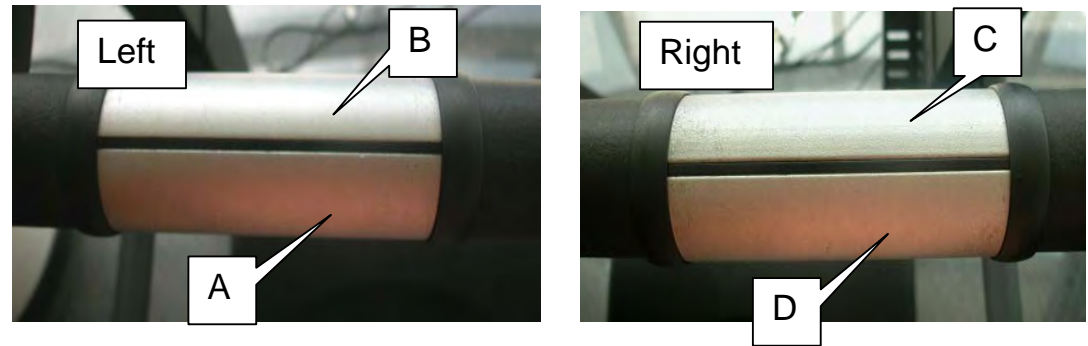

Fig. 2. Place black probe on points here.



### Continuity Test

a to A	Conductivity
b to B	Conductivity
c to C	Conductivity
d to D	Conductivity

### Short Test

GND to A	No Conductivity
GND to B	No Conductivity
GND to C	No Conductivity
GND to D	No Conductivity
GND to Frame	No Conductivity

Note: Around Oct. 2004, HTR handlebars changed. One contact plate was used on each side. The picture shows two plates, one on top, one on the bottom, on each side. Testing is similar, but two wires will be open – not conductive.

## 6300/6310 Treadmill Electronics Repair Manual – Troubleshooting

### **6300/6310 Troubleshooting**

ERR1.01 – ERR 1 – Motor Movement

ERR1.02 – Troubleshooting: ERR1 Motor Movement

ERR1.03 – ERR 1 – No Motor Movement

ERR1.04 – Troubleshooting: ERR1 Motor Movement

ERR3.01 – ERR 3

ERR3.02 – ERR 3 Troubleshooting

ERR7.01 – ERR7

ERR7.02 – ERR7 Troubleshooting

NO DISPLAY.01 – Display Does Not Light

NO DISPLAY.02 – Troubleshooting: Display Does Not Light



## 6300/6310 Treadmill Electronics Repair Manual – Troubleshooting

### ERR 1 – Motor Movement

ERR1 indicates a speed issue. In this case, the motor speed as reported from the optic sensor differs from the speed setting.

Analysis: Optic sensor signal issue -- Either the optic sensor signal is not right, or it is read incorrectly, or the signal is not reaching the display.

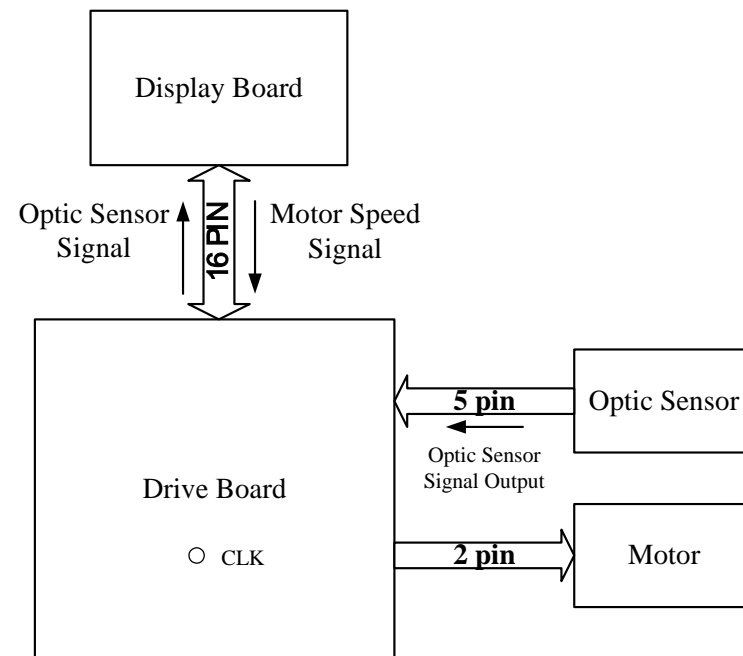

## 6300/6310 Treadmill Electronics Repair Manual – Troubleshooting

### **Troubleshooting: ERR1 – Motor Movement**

Since the motor moves when you press speed up, focus on the optic sensor, its wire connections, and the optic sensor wheel. If all seems well at the sensor, inspect the motor.

#### **Optic Sensor**

- Optic sensor wheel - Make sure that the optic sensor wheel rotates securely, without wobbling, in the middle of the optic sensor. Realign and tighten if necessary. If optic sensor wheel teeth are missing or bent, replace the optic sensor wheel.
- Optic sensor wires – Make sure that wires are inserted securely to the optic sensor and to the drive board. Check wire continuity.
- Optic sensor – Turn on unit power. Turn the motor flywheel with your hand. The optic sensor indicator (LED10, drive board) should light. See MOTOR.08. If it does not light, and all parts above are good, replace the optic sensor.

#### **Motor**

- Motor arcing – Does the motor show signs of wear – irregular arcing, carbon dust?
- Motor brushes – Do brushes show signs of irregular wear – cracks, dents, lines? Replace the motor brushes.
- M+ M- Wires - Make sure wires are connected properly.

#### **Other**

- Display main IC - To ensure proper signal processing, press down on the main IC on the display board, marked U5. See DISPLAY.06.
- Ribbon cable – Ensure that the ribbon cable is attached at the drive and display boards. Check cable continuity.

## 6300/6310 Treadmill Electronics Repair Manual – Troubleshooting

### ERR 1 – No Motor Movement

ERR1 indicates a speed issue. In this case, the motor does not operate when it should.

Analysis: Either the drive board is not putting out power to the motor, or the motor is malfunctioning.

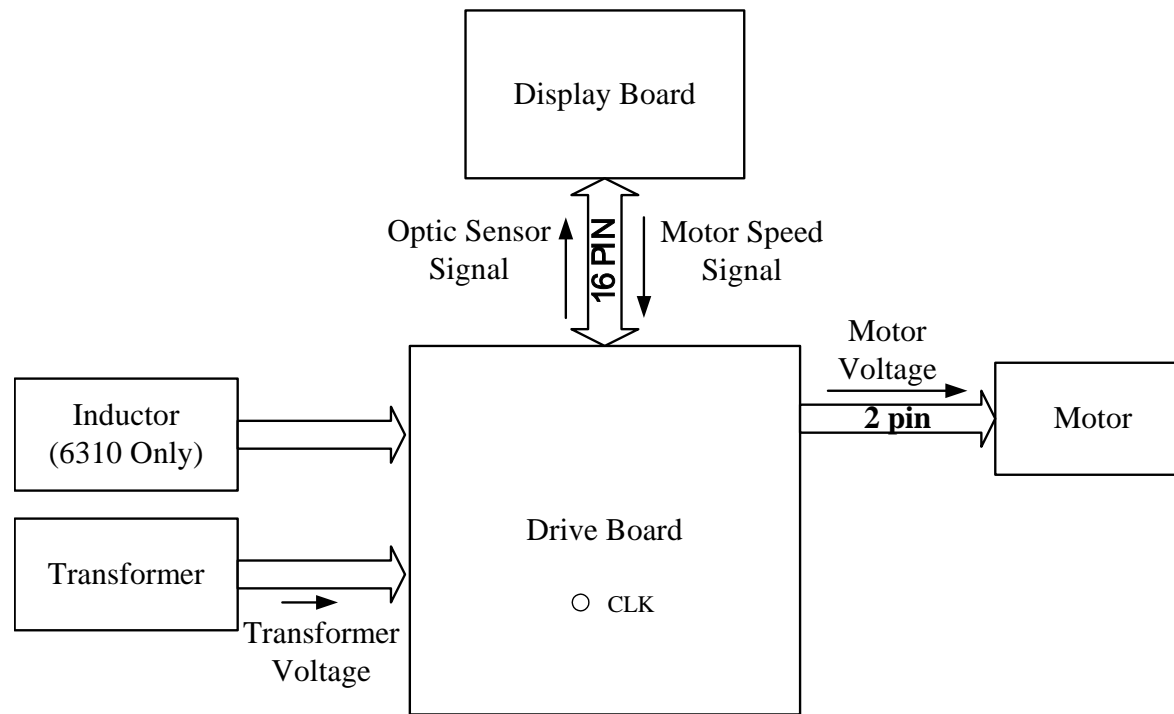

## 6300/6310 Treadmill Electronics Repair Manual – Troubleshooting

### **Troubleshooting: ERR 1 – No Motor Movement**

Turn unit power off and then on to clear the ERR1 message from the display. To test whether the drive board is putting out power to the motor, insert multimeter probes on the M+ M- connectors and press the speed up key. See MOTOR.02. (Note: To avoid ERR1 from immediately appearing, move the walk belt slowly with your feet.)

### **Power to Motor**

If the drive board puts out power to the motor, but the motor does not operate, either the motor wires or motor is malfunctioning. Test wires for continuity. Inspect connections. Perform an ohm test on the motor (see MOTOR.04). Inspect motor brushes.

### **No Power to Motor**

If there is no power to the motor, either the signal is not arriving at the drive board, the transformer or inductor is bad, or the drive board is bad. Inspect the following:

- Display – Does the display beep when you press speed up? If so, the display has sent its signal. If not, inspect overlay-to-display connections. And press down on the main program IC, marked U5.
- Wires and their connections – inspect data cable connections from the display to the drive board, test data cable continuity, inspect M+ M- wires from the drive board to the motor.
- Inductor (6310 only) – inspect inductor and its wires and their connections. See MOTOR.07.
- Transformer – inspect the transformer and its wires and their connections. See MOTOR.05.
- Drive Board – inspect the drive board for burnt or cracked components. Inspect LEDs (See DRIVE.03 and DRIVE.04). Press on the drive board IC chips to ensure good connection. If the power indicator on the drive board, LED8, lights, but there is no power to the motor, and other components are good, replace the drive board.

## 6300/6310 Treadmill Electronics Repair Manual – Troubleshooting

### ERR 3

ERR3 indicates that the actual unit speed differs from the speed setting. Unlike older SportsArt treadmills, though, ERR3 cannot be produced in 6300/6310 models by the user pulling the belt faster than the speed setting. Resolve an ERR3 issue much like you would an ERR1 with belt movement: check the optic sensor first. Other possible causes include a bad drive board motor circuit creating irregular power supply and a poorly connected main program IC.

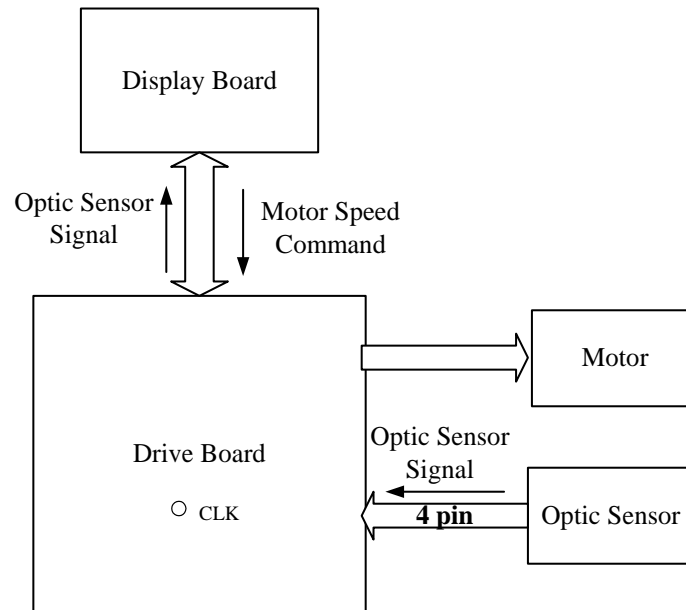

## 6300/6310 Treadmill Electronics Repair Manual – Troubleshooting

### **ERR 3 Troubleshooting**

Inspect the optic sensor and other components as follows.

#### **Optic Sensor**

- Optic sensor wheel – Make sure that the optic sensor wheel rotates securely, without wobbling, between the black optic sensor nubs. Realign and tighten if necessary. If optic sensor wheel teeth are missing or bent, replace the optic sensor wheel.
- Optic sensor wires – Check wire connections from the optic sensor to the drive board. Check wire continuity .
- Optic sensor – Turn on unit power. Turn the motor flywheel with your hand. The optic sensor indicator (LED10 on the drive board) should flicker. See MOTOR.08. If it does not light, and all parts above are OK, replace the optic sensor.

#### **Other**

- Motor – Does the motor sputter, sometimes running fast, sometimes slow? See MOTOR.04. If the motor tests good, replace the drive board. If the motor tests bad, replace it.
- Drive board – See above, and inspect for burnt, damaged, or loose components.
- Main program IC - Press down on the main program IC on the display to ensure a good connection. Replace the IC if necessary.

## 6300/6310 Treadmill Electronics Repair Manual – Troubleshooting

### ERR 7

Either the main program IC didn't detect the incline VR voltage, or the incline VR voltage exceeds the range setting.

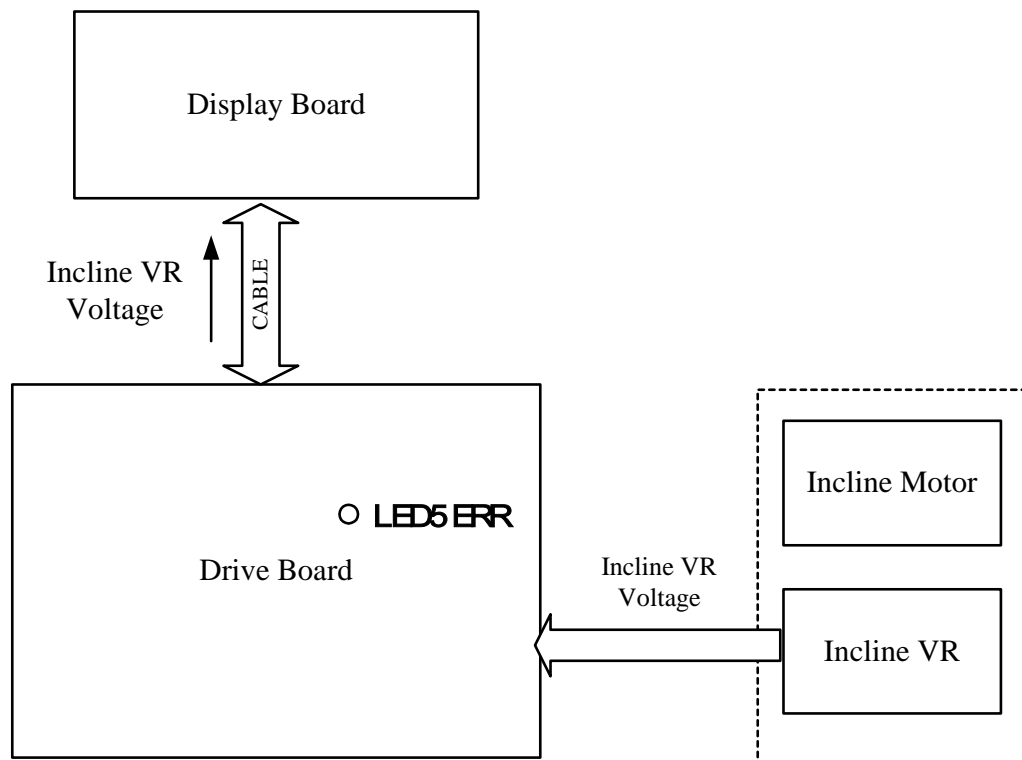

ERR7.01

## 6300/6310 Treadmill Electronics Repair Manual – Troubleshooting

### **ERR 7 Troubleshooting**

ERR7 is an incline system VR error. Check the incline VR first. Other possible causes include a bad data cable, drive board IC, and display IC. LED 5 on the drive board lights when the VR exceeds the set range.

#### **Incline System**

- Wire Connections – Make sure that CON4 and 5 connectors are fastened securely.
- Incline Set – If the incline pipe is stuck or overextended, recalibrate. See CALIBRATION.01.
- VR – Back-probe across the incline VR blue and green wires. Normal range: 1.1 to 4.0. Recalibrate the incline VR if values exceed this range. See CALIBRATION.01. If the VR will not calibrate, replace it.

#### **Other**

- Drive board – The drive board should supply 5 VDC power to the incline VR. Test by back-probing on the VR green and red wires. Also, press on drive board IC U20, marked 63DRV-1A, to ensure a good connection.
- Display board – Press on display board ICs U5 (main program) and U3 (ADC0804) to ensure good connections.
- Data cable – Inspect for broken or shorted wires. Perform continuity test on the cable.



## 6300/6310 Treadmill Electronics Repair Manual – Troubleshooting

### Display Does Not Light

Malfunction: Turn on unit power. Display does not beep once; display LEDs do not light.

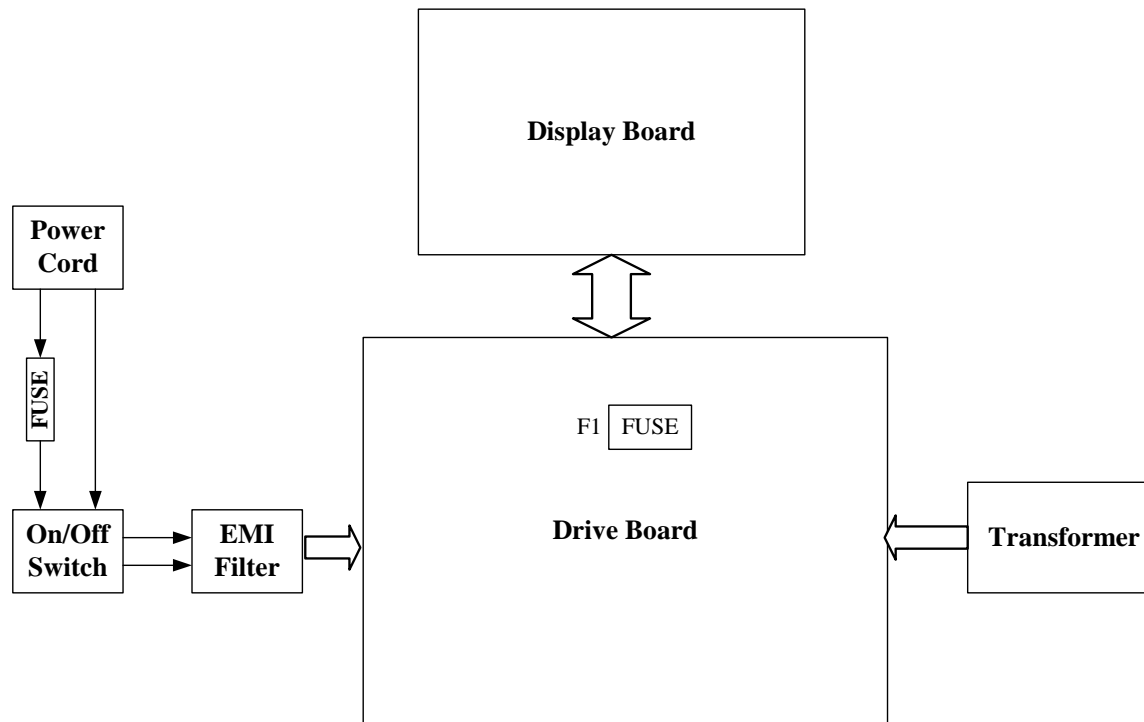

NO DISPLAY.01

## 6300/6310 Treadmill Electronics Repair Manual – Troubleshooting

### **Troubleshooting: Display Does Not Light**

Trace the power into the unit. The problem exists where the power desists.

- Power socket in the wall - Provides 110 to 120 VAC. If not, inspect the circuit breaker.
- Power cord – Make sure cord is plugged in properly. Inspect output.
- Fuse holder – Replace 15 Amp fuse if necessary. Inspect that power comes out of fuse holder.
- On/Off switch – Switch lights when “ON” and extinguishes when “OFF”. Inspect for output.
- EMI filter – Inspect for output by back-probing on AC1 and AC2 wires to the drive board.

Normal reading: 110 to 120 VAC.

- Transformer – Inspect for input and output. (See MOTOR.02.)
- Drive board – LED2 lights when drive board has power. (See DRIVE.03.) Test F1 3A fuse for continuity. (See DRIVE.05, lower left.) Make sure that wires, in particular CON3 and 4, are connected securely.
- Data cable – Make sure data cable is securely plugged into the display and drive boards. Test cable for continuity.
- Display – LED21 lights when display has power. (See DISPLAY.03.) Power to display can also be confirmed by probing on capacitors. Capacitor C26 voltage: 5 VDC. (See DISPLAY.04.) Capacitor C41 voltage: 14 VDC. (See DISPLAY.05.) (Electronic engineer replace U17 PW-8051.) Press down on main program IC U5 to ensure a good connection. (See DISPLAY.06.) Press down on LEDs to ensure a good connection.

## 6300/6310 Treadmill Electronics Repair Manual – Testing

### **Testing Components Unique to 6300/6310 Treadmills**

FILTER.01 – EMI Filter

FILTER.02 – EMI Filter Test

THERMAL FUSE.01 – Thermal Fuse Placement

THERMAL FUSE.02 – Thermal Fuse Operation

THERMAL FUSE.03 – Thermal Fuse Troubleshooting

EMERGENCY STOP.01 – Emergency Stop Signal Diagram, Emergency Stop Knob Operation

EMERGENCY STOP.02 – Emergency Stop Knob Troubleshooting, Emergency Stop Knob Test Configuration

EMERGENCY STOP.03 – Emergency Stop Revision

KEYS.01 – Key Operation, Key Test Configuration

KEYS.02 – Key Test Procedure

## 6300/6310 Treadmill Electronics Repair Manual – Testing

### EMI Filter

The EMI filter prevents interference to other electronic products. A malfunctioning filter would allow Interference to other product operation or possibly prevent voltage from arriving to the drive board.

### EMI Filter Test

Put the multimeter to the ohm setting. Place probes as shown below.

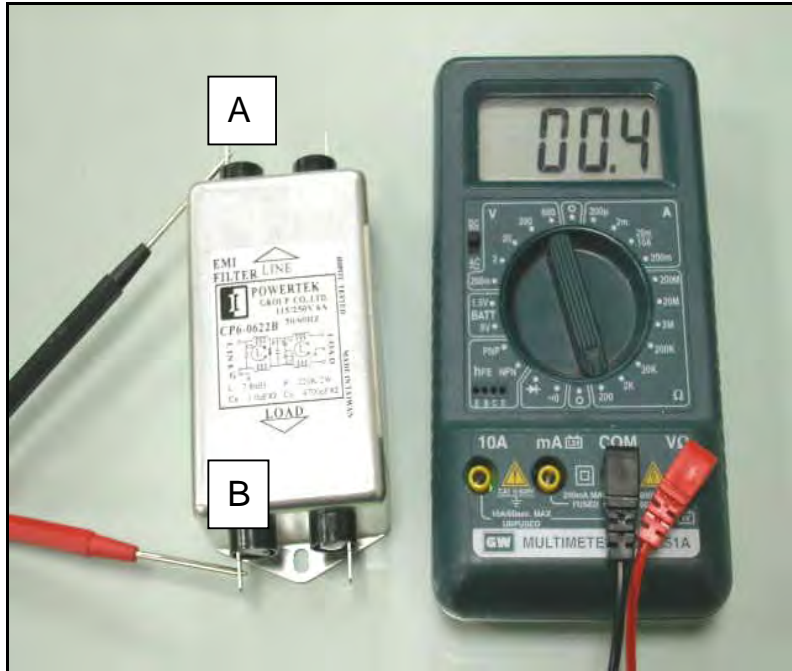

Test 1. Point A to Point B; Normal reading: 0.4 ohm.

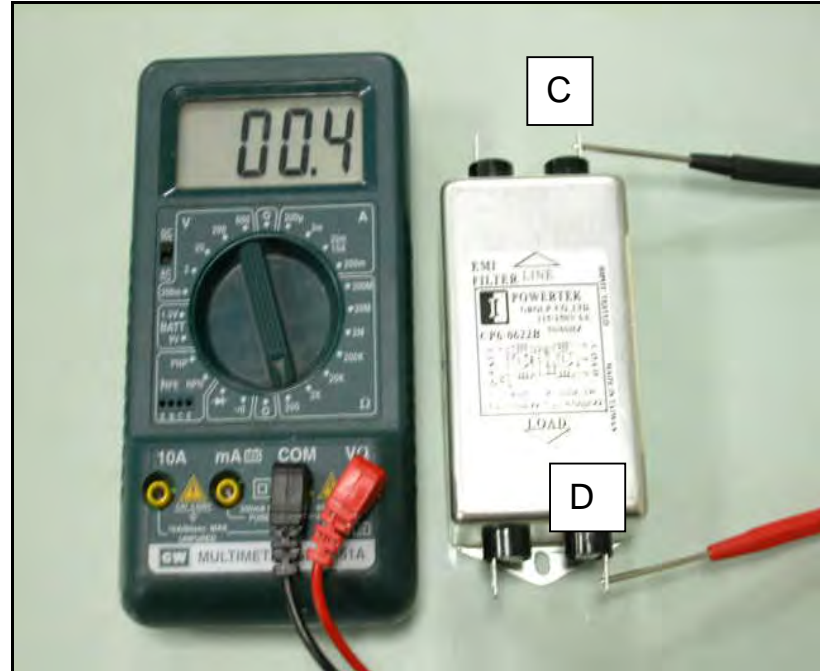

Test 2. Point C to Point D. Normal reading: 0.4 ohm.

## 6300/6310 Treadmill Electronics Repair Manual – Testing

### EMI Filter Test (Continued)

Put the multimeter to the ohm setting. Place probes as shown below.

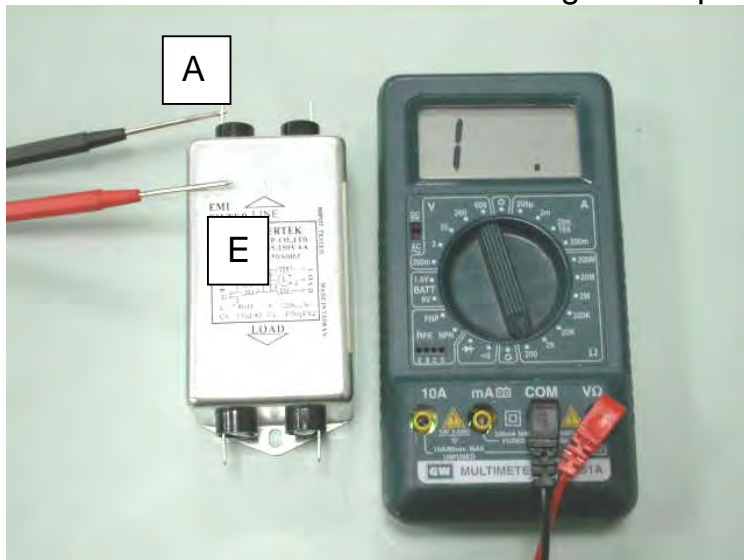

Test 3. Point A to Point E; Normal reading: No reaction (1 or OL).

Test Figure	Test Point	Normal Reading	Test Item
Fig. 1	A-B	0.4	There should be continuity between A and B
Fig. 2	C-D	0.4	There should be continuity between C and D
Fig. 3	A-E	1 or OL (open)	There should not be continuity between A and E; Continuity here indicates a short.

## Thermal Fuse Placement

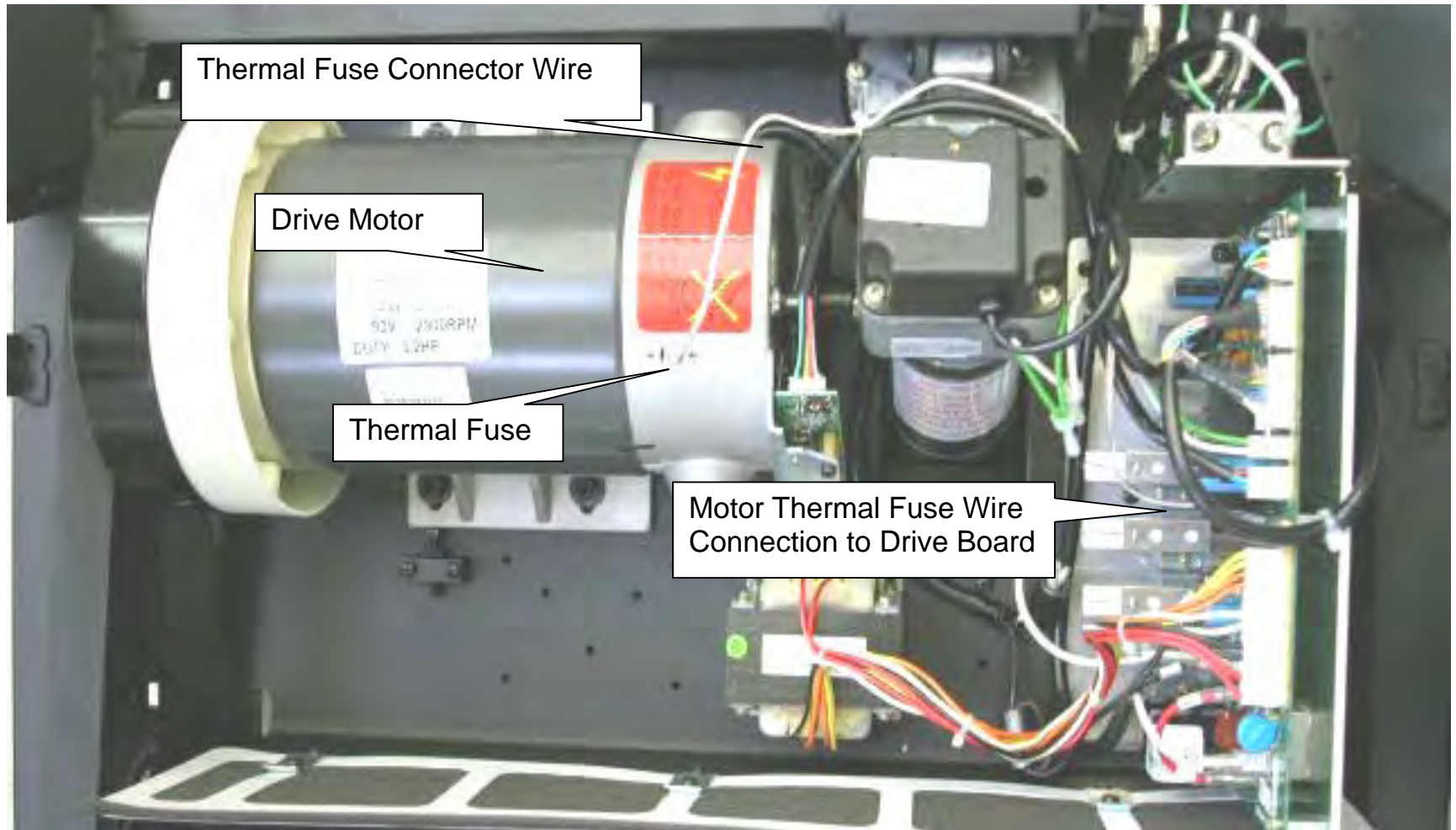

THERMAL FUSE.01

## 6300/6310 Treadmill Electronics Repair Manual – Testing

### Thermal Fuse Operation

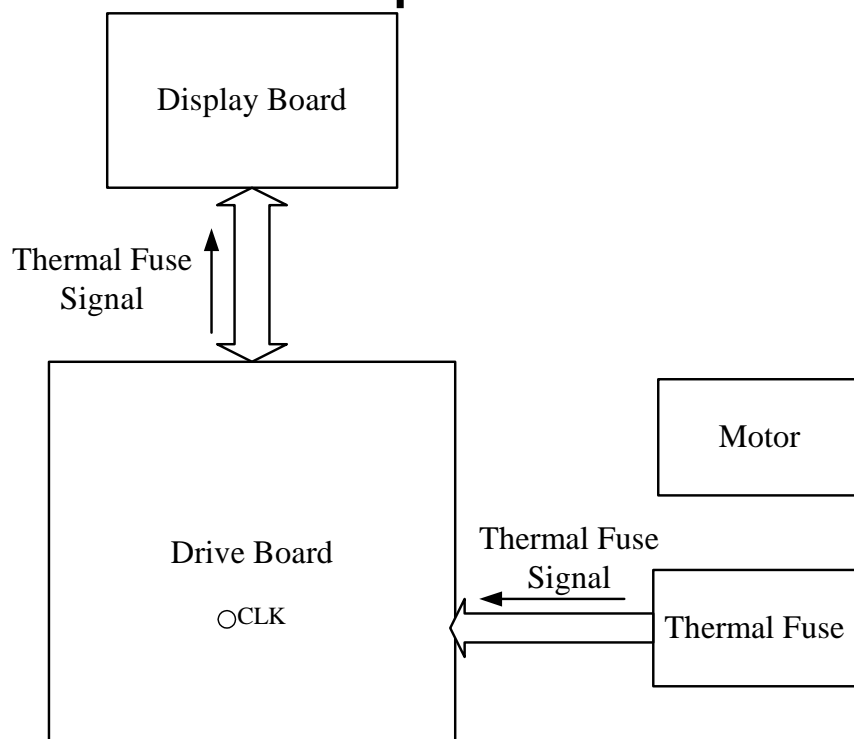

### Design Change Implementation

#### Model, Date, IC, Serial Number

6300, 03/30/04, M63T-4B, 0077981;  
6310, 04/27/04, B631H-4B, 0078117;  
6320, 0091593, B632H-4B, 0091593;

Information above marks the start of a thermal fuse operation design change. Before the change, the “Service Required” would light on the display after the thermal fuse was tripped. After the change, the motor would be shut down as well so the unit could not be used.

1. When the motor temperature gets too high, the thermal fuse “breaks,” cutting continuity to the thermal fuse circuit.
2. The break in continuity serves as a signal, which travels to the drive board then to the display.
3. The display main program IC reacts: “Service required” indicator lights on the display. On later units, the motor is shut off too. For details, see above right.

## 6300/6310 Treadmill Electronics Repair Manual – Testing

### **Thermal Fuse Troubleshooting**

If the “Service required” indicator lights, check the motor. Is it hot?

If the motor is not hot, and the indicator lights, check the fuse wire and its connections. Replace the thermal fuse if wires and connections are good but the indicator lights when the motor is cool.

If the motor is hot, inspect the deck and belt. Worn decks and belts produce friction, which causes the motor to draw more current and heat up. A walk belt that is too loose or too tight can cause more friction too. Replace belts and decks if necessary. The deck is two-sided and can be flipped.

After taking action, let the motor cool for 30 minutes before starting up again.



## 6300/6310 Treadmill Electronics Repair Manual – Testing

### Emergency Stop Knob Signal Diagram

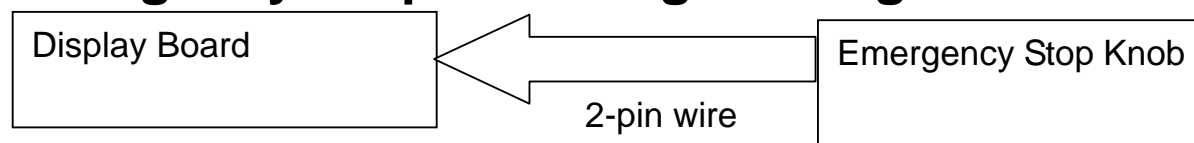

### Emergency Stop Knob Operation



Note: When not pressed down (left), the emergency stop knob circuit has continuity. When pressed down (right), the emergency stop knob circuit is an open line; there is no continuity.

1. While unit is in operation, press the emergency stop knob down. The circuit loses continuity. The display beeps once. Treadmill action stops. On 6300, the display main window shows: " \_ \_ \_ \_ ". On 6310, the display main window shows: "RESET EMERGENCY STOP BUTTON".
2. Rotate the emergency stop knob clockwise to reset. Emergency stop knob pops up. Circuit continuity is regained. Start up display appears.

## 6300/6310 Treadmill Electronics Repair Manual – Testing

### Emergency Stop Knob Troubleshooting

If the emergency stop knob malfunctions – activating when it shouldn't, or not activating when it should – inspect its wire connections, test wire continuity, and test the stop knob switch itself.

### Emergency Stop Knob Test Configuration

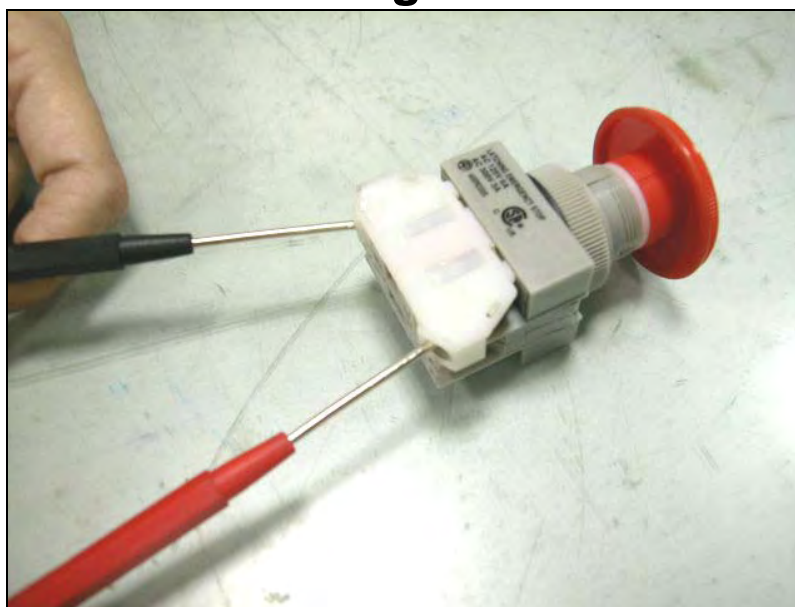

Test Procedure: Put multimeter to the Ohm setting. Place probes as shown. When the knob is not pressed down, the meter should read about 0.5 ohm (continuity). When the knob is pressed down, the meter should show no reaction, (open line), indicating no continuity. If your test results differ, replace the emergency stop knob.

## 6300/6310 Treadmill Electronics Repair Manual – Testing

### **Emergency Stop Knob Revision**

Treadmills made in and after September 2004 did not have the emergency stop knob. The knob was removed mainly because customers complained that end users didn't know how to operate it. There were also some complaints that hitting the knob damaged it, and the knob had to be replaced too often. Permanently removing the knob on old units requires two things: a jumper and a sticker. Both are available by contacting the SportsArt service department.

The procedure for eliminating the knob follows:

1. Leave the display attached to the display back – the long plastic piece that forms the bottle holders. But detach the display back from the unit. Then twist to detach the old stop knob from the display back. Take off the tape on the stop knob wires on the display back. Put the wires into the hole in the back of the display.
2. Secure the display back with one or two screws. Then detach the display. Unplug the knob wires from CON 8. Remove the wires. Place the jumper on the stop knob wire connector, CON 8 (See DISPLAY.03).
3. Secure the display and display back, putting in all the screws. Then place the sticker over the hole where the stop knob originally stood.

## 6300/6310 Treadmill Electronics Repair Manual – Testing

### Key Operation

Key circuits have continuity when keys are pressed down and don't have continuity when not pressed down. Key signals travel from the keypad via the wire connector to the display board. A sign of a possible key malfunction, (or a wire break or short) occurs when the treadmill acts as if a key has been pressed when no key was pressed, or the treadmill does not react when a key has been pressed.

### Key Test Configuration

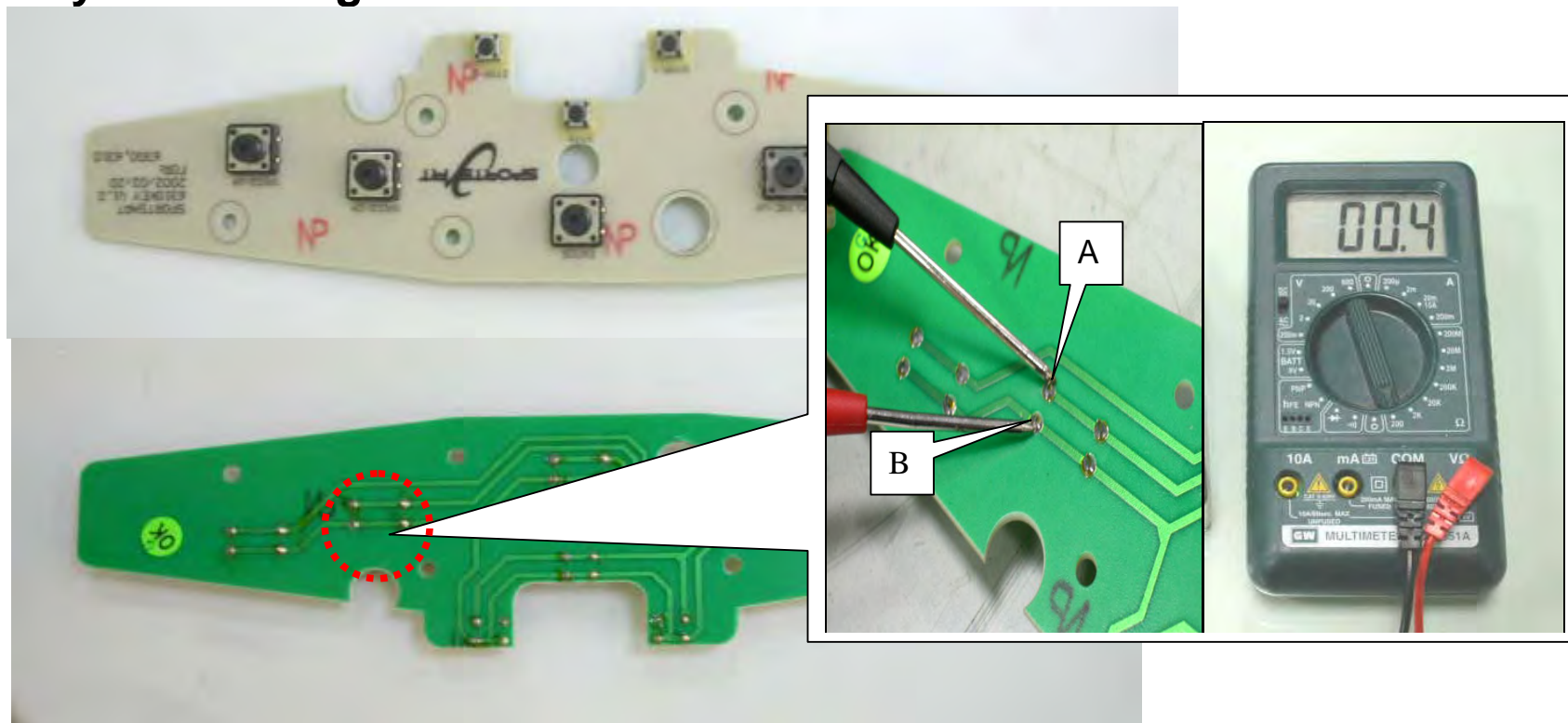

KEYS.01

## 6300/6310 Treadmill Electronics Repair Manual – Testing

### **Key Test Procedure**

Put multimeter to the ohm setting. Place probes as shown on points A and B.  
Normal reading when key is not pressed down: no reaction, OL or I (open line).  
Normal reading when key is pressed down: 0.4 ohm.

Other keys can be tested similarly.

## 6300/6310 Treadmill Electronics Repair Manual – Reference

### **Reference**

REF.01 – 6300/6310 Drive Board LED Reference Chart

REF.02 – 6300/6310 Display LED Reference Chart, 6300/6310 Fuse Reference Chart

REF.03 – VR Voltages for Various SportsArt Treadmill DC Incline Motors

## 6300/6310 Treadmill Electronics Repair Manual – Reference

### 6300/6310 Drive Board LED Reference Chart

LED	Position	Color	Name	Action
1	Mid left, high	Red	Power	Lights when power switch is on; extinguishes when power switch is turned off or when the emergency knob is pressed. Relights when emergency knob is reset.
2	Left top	Green	VCC power	Lights when power switch is on. Indicates that drive board VCC circuit is operating; power is being sent to display.
3	Mid left high	Green	Incline Down	Lights when incline operates down. Indicates that the display incline down signal has arrived at the drive board and the drive board is putting out power to the incline motor.
4	Mid left, under 3	Green	Incline Up	Lights when incline operates up. Indicates that the display incline up signal has arrived at the drive board and the drive board is putting out power to the incline motor.
5	Mid left, center	Red	Incline Error	Lights to indicate that the incline is overextended. Recalibration is necessary.
6	Mid left, under 1	Red	“SOFT” Check	Immediately after the unit is turned on, the “SOFT” circuit shuts off motor power to prevent uncontrolled motor action. The “SOFT” LED lights two seconds after power switch is turned on; extinguishes when power switch is turned off or when the emergency knob is pressed. Relights when emergency knob is reset.
7	Mid right, low	Green	High Amp	Lights when drive board current restriction circuit is activated. This occurs when the amp draw is too high. Inspect the motor, walk belt, deck. This LED is not lit under normal circumstances.
8	Mid right, low, by 7	Red	IGBT Short	Lights when the IGBT has shorted. This LED is not lit under normal circumstances. If it lights, replace the drive board.
9	Mid right, low, by 7	Red	Belt Pull	Lights normally. Turns off if belt is pulled faster than speed setting.
10	Right low	Green	Optic Sensor	Lights when the optic sensor signal enters the drive board. Flickers at low speeds; remains lit at high speeds. If it does not light when the motor flywheel moves, inspect the optic sensor, optic sensor wheel, and related wires.

Note: Positions are described as if you are looking at a drive board installed in the unit. Cable connectors are on top. The L-shaped aluminum plate is on the bottom. The left side has a row of ICs. Two large, black capacitors are on bottom right.

## 6300/6310 Treadmill Electronics Repair Manual – Reference

### 6300/6310 Display LED Reference Chart

LED	Position	Color	Name	Action
LED 20	Top right	Red	C-Safe	Lights to indicate that the display is supplying 5 VDC for C-SAFE operation. LED lights regardless of whether C-SAFE power is actually being used.
LED 21	Lower left	Green	Power	Lights to indicate that the display is receiving power from the drive board, via the ribbon cable.

### 6300/6310 Fuse Reference Chart

FUSE	Position	Fuse Specifications	If fuse breaks, install a new one of the same type and inspect the following:
Main Fuse	On frame, near power switch	15A 250V (6x32mm) Slow	Fuse holder, On/Off switch, AC1, AC2 wiring, drive board, motor.
Fuse 1: Drive Board Power	On drive board, under CON1	3A 250V (5x20mm) Fast	Transformer, drive board.
Fuse 2: Incline	On drive board, under CON5	3A 250V (5x20mm) Fast	Incline motor, incline motor wiring.



## 6300/6310 Treadmill Electronics Repair Manual – Reference

### VR Voltages for Various SportsArt Treadmill DC Incline Motors

Model	Incline Position		Incline VR Range (Blue & Green)	
	Low	VR Voltage Blue & Green Wires	High	VR Voltage Blue & Green Wires
1210	0%	1.20 VDC	12%	3.30 VDC
3100/3120/3150	0%	3.55 VDC	15%	1.20 VDC
3106/3108/3110	0%	1.20 VDC	15%	3.80 VDC
3200/3250	0%	1.20 VDC	15%	3.55 VDC
6100/6150	0%	3.55 VDC	15%	1.20 VDC
6100E/6150E	0%	1.20 VDC	15%	3.55 VDC
6200/6200N/6260	-3%	1.20 VDC	22%	3.55 VDC
6300/6310	0%	1.20 VDC	15%	3.80 VDC
6320	-3%	1.20 VDC	22%	3.80 VDC

### Action of Various SportsArt Treadmill DC Incline Motors

Model	Incline Method	Incline Position	
		Lowest = 0%	Highest = 15%
3100/3120/3150	Pull In	Longest	Shortest
1210/3106/3108/3110	Push Out	Shortest	Longest
3200/3250	Push Out	Shortest	Longest
6100/6150	Push Out	Shortest	Longest
6100E/6150E	Pull In	Longest	Shortest
6200/6200N/6260	Push Out	Shortest	Longest
6300/6310/6320	Push Out	Shortest	Longest