

USER'S MANUAL

# SMOOTH 9.25X MOTORIZED TREADMILL

MODEL NUMBER: 9.25X

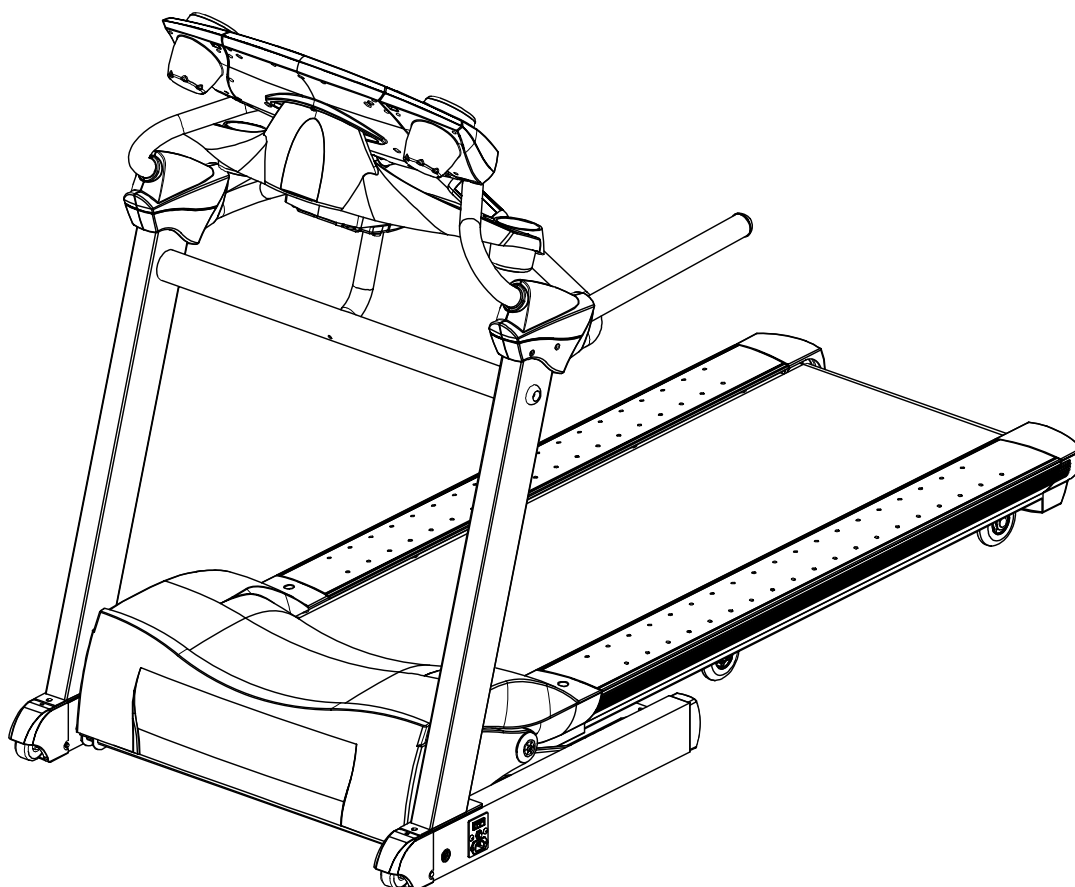

USER WEIGHT LIMITATION: **400lbs. (180kgs)**

TOLL FREE CUSTOMER SERVICE NUMBER: **1.888.800.1167**

SERIAL NUMBER (found on frame):



## PRECAUTIONS

### For future service or related questions:

Please staple your receipt and/or write in the name and phone number of the retail store where you purchased your Smooth Fitness treadmill.

Name: \_\_\_\_\_ Phone Number: \_\_\_\_\_ Receipt: \_\_\_\_\_

### Precautions:

**WARNING:** To reduce the risk of burns, fire, electric shock, or injury to persons, read the following important precautions and information before operating the treadmill. It is the responsibility of the owner to ensure that all users of this treadmill are adequately informed of all warnings and precautions.

- Use the treadmill only as described in this manual.
- Place on a level surface, with 6 feet (2 m) of clearance behind it. Do not place the treadmill on any surface that blocks air openings. To protect the floor or carpet from damage, place a mat under the treadmill.
- When choosing a location for the treadmill make sure that the location and position permit access to a plug.
- Keep the treadmill indoors, away from moisture and dust. Do not put the treadmill in a garage or covered patio, or near water.
- Do not operate the treadmill where aerosol products are used or where oxygen is being administered.
- Keep children under the age of 12 and pets away from the treadmill at all times.
- The treadmill should not be used by persons weighing more than 400lbs (180kgs).
- Never allow more than one person on the treadmill at a time. Wear appropriate exercise clothing when using the treadmill. Do not wear loose clothing that could become caught in the treadmill. Athletic support clothes are recommended for both men and women. Always wear athletic shoes. Never use the treadmill with bare feet, wearing only stockings, or in sandals.
- When connecting the power cord, plug the power cord into a grounded circuit. No other appliance should be on the same circuit.
- Always straddle the belt and allow it to start moving before stepping onto the belt.
- Always examine your treadmill before using to ensure all parts are in working order.
- Allow the belt to fully stop before dismounting.
- Never insert any object or body parts into any opening.
- Follow the safety information in regards to plugging in your treadmill.
- Keep the power cord away from the incline wheels and do not run the power cord underneath your treadmill. Do not operate the treadmill with a damaged or frayed power cord.
- Always unplug the treadmill before cleaning and/or servicing. Service to your treadmill should only be performed by an authorized service representative, unless authorized and/or instructed by the manufacturer. Failure to follow these instructions will void the treadmill warranty.
- Never leave the treadmill unattended while it is running.

## POWER REQUIREMENTS

### Power Requirements:

IMPROPER CONNECTION OF THE EQUIPMENT GROUNDING CONNECTOR CAN RESULT IN A RISK OF AN ELECTRIC SHOCK. CHECK WITH A QUALIFIED ELECTRICIAN OR SERVICE MAN IF YOU ARE IN DOUBT AS TO WHETHER THE PRODUCT IS PROPERLY GROUNDING. DO NOT MODIFY THE PLUG PROVIDED WITH THE PRODUCT, IF IT WILL NOT FIT THE OUTLET; HAVE A PROPER OUTLET INSTALLED BY A QUALIFIED ELECTRICIAN.

This treadmill can be seriously damaged by sudden voltage changes in your home's electrical power. Voltage spikes, surges and noise interference can result from weather conditions or from other appliances being turned on or off. To reduce the possibility of treadmill damage, always use a surge protector (not included) with your treadmill.

Surge protectors can be purchased at most hardware stores. The manufacturer recommends a single outlet surge protector with a UL 1449 rating as a Transient Voltage Surge Suppressor (TVSS) with a UL suppressed voltage rating of 400V or less and an electrical rating 120VAC, 15 amps.

This treadmill must be grounded to reduce the risk of electrical shock. Grounding provides a path of least resistance for electric current, should the treadmill malfunction. This treadmill comes with an electrical cord having an equipment-grounding conductor and a grounding plug. Always plug the power cord into a surge protector, and plug the surge protector into an appropriate outlet that is properly installed and grounded in accordance with all local codes and ordinances.

This product is for use on a nominal 120-volt circuit, and has a grounding plug that looks like the plug illustrated in the drawing below.

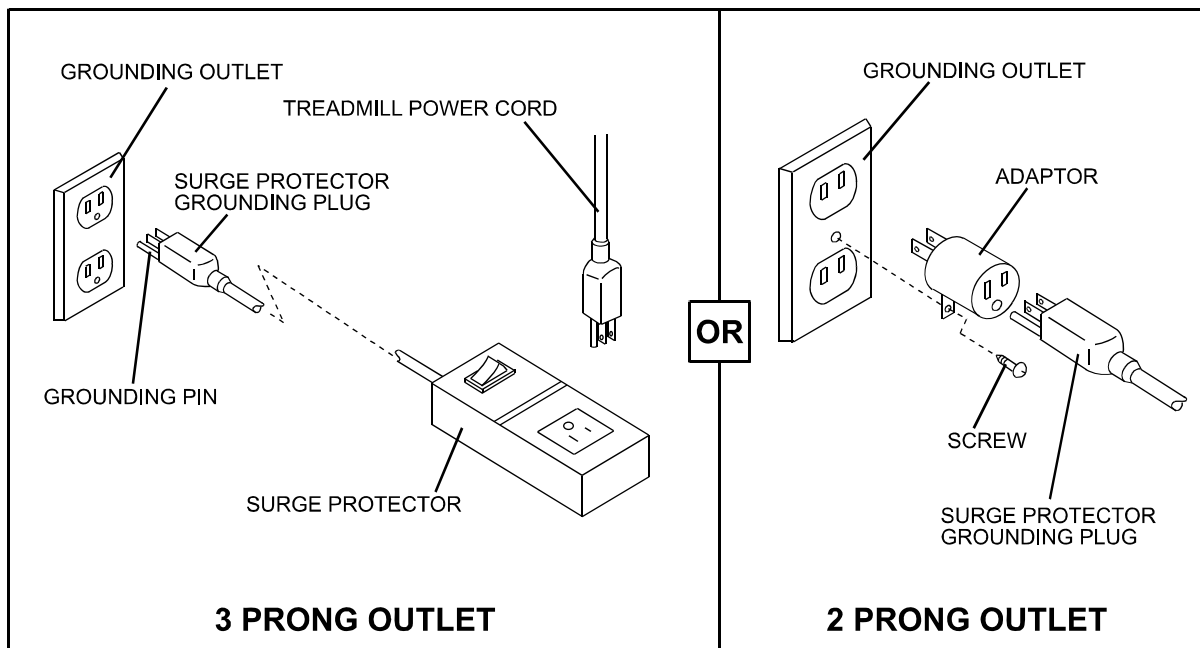

## PREASSEMBLY

### **Open the boxes:**

You are now ready to open the boxes of your new equipment. Make sure to inventory all of the parts that are included in the boxes. Check the Hardware Comparison Chart for a full count of the number of parts included for this product to be assembled properly. If you are missing any parts or have any assembly questions call your local Smooth Retailer.

### **Gather your tools:**

Before starting the assembly of your unit, make sure that you have gathered all the necessary tools you may require to assemble the unit properly. Having all of the necessary equipment at hand will save time and make the assembly quick and hassle-free.

### **Clear your work area:**

Make sure that you have cleared away a large enough space to properly assemble the unit. Make sure the space is free from anything that may cause injury during assembly. After the unit is fully assembled, make sure there is a comfortable amount of free area around the unit for unobstructed operation.

### **Invite a friend:**

Some of the assembly steps may require heavy lifting. It is recommended that you obtain the assistance of another person when assembling this product.

### **User Weight Limitation:**

Please note that there is a weight limitation for this product. **If you weigh more than 400lbs. (180kgs) it is not recommended that you use this product. Serious injury may occur if the user's weight exceeds the limit shown here.** This product is not intended to support users whose weight exceeds this limit.

**HARDWARE COMPARISON CHART**

**Hardware chart:**

For your convenience, we have identified the hardware used in the assembly of this product. This chart is provided to help you identify those items that may be unfamiliar to you.

NO.	DESCRIPTION	QTY.
9	Console Support Fixing Plate	2
11	M6 x 15mm Screw	4
16	#8 x 25mm Screw	8
17	Handlebar Fixing Plate	2
18	M8 x 50mm Allen Head Bolt	6
19	M8 x 15mm Allen Head Bolt	4
A	Wrench	1
B	Screw Driver	1
C	Allen Wrench	1

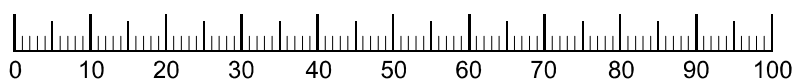
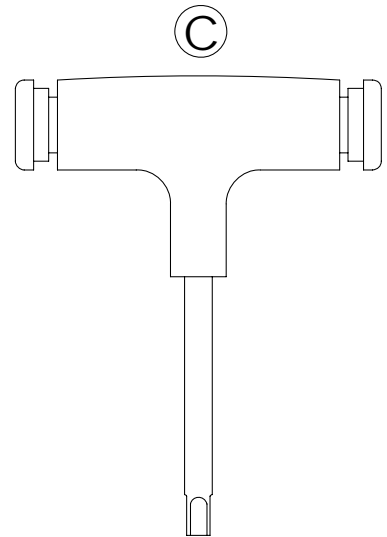
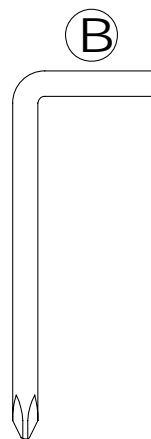
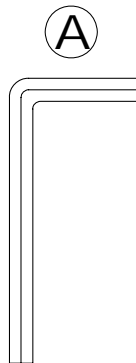
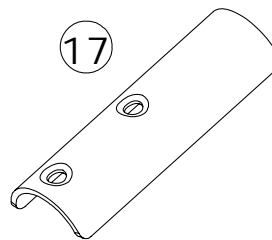
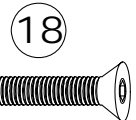
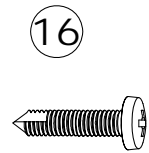
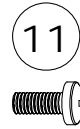
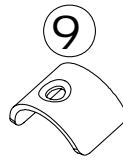

MILLIMETERS

## SMOOTH 9.25X MOTORIZED TREADMILL

PARTS LIST

No.	Description	Qty.	Order No.	No.	Description	Qty.	Order No.
1	Computer	1	9.25X-01	31	Console Tray Support Tube	1	9.25X-31
2	Console Housing- Upper	1	9.25X-02	32	Upright Cross Brace	1	9.25X-32
3	Console Housing- Bottom	1	9.25X -03	33	M8 x 25mm Console Tray Support Tube Bolt	1	9.25X-33
4	Rubber Insert	4	9.25X-04	34	Handlebar-Right	1	9.25X-34
5	Rubber Cap for Audio Input	2	9.25X-05	35	Front Handlebar	1	9.25X-35
6	Safety Key	1	9.25X-06	36	Upright-Right	1	9.25X-36
7	Console Support Tube	1	9.25X-07	37	#8 x 15mm Drill Screw	51	9.25X-37
8	#8 x 10mm Console Housing Screw	11	9.25X-08	38	Elevation Motor Cover Board	1	9.25X-38
9	Console Support Tube Fixing Plate	2	9.25X-09	39	Power Cord	1	9.25X-39
10	#8 x 19mm Computer Screw	5	9.15X-10	40	M6 x 15mm Bolt for Power Plate	2	9.25X-40
11	M6 x 15mm Screw	2	9.25X-11	41	N/A		N/A
12	Handlebar Cover- Left #1	1	9.25X-12	42	Power Plate	1	9.25X-42
13	Handlebar Cover- Left #2	1	9.25X-13	43	N/A	N/A	N/A
14	Handlebar Cover- Right #2	1	9.25X-14	44	N/A	N/A	N/A
15	Handlebar Cover-Right #1	1	9.2X-15	45	Transport Wheel Shaft	2	9.25X-45
16	#8 x 25mm Screw	10	9.25X-16	46	M14 x 90mm Bolt	2	9.25X-46
17	Handlebar Fixing Plate	2	9.25X-17	47	Wire Clip	1	9.25X-47
18	M8 x 50mm Allen Head Bolt	6	9.25X-18	48	Base Frame End Cap	2	9.25X-48
19	M8 x 15mm Allen Head Screw	4	9.25X-19	49	Elevation Motor	1	9.25X-49
20	#8 x 10mm Screw	3	9.25X-20	50	Cir-Clip	2	9.25X-50
21	Console Tray Fixing Plate	1	9.25X-21	51	Transport Wheel	2	9.25X-51
22	Console Tray	1	9.25X-22	52	5/16" x 10mm Screw	4	9.25X-52
23	Console Tray Cover	1	9.25X-23	53	16 x 10mm Spring Washer	1	9.25X-53
24	Handlebar-Left	1	9.25X-24	54	M10 x 35mm Bolt	1	9.25X-54
25	Handlebar Grip	2	9.25X-25	55	Base Frame	1	9.25X-55
26	EKG Pulse Sensor	2	9.25X-26	56	Diving Tube	1	9.25X-56
27	Handlebar End Cap	2	9.25X-27	57	Micro Switch	2	9.25X-57
28	Upright Cross Brace Bolt	2	9.25X-28	58	Level Adjuster	4	9.25X-58
29	Metal Cap	2	9.25X-29	59	Fold Up Position Limiting Rod	1	9.25X-59
30	Upright-Left	1	9.25X-30	60	Fold Up Slipping Rod Sleeve	2	9.25X-60

## SMOOTH 9.25X MOTORIZED TREADMILL

PARTS LIST

No.	Description	Qty.	Order No.	No.	Description	Qty.	Order No.
61	Position Limiter	2	9.25X-61	91	Cir-Clip	2	9.25X-91
62	Fold Up Slipping Rod	2	9.25X-62	92	12 x 34.5mm Shaft	2	9.25X-92
63	Wheel Support	1	9.25X-63	93	M14 x 53mm Bolt	2	9.25X-93
64	M8 x 40mm Bolt	2	9.25X-64	94	Copper Bushing-#1	4	9.25X-94
65	PU Wheel	4	9.25X-65	95	Elevation Support Frame-#2	2	9.25X-95
66	Motor Bottom Tray	1	9.25X-66	96	M14 x 62mm Bolt	2	9.25X-96
67	Motor Hood	1	9.25X-67	97	Plastic Cap	2	9.25X-97
68	M4 x 25mm Motor Hood Screw	2	9.25X-68	98	Copper Bushing-#2	4	9.25X-98
69	13 x 6.5mm Washer	13	9.25X-69	99	#6202 Bearing	2	9.25X-99
70	M5 x 12mm Screw	2	9.25X-70	100	Transformer-Controller	1	9.25X-100
71	Side Rail Non-Slip Sticker-Left	1	9.25X-71	101	Motor Control Board	1	9.25X-101
72	Side Rail Non-Slip Sticker-Right	1	9.25X-72	102	Elevation Control Board	1	9.25X-102
73	Side Rail-Right	1	9.25X-73	103	Motor Hood Fixing Bracket	2	9.25X-103
74	Side Rail-Left	1	9.25X-74	104	Transformer - Audio	1	9.25X-104
75	Deck End Cap-Left	1	9.25X-75	105	M5 Nut	1	9.25X-105
76	Deck End Cap-Right	1	9.25X-76	106	M5 x 10mm Phillip Head Screw	1	9.25X-106
77	M8 x 25mm Deck Fixing Bolt	10	9.25X-77	107	N/A	N/A	N/A
78	Deck Grounding Metal Sheet-Upper	2	9.25X-78	108	N/A	N/A	N/A
79	#8 x 10mm Wood Screw	7	9.25X-79	109	Deck Frame	1	9.25X-109
80	Running Deck	1	9.25X-80	110	N/A	N/A	N/A
81	Front Roller Shaft	1	9.25X-81	111	Deck Rubber Cushion	10	9.25X-111
82	Front Roller	1	9.25X-82	112	Side Rail Guide Block	8	9.25X-112
83	Roller Pulley	1	9.25X-83	113	M10 x 16mm Bolt	8	9.25X-113
84	Running Belt	1	9.25X-84	114	M6 x 70mm Roller Adjuster Bolt	3	9.25X-114
85	Rear Roller Shaft	1	9.25X-85	115	M8 Nut	10	9.25X-115
86	Rear Roller	1	9.25X-86	116	15 x 8mm Spring Washer	12	9.25X-116
87	Front Shroud	1	9.25X-87	117	Board Clip	5	9.25X-117
88	M5 x 20mm Allen Head Screw	2	9.25X-88	118	Metal Clip	1	9.25X-118
89	Round Cap	2	9.25X-89	119	Wheel Shaft	2	9.25X-119
90	Elevation Support Frame-#1	1	9.25X-90	120	M8 Nylon Nut	3	9.25X-120

## SMOOTH 9.25X MOTORIZED TREADMILL

PARTS LIST

No.	Description	Qty.	Order No.	No.	Description	Qty.	Order No.
121	Running Deck Belly Pan	1	9.25X-121	151	N/A	N/A	N/A
122	Deck Frame Rubber Cushion	2	9.25X-122	152	Rubber Dot	2sets	9.25X-152
123	Motor Belly Pan	1	9.25X-123	153	EKG Pulse Sensor Wire	2	9.25X-153
124	Driving DC Motor	1	9.25X-124	154	EKG Pulse Sensor Wire – Upper Section	2	9.25X-154
125	Motor Holder	1	9.25X-125	155	Transport Wheel Cover	2	9.25X-155
126	M8 x 87mm Motor Holder Bolt	1	9.25X-126				
127	30 x 8mm Washer	2	9.25X-127				
128	PU Cushion	1	9.25X-128				
129	M8 x 15mm Motor Fixing Bolt	2	9.25X-129				
130	16 x 8mm Washer	2	9.25X-130				
131	M10 Nylon Nut	1	9.25X-131				
132	22 x 10mm Washer	1	9.25X-132				
133	M10 x 188mm Bolt	1	9.25X-133				
134	Driving Belt	1	9.25X-134				
135	Bracket Screw	1	9.25X-135				
136	N/A	N/A	N/A				
137	Plastic Fixing Insert	6	9.25X-137				
138	Wire Loom-Upper Section	1	9.25X-138				
139	Safety Key Power Wire-Upper Section	1	9.25X-139				
140	Audio System Power Wire – Upper Section	1	9.25X-140				
141	Audio System Power Wire – Bottom Section	1	9.25X-141				
142	Safety Key Power Wire-Bottom Section	1	9.25X-142				
143	Wire Loom- Bottom Section	1	9.25X-143				
144	Power Switch	1	9.25X-144				
145	Non-Fuse Breaker Switch	1	9.25X-145				
146	Power Socket	1	9.25X-146				
147	Water Bottle	1	9.25X-147				
148	Heart Rate Transmitter Belt	1	9.25X-148				
149	Speaker – Right	1	9.25X-149				
150	Speaker – Left	1	9.25X-150				



PARTS DIAGRAM

A MAJORITY OF THE PARTS SHOWN HERE HAVE BEEN PREASSEMBLED AT THE FACTORY.

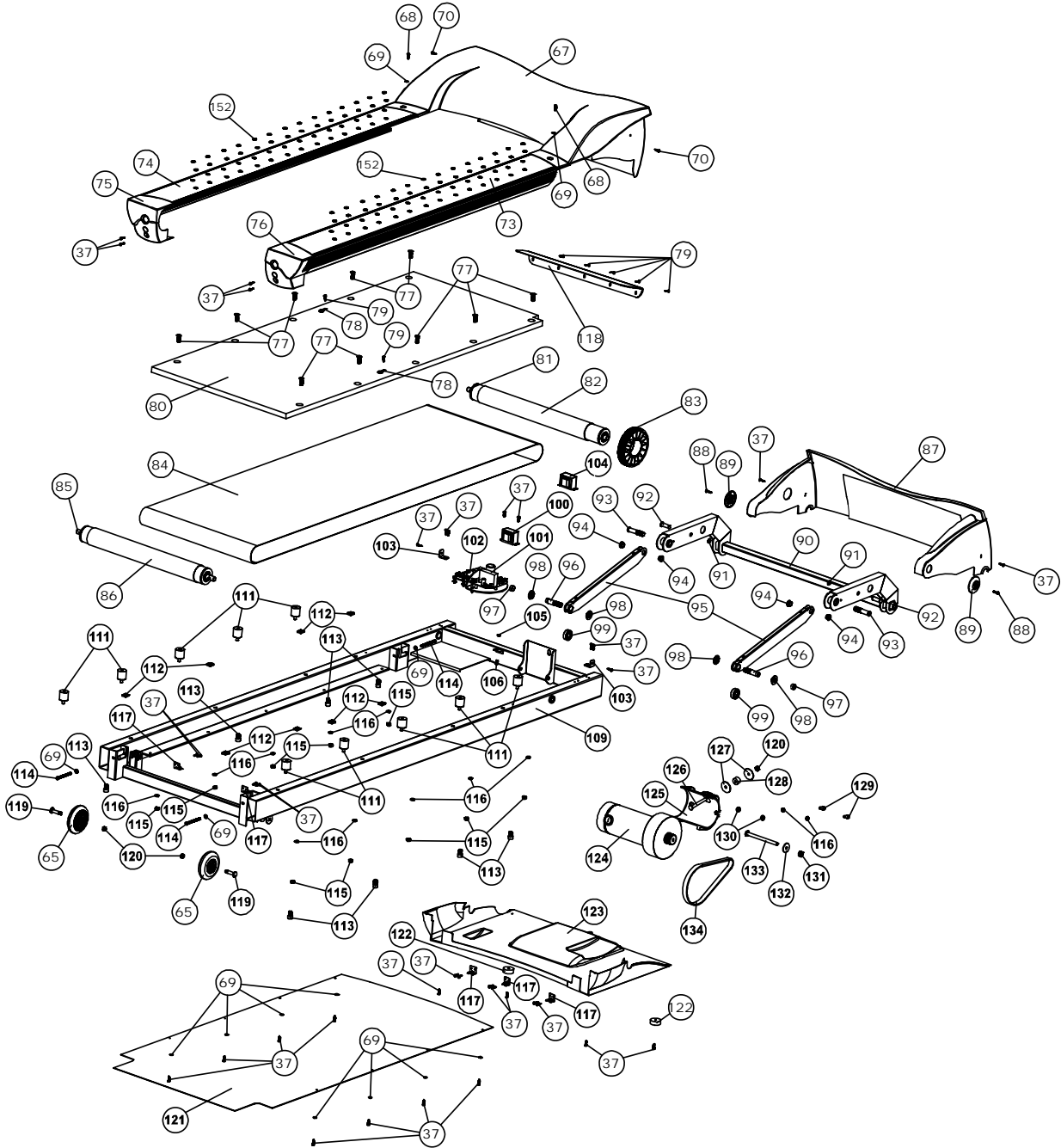

## SMOOTH 9.25X MOTORIZED TREADMILL

## PARTS DIAGRAM

A MAJORITY OF THE PARTS SHOWN HERE HAVE BEEN PREASSEMBLED AT THE FACTORY.

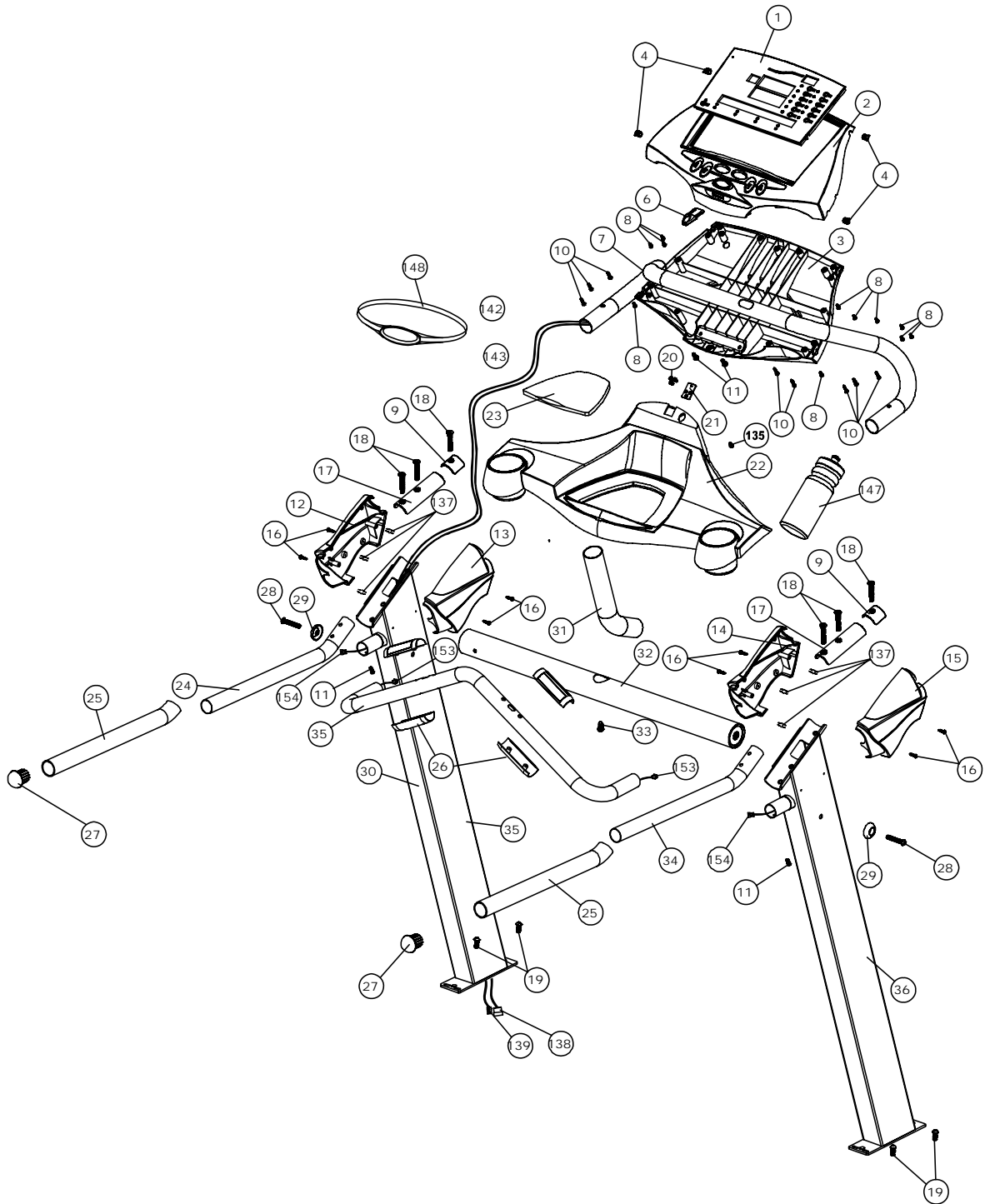

## PARTS DIAGRAM

A MAJORITY OF THE PARTS SHOWN HERE HAVE BEEN PREASSEMBLED AT THE FACTORY.

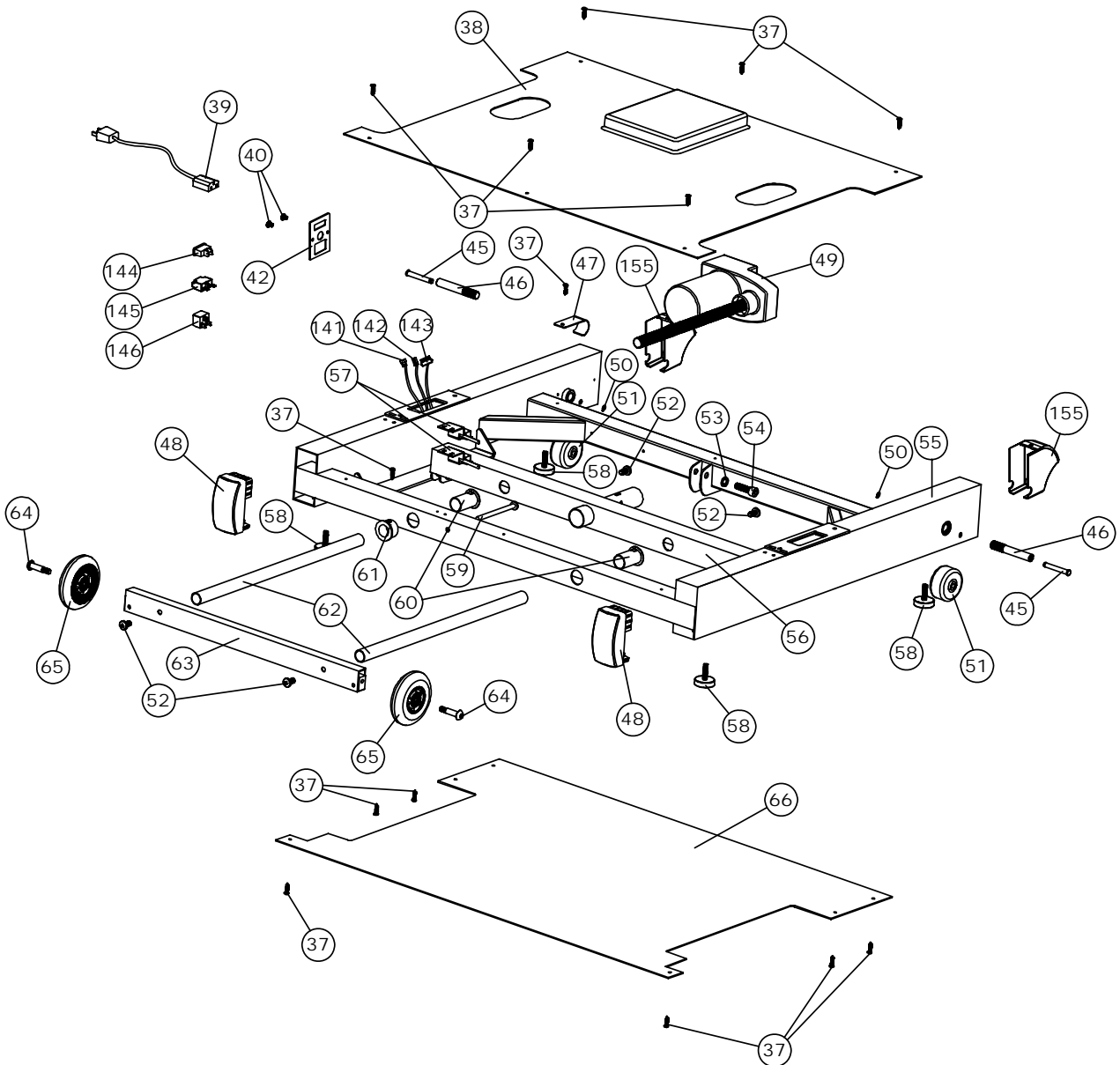

ASSEMBLY**STEP 1:**

Remove your treadmill from the carton and place it on the floor in an open area as shown in FIG 1.

Then remove the Handlebars and place them out of the way for now, as shown in FIG2.

Attach the Console Support Tube (7) to Upright – Left (30) and Upright – Right (36) with Console Support Tube Fixing Plate (9) and M8 x 50mm Allen Head Bolt (18).

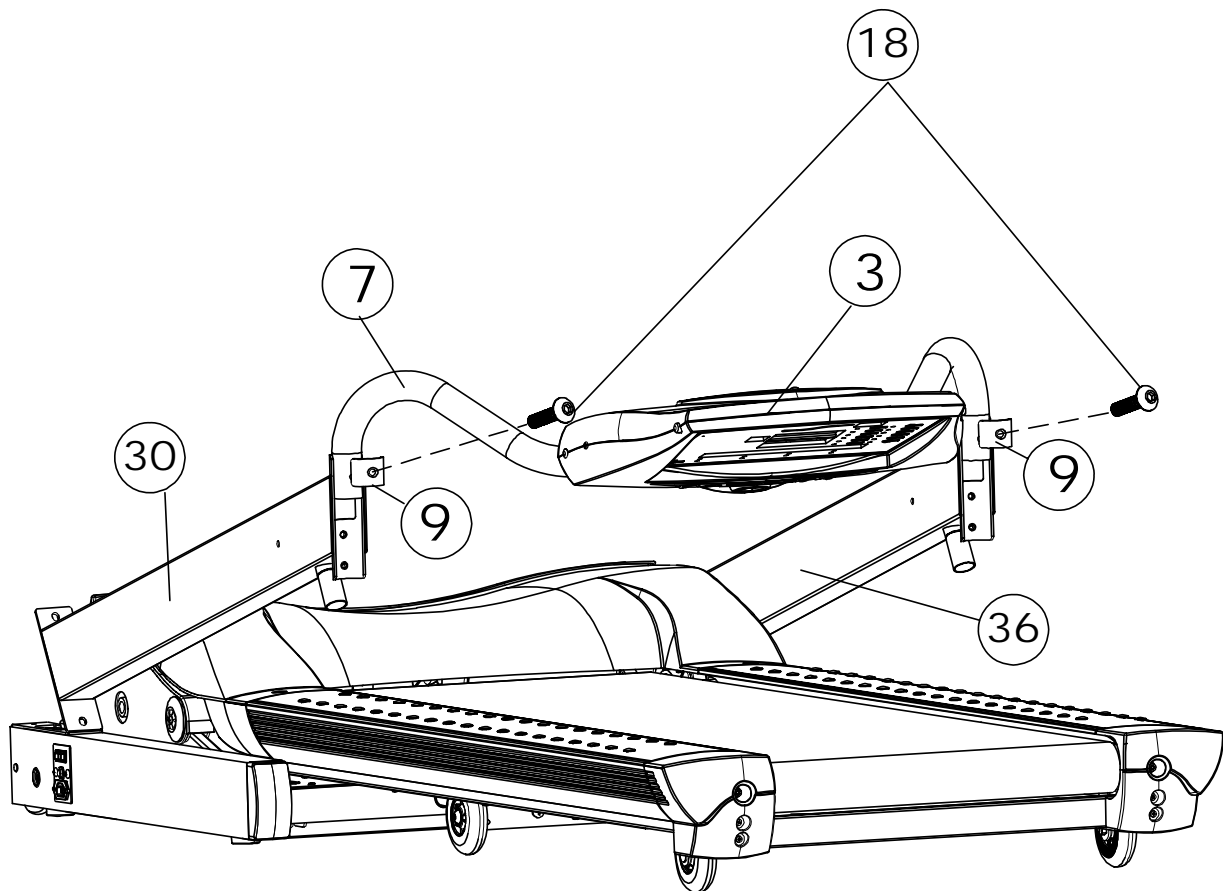
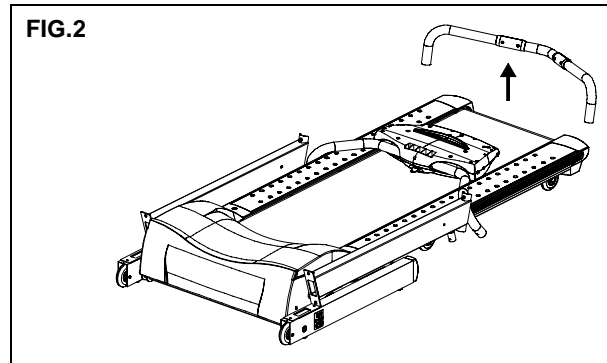
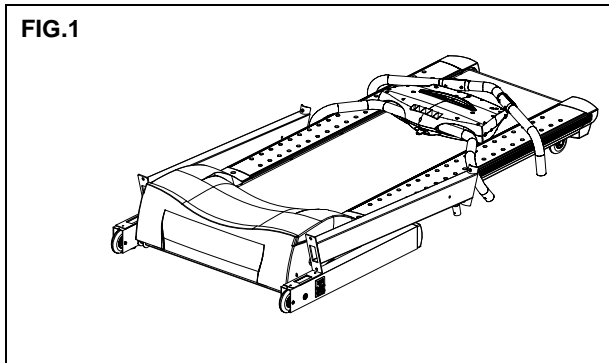

ASSEMBLY**STEP 2:**

**NOTE: YOU WILL NEED THE HELP OF ANOTHER PERSON IN ORDER TO COMPLETE STEP 2 OF THE ASSEMBLY PROCEDURE.**

First make sure to connect the wires. Then, simply have one person hold the Uprights (30 and 36) in place on the Base Frame (55) while the other secures it with four M8 x 15mm Allen Head Screw (19).

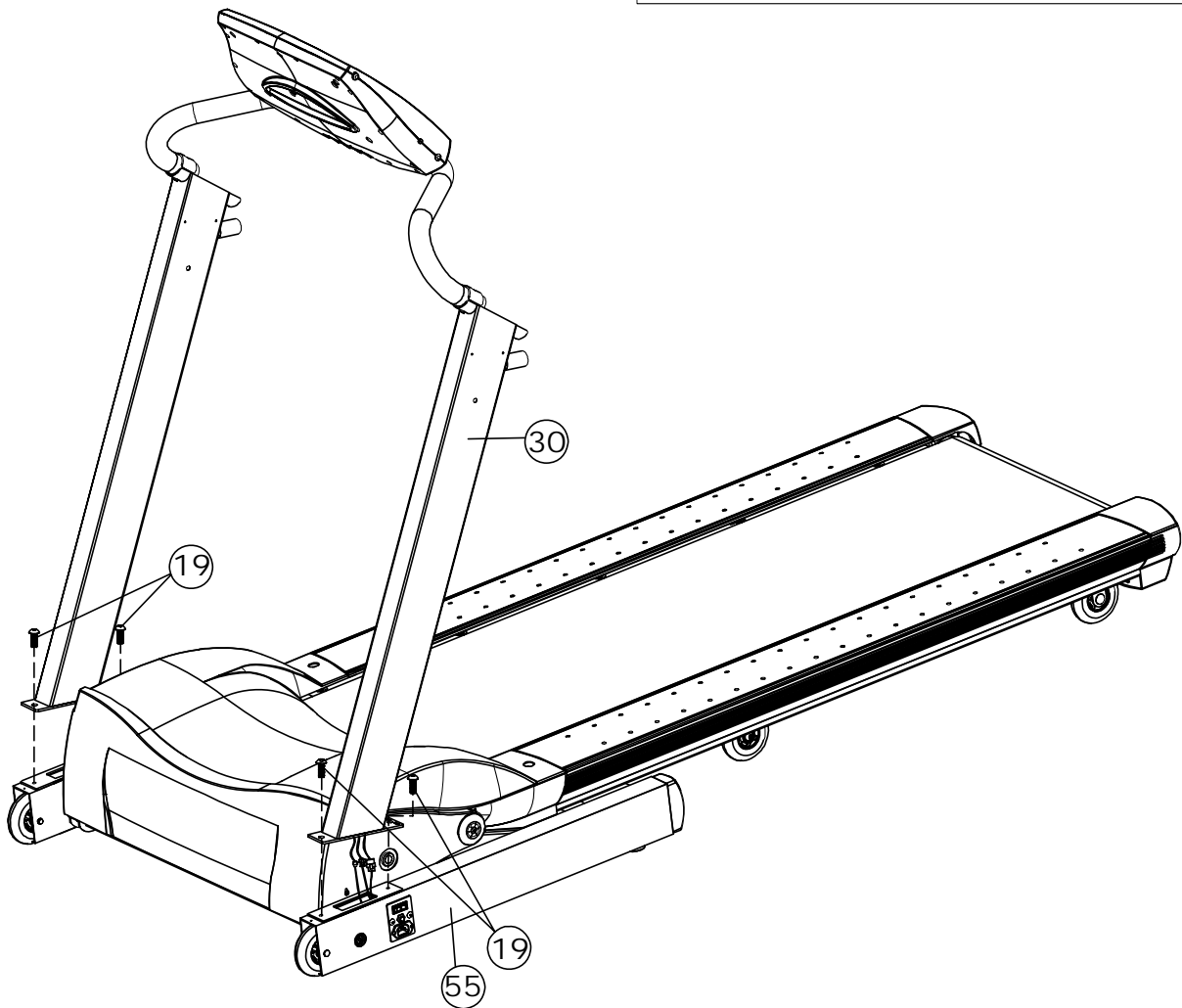
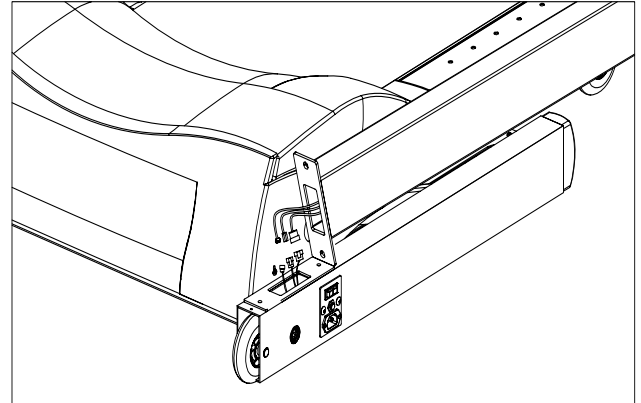

ASSEMBLY**STEP 3:**

Rotate the Console Housing (3) to position as shown and secure with two M6 x 15 Console Fixing Screws (11).

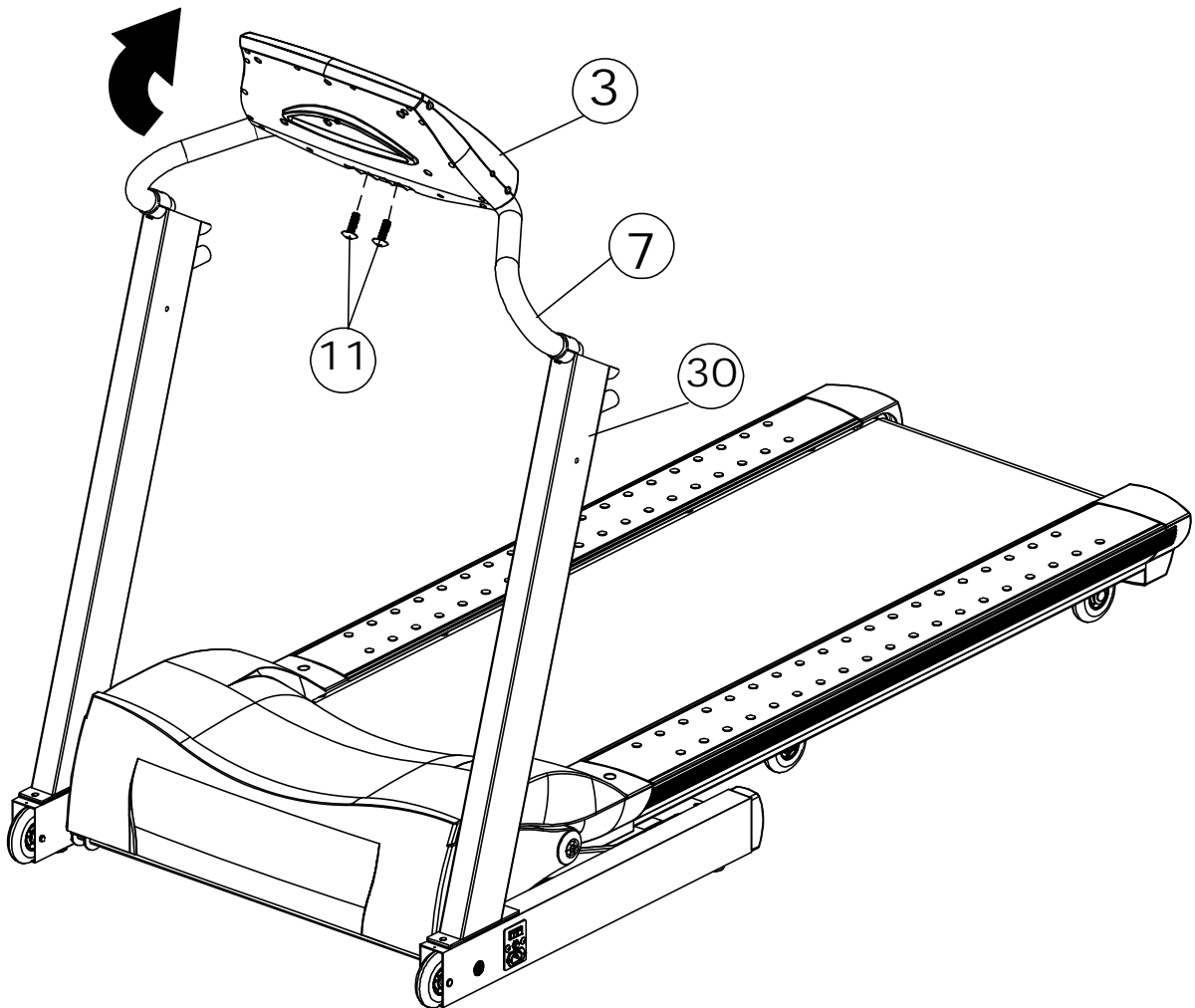

ASSEMBLY**STEP 4:**

Attach the Upright Cross Brace (32) to the Left and Right Uprights (30 and 36) and secure with Metal Caps (29) and Upright Cross Brace Bolts (28). Do Not fully tighten Bolts (28) at this point but do fully tighten Screws (19) after you've assembled the cross brace (32).

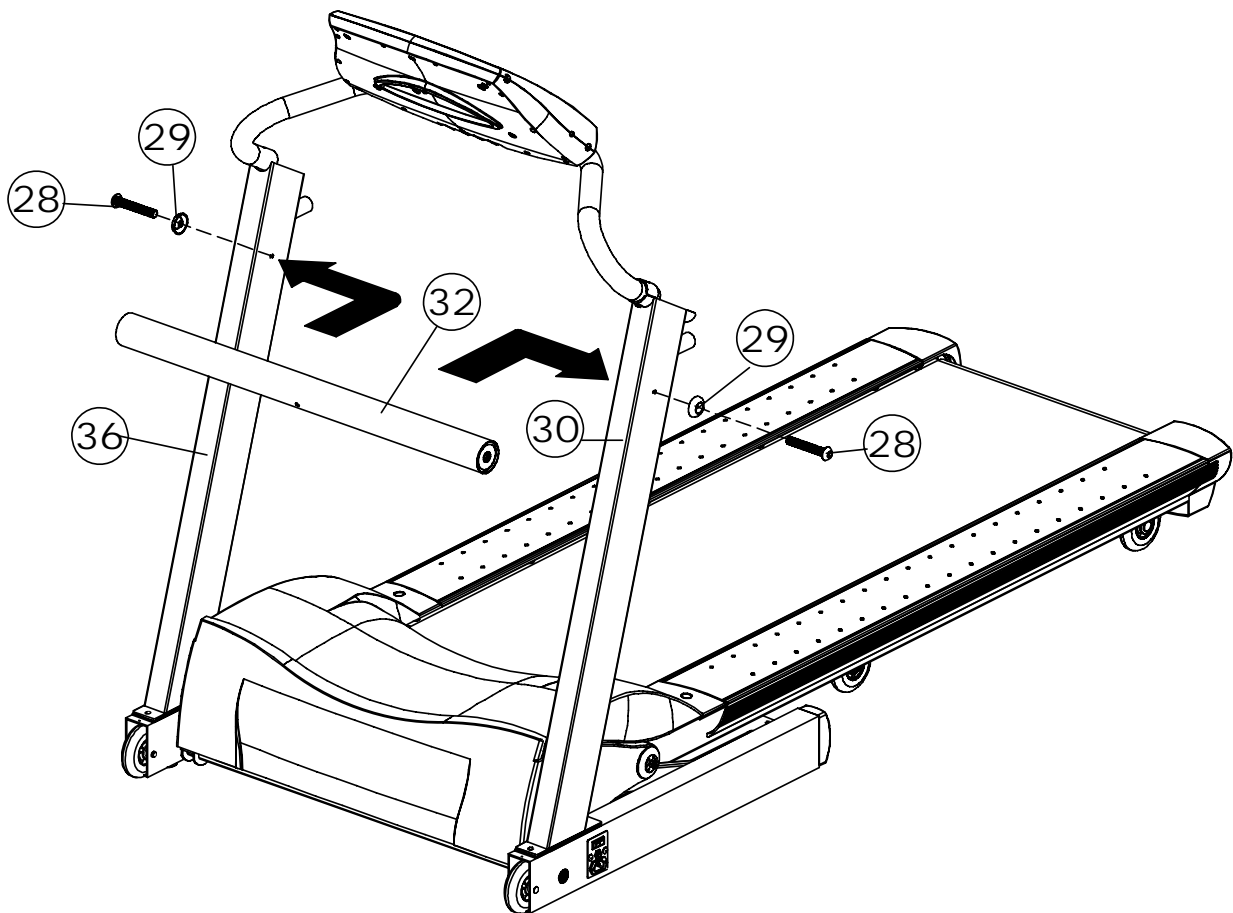

ASSEMBLY**STEP 5:**

Remove the Bracket Screw (135) from Console Tray Fixing Plate (21). Attach the Console Tray (22) to the Console Housing (3) and secure by screwing the Bracket Screw (135) through the Console Tray Fixing Plate (21) and into the Console Housing (3), as shown in FIG3.

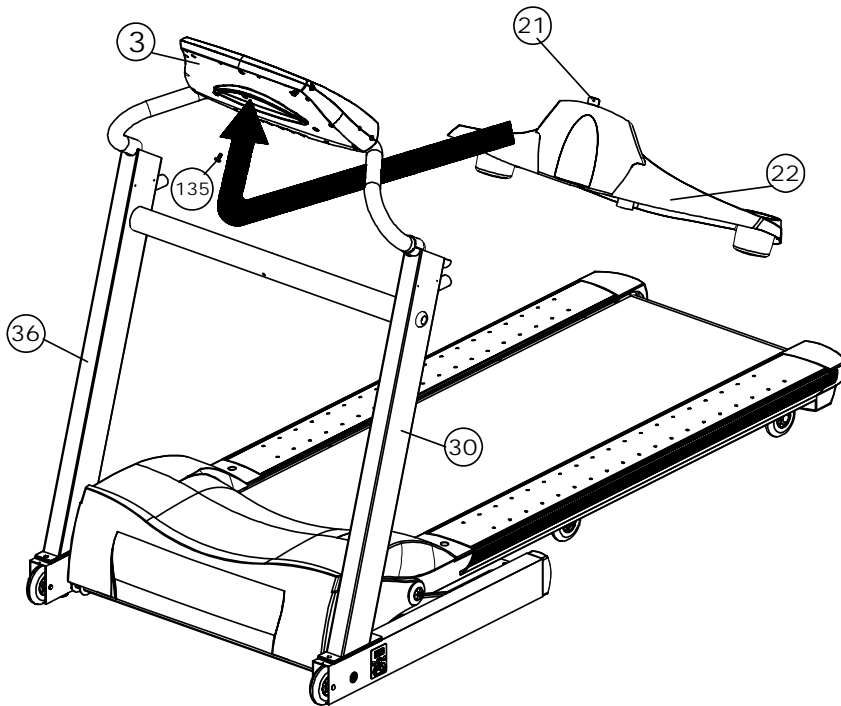
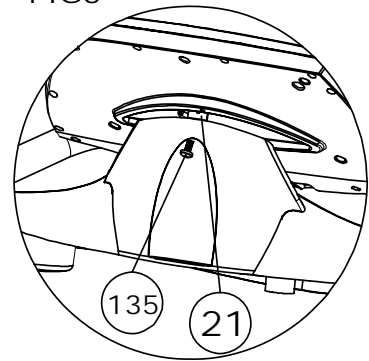

FIG3





ASSEMBLY**STEP 6:**

Insert the Console Tray Support Tube (31) into the Upright Cross Brace (32). Rotate the Upright Cross Brace (32) and insert the top of the Console Tray Support Tube into the Console Tray (22), as shown in FIG4. Secure the Console Tray Support Tube (31) in place using the M8 x 25 Console Tray Support Tube Bolt (33).

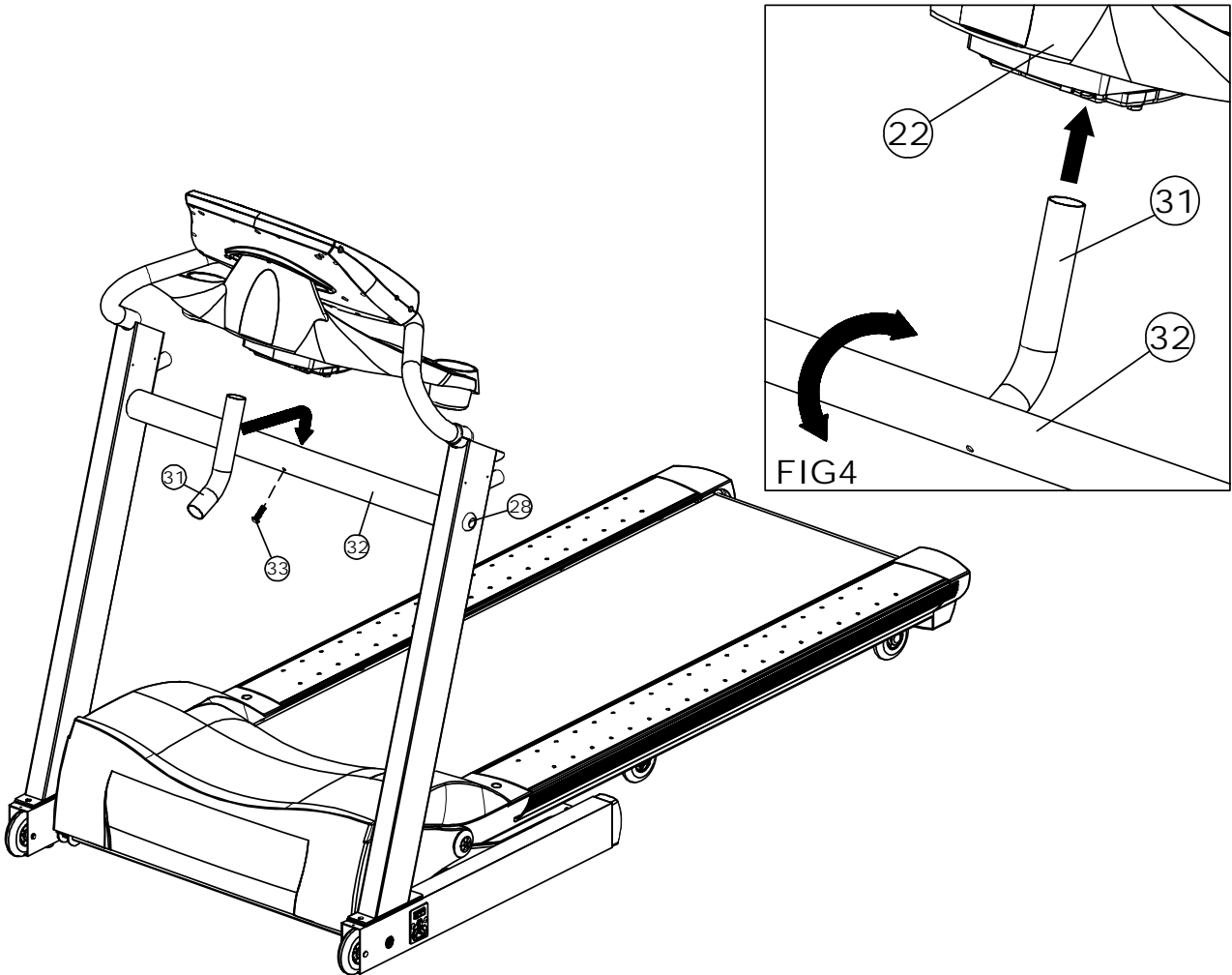

ASSEMBLY**STEP 7:**

Attach the Handlebar-Right (34) and Handlebar-Left (24) to the Right and Left Uprights (36 and 30) and secure with Handlebar Fixing Plates (17) and M8 x 50 Allen Head Bolts (18).

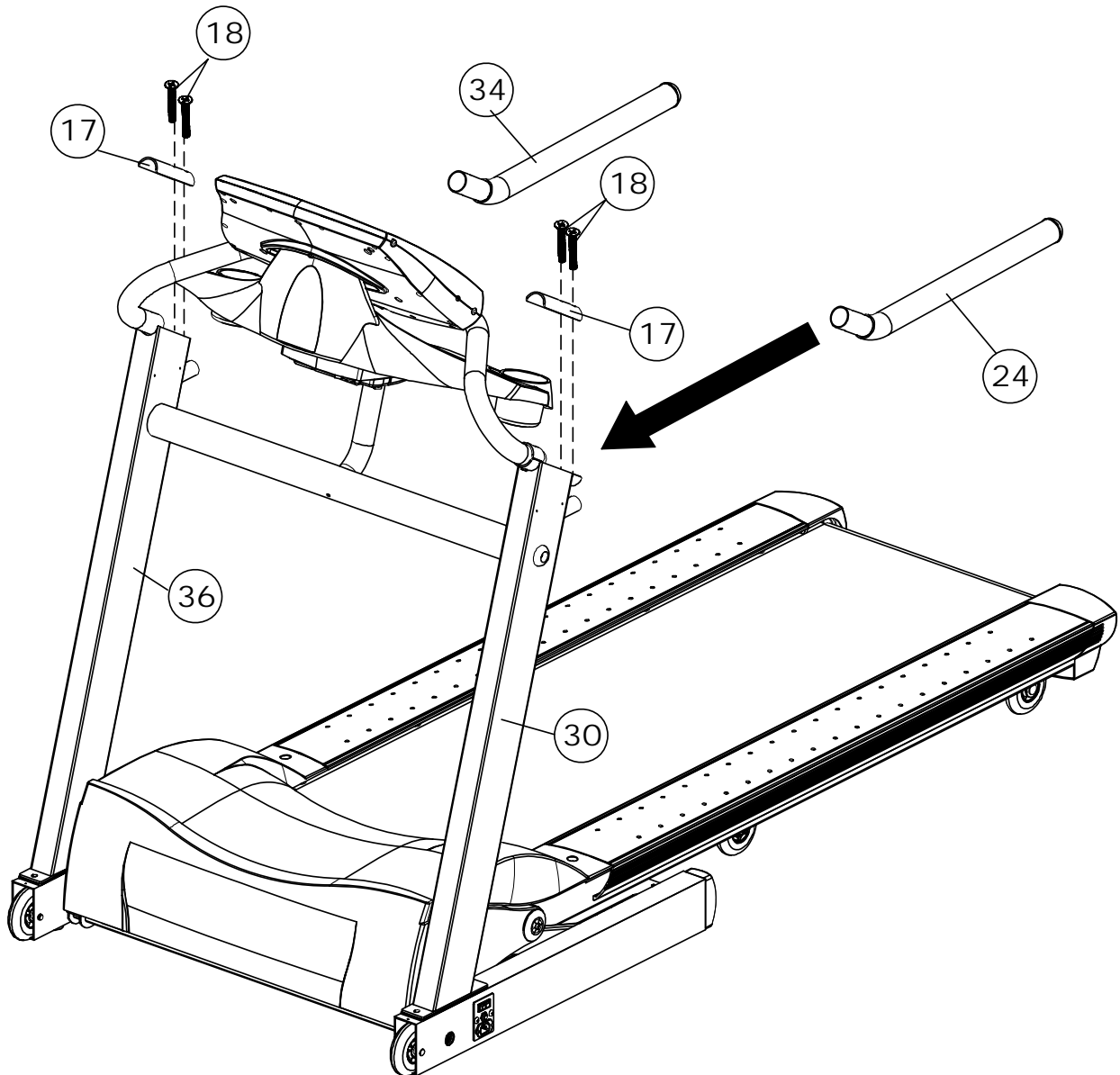

ASSEMBLY**STEP 8:**

Connect the EKG Pulse Wire as FIG.5 shown. Then attach the Front Handlebar (35) to Upright – Right (36) and Upright – Left (30) with two M6 x 15 Screw (11). Then you can fully tighten the Upright Cross Brace Bolts (28) now.

**NOTE:** Please make sure not to pinch the Sensor Wires when attaching the Handlebars.

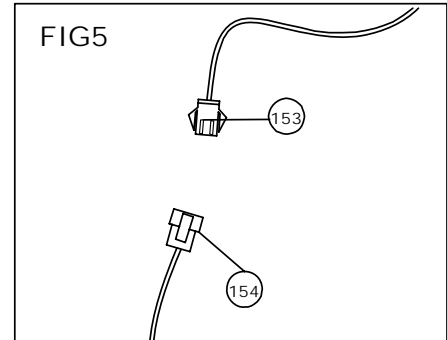
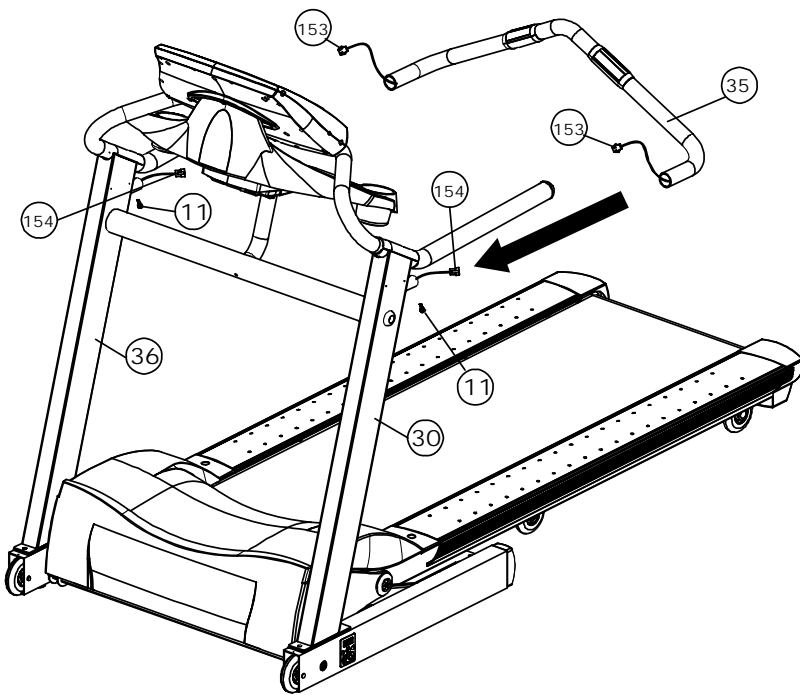

ASSEMBLY**STEP 9:**

Attach the Handlebar Cover-Right #1 (15) and Handlebar Cover-Right #2 (14) to the Upright-Right (36) and secure with #8 x 25 Handlebar Cover Screws (16) and Plastic Fixing Inserts (137). Repeat the procedure on the Upright-Left (30) with Handlebar Cover-Left #1 (12), Handlebar Cover-Left#2 (13) and #8 x 25 Handlebar Cover Screws (16) and Plastic Fixing Inserts (137).

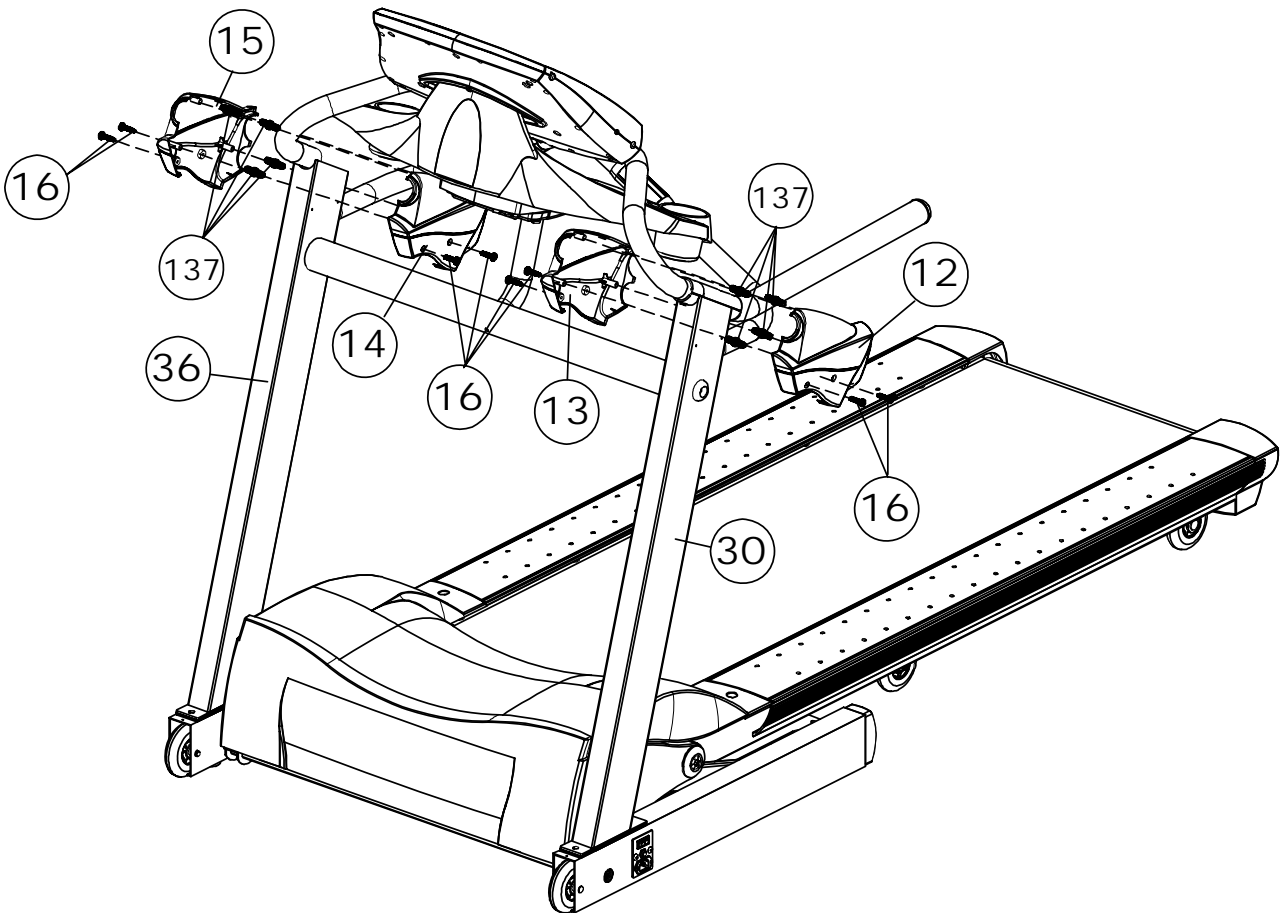

ASSEMBLY**STEP 10:**

Plug the Speaker Wires into the Console Housing (3). Attach the Right and Left Speakers (149 and 150) to the Console Housing (3) and secure with Knobs.

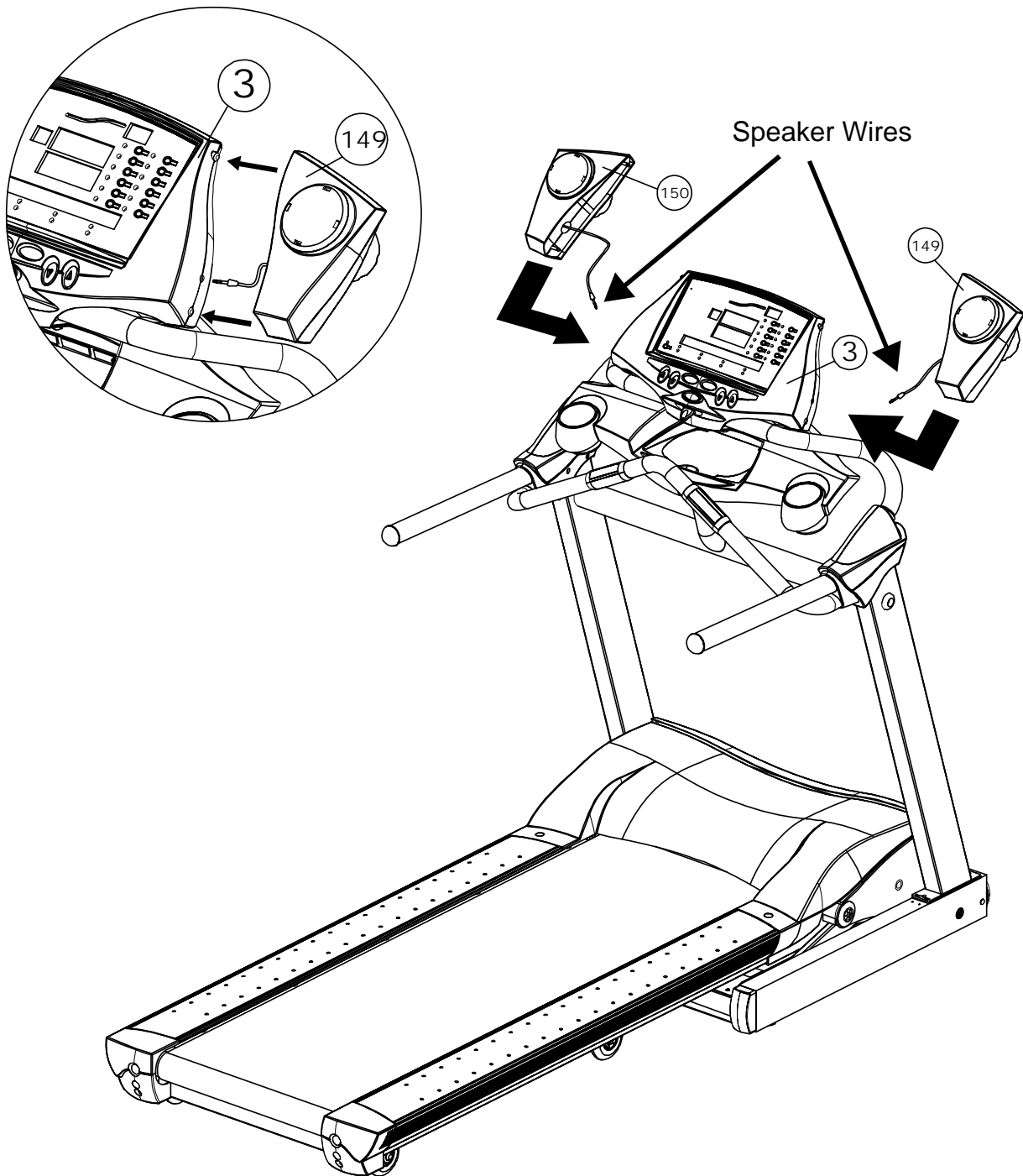

ASSEMBLY**STEP 11:**

Remove the two #8 x 25mm Screw (16) from the Base Frame (55) then attach the Transport Wheel Cover (155) to Base Frame (55) with two #8 x 25mm Screw (16).

CONGRATULATIONS, YOU'VE NOW ASSEMBLED YOUR SMOOTH 9.25X TREADMILL.

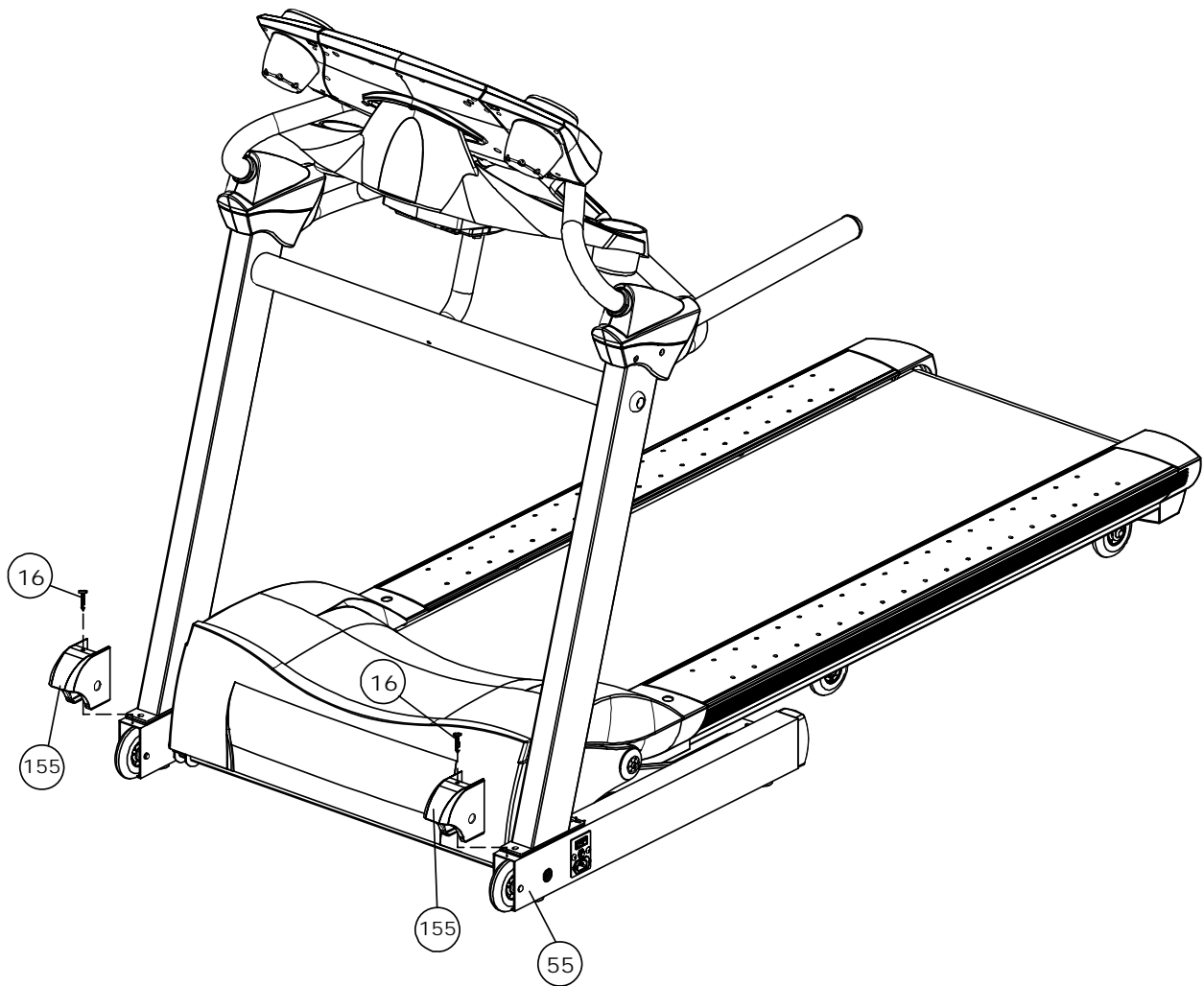

## LEVEL ADJUSTMENT

### **LEVEL ADJUSTMENT:**

To adjust the levelers follow these instructions:

You will need someone to help you with this procedure, as you will need to tip the treadmill on its side.

Tip the treadmill to the left/right. You will then see the STABILIZERS. These will need to be screwed either in or out to level the treadmill. Repeat for the other side. It may help to use a spirit level when adjusting the level on your treadmill.

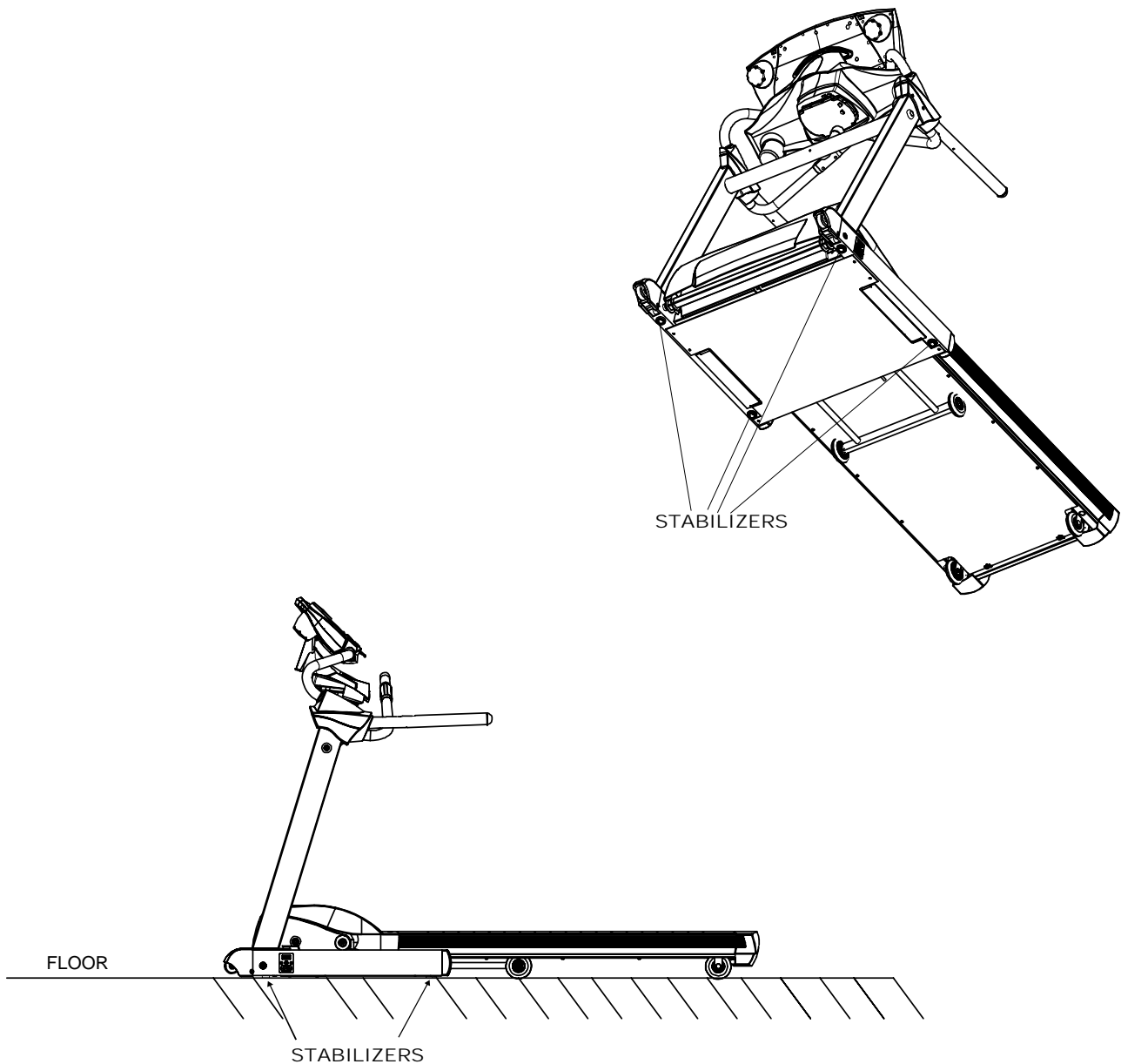

TRANSPORT INSTRUCTIONS**MOVING YOUR TREADMILL:**

There are **TRANSPORT WHEELS** located under the front of the base frame of your Smooth 9.25HR treadmill. The easiest way to move the treadmill is to lift the deck up from the rear until the **TRANSPORT WHEELS** touch the floor. Then simply wheel the treadmill to a desired location and set the deck back on the floor.

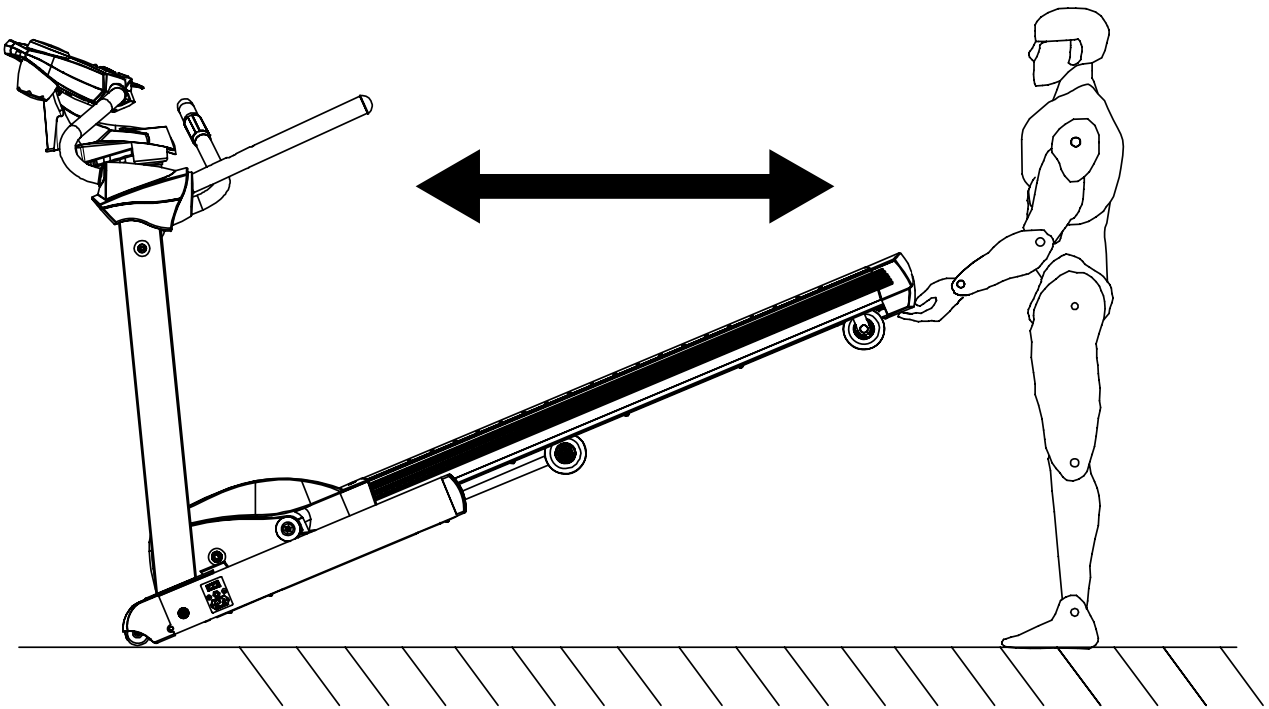



## MAINTENANCE

### HOW TO MAINTAIN THE SMOOTH 9.25HR TREADMILL:

Proper maintenance is very important to ensure your treadmill is always in top working condition. Improper maintenance could cause damage or shorten the life of your treadmill and exceed the LIMITED WARRANTY coverage.

- **Important:** Never use abrasives or solvents to clean the treadmill. To prevent damage to the computer, keep liquids away and keep it out of direct sunlight.
- Inspect and tighten all parts of the treadmill regularly. Replace any worn parts immediately.

### BELT ADJUSTMENT:

Belt adjustment and tension performs two functions: adjustment for tension and centering. The running belt has been adjusted properly at the factory. However transportation, uneven flooring or other unpredicted reasons could cause the belt to shift off center resulting in the belt rubbing with the plastic side rail or end caps and possibly causing damage. To adjust the belt back to it's proper position please follow the directions below:

- **Walking belt has shifted to the left:** First unplug the power cord from the surge protector. Using the hex key provided, turn the left rear roller adjustment bolt 1/4 turn in the clockwise direction. Plug the power cord back into the surge protector and run the treadmill at 2.5 mph. You should see the belt start to correct itself, moving back towards the center. Repeat the above procedure until the walking belt is centered. It may be necessary to set walking belt tension once you have completed this procedure if the belt feels like it is slipping while walking. Refer below to the "Walking belt slipping" instructions.
- **Walking belt has shifted to the right:** First unplug the power cord from the surge protector. Using the hex key provided, turn the right rear roller adjustment bolt 1/4 turn in the clockwise direction. Plug the power cord back into the surge protector and run the treadmill at 2.5 mph. You should see the belt start to correct itself, moving back towards the center. Repeat the above procedure until the walking belt is centered. It may be necessary to set walking belt tension once you have completed this procedure if the belt feels like it is slipping while walking. Refer below to the "Walking belt slipping" instructions.
- **Walking belt is slipping:** First unplug the power cord from the surge protector. Using the hex key provided, turn both the left and right rear roller adjustment bolts the same distance, usually a 1/4 turn in the clockwise direction. Plug the power cord back into the surge protector and run the treadmill at 2.5 mph. You should now walk on the belt to determine if the belt is still slipping. Repeat the above procedure until the walking belt is not slipping. The tension should be just tight enough not to slip.

**WARNING! Do not over tighten rollers! This will cause premature roller bearing failure!**

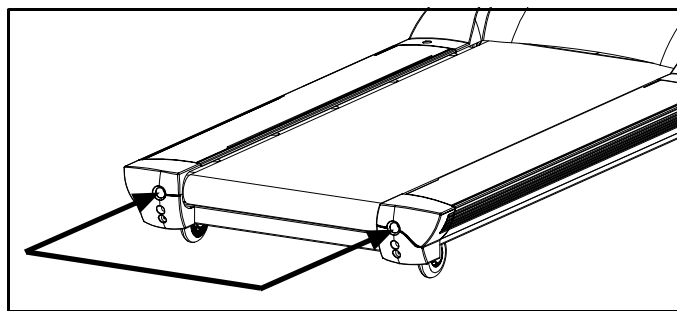

Right and left tension bolts are located at the rear of the treadmill.

## MAINTENANCE

### CLEANING:

Routine cleaning of your treadmill will extend the product's life.

- **Warning:** To prevent electrical shock, be sure the power to the treadmill is OFF and the power cord is unplugged from the wall electrical outlet before attempting any cleaning or maintenance.
- **Important:** Never use abrasives or solvents to clean the treadmill. To prevent damage to the computer, keep liquids away and keep it out of direct sunlight.
- **After each workout:** Wipe off the console and other treadmill surfaces with a clean, water dampened soft cloth to remove excess perspiration.
- **Weekly:** Use of a treadmill mat is recommended for ease of cleaning. Dirt from your shoes contacts the belt and eventually makes it to underneath the treadmill. Vacuum underneath treadmill once a week.

### DECK LUBRICATION:

The walking belt has been pre-lubricated at the factory. However, it is recommended that the walking board be checked periodically for lubrication to ensure optimal treadmill performance. Your treadmill should not have to be lubricated usually within the first year or 500 hours of use. Call your local Smooth dealer for service or questions regarding Smooth products.

Every 3 months of operation lift the sides of the walking belt and feel the top surface of the walking board as far as you can reach. If you feel signs of silicone, no further lubrication is required. If it feels dry to the touch, follow the instructions below.

Please use Lube 'N Walk (can be purchased from your dealer or call the number on the front of the manual), or a non-petroleum based silicone such as "Napa 8300" (available at most stores).

#### To apply lubricant to the walking belt:

1. Position the walking belt so that the seam is located on top and in center of the walking board.
2. Insert the spray nozzle into the spray head of the lubricant can.
3. While lifting the side of the walking belt, position the spray nozzle between the walking belt and the board approximately 6" from the front of the treadmill. Apply the silicone spray to the walking board, moving from the front of the treadmill to the rear. Repeat this on the other side of the belt. Spray approximately 4 seconds on each side.
4. Allow the silicone to "set" for 1 minute before using the treadmill.

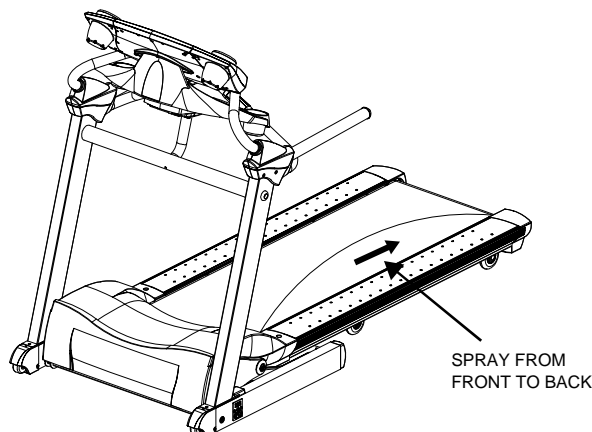

## SMOOTH 9.25X MOTORIZED TREADMILL

WARRANTY**LIMITED HOME USE WARRANTY – SMOOTH FITNESS Treadmills Warranty**

**Warranty Coverage:** EVO Fitness and Smooth Fitness, Inc. ("Smooth Fitness") warrants to the original owner that each new product to be free from defects in workmanship and material, under normal use and conditions.

**Period of Coverage:** The Warranty on this product runs from the date of original purchase using the following schedule:

Model Name	Frame	Drive Motor	Parts & Electronics	Labor
5.25	Lifetime	Lifetime	3 years	1 year
6.25HR	Lifetime	Lifetime	5 years	1 year
7.1HR PRO	Lifetime	Lifetime	5 years	1 year
9.17HRO	Lifetime	Lifetime	5 years	1 year
9.25HR	Lifetime	Lifetime	5 years	1 year
9.25X	Lifetime	Lifetime	Lifetime	1 year

Labor: Smooth Fitness will reimburse for labor costs for One (1) year. Smooth Fitness reserves the right to either: Hire and reimburse an independent service technician who will come into the home for the repair,  
OR

In the event that there is not an available certified Smooth Fitness service technician, Smooth will send the part directly to the consumer and will pay \$75 US per occurrence for the labor costs of such repair. If multiple repair attempts must be made for one reported problem, Smooth will only reimburse once per occurrence.

Smooth Fitness reserves the right to inspect damaged parts for misuse. Your Original Receipt is proof of purchase and should be kept with the product manual. You may be required to show proof of purchase prior to warranty service being initiated.

**Remedy Provided by Smooth Fitness:** Smooth Fitness will provide a replacement part free of charge if a defect is found during the Warranty period. Smooth Fitness may at its discretion, choose to provide any of following parts or repair options. In the event that a part is determined in need of replacement, upon receipt of the part by Smooth Fitness, Smooth Fitness may send out the part by UPS ground or another such carrier directly to the customer's home. The customer is responsible for the cost of sending the part to Smooth Fitness.

**For the 9.25X Model Only:** This warranty covers all parts including frame, electronics and wear parts for a lifetime. If Smooth Fitness in its sole discretion determines that the treadmill cannot or should not be repaired, it may decide to purchase the unit for the residual value in accordance with the following: 25% of retail purchase price after 5 years, 15% after 10 years, 5% after 15 years.

Any redemption may be by repair or replacement of the affected parts and/or product at the sole discretion of Smooth Fitness, by personnel approved by Smooth Fitness.

Parts repaired or replaced pursuant to this Warranty shall be warranted for the unexpired portion of the Warranty applying to the original product. Any technical advice furnished before or after delivery in regard to the use or application of Smooth Fitness products is furnished without charge and on the basis that it represents Smooth Fitness' best judgment under the circumstances but that the advice is used at your sole risk.

**Procedure for Obtaining Your Remedy Under This Warranty:** To obtain service on a Smooth Fitness product, call Smooth Fitness. In the instance that service is not available in an area, Smooth Fitness, at its discretion, can either 1) find a service technician in your area to perform warranty service, 2) have a local dealer perform warranty service, or 3) send the warranty parts to you and reimburse as described above. To help the technician assist you, please have the following information ready:

- Model name or number from the cover of the manual;
- Serial number located on the frame of the unit; and
- The part description and the order number.

**Limitations on Warranty:** This Warranty will only apply to the original end user. This Warranty does not cover wear and tear (except the 9.25X treadmill), any problems, damages or failures that are caused by accident, improper assembly, failure to observe cautionary labels on the product, failure to operate the product correctly, power grid failures or spikes from your local electricity provider, abuse or freight damage. Smooth Fitness does not warrant against any damage or defects that may result from repair or alterations made to the product by an unauthorized repair facility.

This Warranty shall terminate if you sell or otherwise transfer this product. This Warranty does not apply to any product shipped or handled outside of the United States or Canada. This Warranty does not apply if the product is used as a rental product or in commercial use. Consequential and incidental damages are not recoverable under this Warranty. (Some states do not allow the exclusion or limitation of incidental or consequential damages, so the above limitation or exclusion may not apply to you.)

THIS WARRANTY IS EXPRESSLY IN LIEU OF ALL OTHER EXPRESS WARRANTIES. ALL IMPLIED WARRANTIES, INCLUDING WARRANTIES OF MERCHANTABILITY OR FITNESS FOR ANY PARTICULAR PURPOSE, ARE LIMITED IN DURATION TO ONE (1) YEAR FROM THE EFFECTIVE DATE OF THIS WARRANTY. SMOOTH FITNESS IS NOT LIABLE FOR CONSEQUENTIAL OR INCIDENTAL DAMAGES RESULTING FROM ANY DEFECT IN PARTS NOR FOR ANY BREACH OF EXPRESS OR IMPLIED WARRANTIES. SMOOTH FITNESS' SOLE LIABILITY UNDER THIS WARRANTY IS LIMITED TO THE TERMS DESCRIBED IN THIS FORM. THIS WARRANTY GIVES YOU SPECIFIC LEGAL RIGHTS, AND YOU MAY ALSO HAVE OTHER RIGHTS WHICH VARY FROM STATE TO STATE.

FORM WS-1 (rev. 08/2005)

## IMPORTANT STEPS

### **Warning:**

Before using this product, please consult your personal physician for a complete physical examination. Frequent and strenuous exercise should be approved by your doctor first. If any discomfort should result from your use of this product, stop exercising and consult your doctor. Proper usage of this product is essential. Please read your manual carefully before exercising.

Please keep all children away from the equipment during use and when equipment is unattended.

Always wear appropriate clothing, including athletic shoes, when exercising. Do not wear loose clothing that could become caught during exercising.

Make sure that all bolts and nuts are tightened when equipment is in use. Periodic maintenance is required on all exercise equipment to keep it in good condition.

### **Before beginning:**

How you begin your exercise program depends on your physical condition. If you have been inactive for several years, or are severely overweight, you must start slowly and increase your time gradually, a few minutes per week.

Initially you may be able to exercise only for a few minutes in your target zone. However, your aerobic fitness will improve over the next six to eight weeks. Don't be discouraged if it takes longer. It's important to work at your own pace. Ultimately, you'll be able to exercise continuously for 30 minutes. And the better your aerobic fitness, the harder you will have to work to stay in your target zone. But remember these essentials:

- Contact your physician before starting a workout or training program. Have your doctor review your training and diet programs to advise you of a workout routine you should adopt.
- Begin your training program slowly with realistic goals that have been set by you and your doctor.
- Supplement your program with some type of aerobic exercise such as walking, jogging, swimming, dancing and/or bicycling. Monitor your pulse frequently. If you do not have an electronic heart rate monitor, have your physician show you the proper way to manually check your pulse by using your wrist or neck. Establish your target heart rate based on your age and condition.
- Drink plenty of fluids during the course of your routine. You must replace the water content lost from excessive exercising to avoid dehydration. Avoid drinking large amounts of cold liquids. Fluids should be at room temperature when consumed.



The Surgeon General  
has determined that lack  
of physical activity is  
detrimental to your health.™

## TARGET HEART RATE

### Finding your pulse:

To make sure your heart is beating in its target zone, you'll need to know how to monitor your heart rate. The easiest way is to feel the pulse in the carotid artery on either side of your neck, between the windpipe and the large neck muscles. Count the number of beats in ten seconds, and then multiply that number by six. This gives you the number of beats per minute.

How fast should your heart beat during aerobic exercise? Fast enough to reach and stay in its "target zone," a range of beats per minute that is largely determined by your age and physical condition. To determine your target zone, consult the chart we have provided.

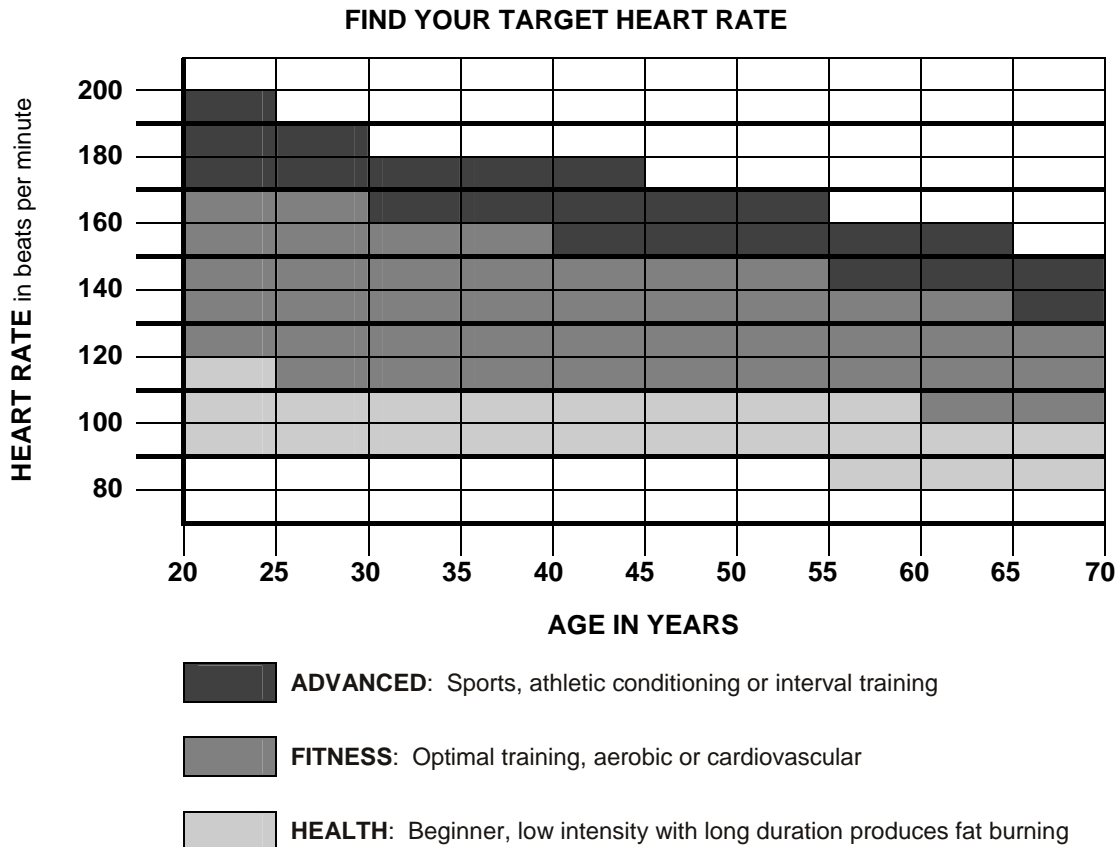

### Aerobic exercise:

Is any sustained activity that sends oxygen to your muscles via your heart and lungs. It will improve the fitness of your lungs and heart: your body's most important muscle. Aerobic fitness is promoted by any activity that uses your large muscle groups - arms, legs or buttocks, for example. Your heart beats quickly and you breathe deeply. An aerobic exercise should be part of your entire exercise routine.

MUSCLE CHART**Targeted muscle groups:**

The exercise routine that is performed on this product will develop primarily lower body muscle groups. These muscle groups are shown in gray color on the chart below.

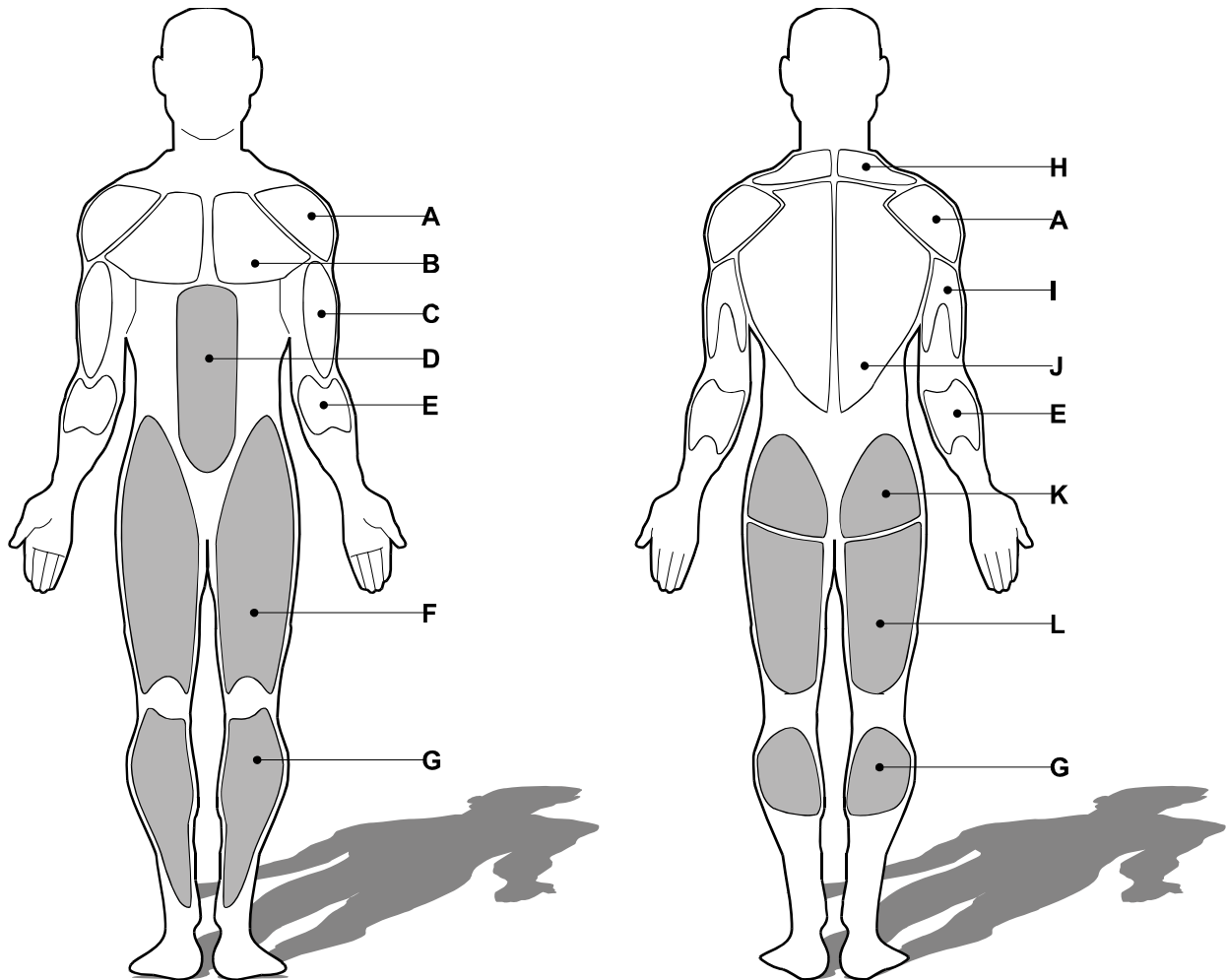

Shoulder muscles	<input type="checkbox"/> A	<input type="checkbox"/> B	Pectoral muscles
Bicep muscle	<input type="checkbox"/> C	<input type="checkbox"/> D	Abdominal muscles
Forearm muscles	<input type="checkbox"/> E	<input type="checkbox"/> F	Quadricep muscles
Calf muscles	<input type="checkbox"/> G	<input type="checkbox"/> H	Trapezius muscles
Tricep muscles	<input type="checkbox"/> I	<input type="checkbox"/> J	Back muscles
Gluteal muscles	<input type="checkbox"/> K	<input type="checkbox"/> L	Hamstring muscles

## STRETCHING ROUTINE

### **Warm up and cool down:**

A successful exercise program consists of a warm-up, aerobic exercise, and a cool-down. Do the entire program at least two and preferably three times a week, resting for a day between workouts. After several months, you can increase your workouts to four or five times per week.

Warming up is an important part of your workout, and should begin every session. It prepares your body for more strenuous exercise by heating up and stretching out your muscles, increasing your circulation and pulse rate, and delivering more oxygen to your muscles. At the end of your workout, repeat these exercises to reduce sore muscle problems. We suggest the warm-up and cool-down exercises on the following pages:

### **Toe Touch:**

Slowly bend forward from your waist, letting your back and shoulders relax as you stretch toward your toes. Reach down as far as you can and hold for 15 counts.

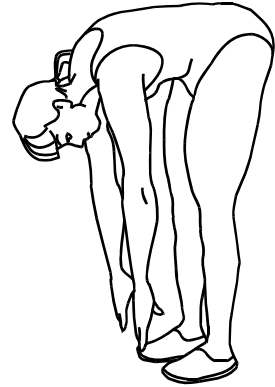

### **Shoulder Lift:**

Lift your right shoulder up toward your ear for one count. Then lift your left shoulder up for one count as you lower your right shoulder.



### **Head Roll:**

Rotate your head to the right for one count, feeling the stretch up the left side of your neck. Next, rotate your head back for one count, stretching your chin to the ceiling and letting your mouth open. Rotate your head to the left for one count, and finally, drop your head to your chest for one count.



STRETCHING ROUTINE**Hamstring Stretch:**

Sit with your right leg extended. Rest the sole of your left foot against your right inner thigh. Stretch toward your toe as far as possible. Hold for 15 counts. Relax and then repeat with left leg extended.

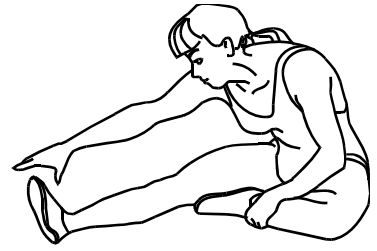
**Inner Thigh Stretch:**

Sit with the soles of your feet together with your knees pointing outward. Pull your feet as close into your groin as possible. Gently push your knees towards the floor. Hold for 15 counts.

**Side Stretch:**

Open your arms to the side and continue lifting them until they are over your head. Reach your right arm as far upward toward the ceiling as you can for one count. Feel the stretch up your right side. Repeat this action with your left arm.

**Calf-Achilles Stretch:**

Lean against a wall with your left leg in front of the right and your arms forward. Keep your right leg straight and the left foot on the floor; then bend the left leg and lean forward by moving your hips toward the wall. Hold, and then repeat on the other side for 15 counts.

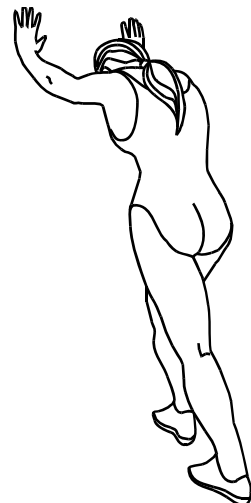



## TROUBLESHOOTING

### Troubleshooting

**NOTE:** Do not touch any internal electric wires without consulting the manufacturer.

#### **No display on the Computer LED, after the power is switched on:**

1. Make sure the power cord has been plugged in properly to the power switch on the base frame and mains power socket.
2. Make sure the safety key is inserted properly into the safety key slot on the console. Try pulling it in and out several times until the LED lights up.

#### **Computer LED lights up but the running belt has no movement:**

1. Follow the console operating instructions for the QUICK START manual program then press the Start button to see if the belt will move. The belt should move at 0.5 miles per hour.
2. If the belt still does not move, press the Speed Up button and see if the speed LED window indicates the speed increasing.
3. If when you press the speed button the speed LED window indicates the speed increasing, but the belt still does not move please call Customer service at 1.888.800.1167.

#### **Treadmill will not start:**

1. Make sure the power cord is plugged into a surge protector, the surge protector is plugged into a properly grounded outlet and the surge protector is turned on (refer to the Power Requirements section in this manual).
2. Check the circuit breaker reset switch located on the front of the treadmill. Turn the power off, wait 5 minutes then press the rest switch.
3. Check the house electrical breaker box and the circuit breaker for the room the treadmill is located in. If it has tripped, reset or have an electrician replace the breaker in home.
4. Have an electrician check for inadequate voltage at the outlet.

#### **Treadmill loses power during use:**

1. Check the circuit breaker reset switch located on the front of the treadmill. Turn the power off, wait 5 minutes then press the rest switch. If the treadmill still will not operate, please call Customer service at 1.888.800.1167.
2. Check the house electrical breaker box and the circuit breaker for the room the treadmill is located in. If it has tripped, reset or have an electrician replace the breaker in home.

#### **Treadmill walking belt slows during use:**

Check to make sure the treadmill is securely plugged into an UL-listed surge protector, rated at 15 amps, with a 14-gauge cord of five feet or less and the surge protector is securely plugged into the outlet. If the treadmill still will not operate, please call Technical service at 1.888.800.1167.

#### **Treadmill walking belt slips or is not centered on rear roller:**

Refer to the Belt Adjustment section of this manual. If you require additional assistance please call Technical service at 1.888.800.1167.



Smooth Fitness  
112 Gaither Drive  
Mt. Laurel, NJ 08054

Toll Free Customer Service:  
**1.888.800.1167**

Website:  
[www.smoothfitness.com](http://www.smoothfitness.com)