



# Reebok<sup>®</sup> VISTA 8500

## USER'S MANUAL

Model No. RBTL09906.0

Serial No. \_\_\_\_\_

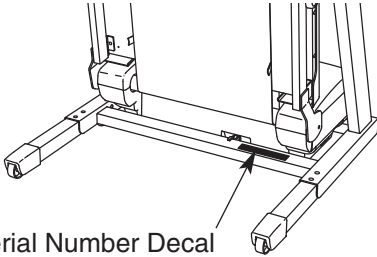

Serial Number Decal

### QUESTIONS?

As a manufacturer, we are committed to providing complete customer satisfaction. If you have questions, or if parts are damaged or missing, **PLEASE CONTACT OUR CUSTOMER SERVICE DEPARTMENT DIRECTLY.**

CALL TOLL-FREE:

**1-877-994-4999**

Mon.–Fri., 6 a.m.–6 p.m. MST

ON THE WEB:

[www.reebokservice.com](http://www.reebokservice.com)

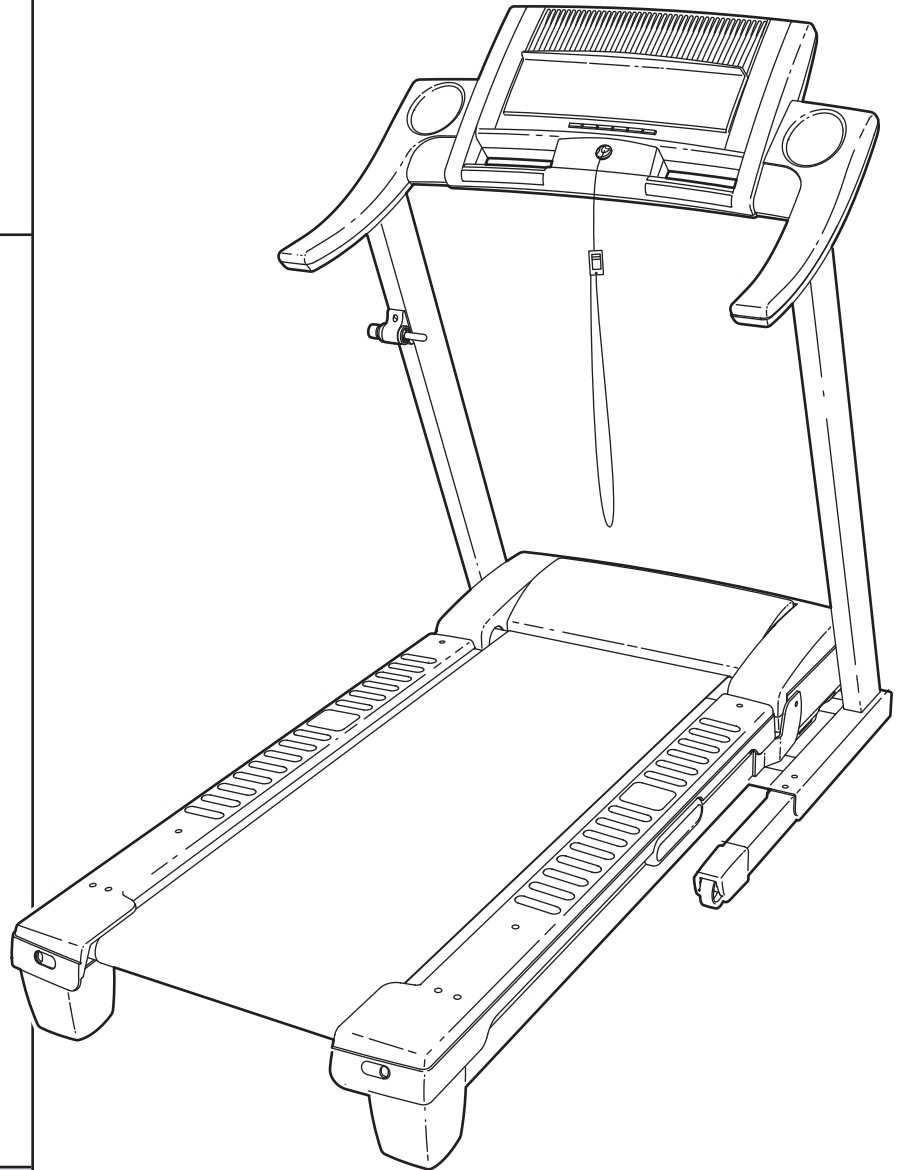

### CAUTION

Read all precautions and instructions in this manual before using this equipment. Save this manual for future reference.



Visit our website at

[www.reebokhomefitness.com](http://www.reebokhomefitness.com)

*new products, prizes,  
fitness tips, and much more!*



---

## TABLE OF CONTENTS

IMPORTANT PRECAUTIONS .....	3
BEFORE YOU BEGIN .....	5
ASSEMBLY .....	6
OPERATION AND ADJUSTMENT .....	11
HOW TO FOLD AND MOVE THE TREADMILL .....	23
TROUBLESHOOTING .....	25
CONDITIONING GUIDELINES .....	28
PART LIST .....	30
EXPLODED DRAWING .....	32
ORDERING REPLACEMENT PARTS .....	Back Cover
LIMITED WARRANTY .....	Back Cover

# IMPORTANT PRECAUTIONS

**⚠ WARNING:** To reduce the risk of burns, fire, electric shock, or injury to persons, read the following important precautions and information before operating the treadmill.

1. It is the responsibility of the owner to ensure that all users of this treadmill are adequately informed of all warnings and precautions.
2. Use the treadmill only as described in this manual.
3. Place the treadmill on a level surface, with at least eight feet of clearance behind it and two feet on each side. Do not place the treadmill on any surface that blocks air openings. To protect the floor or carpet from damage, place a mat under the treadmill.
4. Keep the treadmill indoors, away from moisture and dust. Do not put the treadmill in a garage or covered patio, or near water.
5. Do not operate the treadmill where aerosol products are used or where oxygen is being administered.
6. Keep children under the age of 12 and pets away from the treadmill at all times.
7. The treadmill should be used only by persons weighing 350 pounds or less.
8. Never allow more than one person on the treadmill at a time.
9. Wear appropriate exercise clothes when using the treadmill. Do not wear loose clothes that could become caught in the treadmill. Athletic support clothes are recommended for both men and women. *Always wear athletic shoes. Never use the treadmill with bare feet, wearing only stockings, or in sandals.*
10. When connecting the power cord (see page 11), plug the power cord into a surge suppressor (not included) and plug the surge suppressor into a grounded circuit capable of carrying 15 or more amps. No other appliance should be on the same circuit. Do not use an extension cord.
11. Use only a single-outlet surge suppressor that meets all of the specifications described on page 11. To purchase a surge suppressor, see your local REEBOK dealer or call the toll-free telephone number on the front cover of this manual and order part number 146148, or see your local electronics store.
12. Failure to use a properly functioning surge suppressor could result in damage to the control system of the treadmill. If the control system is damaged, the walking belt may change speed, accelerate, or stop unexpectedly, which may result in a fall and serious injury.
13. Keep the power cord and the surge suppressor away from heated surfaces.
14. Never move the walking belt while the power is turned off. Do not operate the treadmill if the power cord or plug is damaged, or if the treadmill is not working properly. (See TROUBLESHOOTING on page 25 if the treadmill is not working properly.)
15. Read, understand, and test the emergency stop procedure before using the treadmill (see HOW TO TURN ON THE POWER on page 13).
16. Never start the treadmill while you are standing on the walking belt. Always hold the handrails while using the treadmill.
17. The treadmill is capable of high speeds. Adjust the speed in small increments to avoid sudden jumps in speed.
18. The pulse sensor is not a medical device. Various factors, including the user's movement, may affect the accuracy of heart rate readings. The pulse sensor is intended only as an exercise aid in determining heart rate trends in general.
19. Never leave the treadmill unattended while it is running. Always remove the key, unplug the power cord, and switch the reset/off circuit breaker to the off position when the treadmill is not in use. (See the drawing on page 5 for the location of the circuit breaker.)
20. Do not attempt to raise, lower, or move the treadmill until it is properly assembled. (See ASSEMBLY on page 6, and HOW TO FOLD AND MOVE THE TREADMILL on page 23.) You must be able to safely lift 45 pounds (20 kg) to raise, lower, or move the treadmill.

21. When folding or moving the treadmill, make sure that the storage latch is fully closed.
22. Inspect and properly tighten all parts of the treadmill regularly.
23. Never insert any object into any opening.
24. **DANGER:** Always unplug the power cord immediately after use, before cleaning the

treadmill, and before performing the maintenance and adjustment procedures described in this manual. Never remove the motor hood unless instructed to do so by an authorized service representative. Servicing other than the procedures in this manual should be performed by an authorized service representative only.

25. This treadmill is intended for in-home use only. Do not use this treadmill in a commercial, rental, or institutional setting.

**⚠ WARNING:** Before beginning this or any exercise program, consult your physician. This is especially important for persons over the age of 35 or persons with pre-existing health problems. Read all instructions before using. ICON assumes no responsibility for personal injury or property damage sustained by or through the use of this product.

## SAVE THESE INSTRUCTIONS

The decals shown here have been placed on the treadmill. If a decal is missing, or if it is not legible, call the toll-free telephone number on the front cover of this manual and order a free replacement decal. Apply the decal in the location shown.

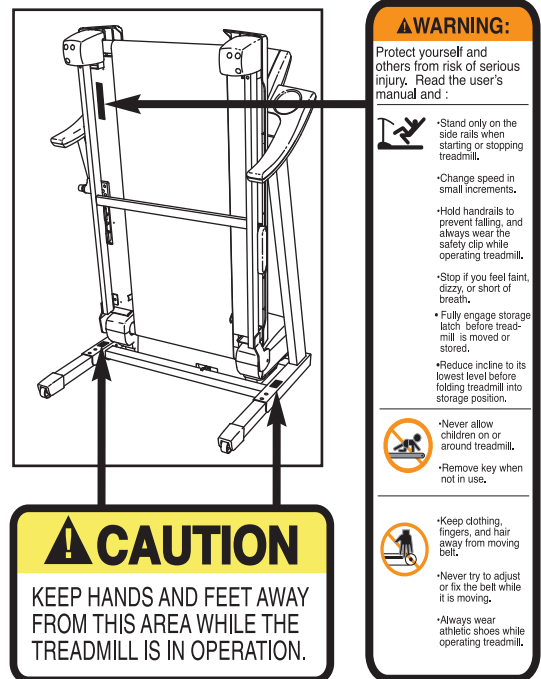

# BEFORE YOU BEGIN

Thank you for selecting the revolutionary REEBOK® VISTA 8500 treadmill. The VISTA 8500 treadmill offers an impressive array of features designed to make your workouts at home more enjoyable and effective. And when you're not exercising, the unique VISTA 8500 treadmill can be folded up, requiring less than half the floor space of other treadmills.

**For your benefit, read this manual carefully before you use the treadmill.** If you have questions after reading this manual, please see the front cover of this manual. To help us assist you, note the product model

number and serial number before contacting us. The model number of the treadmill is RBTL09906.0. The serial number can be found on a decal attached to the treadmill (see the front cover of this manual for the location).

**To avoid a registration fee for any service needed under warranty, you must register the treadmill at [www.reebokservice.com/registration](http://www.reebokservice.com/registration).**

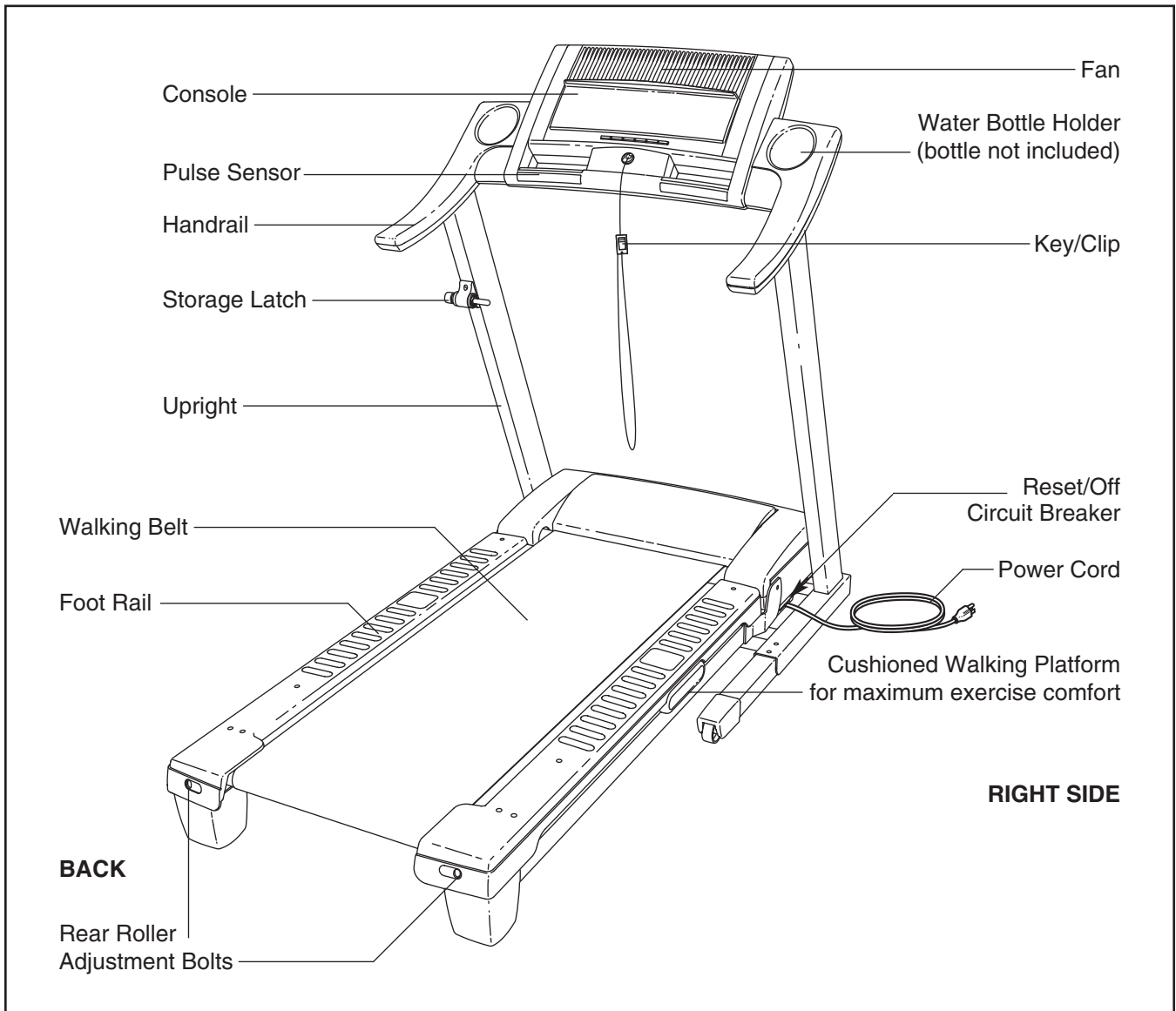

Before reading further, please review the drawing below and familiarize yourself with the labeled parts.



# ASSEMBLY

**Assembly requires two persons.** Set the treadmill in a cleared area and remove all packing materials. **Do not dispose of the packing materials until assembly is completed.**

Note: The underside of the treadmill walking belt is coated with high-performance lubricant. During shipping, a small amount of lubricant may be transferred to the top of the walking belt or the shipping carton. This is a normal condition and does not affect treadmill performance. If there is lubricant on top of the walking belt, simply wipe off the lubricant with a soft cloth and a mild, non-abrasive cleaner.

**Assembly requires the included hex key  and your own phillips screwdriver .**

**For help identifying the assembly hardware, see the drawings below.** The number in parentheses below each drawing is the key number of the part, from the PART LIST on page 30. The number following the parentheses is the quantity needed for assembly. **Note: Some small parts may have been pre-assembled. If a part is not in the parts bag, check to see if it has been pre-assembled. To avoid damaging plastic parts, do not use power tools for assembly.**

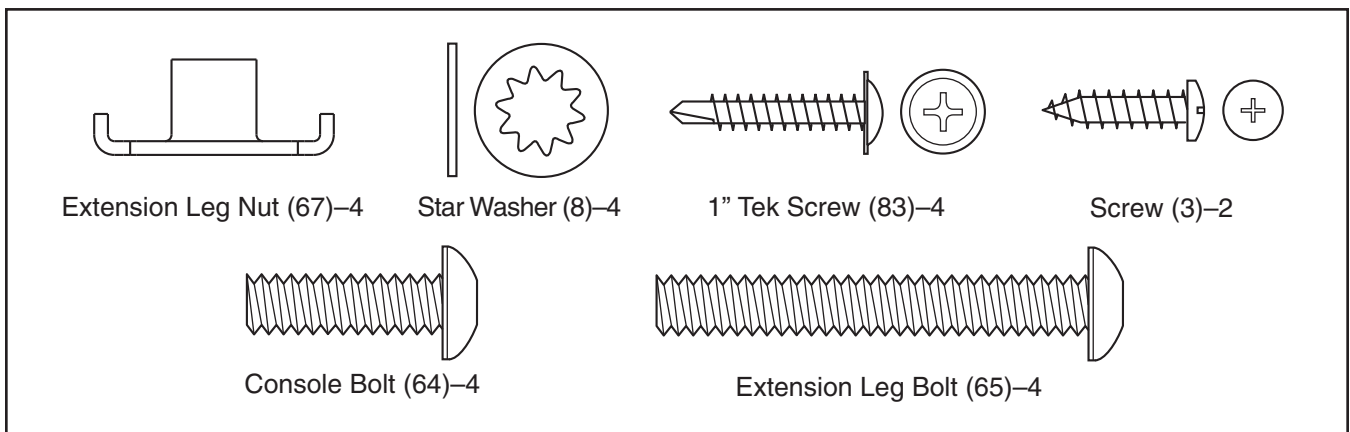

## 1. Make sure that the power cord is unplugged.

With the help of a second person, carefully tip the treadmill onto its left side as shown. Partially fold the Frame (58) so the treadmill is more stable. **Do not fully fold the treadmill until it is completely assembled.**

Attach two Base Pads (82) to the base of the Uprights (84) with two 1" Tek Screws (83) as shown.

Insert an Extension Leg (89) into the base of the Uprights (84) as shown. Hold two Extension Leg Nuts (67) in the bottom of the Extension Leg. Next, insert two Extension Leg Bolts (65) into the top of the Extension Leg, and firmly tighten the Extension Leg Bolts into the Extension Leg Nuts.

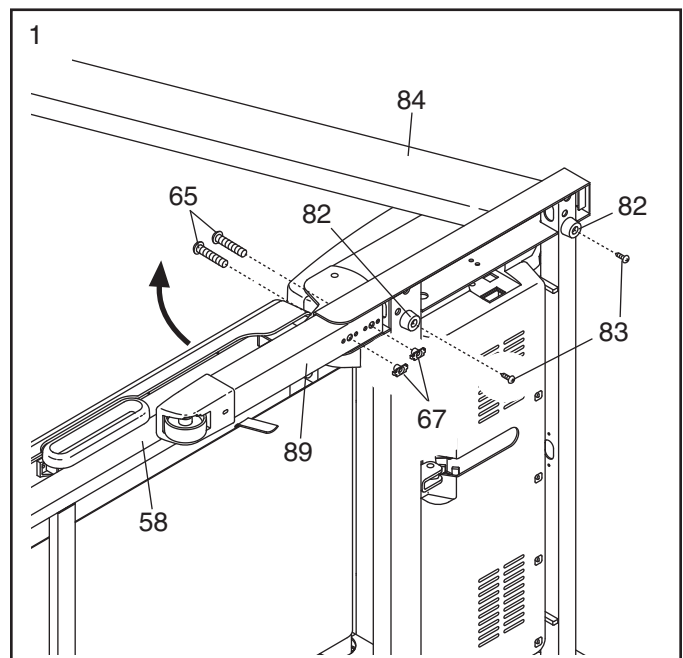

2. With the help of a second person, carefully tip the treadmill onto its other side. Partially fold the Frame (58) so the treadmill is more stable. **Do not fully fold the treadmill until it is completely assembled.**

Attach two Base Pads (82) to the base of the Uprights (84) with two 1" Tek Screws (83) as shown.

Insert the other Extension Leg (89) into the base of the Uprights (84) as shown. Hold two Extension Leg Nuts (67) in the bottom of the Extension Leg. Next, insert two Extension Leg Bolts (65) into the top of the Extension Leg, and firmly tighten the Extension Leg Bolts into the Extension Leg Nuts.

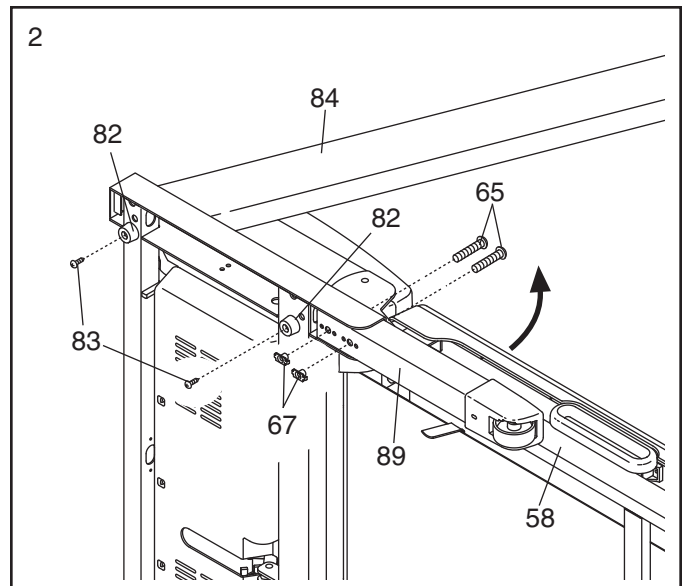

3. With the help of a second person, carefully raise the Uprights (84) to a vertical position.

Have the second person hold the console assembly near the Uprights (84) as shown. Look under the console assembly and locate the console wire.

Remove the band securing the Wire Harness (77) to the right Upright (84). Next, connect the Wire Harness to the Console Wire (66). **Make sure to connect the connectors properly (see the inset drawing). The connectors should slide together easily and snap into place.** If the connectors do not slide together easily and snap into place, turn one connector and then try again. **IF THE CONNECTORS ARE NOT CONNECTED PROPERLY, THE CONSOLE MAY BE DAMAGED WHEN THE POWER IS TURNED ON.**

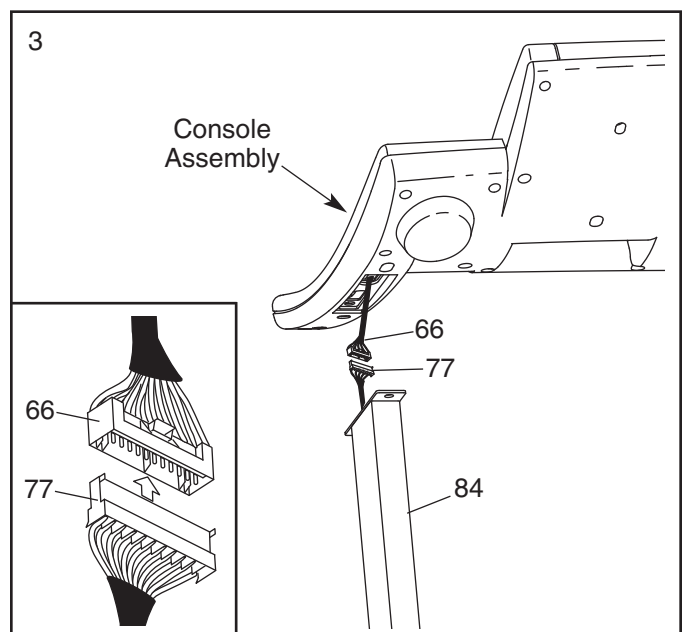

4. Look under the console assembly and locate the TV cable.

Remove the band securing the Upright TV Cable (104) to the left Upright (84). Connect the Upright TV Cable to the TV cable on the console assembly.

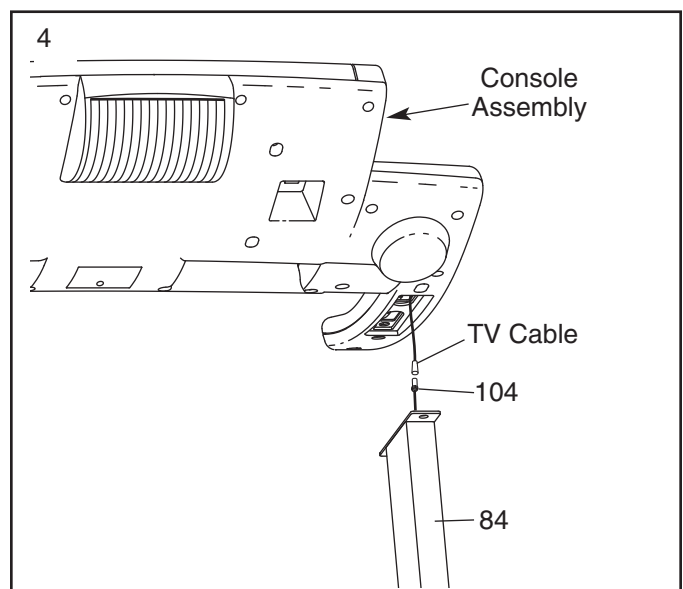



5. Insert the Console Wire Harness (77) and the TV cable into the Uprights (84).

Set the console assembly on the Uprights (84). **Be careful to avoid pinching the wires.** While a second person holds the console assembly, attach it with four Console Bolts (64) and four Star Washers (8) as shown; **start all four Console Bolts and then firmly tighten them.**

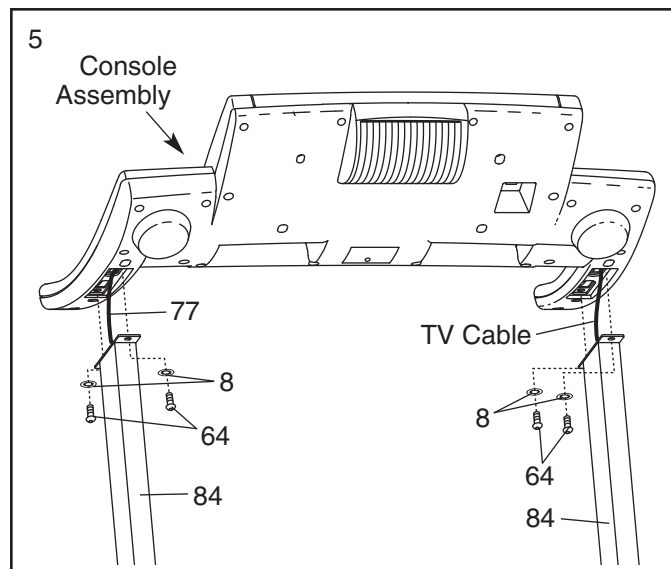

6. Attach the Latch Housing (73) to the left Upright (84) with two Screws (3); **start both Screws and then tighten them. Note: Make sure that the large hole in the Latch Housing is on the indicated side.**

Remove the knob from the pin. Make sure that the collar and the spring are on the pin. (Note: If there are two collars, place one on each side of the spring.) Next, insert the pin into the Latch Housing (73). Then, tighten the knob onto the pin.

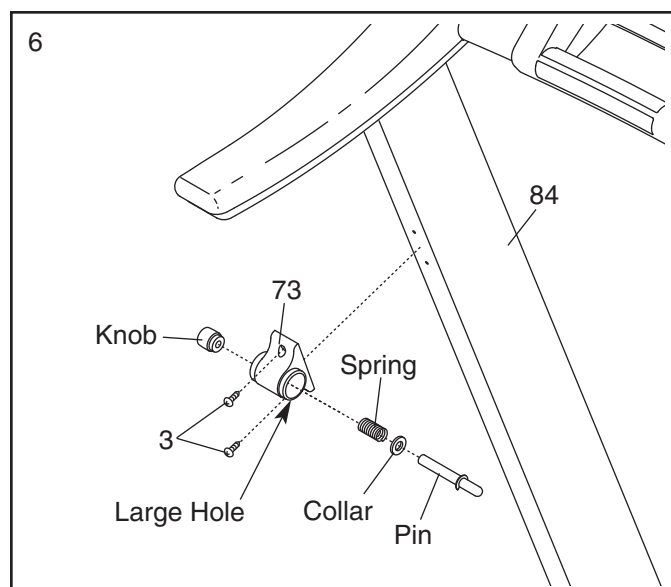

7. Note the location of the 75 ohm antenna terminal on the front of the treadmill. For the television to operate properly, an antenna, a CATV cable, or a VCR must be connected to the 75 ohm antenna terminal (see page 10).

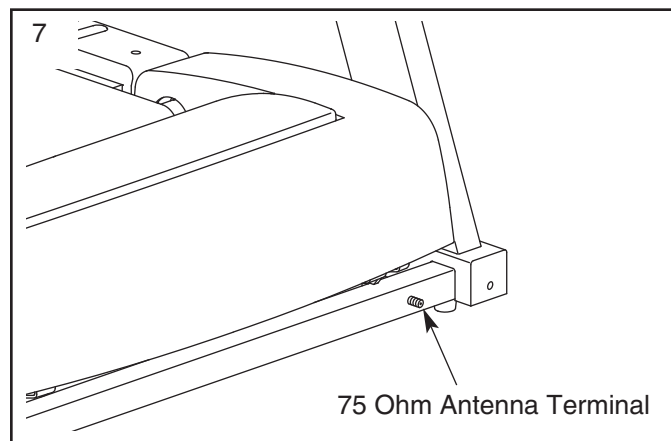

8. **Make sure that all parts are properly tightened before you use the treadmill.** If there are sheets of clear plastic on the treadmill decals, remove the plastic. To protect the floor or carpet, place a mat under the treadmill. Note: Extra hardware may be included. Keep the included hex key in a secure place; the large hex key is used to adjust the walking belt (see page 26).



If you purchase the optional chest pulse sensor (see page 22), follow the steps below to install the receiver included with the chest pulse sensor.

1. **Make sure that the key is removed from the console and that the power cord is unplugged.**

Remove the indicated Screws (3) from the back of the Console Base (85).

2. Connect the wire on the receiver (A) to the indicated wire on the Console (34). **Hold the receiver so the small cylinder is oriented as shown.** Next, remove the tape from the back of the receiver, and press the receiver onto the Console Base (85) **in the location shown.**

3. **Make sure that no wires are pinched.** Reattach the Console (34) with the Screws (3). Discard the other wires included with the receiver.

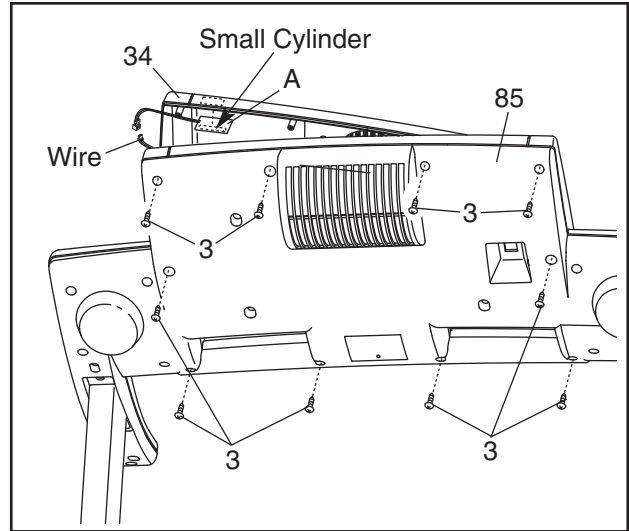

Before the personal television can be used, you must connect an antenna, a 75 ohm CATV cable, or a VCR to the 75 ohm antenna terminal on the treadmill frame. Note: No antenna, cable, or adapter is included.

### HOW TO CONNECT AN ANTENNA

#### Indoor Antenna

1. Place a VHF antenna in the desired location. Connect the 300 ohm flat wire from the antenna to a 300 ohm to 75 ohm adapter.

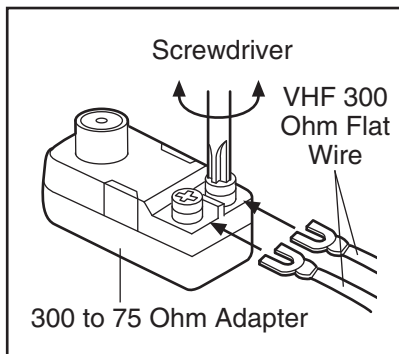

2. Push the 300 ohm to 75 ohm adapter onto the 75 ohm antenna terminal on the treadmill frame near the power cord.

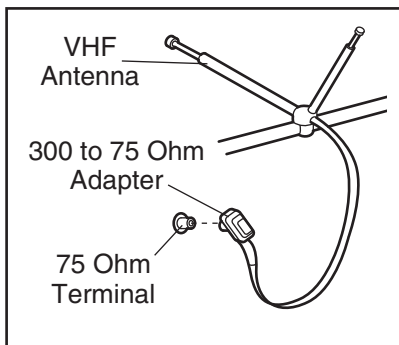

#### Outdoor Antenna

Note: Outdoor antennas are subject to weathering that can reduce signal quality. Inspect your antenna and the lead-in wiring before connecting the antenna.

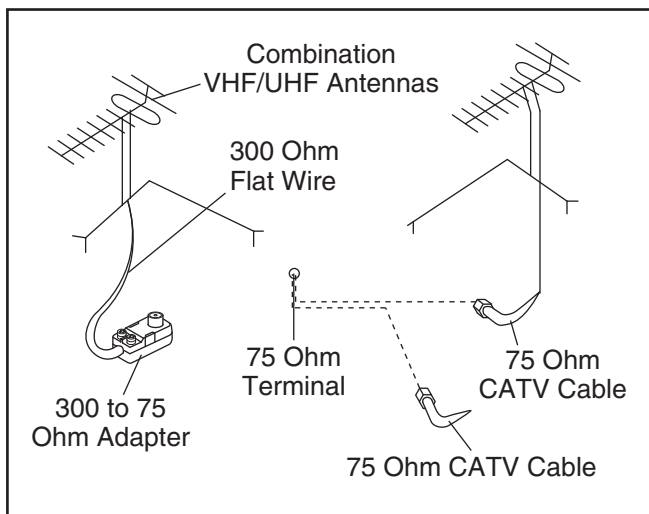

#### 300 Ohm Flat Wire

1. See the large drawing near the bottom of this page. Connect the 300 ohm flat wire from the antenna to a 300 ohm to 75 ohm adapter.
2. Push the 300 ohm to 75 ohm adapter onto the 75 ohm antenna terminal on the treadmill frame near the power cord.

#### 75 Ohm CATV Cable

1. See the large drawing near the bottom of this page. Connect the 75 ohm CATV cable from the antenna to the 75 ohm antenna terminal on the treadmill frame near the power cord.

### HOW TO CONNECT A 75 OHM CATV CABLE

1. Connect a 75 ohm CATV cable to the 75 ohm antenna terminal on the treadmill frame near the power cord.

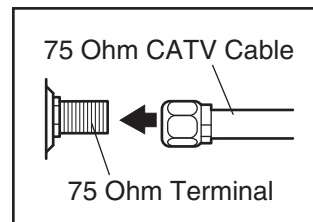

### HOW TO CONNECT A VCR

1. Connect one end of a 75 ohm CATV cable to the video output jack on your VCR.
2. Plug in the power cord of your VCR. See your VCR user's manual for proper grounding instructions.
3. Connect the 75 ohm CATV cable to the 75 ohm antenna terminal on the treadmill frame near the power cord.

Note: To operate the television with your VCR, make sure that the VCR is turned on, that channel 3 or 4 is selected, and that a videocassette is playing.

# OPERATION AND ADJUSTMENT

## THE PRE-LUBRICATED WALKING BELT

Your treadmill features a walking belt coated with high-performance lubricant. **IMPORTANT: Never apply silicone spray or other substances to the walking belt or the walking platform. Such substances will deteriorate the walking belt and cause excessive wear.**

## HOW TO PLUG IN THE POWER CORD

**⚠ DANGER:** Improper connection of the equipment-grounding conductor can result in an increased risk of electric shock. Check with a qualified electrician or serviceman if you are in doubt as to whether the product is properly grounded. Do not modify the plug provided with the product—if it will not fit the outlet, have a proper outlet installed by a qualified electrician.

Your treadmill, like any other type of sophisticated electronic equipment, can be seriously damaged by sudden voltage changes in your home's power. Voltage surges, spikes, and noise interference can result from weather conditions or from other appliances being turned on or off. **To decrease the possibility of your treadmill being damaged, always use a surge suppressor with your treadmill (see drawing 1 at the right).** To purchase a surge suppressor, see your local REEBOK dealer or call the toll-free telephone number on the front cover of this manual and order part number 146148, or see your local electronics store.

Use only a single-outlet surge suppressor that is UL 1449 listed as a transient voltage surge suppressor (TVSS). The surge suppressor must have a UL suppressed voltage rating of 400 volts or less and a minimum surge dissipation of 450 joules. The surge suppressor must be electrically rated for 120 volts AC and 15 amps. There must be a monitoring light on the surge suppressor to indicate whether it is functioning properly. Failure to use a properly functioning surge suppressor could result in damage to the control system of the treadmill. If the control system is damaged, the walking belt may change speed, accelerate or stop unexpectedly, which may result in a fall and serious injury.

**This product must be grounded.** If it should malfunction or break down, grounding provides a path of least resistance for electric current to reduce the risk of elec-

tric shock. This product is equipped with a cord having an equipment-grounding conductor and a grounding plug. **Plug the power cord into a surge suppressor, and plug the surge suppressor into an appropriate outlet that is properly installed and grounded in accordance with all local codes and ordinances. Important: The treadmill is not compatible with GFCI-equipped outlets.**

This product is for use on a nominal 120-volt circuit, and has a grounding plug that looks like the plug illustrated in drawing 1 below. A temporary adapter that looks like the adapter illustrated in drawing 2 may be used to connect the surge suppressor to a 2-pole receptacle as shown in drawing 2 if a properly grounded outlet is not available.

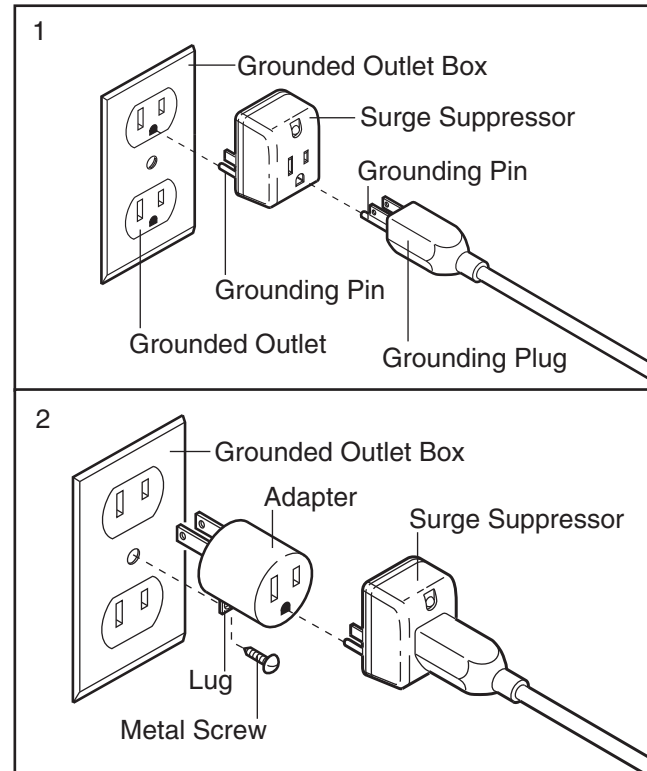

The temporary adapter should be used only until a properly grounded outlet (drawing 1) can be installed by a qualified electrician.

The green-colored rigid ear, lug, or the like extending from the adapter must be connected to a permanent ground such as a properly grounded outlet box cover. Whenever the adapter is used it must be held in place by a metal screw. **Some 2-pole receptacle outlet box covers are not grounded. Contact a qualified electrician to determine if the outlet box cover is grounded before using an adapter.**

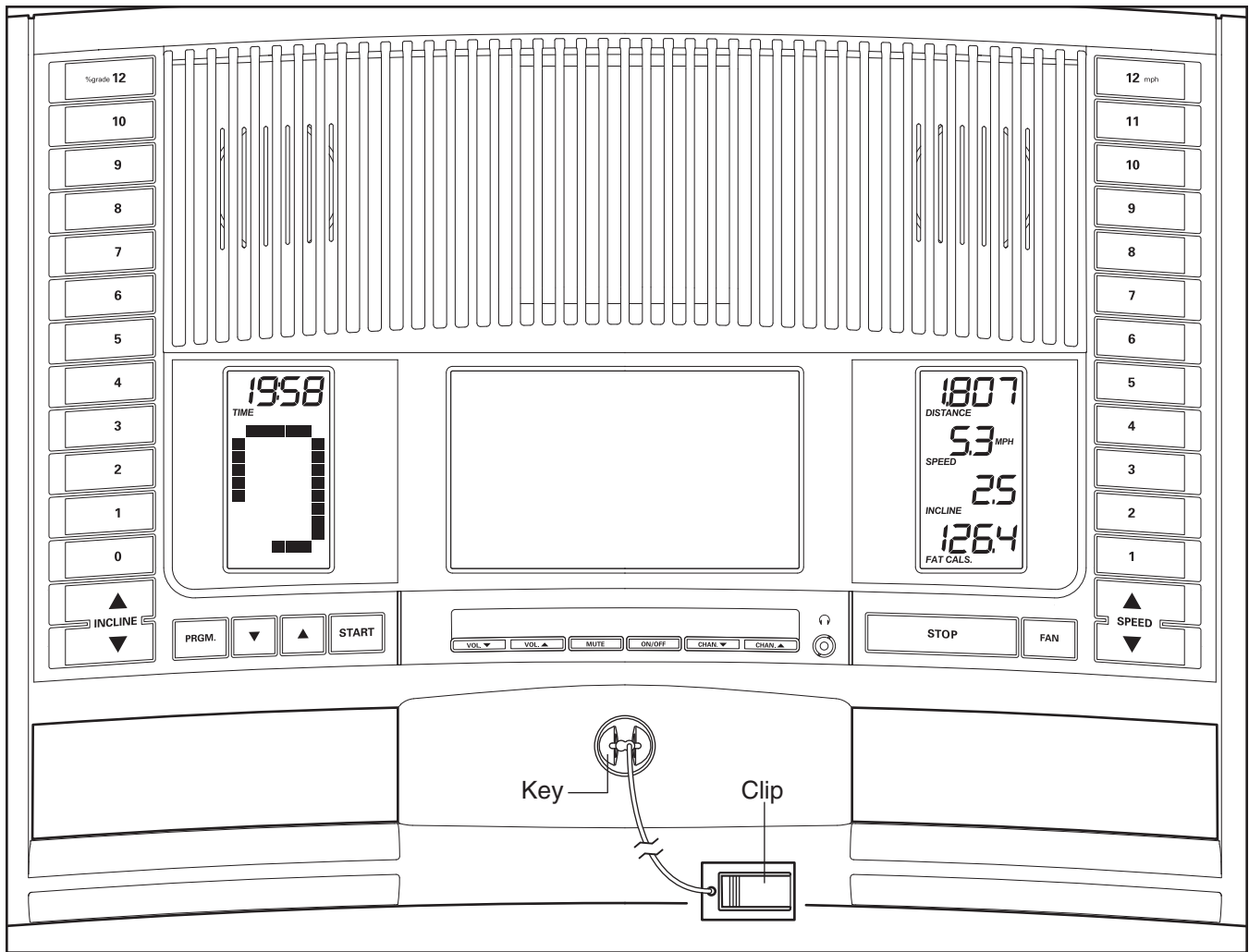

## FEATURES OF THE CONSOLE

The treadmill console offers an impressive array of features designed to make your workouts more effective and enjoyable. When the manual mode of the console is selected, the speed and incline of the treadmill can be changed with the touch of a button. As you exercise, the console will display continuous exercise feedback. You can even measure your heart rate using the handgrip pulse sensor or the optional chest pulse sensor (see page 22 for information about the optional chest pulse sensor).

In addition, the console offers eight preset programs. Each program automatically controls the speed and incline of the treadmill as it guides you through an effective workout. You can even create custom workout programs and store them in memory for future use.

Two heart rate programs are also offered. Each program automatically adjusts the speed and incline of the treadmill to keep your heart rate near target heart rate

settings while you exercise. Note: The heart rate programs require the use of the optional chest pulse sensor.

Whether you select the manual mode or a program, you can enjoy the shows of your choice on the personal television while you get in shape.

**To use the manual mode of the console**, follow the steps beginning on page 13. **To use a preset program**, see page 15. **To use a heart rate program**, see page 17. **To create and use a custom program**, see pages 19 and 20. **To operate the personal television**, see page 21.

Note: If there is a sheet of clear plastic on the face of the console, peel off the plastic. To prevent damage to the walking platform, wear clean athletic shoes while using the treadmill. The first time the treadmill is used, observe the alignment of the walking belt, and center the walking belt if necessary (see page 26).

## HOW TO TURN ON THE POWER

Plug in the power cord (see page 11).

Next, locate the reset/off circuit breaker near the power cord. Make sure that the circuit breaker is in the reset position.

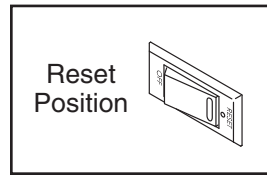

Next, stand on the foot rails of the treadmill. Find the clip attached to the key (see the drawing on page 12) and attach the clip securely to the waistband of your clothes. Then, insert the key into the console. After a moment, the displays will light, and after a few seconds, the television will turn on. **Important: In an emergency situation, the key can be pulled from the console, causing the walking belt to slow to a stop. Test the clip by carefully taking a few steps backward until the key is pulled from the console. If the key is not pulled from the console, adjust the position of the clip as needed.**

## HOW TO USE THE MANUAL MODE

### 1 Insert the key into the console.

See HOW TO TURN ON THE POWER above.

### 2 Select the manual mode.

When the key is inserted, the manual mode will be selected. If you have selected a program, reselect the manual mode by pressing the Program (PRGM.) button repeatedly until a track appears in the left display.

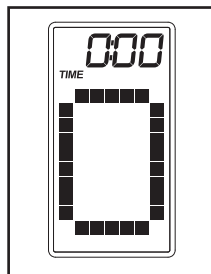

### 3 Start the walking belt.

To start the walking belt, press the Start button, the Speed increase button, or one of the twelve numbered Speed buttons.

If the Start button or the Speed increase button is pressed, the walking belt will begin to move at 1 mph. As you exercise, change the speed of the walking belt as desired by pressing the Speed increase and decrease buttons. Each time a button is pressed, the speed setting will change by 0.1 mph; if a button is held down, the speed setting will change in increments of 0.5 mph. Note: After the buttons are pressed, it may take a moment for the walking belt to reach the selected speed setting.

If one of the numbered Speed buttons is pressed, the walking belt will gradually increase in speed until it reaches the selected speed setting.

To stop the walking belt, press the Stop button. The time will begin to flash in the left display. To restart the walking belt, press the Start button, the Speed increase button, or one of the numbered Speed buttons.

### 4 Change the incline of the treadmill as desired.

To change the incline of the treadmill, press the Incline buttons. Each time a button is pressed, the incline will change by 0.5%. To change the incline setting quickly, press the numbered Incline buttons. Note: After the buttons are pressed, it may take a moment for the treadmill to reach the selected incline setting.

### 5 Follow your progress with the two displays.

**The left display**—This display will show the elapsed time. Note: When a program is selected (except for heart rate program 10 or a custom program), this display will show the time remaining in the program instead of the elapsed time.

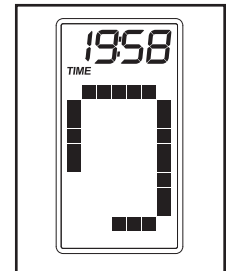

When the manual mode is selected, the left display will also show a track. As you exercise, the indicators around the track will appear in succession until the entire track appears. The track will then disappear the indicators will again begin to appear in succession.

**The right display**—This display will show the distance that you have walked or run, the speed of the walking belt, the incline level of the treadmill, your pace (in minutes per mile), and the approximate numbers of *calories* and *fat calories* you have burned (see FAT BURNING on page 28). This display will also show your heart rate when you use the handgrip pulse sensor or the optional chest pulse sensor.

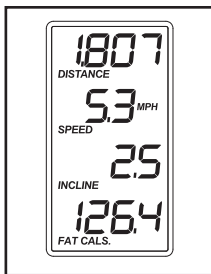

Note: The console can display speed and distance in either miles or kilometers. The letters “MPH” or “Km/H” will appear in the right display to show which unit of measurement is selected. To change the unit of measurement, see HOW TO USE THE INFORMATION MODE on page 21. **For simplicity, all instructions in this section refer to miles.**

To reset the displays, press the Stop button, remove the key, and then reinsert the key.

**6 Measure your heart rate if desired.**

Note: If you use the handgrip pulse sensor and the optional chest pulse sensor at the same time, the console will not display your heart rate accurately.

Before using the handgrip pulse sensor, remove the sheets of clear plastic from the metal contacts. In addition, make sure that your hands are clean.

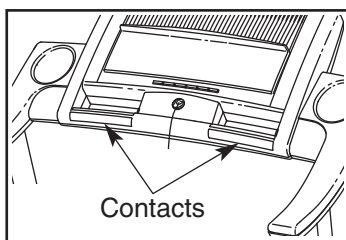

Next, hold the handgrip pulse sensor with your palms resting on the metal contacts; **avoid moving your hands**. When your pulse is detected, the heart-shaped indicator in the right display will flash each time your heart beats, one or two dashes (– –) will appear, and then your heart rate will be shown. **For the most accurate heart rate reading, continue to hold the contacts for about 15 seconds.**

**7 Turn on the fan if desired.**

To turn on the fan, press the Fan button. To turn on the fan at high speed, press the button a second time. To turn off the fan, press the button a third time. Note: If the fan is on when the walking belt is stopped, the fan will automatically turn off after a few minutes.

**8 When you are finished exercising, remove the key from the console.**

Step onto the foot rails, press the Stop button, and **adjust the incline of the treadmill to the lowest setting. The incline must be at the lowest setting when the treadmill is folded to the storage position or the treadmill will become damaged.** Next, remove the key from the console and put it in a secure place. **Note: If the displays remain lit after the key is removed, the console is in the “demo” mode. See HOW TO USE THE INFORMATION MODE on page 21 and turn off the demo mode.**

**When you are finished using the treadmill, switch the reset/off circuit breaker to the “off” position and unplug the power cord.**



## HOW TO USE A PRESET PROGRAM

### 1 Insert the key into the console.

See HOW TO TURN ON THE POWER on page 13.

### 2 Select a preset program.

To select a preset program, press the Program (PRGM.) button repeatedly until "P-1," "P-2," "P-3," "P-4," "P-5," "P-6," "P-7," or "P-8" appears in the right display. When a preset program is selected, the maximum speed setting of the program and the maximum incline setting will flash in the right display for a few seconds. The left display will show how long the program will last. A profile of the speed settings of the program will scroll across the matrix in the left display.

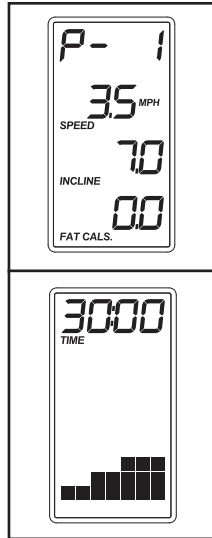

### 3 Press the Start button or the Speed increase button to start the program.

A moment after the button is pressed, the treadmill will automatically adjust to the first speed and incline settings of the program. Hold the handrails and begin walking.

Each preset program is divided into either 30 or 50 one-minute segments. One speed setting and one incline setting are programmed for each segment. (Note: The same speed setting and/or incline setting may be programmed for two or more consecutive segments.) The speed setting for the first segment will be shown in the flashing Current Segment column of the matrix. (The incline settings are not shown in the matrix.) The speed settings for the next few segments will be shown in the columns at the right.

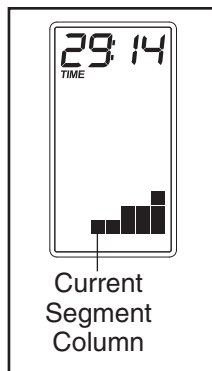

When only three seconds remain in the first segment of the program, both the Current Segment column and the column to the right will flash, and a series of tones will sound. If the speed and/or incline of the treadmill is about to change, the speed setting and/or the incline setting will flash in the right display to alert you. When the first segment ends, *all speed settings in the matrix will move one column to the left*. The speed setting for the second segment will then be shown in the flashing Current Segment column, and the treadmill will automatically adjust to the speed and incline settings for the second segment. Note: If all of the indicators in the Current Segment column are lit after the speed settings have moved to the left, *the speed settings may move downward* so that only the highest indicators appear in the matrix. If some indicators in the Current Segment column are not lit when the speed settings move to the left again, the speed settings will move back up.

The program will continue in this way until the speed setting for the last segment is shown in the Current Segment column and the last segment ends. The walking belt will then slow to a stop.

If the speed or incline setting is too high or too low at any time during the program, you can manually override the setting by pressing the Speed or Incline buttons. Every few times a Speed button is pressed, an additional indicator will appear or disappear in the Current Segment column. (If any of the columns to the right of the Current Segment column have the same number of indicators as the Current Segment column, an additional indicator may appear or disappear in those columns as well.) **Note: When the next segment of the program begins, the treadmill will automatically adjust to the speed and incline settings for the next segment.**

To stop the program at any time, press the Stop button. The time will begin to flash in the left display. To restart the program, press the Start button or the Speed increase button. The walking belt will begin to move at 1 mph. When the next segment of the program begins, the treadmill will automatically adjust to the speed and incline settings for the next segment.



**4 Follow your progress with the displays.**

See step 5 on pages 13 and 14.

**5 Measure your heart rate if desired.**

See step 6 on page 14.

**6 Turn on the fan if desired.**

See step 7 on page 14.

**7 When you are finished exercising, remove the key from the console.**

When the program ends, **make sure that the incline of the treadmill is at the lowest setting.**

Next, remove the key from the console and put it in a secure place. **Note: If the displays and various indicators remain lit after the key is removed, the console is in the “demo” mode. See HOW TO USE THE INFORMATION MODE on page 21 and turn off the demo mode.**

**When you are finished using the treadmill, switch the reset/off circuit breaker to the “off” position and unplug the power cord.**

## HOW TO USE A HEART RATE PROGRAM

During heart rate program 9, your heart rate will reach approximately 85% of your *age-predicted maximum heart rate*. (Note: Your age-predicted maximum heart rate is calculated by subtracting your age from 220. For example, if you are 30 years old, your age-predicted maximum heart rate is 190 beats per minute). During heart rate program 10, your heart rate will remain near a target heart rate setting that you select.

**CAUTION:** If you have heart problems, or if you are over 60 years of age and have been inactive, do not use the heart rate programs. If you are taking medication regularly, consult your physician to find whether the medication will affect your exercise heart rate.

Follow the steps below to use a heart rate program.  
**Note: You must wear the optional chest pulse sensor to use a heart rate program. While using the chest pulse sensor, do not use the handgrip pulse sensor.**

### 1 Put on the chest pulse sensor.

See page 22.

### 2 Insert the key into the console.

See HOW TO TURN ON THE POWER on page 13.

### 3 Select a heart rate program.

To select a heart rate program, press the Program (PRGM.) button repeatedly until “P-9” or “P-10” appears in the right display.

If heart rate program 9 is selected, a profile of the target heart rate settings of the program will appear in the matrix in the left display.

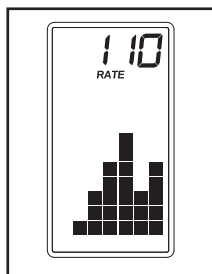

If heart rate program 10 is selected, a pulse symbol will scroll across the matrix in the left display. Each time a heartbeat is detected, a peak will appear.

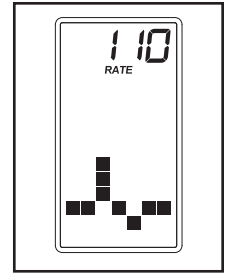

### 4 Enter a target heart rate setting for the program.

If heart rate program 9 is selected, the word “RATE” will appear in the left display and the maximum target heart rate setting of the program will begin to flash. If desired, change the maximum target heart rate setting by pressing the increase or decrease button below the matrix (see EXERCISE INTENSITY on page 28). Note: If the maximum target heart rate setting is changed, the intensity level of the entire program will change.

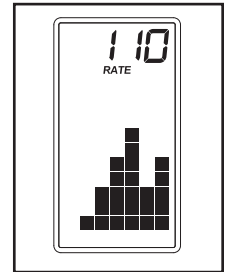

If heart rate program 10 is selected, the word “RATE” will appear in the left display and the target heart rate setting for the program will begin to flash. If desired, change the target heart rate setting by pressing the increase or decrease button below the matrix (see EXERCISE INTENSITY on page 28).

### 5 Press the Start button or the Speed increase button to start the program.

A moment after the button is pressed, the treadmill will automatically adjust to the first speed and incline settings of the program. Hold the handrails and begin walking.

Heart rate program 9 is divided into 30 one-minute segments. One target heart rate setting is programmed for each segment. (The same target heart rate setting may be programmed for two or more consecutive segments.)

Heart rate program 10 is divided into several one-minute segments. The same target heart rate setting is programmed for all segments. Note: For a shorter workout, simply stop the program before it ends.

**If heart rate program 9 is selected**, the target heart rate setting for the first segment will be shown in the flashing Current Segment column of the matrix. The target heart rate settings for the next several segments will be shown in the columns to the right. When only three seconds remain in the first segment of the program, both the Current Segment column and the column to the right will flash and a series of tones will sound.

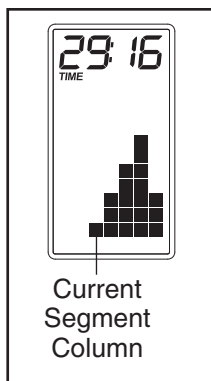

When the first segment ends, *all target heart rate settings will move one column to the left*. The target heart rate setting for the second segment will then be shown in the flashing Current Segment column.

**During both heart rate programs**, the console will regularly compare your heart rate to the target heart rate setting for the current segment. If your heart rate is too far below or above the target heart rate setting, the speed of the walking belt will automatically increase or decrease to bring your heart rate closer to the target heart rate setting.

If the speed or incline setting is too high or too low at any time during the program, you can adjust the

setting with the Speed or Incline buttons. However, when the console compares your heart rate to the target heart rate setting, the speed of the treadmill may automatically change to bring your heart rate closer to the target heart rate setting.

If your pulse is not detected during the program, the letters “PLS” will flash in the right display and the speed of the treadmill may automatically decrease.

To stop the program at any time, press the Stop button. To restart the program, press the Start button or the Speed increase button. The walking belt will begin to move at 1 mph. When the console compares your heart rate to the target heart rate setting, the speed of the treadmill may automatically change to bring your heart rate closer to the target heart rate setting.

## **6 Follow your progress with the displays.**

See step 5 on pages 13 and 14.

## **7 Turn on the fan if desired.**

See step 7 on page 14.

## **8 When you are finished exercising, remove the key from the console.**

See step 7 on page 16.

## HOW TO CREATE A CUSTOM PROGRAM

### 1 Insert the key into the console.

See HOW TO TURN ON THE POWER on page 13.

### 2 Select a custom program.

To select a custom program, press the Program (PRGM.) button repeatedly until “P-11” or “P-12” appears in the right display.

If the custom program has not yet been defined, three columns of indicators will scroll across the matrix in the left display. **If more than three columns of indicators appear, see HOW TO USE A CUSTOM PROGRAM on page 20.**

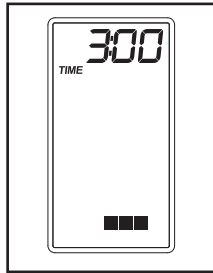

### 3 Press the Start button or the Speed increase button and program the desired speed and incline settings.

A moment after the button is pressed, the walking belt will begin to move. Hold the handrails and begin walking.

See the matrix in the left display. Each custom program is divided into one-minute segments. One speed setting and one incline setting can be programmed for each segment. The speed setting for the first segment will be shown in the flashing Current Segment column of the matrix. (The incline set-

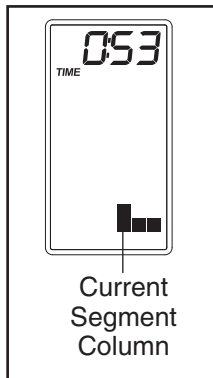

tings are not shown in the matrix.) To program a speed setting and an incline setting for the first segment, simply adjust the speed and incline of the treadmill as desired by pressing the Speed and Incline buttons. Every few times a Speed button is pressed, an additional indicator will appear or disappear in the Current Segment column.

When the first segment of the program ends, the current speed setting and the current incline setting will be stored in memory. *The three columns of indicators will then move one column to the left, and the speed setting for the second segment will be shown in the flashing Current Segment column.* Program a speed setting and an incline setting for the second segment as described above.

Continue programming speed and incline settings for as many segments as desired; custom programs can have up to forty segments. When you are finished with your workout, press the Stop button twice. The speed and incline settings that you have programmed and the number of segments that you have programmed will then be saved in memory.

### 4 When you are finished exercising, remove the key from the console.

See step 7 on page 16.

## HOW TO USE A CUSTOM PROGRAM

### 1 Insert the key into the console.

See HOW TO TURN ON THE POWER on page 13.

### 2 Select a custom program.

To select a custom program, press the Program (PRGM.) button repeatedly until "P-11" or "P-12" appears in the right display.

When a custom program is selected, the maximum speed setting of the program and the maximum incline setting will flash in the right display for a few seconds. The left display will show how long the program will last. A profile of the speed settings of the program will scroll across the matrix in the left display. **Note: If only three columns of indicators appear, see HOW TO CREATE A CUSTOM PROGRAM on page 19.**

### 3 Press the Start button or the Speed increase button to start the program.

A moment after the button is pressed, the treadmill will automatically adjust to the first speed and incline settings that you programmed previously. Hold the handrails and begin walking.

Each custom program is divided into several one-minute segments. One speed setting and one incline setting are programmed for each segment. The speed setting for the first segment will be shown in the flashing Current Segment column of the matrix. (The incline settings are not shown in the matrix.) The speed settings for the next few segments will be shown in the columns to the right.

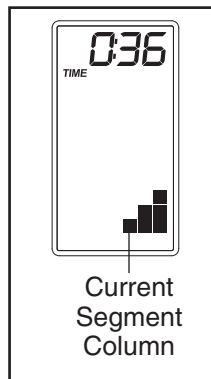

When only three seconds remain in the first segment of the program, both the Current Segment column and the column to the right will flash, a se-

ries of tones will sound, the speed setting and the incline setting will flash in the right display, and *all speed settings will move one column to the left.* The speed setting for the second segment will then be shown in the flashing Current Segment column and the treadmill will automatically adjust to the second speed and incline settings that you programmed previously.

The program will continue until the speed setting for the last segment is shown in the Current Segment column and the last segment ends. The walking belt will then slow to a stop.

If desired, you can redefine the program while using it. **To change the speed or incline setting during the current segment,** simply press the Speed or Incline buttons. When the current segment ends, the new setting will be saved in memory. **To increase the length of the program,** first wait until the program ends. Then, press the Start button, and program speed and incline settings for as many additional segments as desired. When you have added as many segments as desired, press the Stop button twice. **To decrease the length of the program,** press the Stop button twice at any time before the program ends.

To stop the program at any time, press the Stop button. The time will begin to flash in the left display. To restart the program, press the Start button or the Speed increase button.

### 4 Follow your progress with the displays.

See step 5 on pages 13 and 14.

### 5 Measure your heart rate if desired.

See step 6 on page 14.

### 6 Turn on the fan if desired.

See step 7 on page 14.

### 7 When you are finished exercising, remove the key from the console.

See step 7 on page 16.

## HOW TO OPERATE THE PERSONAL TELEVISION

**IMPORTANT:** Before operating the television, you must connect an antenna, a 75 ohm CATV cable, or a VCR to the 75 ohm antenna terminal on the treadmill. See page 10 for instructions.

Follow the steps below to operate the television.

### 1 Insert the key into the console.

See HOW TO TURN ON THE POWER on page 13.

### 2 Turn on the television.

When the key is inserted, the television will automatically turn on. If you have turned off the television, turn it on by pressing the On/Off button.

### 3 Press the Channel (CHAN.) buttons to select the desired channel.

When the television is turned on, the screen will show the last channel that was selected. To select a different channel, press the Channel buttons. The selected channel number will appear on the screen for a few seconds. Note: The television is equipped with a channel memorizing function that allows you to go directly from the current channel to the next channel saved in memory. Before channels can be selected in this way, they must be saved in the television's memory. See HOW TO USE THE INFORMATION MODE at the right.

### 4 Press the Volume (VOL.) buttons to adjust the volume.

When either Volume button is pressed, the volume level indicator will appear on the screen for a few seconds. To temporarily mute the sound, press the Mute button. Press the Mute button again to listen to the television. Note: To use earphones or headphones (not included), plug them into the headphone jack on the console.

### 5 When you are finished using the television, press the On/Off button.

Press the On/Off button to turn off the television. Note: Removing the key from the console will also turn off the television.

## HOW TO USE THE INFORMATION MODE

The console features an information mode that allows you to view treadmill usage information, select a system of measurement for the console, and turn on and turn off the demo mode. The information mode also allows you to adjust the settings of the television and to save channels into the television's memory.

Follow the steps below to use the information mode.

### 1 Hold down the Stop button while inserting the key into the console.

When the information mode is selected, the upper part of the right display will show the total number of miles or kilometers that the walking belt has moved, and the lower part of the display will show the total number of hours that the treadmill has been used.

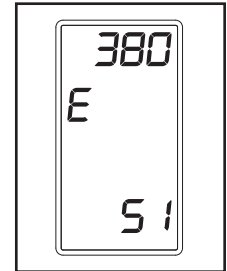

In addition, the right display will show the letter "E" for English miles or the letter "M" for metric kilometers. Press the Speed increase button to change the unit of measurement if desired.

**IMPORTANT:** If the letter "d" appears in the right display, the "demo" mode is selected. This mode is intended to be used only when a treadmill is displayed in a store. When the demo mode is selected, the power cord can be plugged in, the key can be removed from the console, and the displays and indicators on the console will automatically light in a preset sequence. The buttons on the console will not function. **If a "d" appears in the right display when the information mode is selected, press the Speed decrease button.**

### 2 Press the On/Off button and adjust the brightness, contrast, color, sharpness, and/or hue of the television.

A few seconds after the On/Off button is pressed, the brightness level indicator will appear on the television screen. Press the Volume buttons repeatedly to adjust the brightness setting if desired.

Next, press the Channel buttons repeatedly until the contrast, color, sharpness, or hue level indicator appears. Adjust each setting, if desired, by pressing the Volume buttons.

**3 Press the On/Off button again and add or delete channels.**

After all valid channels available in your area have been saved into the television's memory (see step 5 below), you can manually add channels or delete unwanted channels.

To add or delete a channel, first press the Channel buttons until the desired channel number appears on the screen. Then, press the Volume increase button to add the channel, or the Volume decrease button to delete the channel. Continue this process until you have added all desired channels and deleted all unwanted channels.

**4 Press the On/Off button again and select an antenna connection or a cable connection.**

After the On/Off button is pressed, press the Volume decrease button to select the Air setting, the Volume increase button to select the Standard Cable setting, the Channel decrease button to select the Cable IRC setting, or the Channel increase button to select the Cable HRC setting. Note: The setting that you select will **not** appear on the screen. If you have connected an antenna to the treadmill, the Air setting should be selected. If you have connected a CATV cable, one of the three Cable settings should be selected; try all three Cable settings, if necessary, to find the best setting.

**5 Press the On/Off button again and save channels into the television's memory.**

When the On/Off button is pressed, the television will begin scanning all of the channels available in

your area. When no broadcast signal is detected on a channel, the channel will be skipped. When a broadcast signal is detected, the channel will be saved into memory and the next channel will be selected. This process will continue until the highest channel is reached. **Do not remove the key while the television is scanning channels.**

**6 When you are finished using the information mode, remove the key.**

To exit the information mode at any time (except while the television is scanning channels), remove the key from the console.

**THE OPTIONAL CHEST PULSE SENSOR**

An optional chest pulse sensor provides hands-free operation and allows you to use the console's heart rate programs. **To purchase the optional chest pulse sensor, call the toll-free telephone number on the front cover of this manual.**

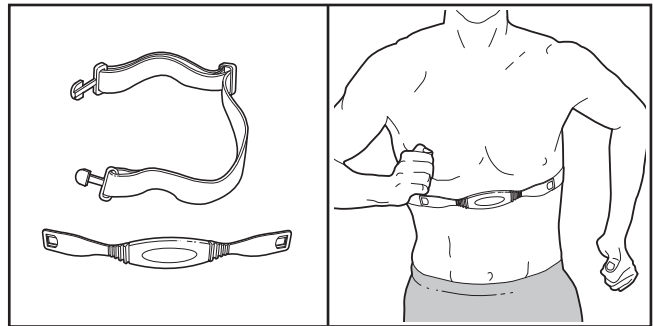



# HOW TO FOLD AND MOVE THE TREADMILL

## HOW TO FOLD THE TREADMILL FOR STORAGE

Before folding the treadmill, adjust the incline to the lowest position. If this is not done, the treadmill may be permanently damaged. Next, unplug the power cord. **CAUTION:** You must be able to safely lift 45 pounds (20 kg) to raise, lower, or move the treadmill.

1. Hold the metal frame firmly in the location shown by the arrow at the right. **CAUTION:** To decrease the possibility of injury, do not lift the treadmill by the plastic foot rails. Make sure you bend your legs and keep your back straight. As you raise the treadmill, make sure to lift with your legs rather than your back. Raise the treadmill about halfway to the vertical position.

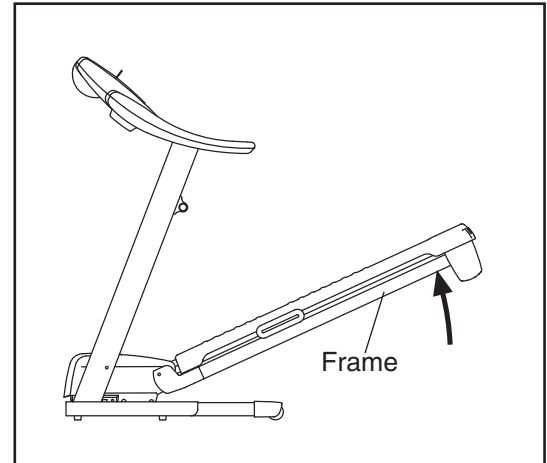

2. Move your right hand to the position shown and hold the treadmill firmly. Using your left hand, pull the latch knob to the left and hold it. Raise the treadmill until the catch is aligned with the latch pin. Slowly release the latch knob. **Make sure that the latch pin is fully resting on the catch.**

To protect the floor or carpet from damage, place a mat under the treadmill. Keep the treadmill out of direct sunlight. Do not leave the treadmill in the storage position in temperatures above 85° Fahrenheit.

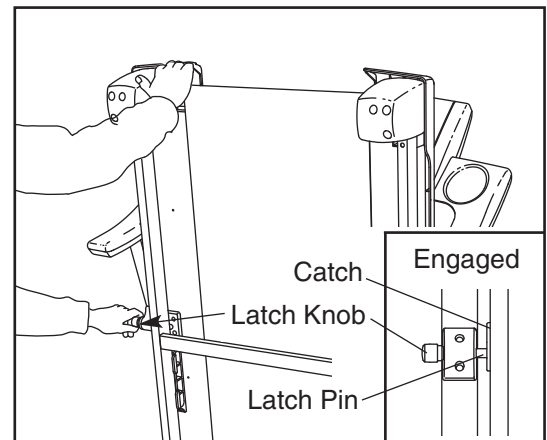

## HOW TO MOVE THE TREADMILL

Before moving the treadmill, convert the treadmill to the storage position as described above. **Make sure that the latch pin is fully resting on the catch.**

1. Hold the upper ends of the handrails. Place one foot against one of the wheels.
2. Tilt the treadmill back until it rolls freely on the front wheels. Carefully move the treadmill to the desired location. **To reduce the risk of injury, use extreme caution while moving the treadmill. Do not move the treadmill over an uneven surface.**
3. Place one foot against one of the wheels, and carefully lower the treadmill until it is resting in the storage position.

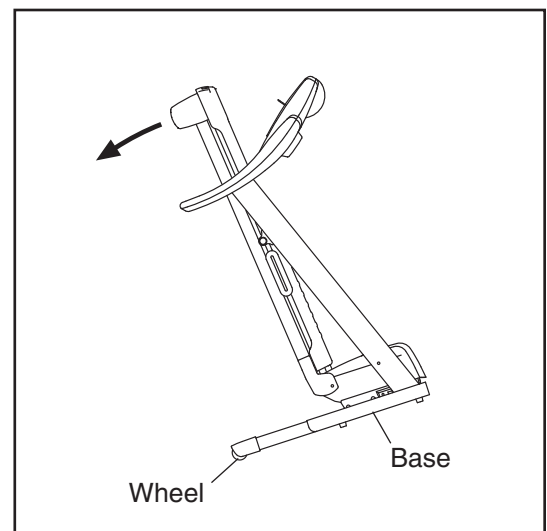

## HOW TO LOWER THE TREADMILL FOR USE

1. Hold the upper end of the treadmill with your right hand. Pull the latch knob to the left and hold it. Pivot the frame down until the catch is past the latch pin.

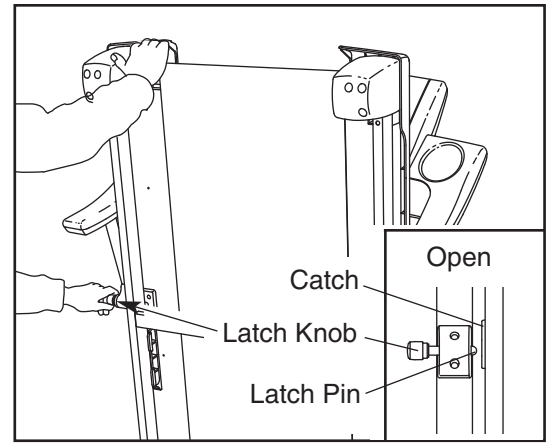

2. **Hold the metal frame firmly with both hands**, and lower the treadmill to the floor. **CAUTION: To decrease the possibility of injury, do not lower the treadmill by gripping only the plastic foot rails. Do not drop the frame to the floor. Make sure to bend your legs and keep your back straight.**

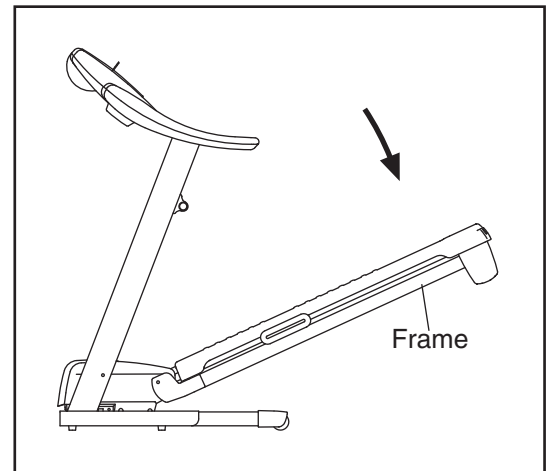

# TROUBLESHOOTING

Most treadmill problems can be solved by following the steps below. Find the symptom that applies, and follow the steps listed. If further assistance is needed, please call the toll-free telephone number on the front cover of this manual.

## PROBLEM: The power does not turn on

**SOLUTION:** a. Make sure that the power cord is plugged into a surge suppressor, and that the surge suppressor is plugged into a properly grounded outlet (see page 11). Use only a single-outlet surge suppressor that meets all of the specifications described on page 11. Important: The treadmill is not compatible with GFCI-equipped outlets.

b. After the power cord has been plugged in, make sure that the key is inserted into the console.

c. Check the reset/off circuit breaker located on the treadmill frame near the power cord. If the switch protrudes as shown, the circuit breaker has tripped. To reset the circuit breaker, wait for five minutes, and then press the switch back in.

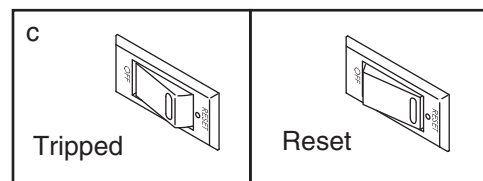

## PROBLEM: The power turns off during use

**SOLUTION:** a. Check the reset/off circuit breaker (see the drawing above). If the circuit breaker has tripped, wait for five minutes and then press the switch back in.

b. Make sure that the power cord is plugged in. If the power cord is plugged in, unplug it, wait for five minutes, and then plug it back in.

c. Remove the key from the console. Reinsert the key into the console.

d. If the treadmill still will not run, see the front cover of this manual.

## PROBLEM: The incline of the treadmill does not change correctly

**SOLUTION:** a. With the key in the console, press one of the Incline buttons. **While the incline is changing, remove the key.** After a few seconds, reinsert the key. The treadmill will automatically rise to the maximum incline level and then return to the minimum level. This will recalibrate the incline system.

## PROBLEM: The display of the console does not function properly

**SOLUTION:** a. Remove the key from the console and **UNPLUG THE POWER CORD.** Next, carefully lower the Uprights (84). Remove the two indicated 3/4" Screws (2). Note: A phillips screwdriver with at least an 8" shaft is needed.

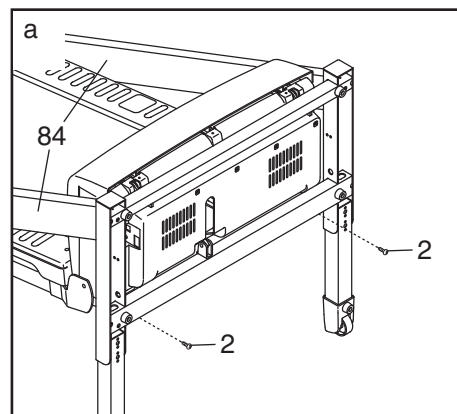

Raise the Uprights (84) to the vertical position. Remove the three Hood Screws (7) from the Hood (41), and carefully pivot the Hood off.

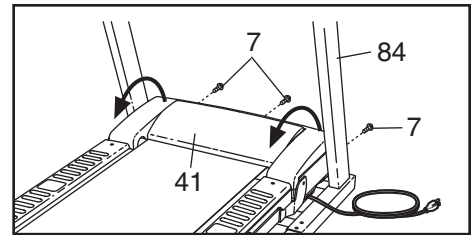

Locate the Reed Switch (63) and the Magnet (46) on the left side of the Pulley (47). Turn the Pulley until the Magnet is aligned with the Reed Switch. **Make sure that the gap between the Magnet and the Reed Switch is about 1/8".** If necessary, move the Reed Switch slightly using a slotted screwdriver. Reattach the Motor Hood (not shown); make sure that the Hood Screws (not shown) are inserted into the same holes from which they were removed. Run the treadmill for a few minutes to check for a correct speed reading.

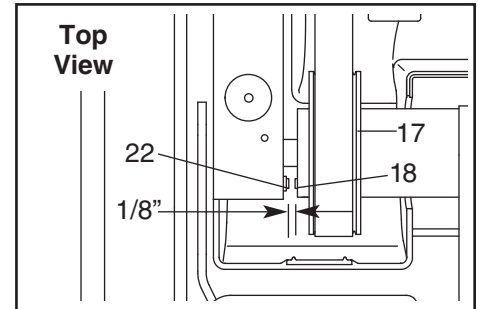

**PROBLEM: The walking belt slows when walked on**

**SOLUTION:** a. Use only a single-outlet surge suppressor that meets all of the specifications described on page 11.

b. If the walking belt is overtightened, treadmill performance may decrease and the walking belt may become damaged. Remove the key and **UNPLUG THE POWER CORD**. Using the hex key, turn both rear roller bolts counterclockwise, 1/4 of a turn. When the walking belt is properly tightened, you should be able to lift each edge of the walking belt 3 to 4 inches off the walking platform. Be careful to keep the walking belt centered. Then, plug in the power cord, insert the key, and run the treadmill for a few minutes. Repeat until the walking belt is properly tightened.

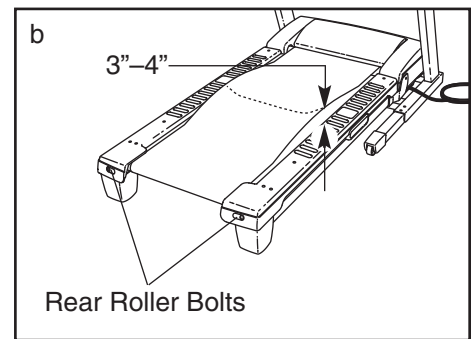

c. If the walking belt still slows when walked on, please see the front cover of this manual.

**PROBLEM: The walking belt is off-center or slips when walked on**

**SOLUTION:** a. **If the walking belt is off-center**, first remove the key and **UNPLUG THE POWER CORD**. **If the walking belt has shifted to the left**, use the hex key to turn the left rear roller bolt clockwise 1/2 of a turn; **if the walking belt has shifted to the right**, turn the left bolt counterclockwise 1/2 of a turn. Be careful not to overtighten the walking belt. Then, plug in the power cord, insert the key, and run the treadmill for a few minutes. Repeat until the walking belt is centered.

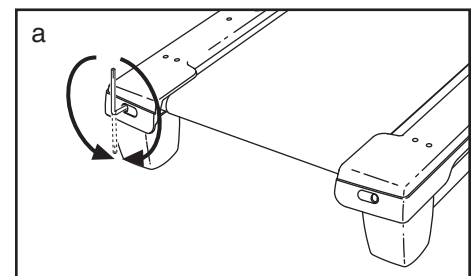

b. **If the walking belt slips when walked on**, first remove the key and **UNPLUG THE POWER CORD**. Using the hex key, turn both rear roller bolts clockwise, 1/4 of a turn. When the walking belt is correctly tightened, you should be able to lift each edge of the walking belt 3 to 4 inches off the walking platform. Be careful to keep the walking belt centered. Then, plug in the power cord, insert the key, and carefully walk on the treadmill for a few minutes. Repeat until the walking belt is properly tightened.

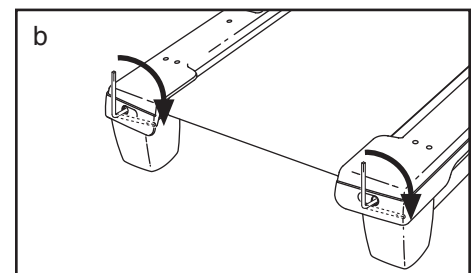

**PROBLEM: Television reception is poor**

**SOLUTION:** a. For the television to operate properly, good reception is necessary. If you are using an antenna, make sure that it is properly connected and adjusted for optimal reception. (See HOW TO CONNECT AN ANTENNA on page 10.)

b. Check for the problems listed below and follow the applicable instructions.

- Ignition (black spots or horizontal streaks that appear or a picture that flutters or drifts)—Usually this is caused by interference from automobile ignition systems, neon lamps, electric drifts, or other electric appliances. Try changing the position of the treadmill or other electric appliances to correct the problem.
- Ghosts—Ghosts are caused by the television signal following two paths—one is the direct path and the other is reflected from tall buildings, hills, or other objects. Change the direction or position of the antenna to improve reception.
- Blue Screen—If the treadmill is located in the fringe area of a television station where the signal is weak, the picture may be of poor quality or a blue screen may appear. If the signal is weak, it may be necessary to install an external antenna to improve the picture.

Note: If one of these symptoms appears when the cable from a CATV company is connected, the symptom may be caused by the local company broadcast.

# CONDITIONING GUIDELINES

**⚠️ WARNING:** Before beginning this or any exercise program, consult your physician. This is especially important for individuals over the age of 35 or individuals with pre-existing health problems.

The pulse sensor is not a medical device. Various factors, including your movement, may affect the accuracy of heart rate readings. The sensor is intended only as an exercise aid in determining heart rate trends in general.

The following guidelines will help you to plan your exercise program. For more detailed exercise information, obtain a reputable book or consult your physician.

## EXERCISE INTENSITY

Whether your goal is to burn fat or to strengthen your cardiovascular system, the key to achieving the desired results is to exercise with the proper intensity. The proper intensity level can be found by using your heart rate as a guide. The chart below shows recommended heart rates for fat burning and aerobic exercise.

AEROBIC	165	155	145	140	130	125	115
MAX FAT BURN	145	138	130	125	118	110	103
FAT BURN	125	120	115	110	105	95	90
Age	20	30	40	50	60	70	80

To find the proper heart rate for you, first find your age near the bottom of the chart (ages are rounded off to the nearest ten years). Next, find the three numbers above your age. The three numbers define your “training zone.” The lower two numbers are recommended heart rates for fat burning; the higher number is the recommended heart rate for aerobic exercise.

## Fat Burning

To burn fat effectively, you must exercise at a relatively low intensity level for a sustained period of time. During the first few minutes of exercise, your body uses easily accessible *carbohydrate calories* for energy. Only after the first few minutes does your body begin to use stored *fat calories* for energy. If your goal

is to burn fat, adjust the speed and incline of the treadmill until your heart rate is near the lowest number in your training zone.

For maximum fat burning, adjust the speed and incline of the treadmill until your heart rate is near the middle number in your training zone.

## Aerobic Exercise

If your goal is to strengthen your cardiovascular system, your exercise must be “aerobic.” Aerobic exercise is activity that requires large amounts of oxygen for prolonged periods of time. This increases the demand on the heart to pump blood to the muscles, and on the lungs to oxygenate the blood. For aerobic exercise, adjust the speed and incline of the treadmill until your heart rate is near the highest number in your training zone.

## WORKOUT GUIDELINES

Each workout should include the following three parts:

**A Warm-up**—Start each workout with 5 to 10 minutes of stretching and light exercise. A proper warm-up increases your body temperature, heart rate and circulation in preparation for exercise.

**Training Zone Exercise**—After warming up, increase the intensity of your exercise until your heart rate is in your training zone for 20 to 60 minutes. (During the first few weeks of your exercise program, do not keep your heart rate in your training zone for longer than 20 minutes.) Breathe regularly and deeply as you exercise—never hold your breath.

**A Cool-down**—Finish each workout with 5 to 10 minutes of stretching to cool down. This will increase the flexibility of your muscles and will help prevent post-exercise problems.

## EXERCISE FREQUENCY

To maintain or improve your condition, complete three workouts each week, with at least one day of rest between workouts. After a few months, you may complete up to five workouts each week if desired. The key to success is to make exercise a regular and enjoyable part of your everyday life.

## SUGGESTED STRETCHES

The correct form for several basic stretches is shown at the right. Move slowly as you stretch—never bounce.

### 1. Toe Touch Stretch

Stand with your knees bent slightly and slowly bend forward from your hips. Allow your back and shoulders to relax as you reach down toward your toes as far as possible. Hold for 15 counts, then relax. Repeat 3 times. Stretches: Hamstrings, back of knees and back.

### 2. Hamstring Stretch

Sit with one leg extended. Bring the sole of the opposite foot toward you and rest it against the inner thigh of your extended leg. Reach toward your toes as far as possible. Hold for 15 counts, then relax. Repeat 3 times for each leg. Stretches: Hamstrings, lower back and groin.

### 3. Calf/Achilles Stretch

With one leg in front of the other, reach forward and place your hands against a wall. Keep your back leg straight and your back foot flat on the floor. Bend your front leg, lean forward and move your hips toward the wall. Hold for 15 counts, then relax. Repeat 3 times for each leg. To cause further stretching of the achilles tendons, bend your back leg as well. Stretches: Calves, achilles tendons and ankles.

### 4. Quadriceps Stretch

With one hand against a wall for balance, reach back and grasp one foot with your other hand. Bring your heel as close to your buttocks as possible. Hold for 15 counts, then relax. Repeat 3 times for each leg. Stretches: Quadriceps and hip muscles.

### 5. Inner Thigh Stretch

Sit with the soles of your feet together and your knees outward. Pull your feet toward your groin area as far as possible. Hold for 15 counts, then relax. Repeat 3 times. Stretches: Quadriceps and hip muscles.

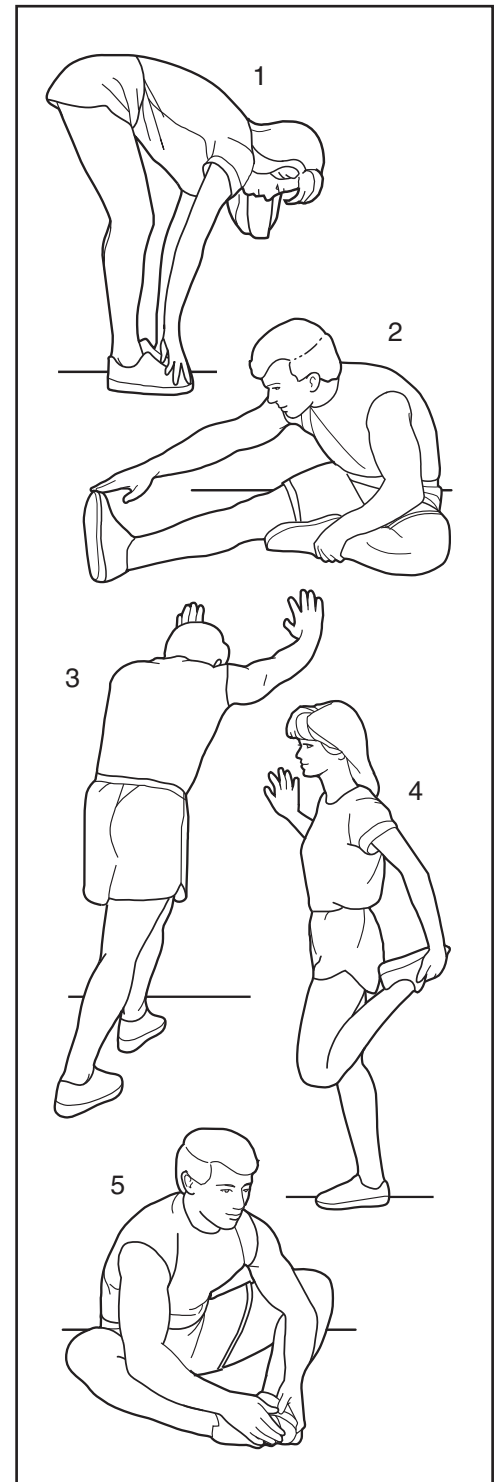



# PART LIST—Model No. RBTL09906.0

R1206A

To locate the parts listed below, see the EXPLODED DRAWING starting on page 32.

Key No.	Qty.	Description	Key No.	Qty.	Description
1	2	Foot Rail Cover	49	1	Walking Platform
2	6	3/4" Screw	50	6	Rear Roller Washer/Isolator Washer
3	51	Screw	51	1	Rear Roller
4	1	Catch	52	1	Left Rear Endcap
5	10	Foot Rail Screw	53	2	Rear Roller Bolt
6	2	Isolator	54	1	Right Rear Endcap
7	5	Hood Screw	55	1	Hex Key
8	4	Star Washer	56	2	Lift Frame Nut
9	2	Platform Bolt, Back	57	1	Front Roller Ground Wire
10	3	Platform Bolt, Front/Idler Pulley Bolt	58	1	Frame
11	4	Belt Guide Screw	59	1	Belly Pan
12	2	Belt Guide	60	1	Reed Switch Clip
13	1	Left Handrail	61	2	Static Decal
14	1	Right Handrail	62	1	Power Cord Grommet
15	2	Frame Pivot Bolt	63	1	Reed Switch
16	1	Left Foot Rail	64	4	Console Bolt
17	1	Right Foot Rail	65	4	Extension Leg Bolt
18	1	Idler Arm Pivot Nut	66	1	Console Wire
19	1	Idler Arm Bushing	67	4	Extension Leg Nut
20	1	Console Frame Support	68	2	Caution Decal
21	1	Latch Pin Assembly	69	1	Warning Decal
22	2	Idler Arm	70	4	Platform Nut
23	1	Idler Spring	71	7	Cable Tie
24	2	Motor Bolt	72	1	Lower Incline Motor Pin
25	1	Idler Arm Bolt	73	1	Latch Housing
26	1	Motor Belt	74	1	Tie Clamp
27	1	Drive Motor	75	1	Releasable Tie
28	2	Frame Washer	76	1	Access Door
29	4	U-nut	77	1	Wire Harness
30	1	Idler Arm Washer	78	2	Extension Leg Endcap
31	2	Lift Frame Bolt	79	1	Key/Clip
32	3	Lock Nut	80	2	Front Wheel
33	8	1/2" Screw	81	2	Wheel Pin
34	1	Console	82	4	Base Pad
35	2	Fan Screw	83	6	1" Tek Screw
36	1	Power Cord	84	1	Upright
37	1	Console Fan	85	1	Console Base
38	1	Controller	86	1	Incline Motor Pin, Upper
39	1	Reset/Off Circuit Breaker	87	2	Hair Pin Cotter Pin
40	1	Filter Wire	88	1	Incline Motor
41	1	Hood	89	2	Extension Leg
42	1	Front Roller Bushing	90	2	Rear Roller Bracket
43	1	Lift Frame	91	2	Lock Washer
44	2	Upright Endcap	92	3	Hood Clip
45	1	Front Roller Bolt	93	4	Wire Tie
46	1	Magnet	94	2	Endcap Pad
47	1	Front Roller/Pulley	95	2	Roller Bracket Screw
48	1	Walking Belt	96	1	Lift Frame Ground Wire

Key No.	Qty.	Description
97	1	Idler Pulley
98	1	Idler Pulley Washer
99	1	Idler Pulley Nut
100	1	Transformer
101	1	TV Cable
102	2	Cable Nut
103	1	Cable Star Washer
104	2	Frame Pivot Spacer
105	1	Console TV Cable

Key No.	Qty.	Description
#	1	12" Blue Wire, 2F
#	1	4" Red Wire, M/F
#	1	8" Green Wire, F/Ring
#	1	8" Blue Wire, M/F
#	1	User's Manual

"#" indicates a non-illustrated part.  
Specifications are subject to change without notice.

# EXPLODED DRAWING A—Model No. RBTL09906.0

R1206A

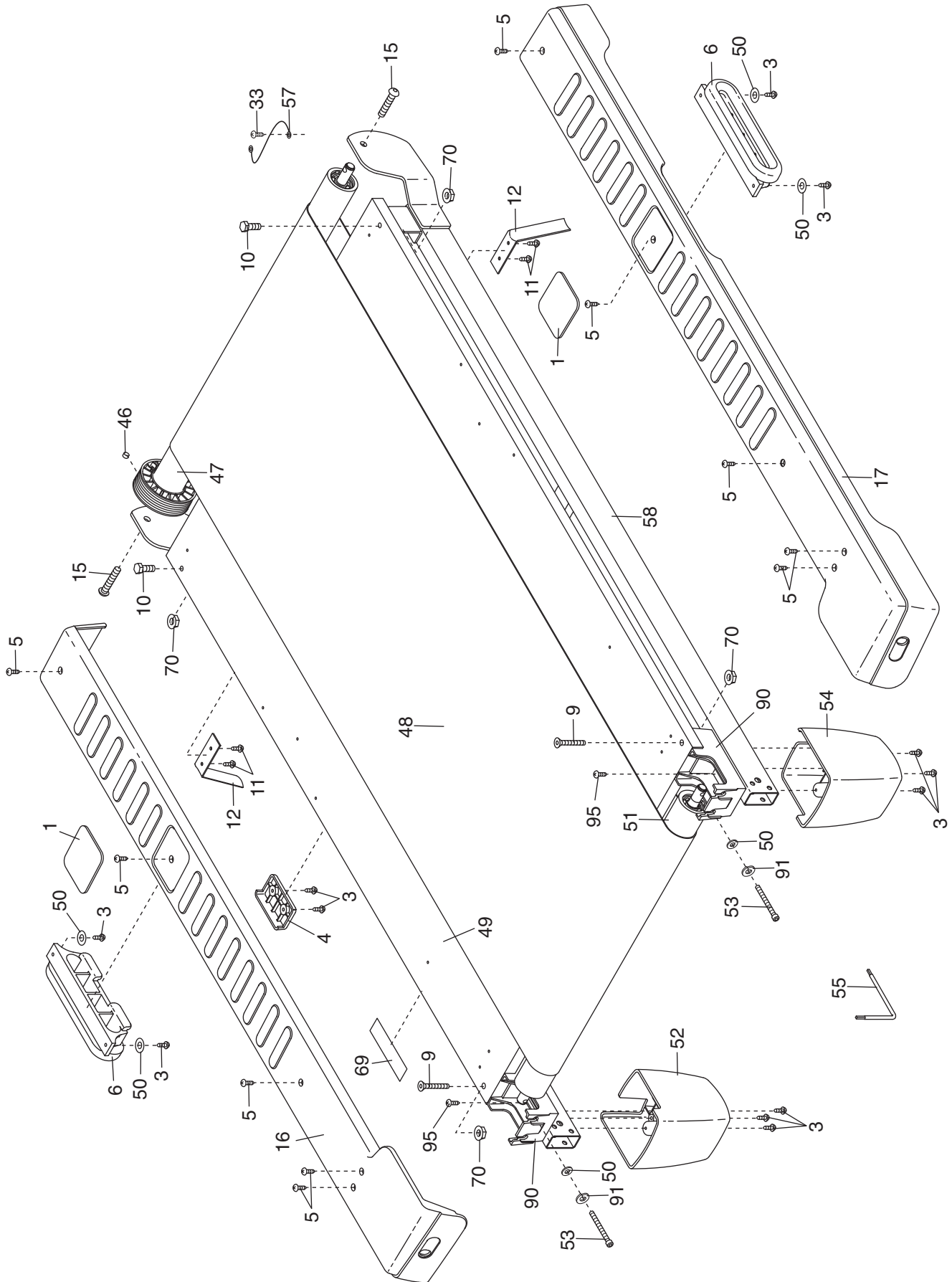

# EXPLODED DRAWING B—Model No. RBTL09906.0

R1206A

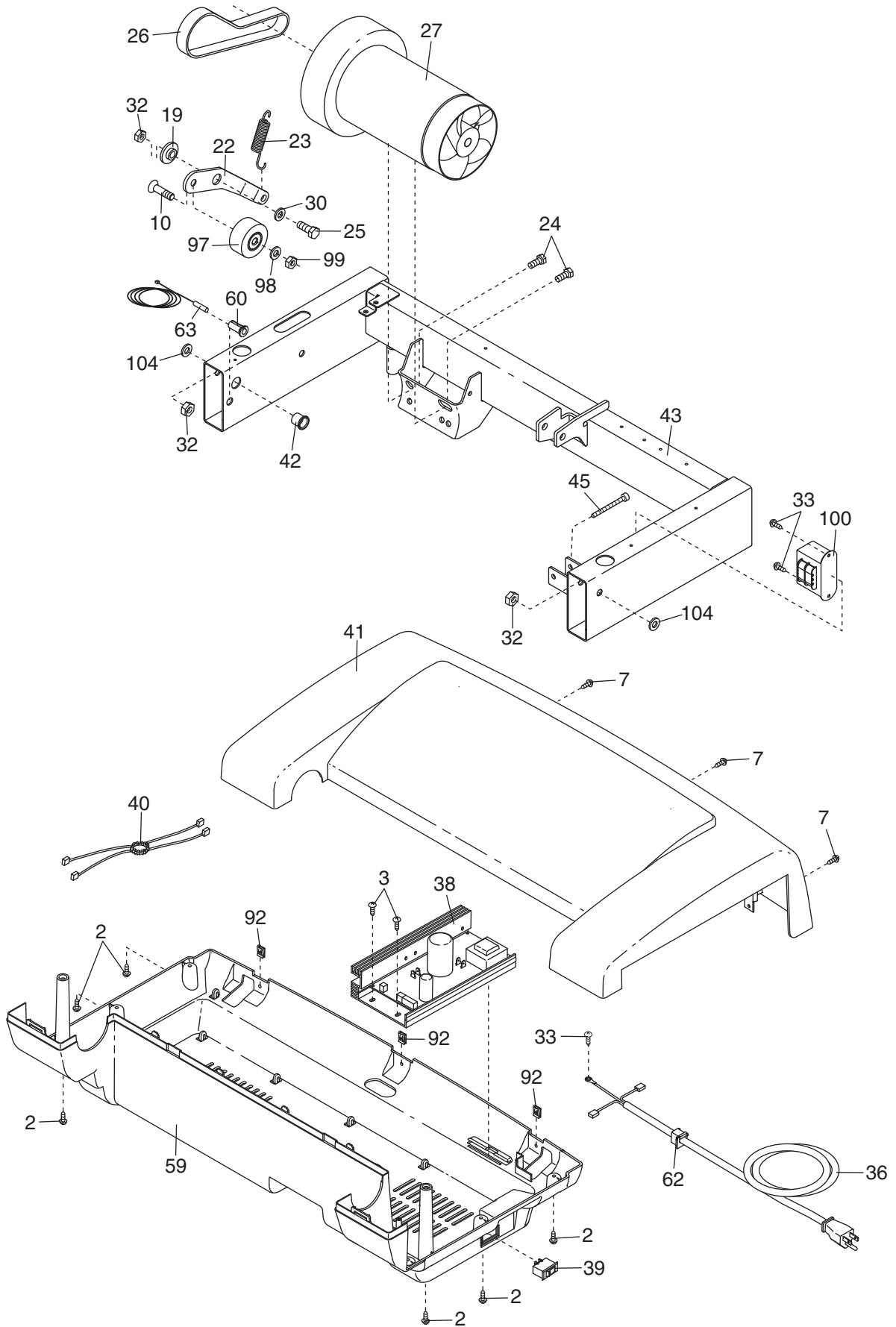

# EXPLODED DRAWING C—Model No. RBTL09906.0

R1206A

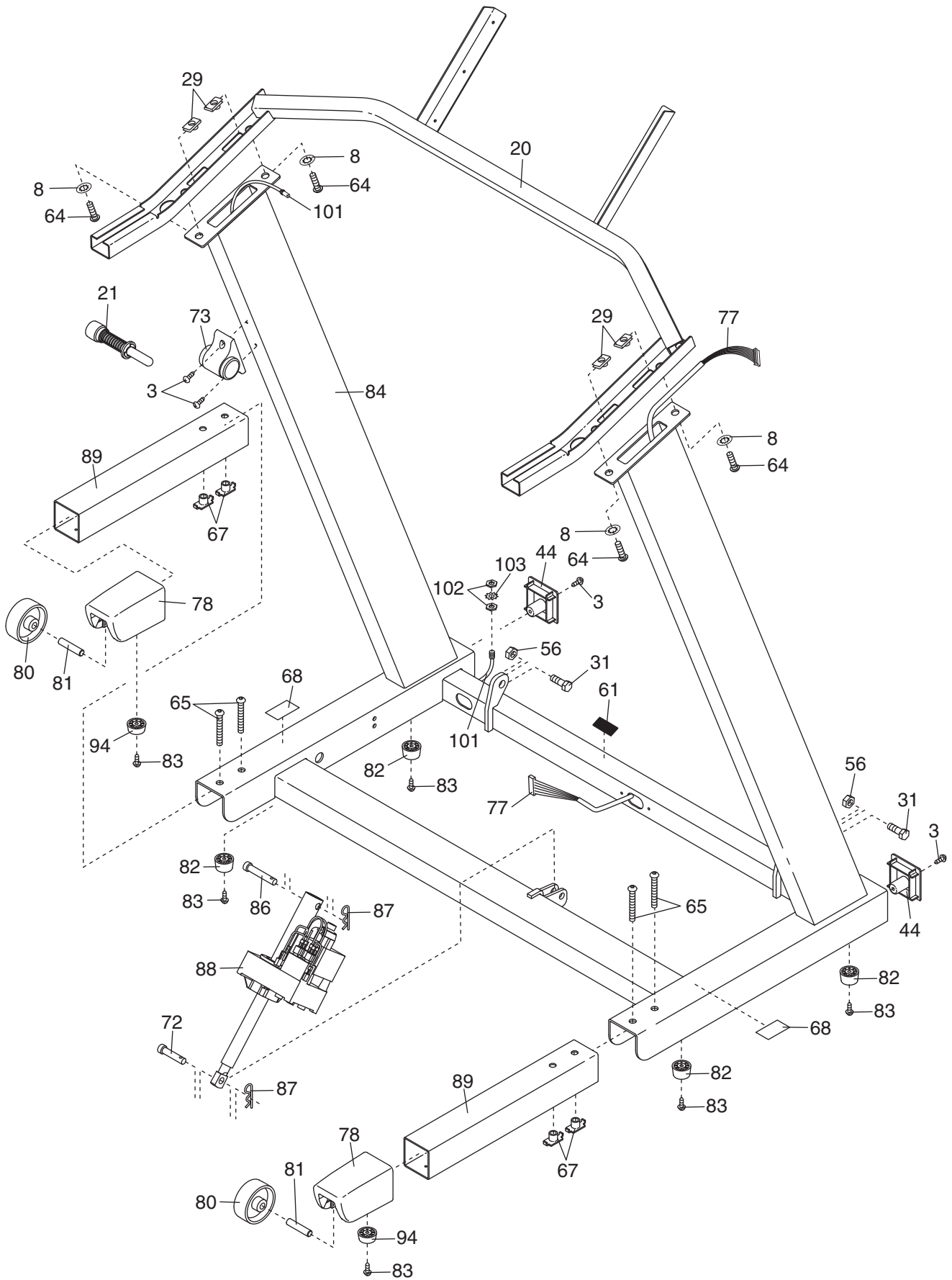

# EXPLODED DRAWING D—Model No. RBTL09906.0

R1206A

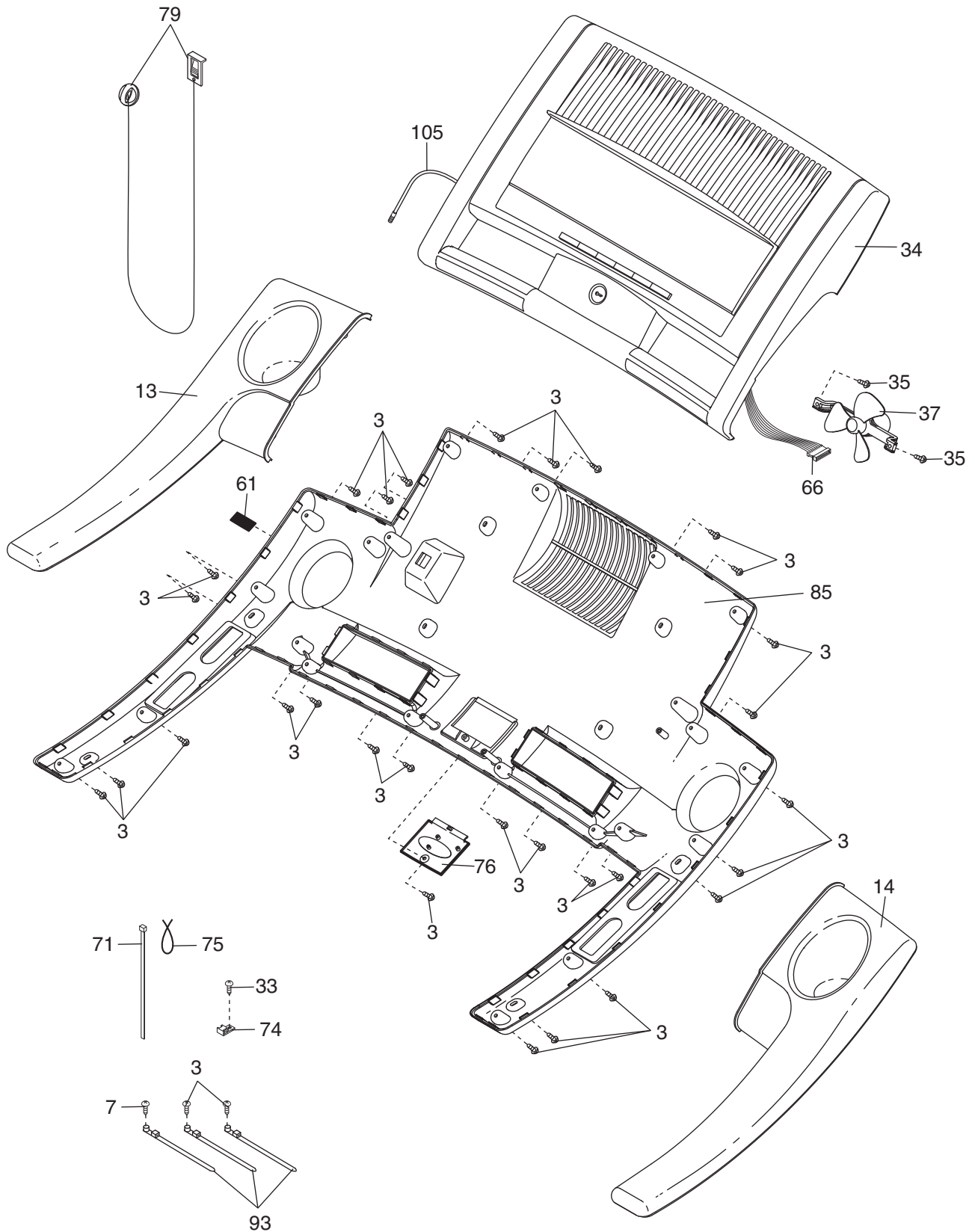

---

# ORDERING REPLACEMENT PARTS

To order replacement parts, please see the front cover of this manual. To help us assist you, be prepared to provide the following information when contacting us:

- the MODEL NUMBER of the product (RBTL09906.0)
- the NAME of the product (REEBOK VISTA 8500 treadmill)
- the SERIAL NUMBER of the product (see the front cover of this manual)
- the KEY NUMBER and DESCRIPTION of the part(s) (see the EXPLODED DRAWING and the PART LIST starting on page 30)

## LIMITED WARRANTY

ICON Health & Fitness, Inc. (ICON) warrants this product to be free from defects in workmanship and material under normal use and service conditions. The drive motor is warranted for twelve (12) years after the date of purchase. Parts and labor are warranted for ninety (90) days after the date of purchase.

This warranty extends only to the original purchaser. ICON's obligation under this warranty is limited to replacing or repairing, at ICON's option, the product through one of its authorized service centers. All repairs for which warranty claims are made must be pre-authorized by ICON. If the product is shipped to a service center, freight charges to and from the service center will be the customer's responsibility. For in-home service, the customer will be responsible for a minimal trip charge. This warranty does not extend to any product or damage to a product caused by or attributable to freight damage, abuse, misuse, improper or abnormal usage or repairs not provided by an ICON authorized service center; products used for commercial or rental purposes; or products used as store display models. No other warranty beyond that specifically set forth above is authorized by ICON.

ICON is not responsible or liable for indirect, special or consequential damages arising out of or in connection with the use or performance of the product or damages with respect to any economic loss, loss of property, loss of revenues or profits, loss of enjoyment or use, costs of removal or installation or other consequential damages of whatsoever nature. Some states do not allow the exclusion or limitation of incidental or consequential damages. Accordingly, the above limitation may not apply to you.

The warranty extended hereunder is in lieu of any and all other warranties and any implied warranties of merchantability or fitness for a particular purpose is limited in its scope and duration to the terms set forth herein. Some states do not allow limitations on how long an implied warranty lasts. Accordingly, the above limitation may not apply to you.

This warranty gives you specific legal rights. You may also have other rights which vary from state to state.

**ICON HEALTH & FITNESS, INC., 1500 S. 1000 W., LOGAN, UT 84321-9813**