

PRO·FORM[®] T 10.0

Model No. PFTL05051

Serial No. _____

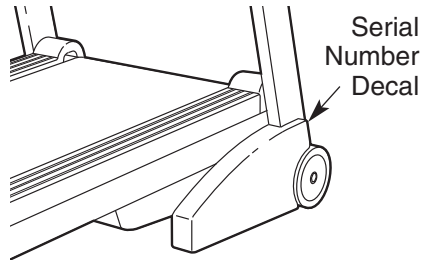

USER'S MANUAL

QUESTIONS?

As a manufacturer, we are committed to providing complete customer satisfaction. If you have questions, or find that there are missing or damaged parts, we will guarantee you complete satisfaction through direct assistance from our factory.

TO AVOID UNNECESSARY DELAYS, PLEASE CALL DIRECT TO OUR TOLL-FREE CUSTOMER HOT LINE. The trained technicians on our Customer Hot Line will provide immediate assistance, free of charge to you.

CUSTOMER HOT LINE:

1-800-999-3756

Mon.–Fri., 6 a.m.–6 p.m. MST



⚠ CAUTION

Read all precautions and instructions in this manual before using this equipment. Save this manual for future reference.

LIMITED WARRANTY

ICON Health & Fitness, Inc. ("ICON"), warrants this product to be free from defects in workmanship and material, under normal use and service conditions, for a period of ninety (90) days from the date of purchase. This warranty extends only to the original purchaser. ICON's obligation under this warranty is limited to replacing or repairing, at ICON's option, the product at one of its authorized service centers. All products for which warranty claim is made must be received by ICON at one of its authorized service centers with all freight and other transportation charges prepaid, accompanied by sufficient proof of purchase. All returns must be pre-authorized by ICON. This warranty does not extend to any product or damage to a product caused by or attributable to freight damage, abuse, misuse, improper or abnormal usage or repairs not provided by an ICON authorized service center, to products used for commercial or rental purposes, or to products used as store display models. No other warranty beyond that specifically set forth above is authorized by ICON.

ICON IS NOT RESPONSIBLE OR LIABLE FOR INDIRECT, SPECIAL OR CONSEQUENTIAL DAMAGES ARISING OUT OF OR IN CONNECTION WITH THE USE OR PERFORMANCE OF THE PRODUCT OR OTHER DAMAGES WITH RESPECT TO ANY ECONOMIC LOSS, LOSS OF PROPERTY, LOSS OF REVENUES OR PROFITS, LOSS OF ENJOYMENT OR USE, COSTS OF REMOVAL, INSTALLATION OR OTHER CONSEQUENTIAL DAMAGES OF WHATSOEVER NATURE. SOME STATES DO NOT ALLOW THE EXCLUSION OR LIMITATION OF INCIDENTAL OR CONSEQUENTIAL DAMAGES. ACCORDINGLY, THE ABOVE LIMITATION MAY NOT APPLY TO YOU.

THE WARRANTY EXTENDED HEREUNDER IS IN LIEU OF ANY AND ALL OTHER WARRANTIES AND ANY IMPLIED WARRANTIES OF MERCHANTABILITY OR FITNESS FOR A PARTICULAR PURPOSE IS LIMITED IN ITS SCOPE AND DURATION TO THE TERMS SET FORTH HEREIN. SOME STATES DO NOT ALLOW LIMITATIONS ON HOW LONG AN IMPLIED WARRANTY LASTS. ACCORDINGLY, THE ABOVE LIMITATION MAY NOT APPLY TO YOU.

This warranty gives you specific legal rights. You may also have other rights which vary from state to state.

ICON HEALTH & FITNESS, INC., 1500 S. 1000 W., LOGAN UT 84321-9813

PRO-FORM[®] T 10.0

TABLE OF CONTENTS

LIMITED WARRANTY	2
IMPORTANT PRECAUTIONS	4
BEFORE YOU BEGIN	5
ASSEMBLY	6
HOW TO USE THE PULSE SENSOR	8
OPERATION AND ADJUSTMENT	10
HOW TO USE THE MANUAL MODE	12
HOW TO USE PROGRAMS A, B, C, AND D	14
HOW TO USE THE FAT BURN AND AEROBIC PROGRAMS	16
HOW TO USE THE FITNESS TEST PROGRAM	17
TROUBLE-SHOOTING	19
CONDITIONING GUIDELINES	21
ORDERING REPLACEMENT PARTS	Back Cover

Note: An EXPLODED DRAWING and a PART LIST are attached to the center of this manual. Save the EXPLODED DRAWING and PART LIST for future reference.

⚠ WARNING: Before beginning this or any exercise program, consult your physician. This is especially important for persons over the age of 35 or persons with pre-existing health problems. Read all instructions before using. ICON assumes no responsibility for personal injury or property damage sustained by or through the use of this product.

IMPORTANT PRECAUTIONS

⚠ WARNING: To reduce the risk of burns, fire, electric shock or injury to persons, read the following important precautions and information before operating the treadmill.

1. It is the responsibility of the owner to ensure that all users of this treadmill are adequately informed of all warnings and precautions.
2. Use the treadmill only as described in this manual.
3. Place the treadmill on a level surface, with 8 feet of clearance behind it. Do not place the treadmill on a surface that blocks any air openings. To protect the floor or carpet from damage, place a mat under the treadmill.
4. Keep the treadmill indoors, away from moisture and dust. Do not put the treadmill in a garage or covered patio or near water.
5. Do not operate the treadmill where aerosol products are used or where oxygen is being administered.
6. Keep children and pets away from the treadmill at all times.
7. The treadmill should be used only by persons weighing 250 pounds or less.
8. Never allow more than one person on the treadmill at a time.
9. When connecting the power cord (see HOW TO PLUG IN THE POWER CORD on page 9), plug the power cord into a surge protector (not included) and plug the surge protector into a grounded circuit capable of carrying 15 or more amps. No other appliance should be on the same circuit.
10. Use only a UL-listed surge protector, rated at 15 amps, with a 14-gauge cord of five feet or less in length. Do not use an extension cord.
11. Keep the power cord and the surge protector away from heated surfaces.
12. Never move the walking belt while the power is turned off. Do not operate the treadmill if the power cord or plug is damaged, or if the treadmill is not working properly. (See BEFORE YOU BEGIN on page 5 if the treadmill is not working properly.)
13. Wear appropriate exercise attire when using the treadmill. Do not wear loose clothing that could become caught in the treadmill. Athletic support clothes are recommended for both men and women. *Always wear athletic shoes. Never use the treadmill with bare feet, wearing only stockings, or in sandals.*
14. Never start the treadmill while you are standing on the walking belt. Always hold the handrails while using the treadmill.
15. The treadmill is capable of high speeds. Adjust the speed in small increments to avoid sudden jumps in speed.
16. To reduce the possibility of the treadmill overheating, do not operate the treadmill continuously for longer than 1 hour.
17. The pulse sensor is not a medical device. Various factors, including the user's movement, may affect the accuracy of heart rate readings. The pulse sensor is intended only as an exercise aid in determining heart rate trends in general.
18. Never leave the treadmill unattended while it is running.
19. Always remove the key and move the on/off switch to the "off" position when the treadmill is not in use. (See the drawing on page 5 for the location of the on/off switch.)
20. Never insert any object into any opening.
21. Inspect and tighten all parts on the treadmill every three months.
22. Always unplug the power cord before performing the maintenance and adjustment procedures described in this manual. Servicing other than the procedures in this manual should be performed by an authorized service representative only.
23. This treadmill is intended for in-home use only. Do not use this treadmill in any commercial, rental, or institutional setting.

SAVE THESE INSTRUCTIONS

BEFORE YOU BEGIN

Thank you for selecting the state-of-the-art PROFORM® T10.0 treadmill. The T10.0 treadmill combines advanced technology with innovative styling to offer you an effective form of cardiovascular exercise, in the convenience and privacy of your home.

For your benefit, read this manual carefully before using the treadmill. If you have additional questions, please call our Customer Service Department toll-free at 1-800-999-3756, Monday through Friday, 6 a.m.

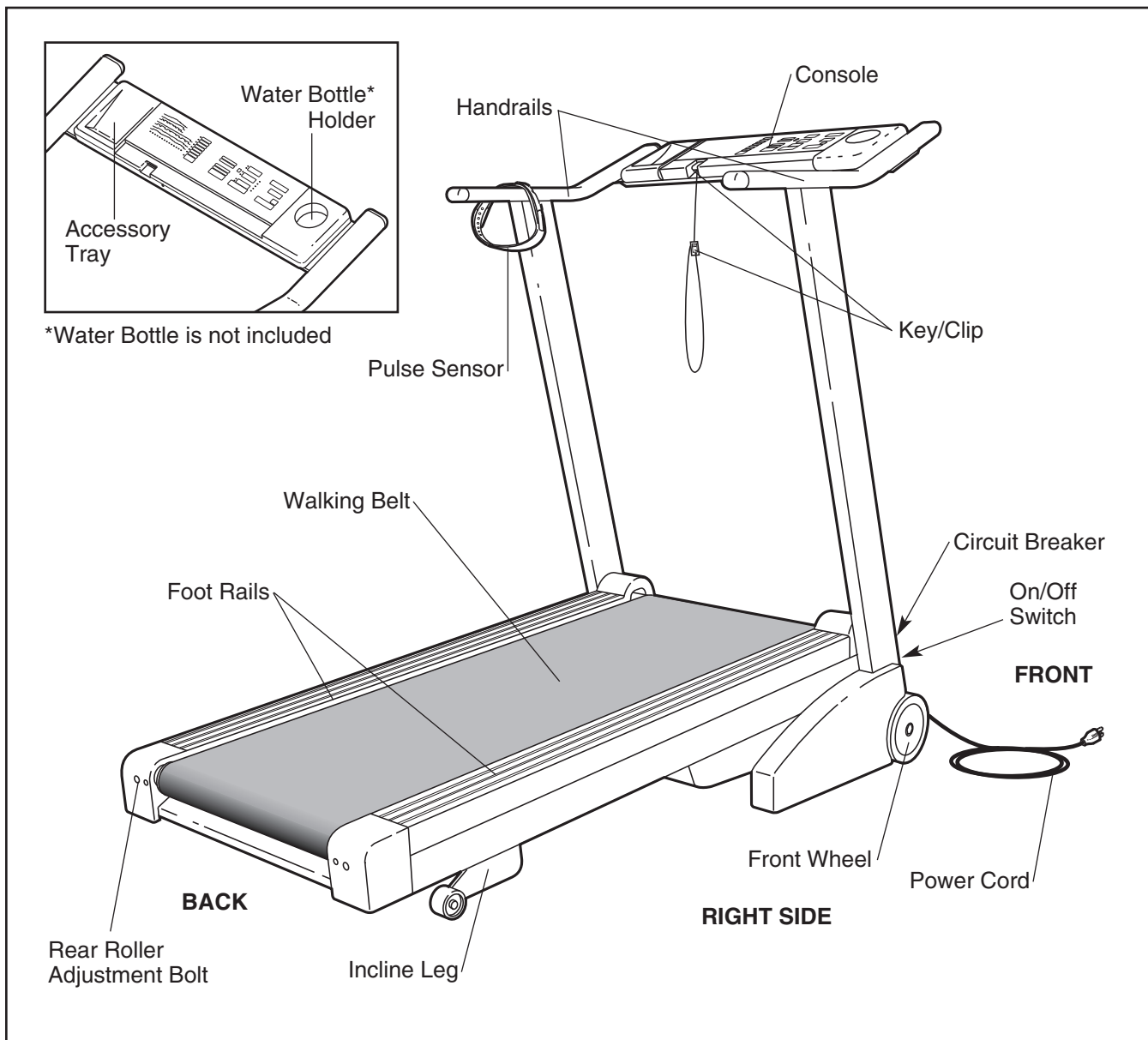

until 6 p.m. Mountain Time (excluding holidays). To help us assist you, please note the product model number and serial number before calling. The model number of the treadmill is PFTL05051. The serial number can be found on a decal attached to the treadmill (see the front cover of this manual for the location).

Before reading further, please review the drawing below and familiarize yourself with the parts that are labeled.



ASSEMBLY

Assembly requires two people. Set the treadmill in a cleared area and remove all packing materials. Do not dispose of the packing materials until assembly is completed.

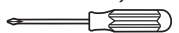
Assembly requires the following tools: The included allen wrench  , two adjustable wrenches (not included)  , and a phillips screwdriver (not included)  .

1. Firmly hold one of the Uprights (15 or 46) with both hands. Raise the Uprights about halfway.

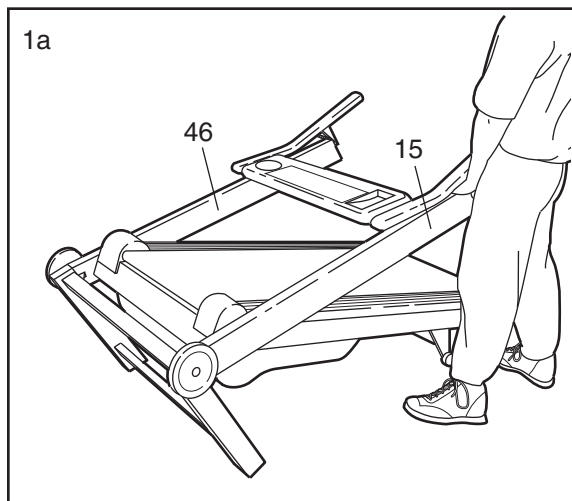

Place one foot against the base, as shown in drawing 1b. Carefully raise the Uprights (15, 46) until the base is resting on the floor.

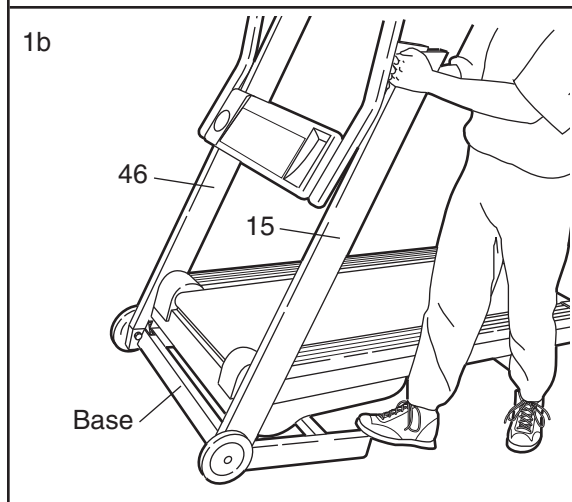

2. Pivot the Console (17) upward until it stops. Using the included allen wrench, tighten a 3/8" x 1 1/4" Bolt (45) into each Upright (15, 46).

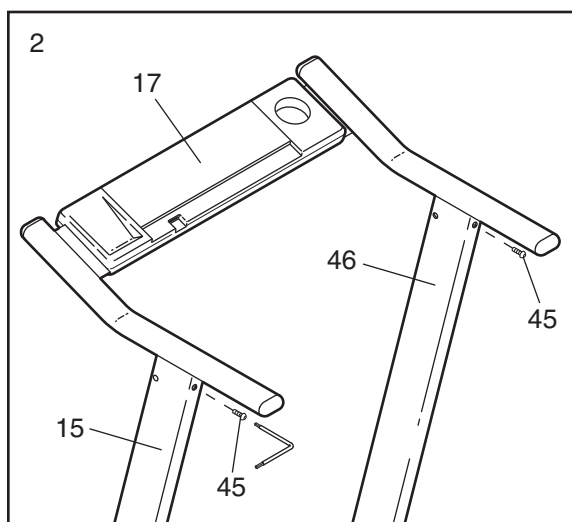

3. With the help of a second person, carefully tip the treadmill onto its right or left side.

Align the hole in the Base Shock (109) with the holes in the bracket on the Small Crossbar (108). It may be necessary to grasp the Small Crossbar and pivot it back and forth slightly. Attach the end of the Base Shock to the bracket with a 1/4" x 1" Bolt (106) and a 1/4" Nut (107). Tighten the Bolt.

With the help of a second person, carefully tip the treadmill back to the upright position.

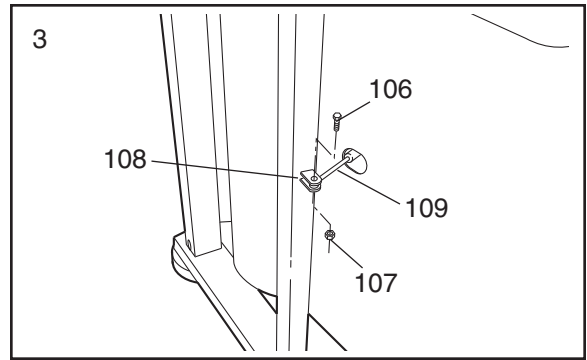

4. Attach the Right Side Cover (67) to the Right Upright (46) with three 1 3/4" Side Cover Screws (64).

Attach the Left Side Cover to the Left Upright in the same manner (not shown).

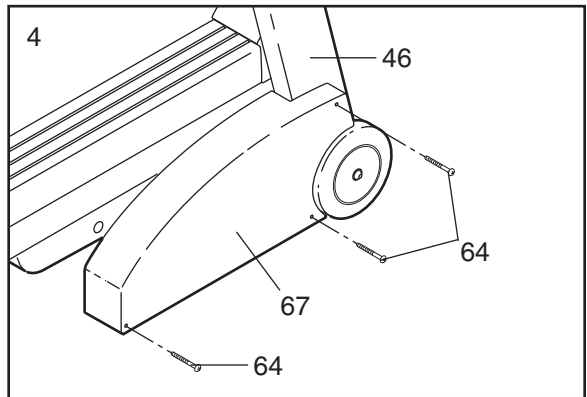

5. Remove the paper backing from the Adhesive Clip (115). Press the Adhesive Clip onto the Left Rear Endcap (88) in the indicated location. Press the Allen Wrench (114) into the Adhesive Clip.

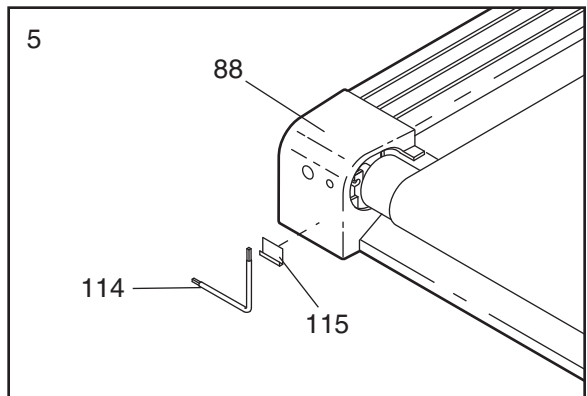

6. Attach the Pulse Sensor (4) to one of the Headbands (59 or 60). Make sure that the sensor window is pressed through the indicated hole in the Headband.

The use of the pulse sensor is explained on pages 8 and 9.

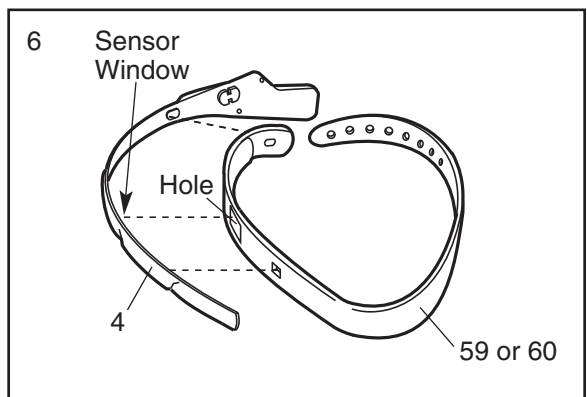

Make sure that all parts are properly tightened before you use the treadmill. **Important: Place a mat beneath the treadmill to protect the floor or carpet.**

HOW TO USE THE PULSE SENSOR

The treadmill features a state-of-the-art cordless pulse sensor, specially designed for greater accuracy, comfort, and durability. **Please read the following instructions before using the pulse sensor.**

HOW TO INSTALL BATTERIES

The pulse sensor requires **two “AAA” batteries**. Alkaline batteries are recommended. To install batteries, first slide off the battery cover as shown below.

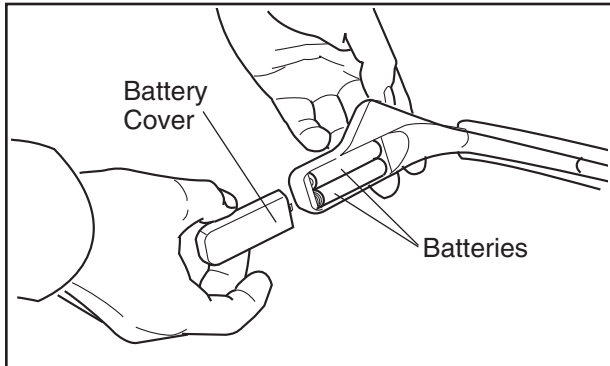

Note the markings inside the battery compartment showing which direction batteries must be turned. Insert two “AAA” batteries into the battery compartment. Replace the battery cover.

HOW TO ADJUST THE HEADBAND

For the pulse sensor to function properly, the headband must fit snugly around your head, without being uncomfortable. To adjust the headband, insert the adjustment tab through the appropriate hole in the headband.

Note: Each time you exercise, the headband may expand slightly during the first few minutes of use. It may be necessary to readjust the headband periodically.

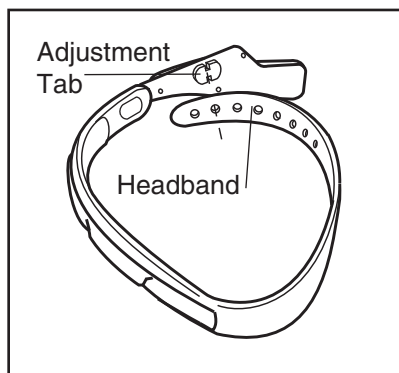

HOW TO PUT ON THE PULSE SENSOR

Rub your forehead briefly to stimulate circulation. Put on the headband as shown at the top of this page. Make sure that the sensor window is centered on your

forehead, and that there is no hair between the sensor window and your forehead.

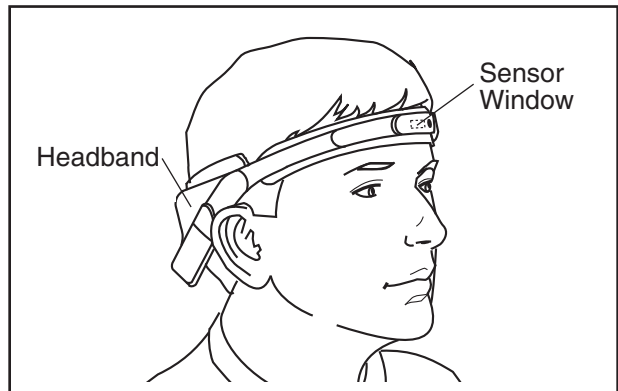

PROPER ORIENTATION OF THE PULSE SENSOR

The transmitter on the pulse sensor is angled downward, as shown below. For the pulse sensor to function properly, the transmitter must be pointed within 30° of the center of the console (the shaded area in the drawing). If you turn your head too far away from the console, the signal from the pulse sensor will not be received.

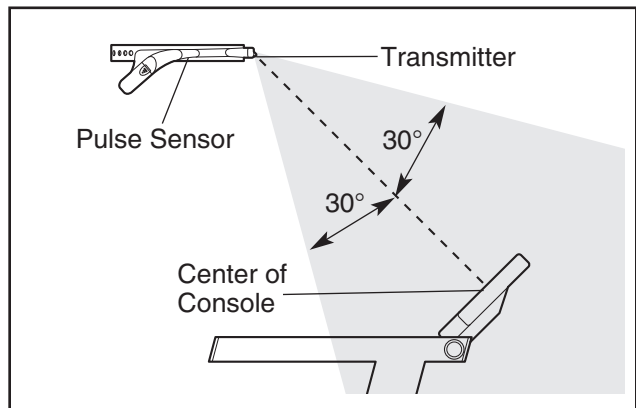

GUIDELINES FOR OBTAINING ACCURATE PULSE READINGS

The instructions on page 13 explain how the pulse sensor is used with the console (see PULSE DISPLAY). For the best results, remember the following important guidelines:

1. Before putting on the headband, rub your forehead for a moment to stimulate circulation.
2. Make sure that the headband fits snugly around your head, without being uncomfortable. If the headband is too loose or too tight, your pulse may not be detected.

3. The headband must be worn with the sensor window centered on your forehead (see HOW TO PUT ON THE PULSE SENSOR on page 8). The small button next to the sensor window must be depressed. Make sure that there is no hair in front of the pulse sensor or between the sensor window and your forehead. Make-up applied to the forehead may also interfere with pulse readings.

Note: If the pulse sensor does not detect your pulse when the sensor window is centered on your forehead, try positioning the sensor window above your right or left eyebrow. Depending on the shape of your forehead, your pulse may be detected more easily from a slightly different position.

4. Avoid turning your head more than 30° away from the console, or the console may not pick up the signal from the pulse sensor.
5. The sensor window should be cleaned weekly when the treadmill is used regularly. Moisten a cotton swab with water, and carefully wipe the sensor window.
6. Because your pulse constantly changes, the pulse sensor will sample and average your pulse every few seconds. When you first put on the pulse sensor, it may take up to ten seconds before an accurate pulse is shown.
7. If the pulse sensor does not function properly, check the batteries (see HOW TO INSTALL BATTERIES on page 8).

HOW TO SOLVE COMMON PULSE PROBLEMS

1. If you are wearing the pulse sensor and the NO PULSE DETECTED indicator lights:

See guidelines 2, 3, 4, 5, 6, and 7 on page 8 and this page.

2. If the pulse shown in the PULSE display seems excessively high or low:

See guideline 6 on this page.

3. If the error code “E5” appears in the PULSE display:

See guidelines 2, 3, 4, 5, 6, and 7 on page 8 and this page.

4. If the letters “PLS” appear in the PULSE display:

See guidelines 2, 3, 4, 5, 6, and 7 on page 8 and this page.

HOW TO CLEAN THE PULSE SENSOR AND HEADBAND

To clean the pulse sensor, first remove the headband. Wipe the pulse sensor clean with a damp cloth. **Never immerse the pulse sensor in water.**

To clean the headband, hand wash it in mild detergent, gently wring it out, and allow it to air dry.

OPERATION AND ADJUSTMENT

THE PERFORMANT LUBE™ WALKING BELT

Your treadmill features a walking belt coated with PERFORMANT LUBE™, a high-performance lubricant. **IMPORTANT: Never apply silicone spray or other substances to the walking belt or the walking platform. They will deteriorate the walking belt and cause excessive wear.**

HOW TO PLUG IN THE POWER CORD

⚠ DANGER: Improper connection of the equipment-grounding conductor can result in an increased risk of electric shock. Check with a qualified electrician or serviceman if you are in doubt as to whether the product is properly grounded. Do not modify the plug provided with the product—if it will not fit the outlet, have a proper outlet installed by a qualified electrician.

Your treadmill, like any other type of sophisticated electronic equipment, can be seriously damaged by sudden voltage changes in your home's power. Voltage surges, spikes, and noise interference can result from weather conditions or from other appliances being turned on or off.

To decrease the possibility of your treadmill being damaged, always use a surge protector (not included) with your treadmill.

Surge protectors are sold at most hardware stores and department stores. Use only a UL-listed surge protector, rated at 15 amps, with a 14-gauge cord of five feet or less in length.

This product must be grounded. If it should malfunction or break down, grounding provides a path of least resistance for electric current to reduce the risk

of electric shock. This product is equipped with a cord having an equipment-grounding conductor and a grounding plug. **Plug the power cord into a surge protector, and plug the surge protector into an appropriate outlet that is properly installed and grounded in accordance with all local codes and ordinances.**

This product is for use on a nominal 120-volt circuit, and has a grounding plug that looks like the plug illustrated in drawing 1 below. A temporary adapter that looks like the adapter illustrated in drawing 2 may be used to connect the surge protector to a 2-pole receptacle as shown in drawing 2 if a properly grounded outlet is not available.

The temporary adapter should be used only until a properly grounded outlet (drawing 1) can be installed by a qualified electrician.

The green-colored rigid ear, lug, or the like extending from the adapter must be connected to a permanent ground such as a properly grounded outlet box cover. Whenever the adapter is used it must be held in place by a metal screw. **Some 2-pole receptacle outlet box covers are not grounded. Contact a qualified electrician to determine if the outlet box cover is grounded before using an adapter.**

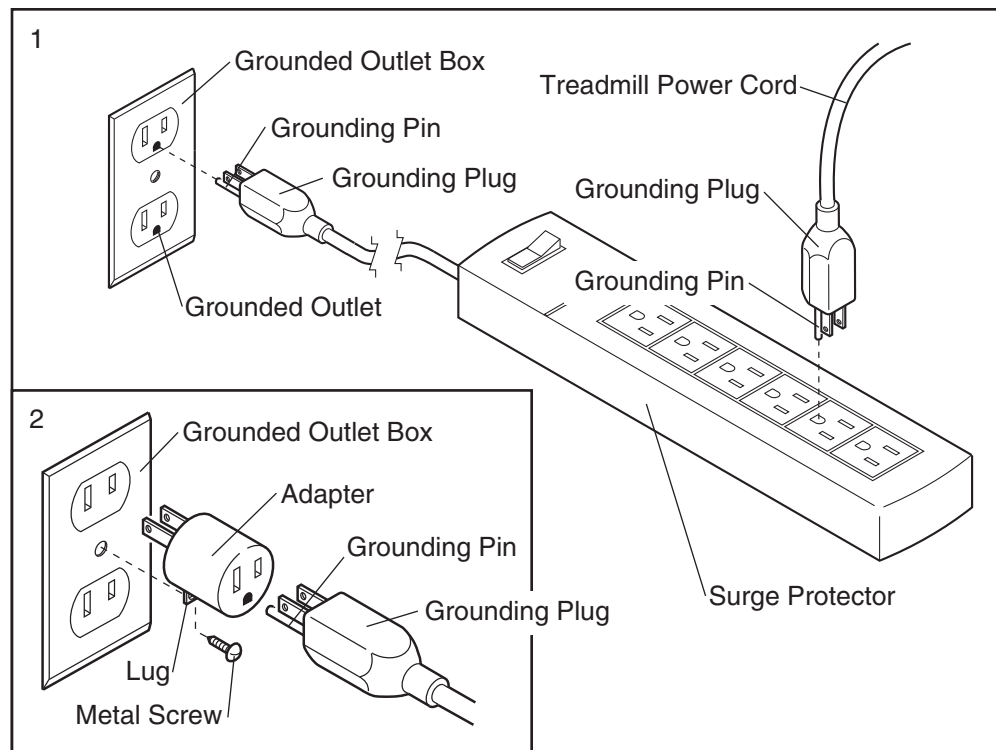
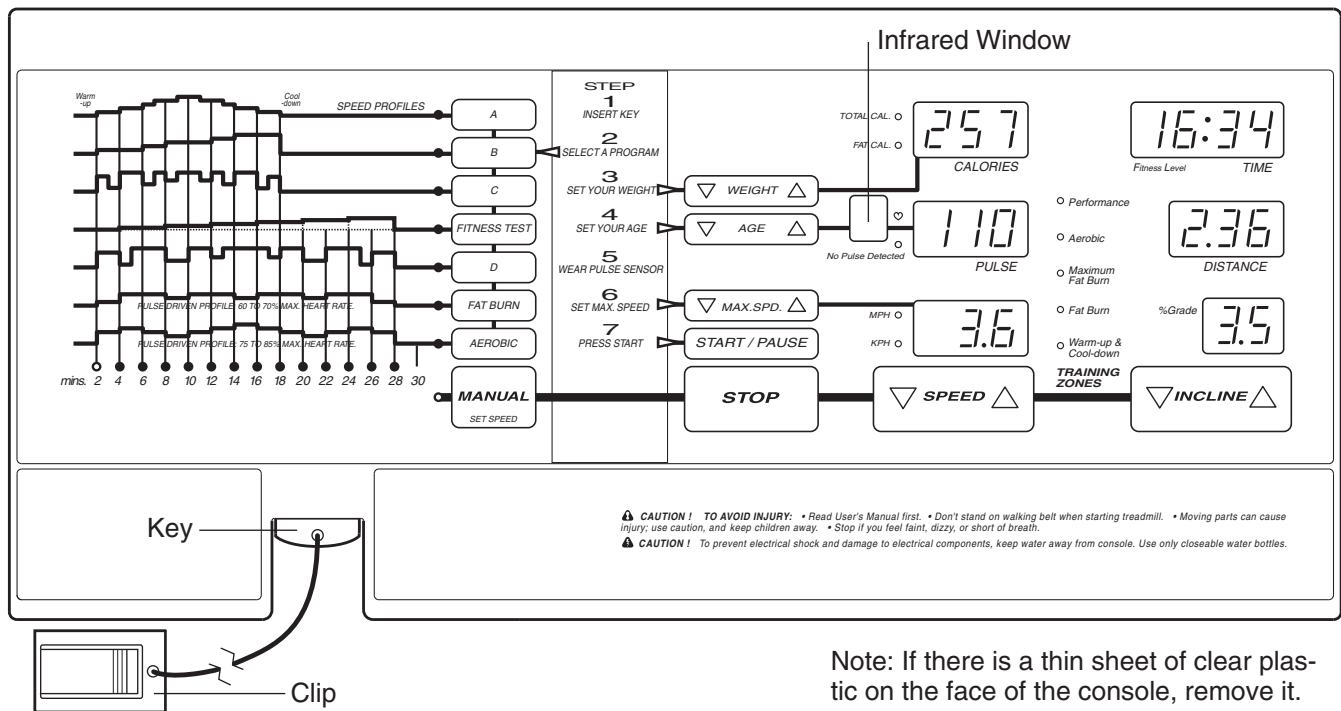

DIAGRAM OF THE CONSOLE



Note: If there is a thin sheet of clear plastic on the face of the console, remove it.

CAUTION: Before operating the console, read the following precautions.

- Do not stand on the walking belt when turning on the power or starting the walking belt.
- Always wear the clip (see the drawing above) while operating the treadmill. If the key is pulled from the console, the walking belt will stop.
- The treadmill is capable of high speeds. Adjust the speed in small increments.
- The pulse sensor is not a medical device. Various factors, including the user's movement, may affect the accuracy of pulse readings. The pulse sensor is intended only as an exercise aid in determining pulse trends in general.
- If you have heart problems, or if you are over 60 years of age and have been inactive, *do not use the FAT BURN program or the AEROBIC program.* If you are taking medication regularly, consult your physician to find whether the medication will affect your exercise heart rate.
- To reduce the risk of electric shock, keep the console dry, avoid spilling liquids on the console, and use only a sealed water bottle.

FEATURES OF THE CONSOLE

The treadmill console offers an impressive array of features designed to make your workouts more effective and enjoyable. When the console is in the manual mode, the speed and incline of the treadmill can be changed with a touch of a button. As you exercise, six displays will provide continuous exercise feedback. Seven preset programs are also offered. Programs A, B, C, and D automatically control the speed of the treadmill as they guide you through effective workouts; the special FAT BURN program provides intensive fat-burning workouts; the AEROBIC program helps you to achieve maximum cardiovascular benefits; and the unique FITNESS TEST program measures your relative fitness level.

To use the manual mode, follow the steps on pages 12 through 14. To use program A, B, C or D, see pages 14 and 15. To use the FAT BURN or AEROBIC program, see pages 16 and 17. To use the FITNESS TEST program, see pages 17 and 18. Note: The console can display speed and distance in either miles or kilometers (see SPEED DISPLAY on page 13). For simplicity, all instructions refer to miles.

Before beginning, make sure that the on/off switch located near the power cord is in the "on" position. Plug in the power cord (see page 10). Note: If the key is in the console when the power cord is plugged in, the letters "PO" will flash in the SPEED display. If this occurs, remove the key.



HOW TO USE THE MANUAL MODE

1 Insert the key fully into the console.

Stand on the foot rails and insert the key. Various displays and indicators will light. Find the clip attached to the key, and slide it onto the waistband of your clothing.

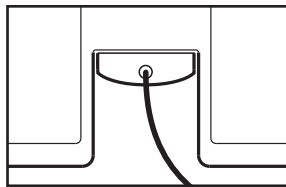

2 Select the MANUAL mode.

When the key is inserted, the manual mode will automatically be selected. The indicator beside the MANUAL button will light. Note: If a preset program has been selected, press the MANUAL button to select the manual mode.

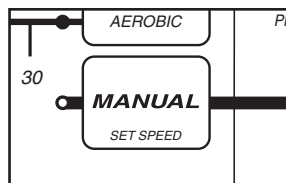

3 Enter your weight, if desired.

Although it is not necessary to enter your weight and age to use the manual mode, the CALORIES display will be more accurate if your weight and age are entered. To enter your weight:

- Press the WEIGHT increase or decrease button. The letters “LbS” will flash in the CALORIES display. Press one of the WEIGHT buttons again. The current weight setting will then be shown. Press the WEIGHT buttons again to enter your weight. Each time one of the buttons is pressed, the weight setting will change by 1 pound. If one of the buttons is held down, the weight setting will change in increments of 5 pounds. After you have entered your weight, your weight will be shown in the CALORIES display for three seconds.

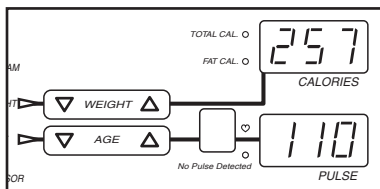

4 Enter your age, if desired.

To enter your age:

- Press the AGE increase or decrease button. The letters “AGE” will flash in the PULSE display. Press one of the AGE buttons again. The current age setting will then be shown. Press the AGE

buttons again to enter your age. Each time one of the buttons is pressed, the age setting will change by 1 year. If one of the buttons is held down, the age setting will change in increments of 5 years. After you have entered your age, your age will be shown in the PULSE display for three seconds.

Note: Once you have entered your weight and age, the numbers will be saved in the console’s memory, even if the power cord is unplugged.

5 Put on the pulse sensor, if desired.

For the PULSE display to show your pulse, the pulse sensor must be worn. To put on the pulse sensor, see HOW TO USE THE PULSE SENSOR on page 8.

6 Press the SPEED increase button to start the walking belt.

The speed of the walking belt is controlled with the SPEED increase and decrease buttons.

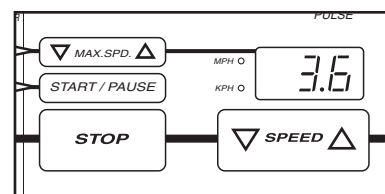

Each time one of the buttons is pressed, the speed will change by 0.1 mile per hour (mph). The buttons can be held down to change the speed more quickly. The speed range is 0.5 mph to 10 mph.

Press the SPEED increase button until the walking belt begins to move at slow speed. Hold the handrails and carefully begin walking. Change the speed of the walking belt as desired by pressing the SPEED buttons. Note: The walking belt can also be started by pressing the START/PAUSE button. The walking belt will begin to move at 0.5 mph. The speed can then be adjusted with the SPEED buttons.

To stop the walking belt, press the START/PAUSE button. All displays will pause and the TIME display will begin to flash. To restart the walking belt, press the SPEED buttons or the START/PAUSE button as described above. Note: The walking belt can also be stopped by pressing the STOP button. To restart the walking belt, press the SPEED buttons or the START/PAUSE button as described above.

Note: When the SPEED buttons are pressed, the SPEED display will show the selected speed setting for seven seconds. The display will then show the actual speed of the walking belt.

7 Change the incline of the treadmill, if desired.

The incline of the treadmill is controlled with the INCLINE increase and decrease buttons. Each time one of the buttons is pressed, the incline will change by 0.5%.

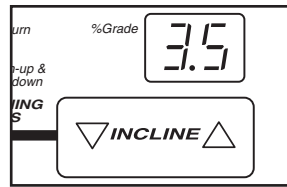

The buttons can be held down to change the incline more quickly. The incline setting is shown in the INCLINE (% Grade) display. The incline range is 1.5% to 10%. Note: After the INCLINE buttons are pressed, it may take a few seconds for the treadmill to reach the selected incline setting.

8 Follow your progress with the five displays and the TRAINING ZONE monitor.

• CALORIES display

This display shows both the *total calories* and the number of *fat calories* that you have burned. (See BURNING FAT on page 21).

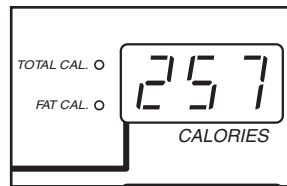

Every seven seconds, the display will change from one number to the other. The indicators beside the display will light to show which number is currently shown.

Note: This display also shows the current weight setting when the walking belt is stopped and the WEIGHT buttons are pressed.

• PULSE display

For this display to operate, the pulse sensor must be worn (see HOW TO USE THE PULSE SENSOR on page 8). After a few seconds, the heart-shaped indicator beside the PULSE display will flash each time your heart beats, the NO PULSE DETECTED indicator will darken, and your pulse will be shown. Note: Because your pulse constantly changes, the pulse sensor will sample your pulse every few seconds. *It may take up to ten seconds before an accurate pulse is shown.* If your pulse is not shown, see GUIDELINES FOR OBTAINING ACCURATE PULSE READINGS on pages 8 and 9.

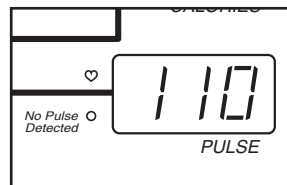

Note: This display also shows the current age setting when the walking belt is stopped and the AGE buttons are pressed.

• SPEED display

This display shows the current speed of the walking belt. When the SPEED buttons are pressed, the display will show the selected speed setting for seven seconds.

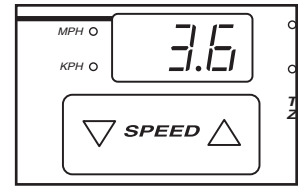

Note: The speed can be displayed in either miles per hour (mph) or kilometers per hour (kph). The indicators beside the SPEED display will light to show which unit of measurement is selected. To change the unit of measurement, hold down the STOP button while inserting the key into the console. An "E" (for English system—miles) or "M" (for Metric system—kilometers) will appear in the SPEED display. Press the SPEED increase button to change the unit of measurement. Remove and then reinsert the key.

• TIME display

This display shows the total time that the walking belt has been moving.

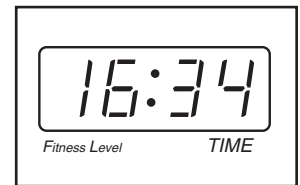

Note: When any program except the FITNESS TEST program is selected, the TIME display will show the time remaining in the program.

• DISTANCE display

This display shows the distance that you have walked or run.



Note: If the MPH indicator beside the SPEED display is lit, the distance will be displayed in miles. If the KPH indicator is lit, the distance will be displayed in kilometers.

• Training Zone Monitor

This monitor measures the approximate intensity of your exercise. The monitor's five indicators are described below:

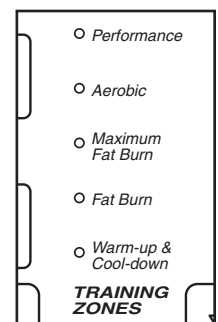

• WARM UP & COOL DOWN

Each workout should begin with a warm-up period and end with a cool-down period. (See WORKOUT GUIDELINES on pages 21 and 22.) The WARM-UP & COOL-DOWN indicator will light when your workout intensity is ideal for warming up or cooling down.

HOW TO USE PROGRAMS A, B, C, AND D

- **FAT BURN** and **MAXIMUM FAT BURN**—To burn fat effectively, you must exercise at a relatively low intensity level for a sustained period of time. (See **BURNING FAT** on page 21.) If you are exercising at the proper intensity level for burning fat, the **FAT BURN** or **MAXIMUM FAT BURN** indicator will light.
- **AEROBIC**—If your goal is to strengthen your cardiovascular system, your exercise must be “aerobic.” (See **AEROBIC EXERCISE** on page 21.) If you are exercising at the proper intensity level for aerobic exercise, the **AEROBIC** indicator will light.
- **PERFORMANCE**—If your goal is high performance athletic conditioning, you will need to exercise at a high intensity level. If you are exercising at the proper intensity level, the **PERFORMANCE** indicator will light.

9 When you are finished exercising, stop the walking belt and remove the key.

Step onto the foot rails, stop the walking belt, and remove the key from the console. Store the key in a secure place. In addition, move the on/off switch to the “off” position. (See the drawing near the bottom of page 11.)

Programs A, B, C, and D automatically control the speed of the walking belt as they guide you through effective workouts. Programs A, B, and C are 20-minute programs; program D is a 30-minute program. The speed profiles on the left side of the console show how the speed will change during each program. During program A, for example, the speed will gradually increase during the first 10 minutes, and then gradually decrease during the last 10 minutes. Each program begins with a 2-minute warm-up period, and ends with a 2-minute cool-down period.

To use program A, B, C, or D, follow the steps below.

1 Make sure that the key is fully inserted into the console.

Stand on the foot rails and insert the key. Various displays and indicators will light. Find the clip attached to the key, and slide it onto the waistband of your clothing.

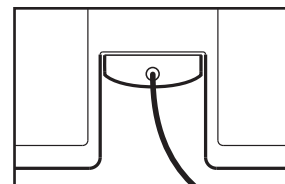

2 Select program A, B, C, or D.

Press the program button labeled A, B, C, or D. An indicator will light next to the button you press. Note: If the walking belt is moving, it will slow to a stop.

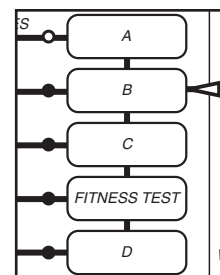

3 Enter your weight, if desired.

When program A, B, C, or D is selected, the letters “LbS” will flash in the **CALORIES** display for seven seconds, and the current weight setting will then be shown. Although it is not necessary to enter your weight and age to use one of these programs, the **CALORIES** display will be more accurate if your weight and age are entered. If you want to enter your weight, see step 3 on page 12.

4 Enter your age, if desired.

After you have completed step 3, the letters “AGE” will flash in the **PULSE** display for seven seconds, and the current age setting will then be shown. If you want to enter your age, see step 4 on page 12.

5 Put on the pulse sensor, if desired.

For the PULSE display to show your pulse, the pulse sensor must be worn. To put on the pulse sensor, see HOW TO USE THE PULSE SENSOR on page 8.

6 Set a maximum speed for the program.

After you have completed step 4, a number will appear in the SPEED display and flash for seven seconds.

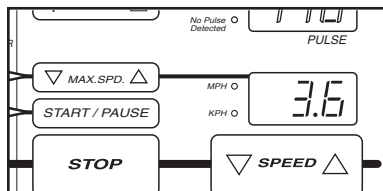

This number shows the *maximum speed* that the walking belt will move during the program. The maximum speed setting can be from 3.0 mph up to 8.5 mph. If you want to change the maximum speed setting, press the MAX. SPD. increase or decrease button. Note: The maximum speed setting will change by 0.3 mph each time one of the MAX. SPD. buttons is pressed, until it reaches 4.5 mph; the maximum speed setting will then change by 0.5 mph each time one of the buttons is pressed.

If the maximum speed setting is between 3.0 mph and 5.0 mph, the walking belt will move at 1.5 mph during the first 2 minutes and the last 2 minutes of the program (the warm-up and cool-down periods). The *speed range* during the rest of the program will be 1.5 mph. For example, if the maximum speed setting is 5.0 mph, the *speed range* will be 3.5 mph to 5.0 mph (a difference of 1.5 mph).

If the maximum speed setting is between 5.5 mph and 8.5 mph, the walking belt will move at 3.0 mph during the first 2 minutes and the last 2 minutes of the program. The *speed range* during the rest of the program will be 2.0 mph.

7 Press the START/PAUSE button to start the program.

When the START/PAUSE button is pressed, the TIME display will begin counting down from 20 minutes (or 30 minutes if program D is selected). After a moment, the walking belt will begin to move. Hold the handrails and carefully begin walking.

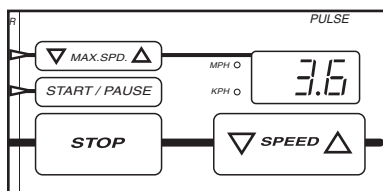

The indicators below the speed profiles will show the progress of the program.

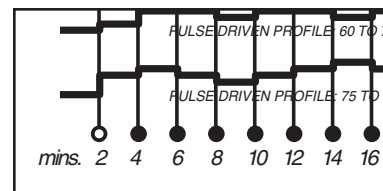

During the first 2 minutes of the program, the indicator above the number 2 will light. After 2 minutes, the indicators above the numbers 2 and 4 will light. After 4 minutes, the indicators above the numbers 4 and 6 will light, and so on. The speed of the walking belt will change periodically during the program as shown by the speed profiles. The program will continue in this manner until the time shown in the TIME display reaches zero. The walking belt will then slow to a stop and the program will be completed.

Note: The SPEED buttons will not function while program A, B, C, or D is selected. If the program is too easy or too challenging, press the MAX. SPD. buttons to set a new maximum speed. The new maximum speed setting will be shown in the SPEED display for 3 seconds. To stop the program temporarily, press the START/PAUSE button. The TIME display will begin to flash. To restart the program, press the START/PAUSE button again. The program will resume and the walking belt will return to the latest speed setting. To terminate the program before the program is completed, press the STOP button.

8 Change the incline of the treadmill, if desired.

When program A, B, C, or D is selected, the incline of the treadmill can be changed with the INCLINE buttons. See step 7 on page 13.

9 Follow your progress with the five displays and the TRAINING ZONE monitor.

See TRAINING ZONE MONITOR on pages 13 and 14.

10 When you are finished exercising, stop the walking belt and remove the key.

Step onto the foot rails, stop the walking belt, and remove the key from the console. Store the key in a secure place. In addition, move the on/off switch to the "off" position. (See the drawing near the bottom of page 11.)

HOW TO USE THE FAT BURN AND AEROBIC PROGRAMS

The FAT BURN and AEROBIC programs automatically control the speed and incline of the treadmill to keep your pulse within a predetermined range during your workouts. Both programs are 30-minute programs. The speed profiles on the left side of the console show how your pulse will change during each program. Each program begins with a warm-up period, and ends with a cool-down period.

To use one of these programs, follow the steps below.

1 Make sure that the key is fully inserted into the console.

Stand on the foot rails and insert the key. Various displays and indicators will light. Find the clip attached to the key, and slide it onto the waistband of your clothing.

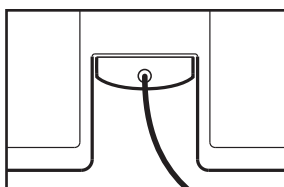

2 Select the FAT BURN or AEROBIC program.

Press the FAT BURN or AEROBIC button. An indicator will light next to the button you press. Note: If the walking belt is moving, it will slow to a stop.

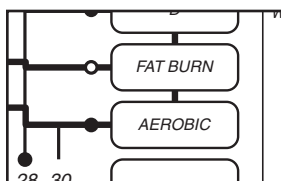

3 Enter your weight.

When the FAT BURN or AEROBIC program is selected, the letters "LbS" will flash in the CALORIES display. You must enter your weight and age before either of these programs can be started. To enter your weight, see step 3 on page 12. If you have already entered your weight, you must press one of the WEIGHT buttons to verify the weight setting.

4 Enter your age.

After you have completed step 3, the letters "AGE" will flash in the PULSE display. To enter your age, see step 4 on page 12. If you have already entered your age, you must press one of the AGE buttons to verify the age setting.

5 Put on the pulse sensor.

The pulse sensor must be worn when the FAT BURN or AEROBIC program is used. To put on the pulse

sensor, see HOW TO USE THE PULSE SENSOR on page 8. Note: The FAT BURN and AEROBIC programs can be started without your pulse being detected; however, the programs will automatically stop if your pulse is not detected 2 minutes after the programs are started.

6 Press the START/PAUSE button to start the program.

When the START/PAUSE button is pressed, the TIME display will begin counting down from 30 minutes. After a moment, the walking belt will begin to move. Hold the handrails and carefully begin walking.

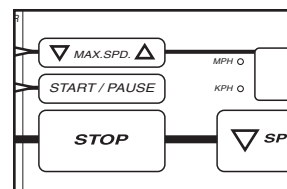

The indicators below the speed profiles will show the progress of the program.

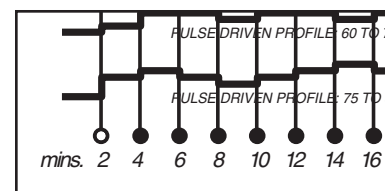

During the first 2 minutes of the program, the indicator above the number 2 will light. After 2 minutes, the indicators above the numbers 2 and 4 will light. After 4 minutes, the indicators above the numbers 4 and 6 will light, and so on. The speed and incline of the treadmill will change periodically to keep your pulse within a predetermined range, shown by the speed profiles. When the time shown in the TIME display reaches zero, the walking belt will slow to a stop and the program will be completed.

Note: If your pulse is not detected during the program, the NO PULSE DETECTED indicator will light and the letters "PLS" will flash in the PULSE display.

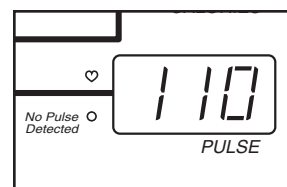

(See GUIDELINES FOR OBTAINING ACCURATE PULSE READINGS on pages 8 and 9.) If your pulse is not detected at the end of any 2-minute period during the program (after 2 minutes, after 4 minutes, after 6 minutes, etc.), the program will automatically stop.

Note: Minor adjustments can be made to the speed or incline of the treadmill during the program by pressing the SPEED or INCLINE buttons. However, if you increase the speed, the incline will automatically decrease; if you decrease the speed, the incline will automatically increase. If you increase the incline, the speed will automatically decrease; if you

decrease the incline, the speed will automatically increase. The console will always attempt to keep your pulse near a predetermined setting. When the incline reaches the highest setting, the speed cannot be decreased any further. When the incline reaches the lowest setting, the speed cannot be increased any further.

Note: To stop the program temporarily, press the START/PAUSE button. The TIME display will begin to flash. To restart the program, press the START/PAUSE button again. The program will resume and the walking belt will return to the latest speed setting. To terminate the program before the program is completed, press the STOP button.

7 Follow your progress with the five displays and the TRAINING ZONE monitor.

See TRAINING ZONE MONITOR on pages 13 and 14.

8 When you are finished exercising, stop the walking belt and remove the key.

Step onto the foot rails, stop the walking belt, and remove the key from the console. Store the key in a secure place. In addition, move the on/off switch to the "off" position. (See the drawing near the bottom of page 11.)

HOW TO USE THE FITNESS TEST PROGRAM

The FITNESS TEST program is designed to measure your relative fitness level. For the best results, the FITNESS TEST should be taken at a time when your energy level is high. The FITNESS TEST should not be taken if you have already exercised during the day.

The FITNESS TEST program consists of seven 4-minute periods, and is followed by a 2-minute cool-down period. The speed and/or incline of the treadmill will automatically increase at the beginning of each 4-minute period.

To use the FITNESS TEST program, follow the steps below.

1 Make sure that the key is fully inserted into the console.

Stand on the foot rails and insert the key. Various displays and indicators will light. Find the clip attached to the key, and slide it onto the waistband of your clothing.

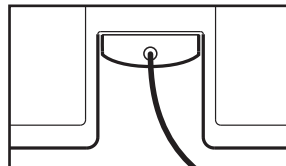

2 Select the FITNESS TEST program.

Press the FITNESS TEST button. The indicator beside the button will light. Note: If the walking belt is moving, it will slow to a stop.

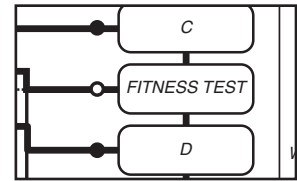

3 Enter your weight.

When the FITNESS TEST program is selected, the letters "LbS" will flash in the CALORIES display. You must enter your weight and age before this program can be started. To enter your weight, see step 3 on page 12. If you have already entered your weight, you must press one of the WEIGHT buttons to verify the weight setting.

4 Enter your age.

After you have completed step 3, the letters "AGE" will flash in the PULSE display. To enter your age, see step 4 on page 12. If you have already entered your age, you must press one of the AGE buttons to verify the age setting.

5 Put on the pulse sensor.

The pulse sensor must be worn when the FITNESS TEST program is used. To put on the pulse sensor, see HOW TO USE THE PULSE SENSOR on page 8. Note: The FITNESS TEST program can be started without your pulse being detected; however, the program will automatically stop if your pulse is not detected 4 minutes after the program is started.

6 Press the START/PAUSE button to start the program.

When the START/PAUSE button is pressed, the TIME display will begin counting up. The CALORIES display will show "L 1" (level 1), indicating that the first 4-minute period of the FITNESS TEST program has begun. The incline of the treadmill will automatically adjust to 3.0%, and the walking belt will begin to move at 1.5 mph. Hold the handrails and carefully begin walking.

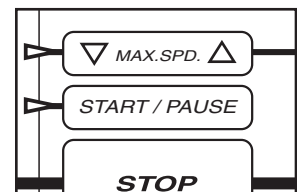

When the TIME display reaches 4 minutes, the CALORIES display will show "L 2," indicating that the second 4-minute period has begun. The incline will increase to 4%, and the speed will increase to 2.5 mph. At the beginning of each 4-minute period,

When the TIME display reaches 4 minutes, the CALORIES display will show "L 2," indicating that the second 4-minute period has begun. The incline will increase to 4%, and the speed will increase to 2.5 mph. At the beginning of each 4-minute period,

the speed and/or incline of the treadmill will automatically increase. The FITNESS TEST will continue in this manner *until your pulse reaches 70% of your maximum heart rate, and the current 4-minute period is completed. The FITNESS TEST will then be completed, regardless of how many periods remain.*

When the FITNESS TEST program is completed, the letter “C” will be shown in the CALORIES display, indicating that the cool-down period has begun. The TIME display will count down from 2 minutes. When the cool-down period is completed, the walking belt will slow to a stop, and your fitness level will be shown in the TIME display. There are ten fitness levels—fitness level 10 (FL:10) is the highest. Remember, the FITNESS TEST is intended only to indicate your relative fitness level.



Note: The SPEED and INCLINE buttons will not function while the FITNESS TEST program is selected. If your pulse is not detected during the program, the NO PULSE DETECTED indicator will light and the letters “PLS” will flash in the PULSE display. If your pulse is not detected during the last thirty seconds of any 4-minute period (after 4 minutes, after 8 minutes, etc.), the walking belt will slow to a stop, the FITNESS TEST will end, and the TIME display will show a fitness level of 0 (FL:00). (See GUIDELINES FOR OBTAINING ACCURATE PULSE READINGS on pages 8 and 9.)

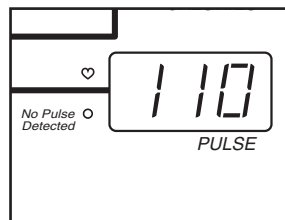

The FITNESS TEST program can be stopped at any time by pressing the STOP button. The TIME display will then show an estimated fitness level. If the STOP button is pressed a second time, the MANUAL mode will be selected.

7 When you are finished exercising, stop the walking belt and remove the key.

Step onto the foot rails, stop the walking belt, and remove the key from the console. Store the key in a secure place. In addition, move the on/off switch to the “off” position. (See the drawing near the bottom of page 11.)

HOW TO SELECT THE INFORMATION MODE

The console features an information mode that keeps track of the total time and distance accumulated on the treadmill.

To access the information mode, hold down the STOP button while inserting the key into the console.

When the information mode is selected, the symbol shown in drawing A should appear in the CALORIES display. This symbol indicates that the console is set for an infrared (cordless) pulse sensor. **IMPORTANT: If the symbol shown in drawing B appears, the cordless pulse sensor will not function. If necessary, press the WEIGHT decrease button until the symbol shown in drawing A appears.**

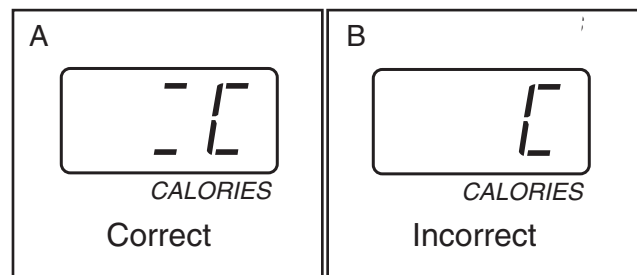

The TIME display will show the total time accumulated on the treadmill, in hours. The DISTANCE display will show the total distance, in miles (if the total distance exceeds 999, the thousands and ten thousands digits will be shown in the PULSE display). Note: The SPEED display will show an “E” (for English system—miles) or “M” (for Metric system—kilometers) (see SPEED DISPLAY on page 13).

To exit the information mode, remove the key.

TROUBLE-SHOOTING

Most treadmill problems can be solved by following the steps below. Find the symptom that applies, and follow the steps listed.

If further assistance is needed, please call our Customer Service Department toll-free at 1-800-999-3756, Monday through Friday, 6 a.m. until 6 p.m. Mountain Time (excluding holidays).

1. SYMPTOM: THE POWER DOES NOT TURN ON

- Make sure that the power cord is plugged into a surge protector, and that the surge protector is plugged into a properly grounded outlet. (See HOW TO PLUG IN THE POWER CORD on page 10.) Use only a UL-listed surge protector, rated at 15 amps, with a 14-gauge cord of five feet or less in length.
- After the power cord has been plugged in, make sure that the key is fully inserted into the console. Various indicators on the console should light. (See step 1 page 12.)
- Check the circuit breaker located on the treadmill near the power cord. If the switch protrudes as shown, the circuit breaker has tripped. To reset the circuit breaker, wait for five minutes and then press the switch back in.
- Check the on/off switch located at the front of the treadmill near the power cord. The switch must be in the “on” position.

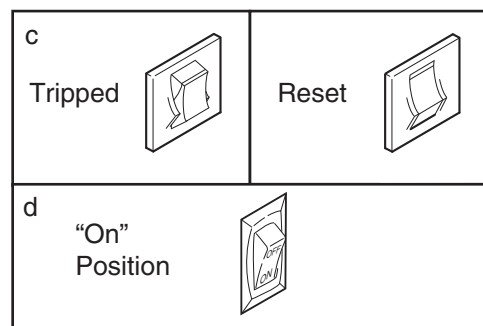

2. SYMPTOM: THE POWER TURNS OFF DURING USE

- Check the circuit breaker located on the treadmill near the power cord (see 1. c. above). If the circuit breaker has tripped, wait for five minutes and then press the switch back in.
- Make sure that the power cord is plugged in.
- Remove the key from the console, and reinsert it fully into the console. (See step 1 on page 12.)
- Check to make sure that the on/off switch is in the “on” position. (See 1. d. above.)
- If the treadmill still will not run, please call our Customer Service Department.

3. SYMPTOM: AN ERROR CODE (“E1,” “E2,” “E3,” “E4,” OR “E5”) APPEARS ON THE CONSOLE

- If error code “E1” appears in the DISTANCE/INCLINE display, a malfunction may have occurred in the incline system. Remove the key, wait for ten seconds, and then reinsert it. If the error code appears again, call our Customer Service Department. Do not operate the treadmill until the problem is corrected.
- Error code “E2” may appear in the SPEED display if the SPEED increase or START/PAUSE button is pressed and no movement of the walking belt is detected within seven seconds. Remove the key, wait for ten seconds, and then reinsert it. Make sure that you stand on the foot rails of the treadmill each time you start the walking belt. If the error code appears again, call our Customer Service Department. Do not operate the treadmill until the problem is corrected.
- Error code “E3” may appear in the SPEED display if the speed of the walking belt surges above the selected speed setting. Remove the key, wait for ten seconds, and then reinsert it. If the error code appears again, call our Customer Service Department. Do not operate the treadmill until the problem is corrected.

- d. Error code “E4” may appear in the SPEED display if the walking belt is moving at a slow speed, and there is excessive stress on the motor. Remove the key, wait for ten seconds, and then reinsert it. If you weigh over 200 pounds, it may be helpful to increase the incline of the treadmill. If the error code appears again, call our Customer Service Department. Do not operate the treadmill until the problem is corrected.
- e. Error code “E5” may appear in the PULSE display if a pulse error occurs. See HOW TO USE THE PULSE SENSOR on pages 8 and 9, and PULSE DISPLAY on page 13.

4. SYMPTOM: THE PULSE SENSOR DOES NOT FUNCTION PROPERLY

- a. See HOW TO USE THE PULSE SENSOR on pages 8 and 9, PULSE DISPLAY on page 13, and HOW TO SELECT THE INFORMATION MODE on page 18.

5. SYMPTOM: THE WALKING BELT IS OFF-CENTER OR SLIPS WHEN WALKED ON

- a. If the walking belt has shifted to the left, first remove the KEY and **UNPLUG THE POWER CORD**. Using the 3/16” end of the allen wrench, turn the left rear roller adjustment bolt clockwise 1/4 of a turn. Plug in the power cord, insert the KEY and run the treadmill for a few minutes. Repeat until the walking belt is centered.

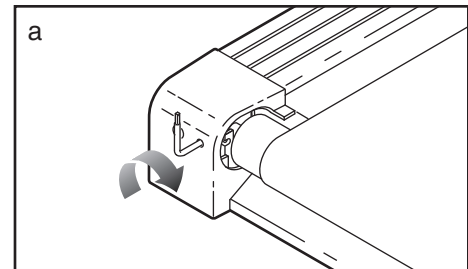

- b. If the walking belt has shifted to the right, first remove the KEY and **UNPLUG THE POWER CORD**. Using the 3/16” end of the allen wrench, turn the left rear roller adjustment bolt counter-clockwise 1/4 of a turn. Plug in the power cord, insert the KEY and run the treadmill for a few minutes. Repeat until the walking belt is centered.

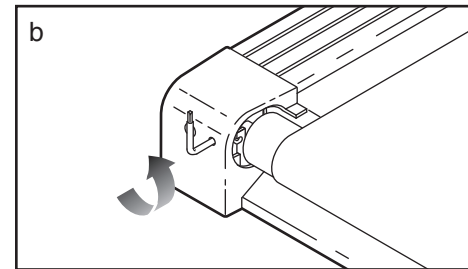

6. SYMPTOM: THE WALKING BELT SLOWS OR SLIPS WHEN WALKED ON

- a. Use only a UL-listed surge protector, rated at 15 amps, with a 14-gauge cord of five feet or less in length.

- b. If the walking belt is loose, treadmill performance may decrease and the walking belt may slip when walked on. To adjust the tension of the walking belt, remove the key and **UNPLUG THE POWER CORD**. Remove the three Endcap Screws (20) from the Right Rear Endcap (98). Slide the Endcap off the Frame (84). Using an adjustable wrench, hold the Rear Roller Adjustment Nut (89). Using the 3/16” end of allen wrench, turn the Right Rear Adjustment Bolt (112) clockwise, 1/2 of a turn. Reattach the Endcap.

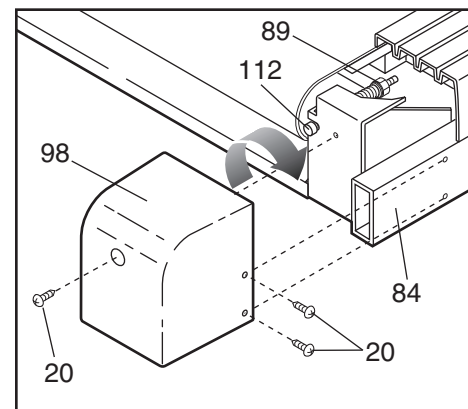

Plug in the power cord, insert the key and run the treadmill for a few minutes. Note: Make sure the walking belt is centered (see SYMPTOM 5 above). Repeat until the walking belt no longer slips.

- c. If the walking belt still slows when walked on, please call our Customer Service Department.

CONDITIONING GUIDELINES

⚠ WARNING: Before beginning this or any exercise program, consult your physician. This is especially important for individuals over the age of 35 or individuals with pre-existing health problems.

The pulse sensor is not a medical device. Various factors, including your movement, may affect the accuracy of heart rate readings. The sensor is intended only as an exercise aid in determining heart rate trends in general.

The following guidelines will help you to plan your exercise program. Remember—these are general guidelines. For more detailed information about exercise, obtain a reputable book or consult your physician.

EXERCISE INTENSITY

Whether you want to burn fat, strengthen your cardiovascular system, or increase your athletic performance, you can tailor your exercise to your specific goals. The key to achieving the desired results is to exercise with the proper intensity.

Burning Fat

To burn fat effectively, you must exercise at a relatively low intensity level for a sustained period of time. During the first few minutes of exercise, your body uses easily accessible *carbohydrate calories* for energy. Only after the first few minutes of exercise does your body begin to use stored *fat calories* for energy. If your goal is to burn fat, adjust the speed and incline of the treadmill until the FAT BURN indicator is lit. (See TRAINING ZONE MONITOR on pages 13 and 14.)

Aerobic Exercise

If your goal is to strengthen your cardiovascular system, your exercise must be “aerobic.” Aerobic exercise is activity that requires large amounts of oxygen for prolonged periods of time. This increases the demand on the heart to pump blood to the muscles, and on the lungs to oxygenate the blood. The proper intensity level for aerobic exercise can be found by using your pulse as a guide. As you exercise, your pulse should be kept at a level between 70% and 85% of your maximum possible heart rate. This is known as your training zone. You can find your training zone in the table at the top of this page. Training zones are listed according to age and physical condition.

During the first few months of your exercise program,

Age	Training Zone (Beats/Min.)	
	Unconditioned	Conditioned
20	138-167	133-162
25	136-166	132-160
30	135-164	130-158
35	134-162	129-156
40	132-161	127-155
45	131-159	125-153
50	129-156	124-150
55	127-155	122-149
60	126-153	121-147
65	125-151	119-145
70	123-150	118-144
75	122-147	117-142
80	120-146	115-140
85	118-144	114-139

keep your pulse near the low end of your training zone as you exercise. After a few months of regular exercise, your pulse can be gradually increased until it is near the middle of your training zone as you exercise. You can measure your pulse using the pulse sensor. Exercise for about four minutes, and then measure your pulse immediately. If your pulse is too high or too low, adjust the intensity of your exercise. It may also be helpful to adjust the speed and incline of the treadmill until the AEROBIC indicator is lit. (See TRAINING ZONE MONITOR on pages 13 and 14.)

Performance Training

If your goal is high performance athletic conditioning, adjust the speed and incline of the treadmill until the PERFORMANCE indicator is lit. (See TRAINING ZONE MONITOR on pages 13 and 14.)

WORKOUT GUIDELINES

Each workout should include three parts: (1) a warm-up, (2) training zone exercise, and (3) a cool-down.

Warm-up

Warming up prepares the body for exercise by increasing circulation, delivering more oxygen to the muscles and raising the body temperature. Begin each workout with 5 to 10 minutes of stretching and light exercise to warm up (see SUGGESTED STRETCHES on page 23).

Training Zone Exercise

After warming up, increase the intensity of your exercise until your pulse is in your training zone for 20 to 60 minutes. (During the first few weeks of your exercise program, do not keep your pulse in your training zone for longer than 20 minutes.) Breathe regularly and deeply as you exercise—never hold your breath.

Cool-down

Finish each workout with 5 to 10 minutes of stretching to cool down. This will increase the flexibility of your muscles and will help to prevent post-exercise problems.

Exercise Frequency

To maintain or improve your condition, complete three workouts each week, with at least one day of rest between workouts. After a few months, you may complete up to five workouts each week if desired.

Instead of waiting for a convenient time to exercise, plan a specific time. The morning hours work well for many, and the self-discipline required to rise early and exercise often carries through the day to help increase productivity in other areas. For some, exercising before dinner initiates a period of winding down from the day's activities. Whatever time you choose, be consistent and stick with it.

To maintain or improve your condition, complete three workouts each week, with at least one day of rest between workouts. After a few months of regular exercise, you may complete up to five workouts each week, if desired. Remember, the key to success is to make exercise a regular and enjoyable part of your everyday life.

WORKOUT ATTIRE

Exercise clothing should be comfortable and allow unrestricted movement. Do not wear rubberized or plastic clothing that can interfere with the evaporation of sweat from your skin. Always wear athletic shoes that are flexible and provide good protection and support.

ADDITIONAL SUGGESTIONS

Creating a more active lifestyle, in addition to establishing a regular exercise program, will help you to achieve your fitness goals.

It's easy to improve your lifestyle by making a few changes in your daily routine:

- Keep yourself moving throughout the day. Use the stairs instead of the elevator. Park a half mile away from work or get off the bus a couple of blocks before your stop and walk the remaining distance.
- Increase midday productivity, creativity and energy by replacing a heavy lunch with a light meal. Spend the extra time in physical activity such as walking.
- Substitute manually-operated devices for automatic equipment such as lawn-care machinery, power tools and snow removers.
- Stop smoking; smoking nearly doubles the risk of coronary heart disease. (Framington Heart Study)
- Reduce or eliminate alcohol consumption. Alcohol is a major cause of liver problems and other health disorders. (Office of Disease Prevention and Health Promotion)
- Reduce your intake of fat. Less than 30% of the calories you consume each day should come from fat. Excessive fat consumption has been linked to numerous causes of death, including heart disease and cancer.
- Know and keep a record of your cholesterol level, blood pressure and other health information. Keep your blood pressure below 140/90; keeping it below 125/85 is preferable.

SUGGESTED STRETCHES

The correct form for several basic stretches is shown in the drawings below. Move slowly as you stretch—never bounce.

1. Toe Touch Stretch

Stand with your knees bent slightly and slowly bend forward from your hips. Allow your back and shoulders to relax as you reach down toward your toes as far as possible. Hold for 15 counts, then relax. Repeat 3 times. Stretches: Hamstrings, back of knees and back.

2. Hamstring Stretch

Sit with one leg extended. Bring the sole of the opposite foot toward you and rest it against the inner thigh of your extended leg. Reach toward your toes as far as possible. Hold for 15 counts, then relax. Repeat 3 times for both legs. Stretches: Hamstrings, lower back and groin.

3. Calf/Achilles Stretch

With one leg in front of the other, reach forward and place your hands against a wall. Keep your back leg straight and your back foot flat on the floor. Bend your front leg, lean forward and move your hips toward the wall. Hold for 15 counts, then relax. Repeat 3 times for both legs. To cause further stretching of the achilles tendons, bend your back leg as well. Stretches: Calves, achilles tendons and ankles.

4. Quadriceps Stretch

With one hand against a wall for balance, reach back and grasp one foot with your other hand. Bring your heel as close to your buttocks as possible. Hold for 15 counts, then relax. Repeat 3 times for both legs. Stretches: Quadriceps and hip muscles.

5. Inner Thigh Stretch

Sit with the soles of your feet together and your knees outward. Pull your feet toward your groin area as far as possible. Hold for 15 counts, then relax. Repeat 3 times. Stretches: Quadriceps and hip muscles.

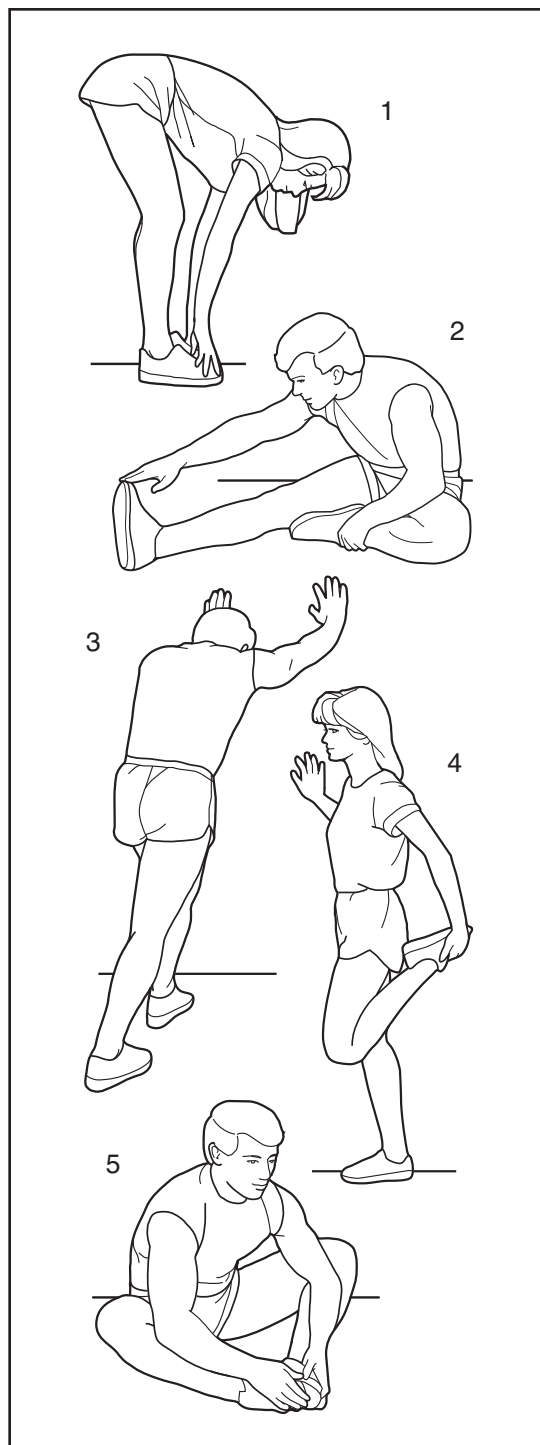

PART LIST—Model No. PFTL05051

R1296A

Key No.	Qty.	Description	Key No.	Qty.	Description
1	4	Handrail Endcap	66	2	Wheel Bolt
2	1	Handrail	67	1	Right Side Cover
3	2	Handrail Cover	68	1	Rear Roller
4	1	Pulse Sensor	69	4	Upright Foot
5	15	Console Screw/Foot Screw	70	2	Optic Switch
6	1	Upright Wire Harness	71	1	Small Star Washer
7	1	24" Cable Loom	72	1	Incline Optic Disk
8	2	Handrail Pivot Bolt	73	2	Incline Pin
9	2	Cage Nut	74	2	Incline Motor Spacer
10	1	7/32 Allen Wrench (not used)	75	2	Hair Pin Cotter
11	5	8" Wire Tie	76	1	Incline Motor
12	2	Upright Plug	77	1	Incline Rod
13	12	Small Screw	78	1	Incline Rod Bolt
14	3	Cable Tie Holder	79	4	Incline Leg Nut
15	1	Left Upright	80	1	Fuse
16	2	Foot Rail w/Fastener	81	1	Power Board w/Stand-Off
17	1	Console	82	4	Plastic Stand-Off
18	1	Key/Clip	83	1	Electronics Bracket
19	1	Roller Pulley Endcap	84	1	Frame
20	12	Endcap Screw	85	1	Walking Belt w/Fastener
21	1	Motor Belt	86	1	Walking Platform w/Fastener
22	2	Motor Bolt	87	8	Platform Screw
23	1	Pulley/Flywheel/Fan	88	1	Left Rear Endcap
24	1	Motor	89	1	Rear Roller Tension Nut
25	1	Motor Mount Bracket	90	1	Spring Sleeve
26	1	Small Shock Bolt	91	1	Roller Tension Spring
27	1	Motor Tension Nut	92	4	Edge Strip
28	1	Front Roller/Pulley	93	2	Incline Leg Bolt
29	1	Motor Tension Star Washer	94	1	Motor Controller Wire
30	1	Motor Tension Washer	95	2	Incline Leg Wheel
31	1	Motor Tension Bolt	96	2	Incline Wheel Bolt
32	1	Motor Swivel Bolt	97	1	Incline Leg
33	2	Motor Nut	98	1	Right Rear Endcap
34	1	Front Right Endcap	99	2	Large Crossbar Bolt
35	1	Speed Disk	100	1	Optic Switch Star Washer
36	2	Small Bolt	101	2	Upright Bracket Screw
37	1	Optic Switch Bracket	102	2	Upright Bracket
38*	1	Motor/Pulley/Flywheel/Fan	103	4	Crossbar Nut
39	2	Small Nut	104	2	Small Crossbar Bolt
40	2	Optic Switch Wire Harness	105	1	Large Crossbar
41	1	Optic Switch Nut	106	1	1/4" x 1" Bolt
42	1	On/Off Switch	107	1	1/4" Nut
43	1	Circuit Breaker	108	1	Small Crossbar
44	5	Adjustment Washer	109	1	Shock
45	2	3/8" x 1 1/4" Bolt	110	1	Left Side Cover
46	1	Right Upright	111	1	Crossbar Cover
47	1	Front Roller Adjust Bolt	112	1	Right Rear Adjustment Bolt
48	1	Power Cord	113	1	Left Rear Adjustment Bolt
49	1	Grommet	114	1	Allen Wrench
50	1	Belly Pan Wire Harness	115	1	Adhesive Clip
51	3	12" Cable Loom	116	2	Roller Guard
52	2	Water Bottle Holder	#	12	Fastener
53	1	Small Cover	#	1	14" White Wire, 2 Female
54	1	Belly Pan	#	1	14" White Wire, Male/Female
55	17	Belly Pan Screw	#	1	9" Black Wire, Male/Female
56	1	Belly Pan Plug	#	1	4" Black Wire, 2 Female
57	8	Isolator	#	1	14" Blue Wire, 2 Female
58	2	Belt Guide	#	1	8" Blue Wire, Male/Female
59	1	Red Headband	#	1	8" Red Wire, Male/Female
60	1	Blue Headband	#	1	8" Green Ground Wire
61	4	Upright Pivot Nut	#	1	User's Manual
62	1	Controller			
63	2	Upright Pivot Bolt			
64	6	1 3/4" Side Cover Screw			
65	2	Front Wheel			

* Includes all parts shown in the box.

These parts are not illustrated.

EXPLODED DRAWING—Model No. PFTL05051

R1296A

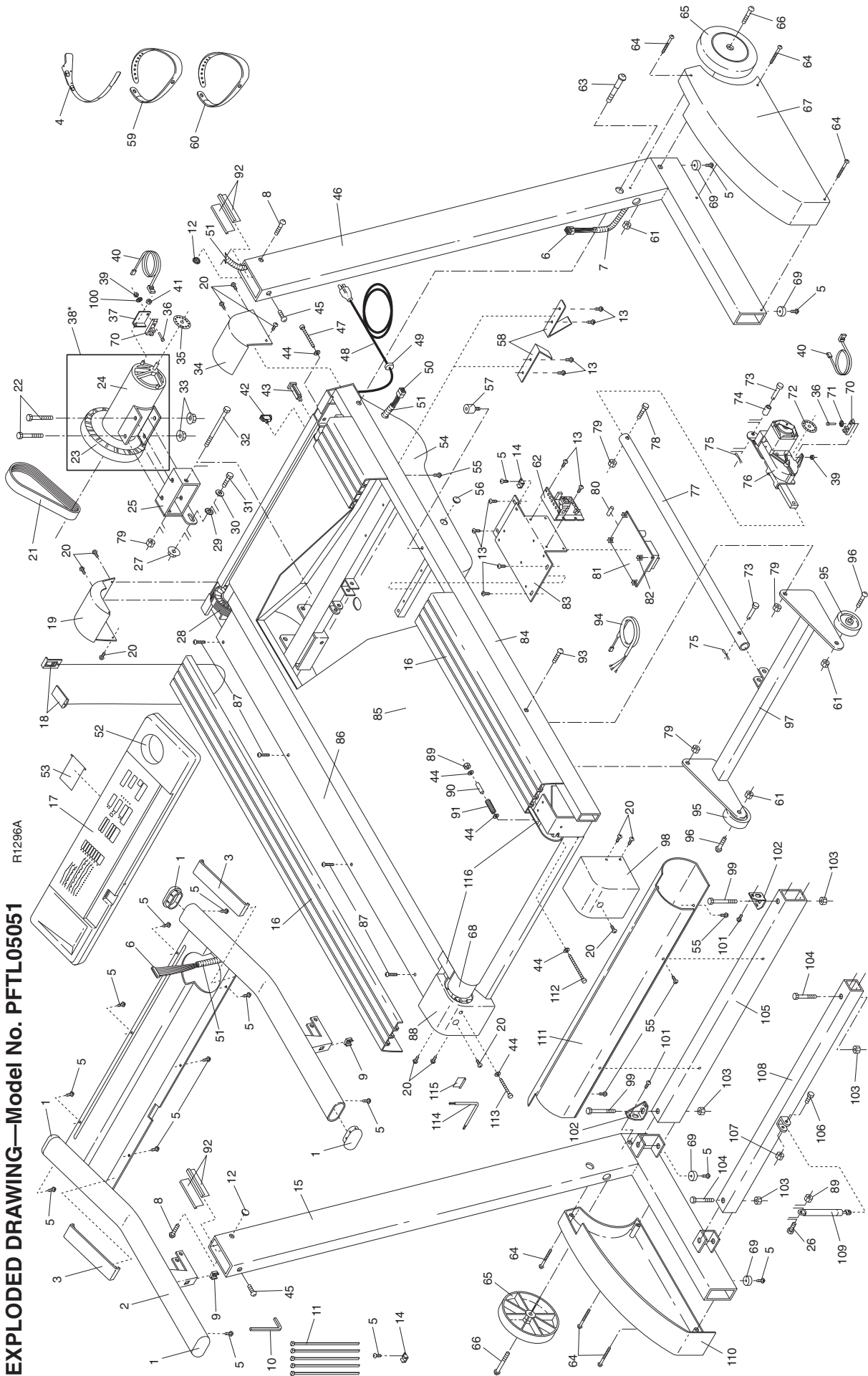

ORDERING REPLACEMENT PARTS

To order replacement parts, call our Customer Service Department toll-free at 1-800-999-3756, Monday through Friday, 6 a.m. until 6 p.m. Mountain Time (excluding holidays). When ordering parts, please be prepared to give the following information:

- The MODEL NUMBER OF THE PRODUCT (PFTL05051).
- The NAME OF THE PRODUCT (PROFORM® T10.0 treadmill).
- The SERIAL NUMBER OF THE PRODUCT (see the front cover of this manual).
- The KEY NUMBER OF THE PART(S) (see the EXPLODED DRAWING and PART LIST attached to the center of this manual).
- The DESCRIPTION OF THE PART(S) (see the EXPLODED DRAWING and PART LIST attached to the center of this manual).

If possible, place the treadmill near your telephone for easy reference when calling.