

# PRO-FORM<sup>®</sup>

## 605 CS

[www.proform.com](http://www.proform.com)

Model No. PFTL66010.0

Serial No. \_\_\_\_\_

Write the serial number in the space above for reference.

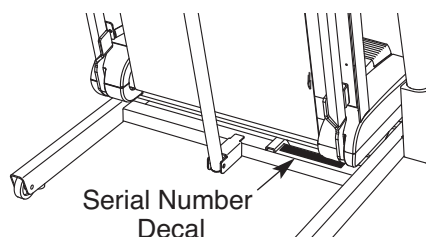

## USER'S MANUAL

### QUESTIONS?

If you have questions, or if parts are damaged or missing, **DO NOT CONTACT THE STORE**; please contact Customer Care.

**IMPORTANT:** Please register this product (see the limited warranty on the back cover of this manual) before contacting Customer Care.

CALL TOLL-FREE:

**1-888-533-1333**

Mon.–Fri. 6 a.m.–6 p.m. MT

Sat. 8 a.m.–4 p.m. MT

ON THE WEB:

[www.proformservice.com](http://www.proformservice.com)

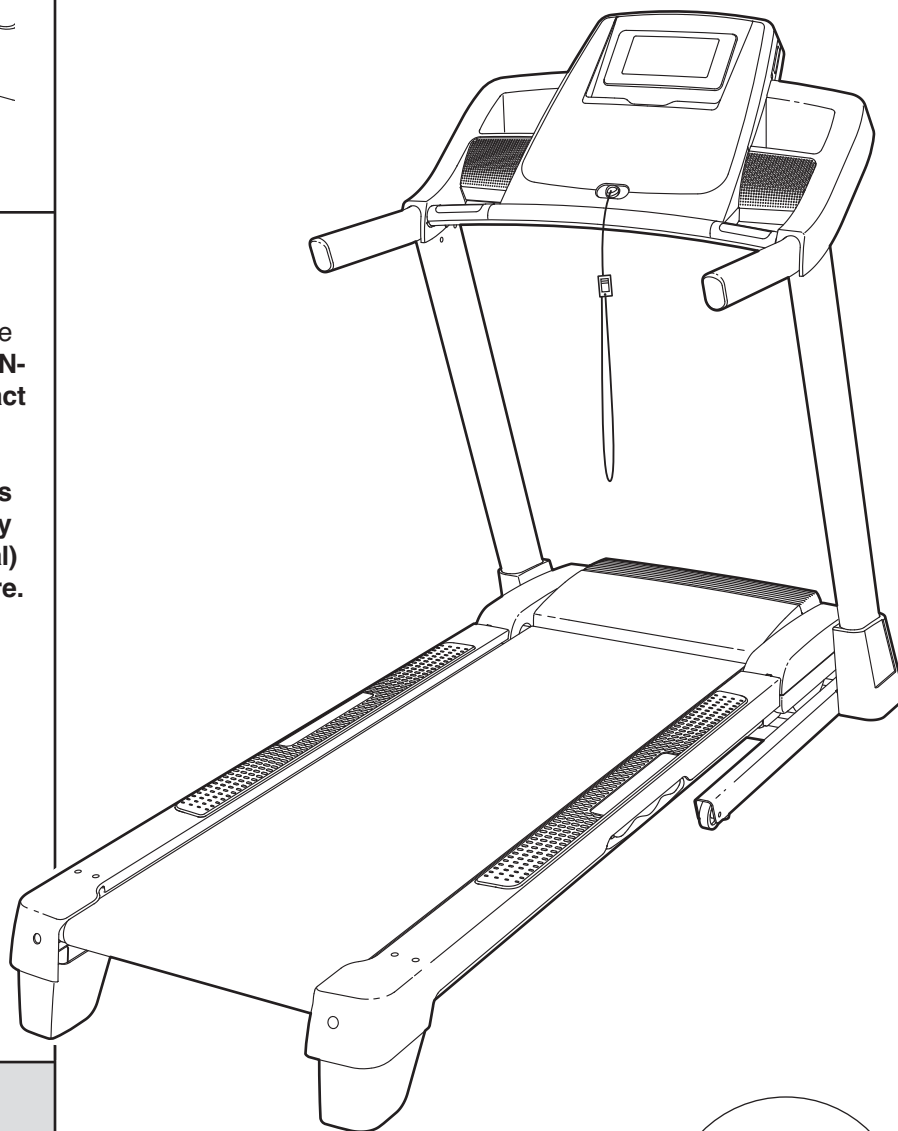

### CAUTION

Read all precautions and instructions in this manual before using this equipment. Save this manual for future reference.



# TABLE OF CONTENTS



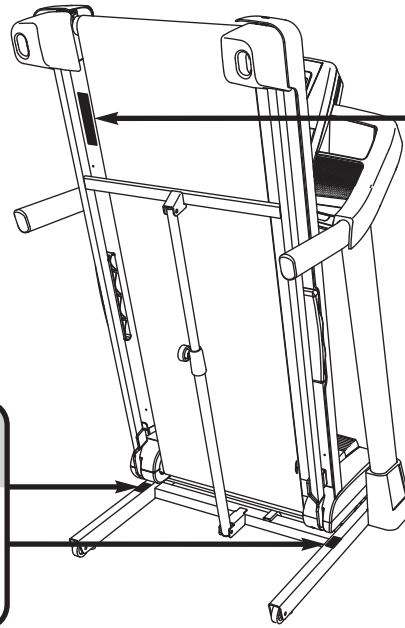

WARNING DECAL PLACEMENT .....2  
 IMPORTANT PRECAUTIONS .....3  
 BEFORE YOU BEGIN .....5  
 ASSEMBLY .....6  
 OPERATION AND ADJUSTMENT .....14  
 HOW TO FOLD AND MOVE THE TREADMILL .....21  
 TROUBLESHOOTING .....22  
 EXERCISE GUIDELINES .....25  
 PART LIST .....26  
 EXPLODED DRAWING .....28  
 ORDERING REPLACEMENT PARTS .....Back Cover  
 LIMITED WARRANTY .....Back Cover

## WARNING DECAL PLACEMENT

This drawing shows the locations of the warning decals. **If a decal is missing or illegible, call the telephone number on the front cover of this manual and request a free replacement decal. Apply the decal in the location shown.** Note: The decals may not be shown at actual size.



**▲WARNING:**  
 Protect yourself and others from risk of serious injury. Read the user's manual and :

-  •Stand only on the side rails when starting or stopping treadmill.
- Change speed in small increments.
- Hold handrails to prevent falling, and always wear the safety clip while operating treadmill.
- Stop if you feel faint, dizzy, or short of breath.
- Fully engage storage latch before treadmill is moved or stored.
- Reduce incline to its lowest level before folding treadmill into storage position.
-  •Never allow children on or around treadmill.
- Remove key when not in use.
-  •Keep clothing, fingers, and hair away from moving belt.
- Never try to adjust or fix the belt while it is moving.
-  •Always wear athletic shoes while operating treadmill.

# IMPORTANT PRECAUTIONS

**⚠ WARNING:** To reduce the risk of serious injury, read all important precautions and instructions in this manual and all warnings on your treadmill before using your treadmill. ICON assumes no responsibility for personal injury or property damage sustained by or through the use of this product.

1. Before beginning any exercise program, consult your physician. This is especially important for persons over age 35 or persons with pre-existing health problems.
2. It is the responsibility of the owner to ensure that all users of this treadmill are adequately informed of all warnings and precautions.
3. Use the treadmill only as described.
4. Place the treadmill on a level surface, with at least 8 ft. (2.4 m) of clearance behind it and 2 ft. (0.6 m) on each side. Do not place the treadmill on any surface that blocks air openings. To protect the floor or carpet from damage, place a mat under the treadmill.
5. Keep the treadmill indoors, away from moisture and dust. Do not put the treadmill in a garage or covered patio, or near water.
6. Do not operate the treadmill where aerosol products are used or where oxygen is being administered.
7. Keep children under age 12 and pets away from the treadmill at all times.
8. The treadmill should be used only by persons weighing 325 lbs. (147 kg) or less.
9. Never allow more than one person on the treadmill at a time.
10. Wear appropriate exercise clothes when using the treadmill. Do not wear loose clothes that could become caught in the treadmill. Athletic support clothes are recommended for both men and women. *Always wear athletic shoes. Never use the treadmill with bare feet, wearing only stockings, or in sandals.*
11. When connecting the power cord (see page 14), plug the power cord into a surge suppressor (not included) and plug the surge suppressor into a grounded circuit capable of carrying 15 or more amps. No other appliance should be on the same circuit. Do not use an extension cord.
12. Use only a single-outlet surge suppressor that meets all of the specifications described on page 14. To purchase a surge suppressor, see your local PROFORM dealer or call the telephone number on the front cover of this manual and order part number 146148, or see your local electronics store.
13. Failure to use a properly functioning surge suppressor could result in damage to the control system of the treadmill. If the control system is damaged, the walking belt may slow, accelerate, or stop unexpectedly, which may result in a fall and serious injury.
14. Keep the power cord and the surge suppressor away from heated surfaces.
15. Never move the walking belt while the power is turned off. Do not operate the treadmill if the power cord or plug is damaged, or if the treadmill is not working properly. (See TROUBLESHOOTING on page 22 if the treadmill is not working properly.)
16. Read, understand, and test the emergency stop procedure before using the treadmill (see HOW TO TURN ON THE POWER on page 16).
17. Never start the treadmill while you are standing on the walking belt. Always hold the handrails while using the treadmill.
18. The treadmill is capable of high speeds. Adjust the speed in small increments to avoid sudden jumps in speed.
19. The pulse sensor is not a medical device. Various factors, including the user's movement, may affect the accuracy of heart rate readings. The pulse sensor is intended only as an exercise aid in determining heart rate trends in general.

20. Never leave the treadmill unattended while it is running. Always remove the key, unplug the power cord, and switch the reset/off circuit breaker to the off position when the treadmill is not in use. (See the drawing on page 5 for the location of the circuit breaker.)
21. Do not attempt to raise, lower, or move the treadmill until it is properly assembled. (See ASSEMBLY on page 6, and HOW TO FOLD AND MOVE THE TREADMILL on page 21.) You must be able to safely lift 45 lbs. (20 kg) to raise, lower, or move the treadmill.
22. When folding or moving the treadmill, make sure that the storage latch is holding the frame securely in the storage position.
23. Never insert any object into any opening on the treadmill.
24. Inspect and properly tighten all parts of the treadmill regularly.
25. **DANGER:** Always unplug the power cord immediately after use, before cleaning the treadmill, and before performing the maintenance and adjustment procedures described in this manual. Never remove the motor hood unless instructed to do so by an authorized service representative. Servicing other than the procedures in this manual should be performed by an authorized service representative only.
26. This treadmill is intended for in-home use only. Do not use this treadmill in a commercial, rental, or institutional setting.
27. Over exercising may result in serious injury or death. If you feel faint or if you experience pain while exercising, stop immediately and cool down.

**SAVE THESE INSTRUCTIONS**

# BEFORE YOU BEGIN

Thank you for selecting the revolutionary PROFORM® 605 CS treadmill. The 605 CS treadmill offers an impressive selection of features designed to make your workouts at home more enjoyable and effective. And when you're not exercising, the unique treadmill can be folded up, requiring less than half the floor space of other treadmills.

**For your benefit, read this manual carefully before using the treadmill.** If you have questions after read-

ing this manual, please see the front cover of this manual. To help us assist you, please note the product model number and serial number before contacting us. The model number and the location of the serial number decal are shown on the front cover of this manual.

Before reading further, please review the drawing below and familiarize yourself with the labeled parts.

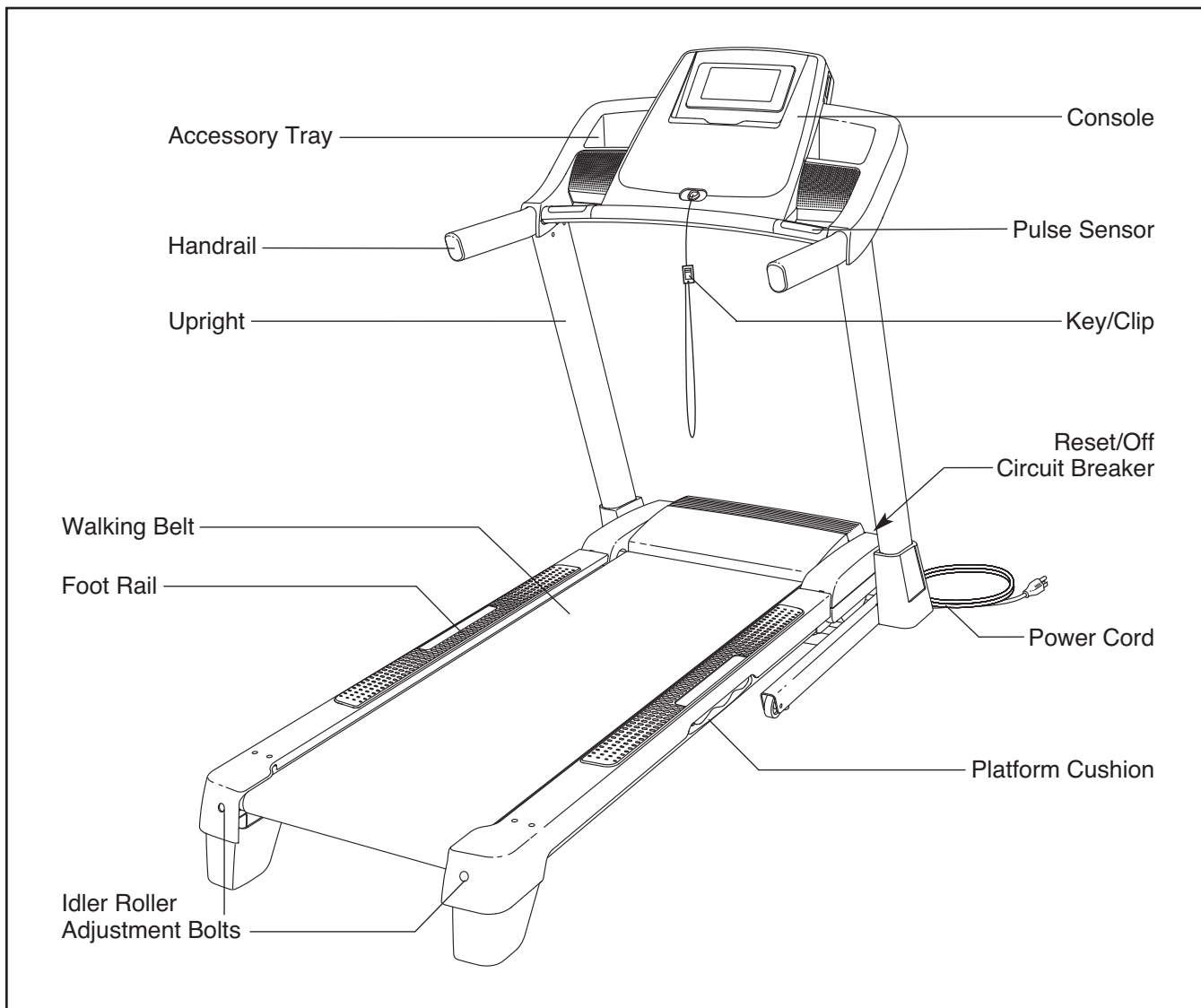

# ASSEMBLY

To hire an authorized service technician to assemble the treadmill, call 1-800-445-2480.

**Assembly requires two persons.** Set the treadmill in a cleared area and remove all packing materials. **Do not dispose of the packing materials until assembly is completed.** Note: The underside of the treadmill walking belt is coated with high-performance lubricant. During shipping, some lubricant may be transferred to the top of the walking belt or the shipping carton. This is normal and does not affect treadmill performance. If there is lubricant on top of the walking belt, simply wipe off the lubricant with a soft cloth and a mild, non-abrasive cleaner.

**Assembly requires the included hex key  and your own Phillips screwdriver , adjustable wrench , needlenose pliers , and scissors .**

Use the drawings below to identify the assembly hardware. The number in parentheses below each drawing is the key number of the part, from the PART LIST near the end of this manual. The number after the parentheses is the quantity needed for assembly. **Note: If a part is not in the hardware kit, check to see if it is preattached to one of the parts to be assembled. To avoid damaging parts, do not use power tools for assembly. Extra hardware may be included.**

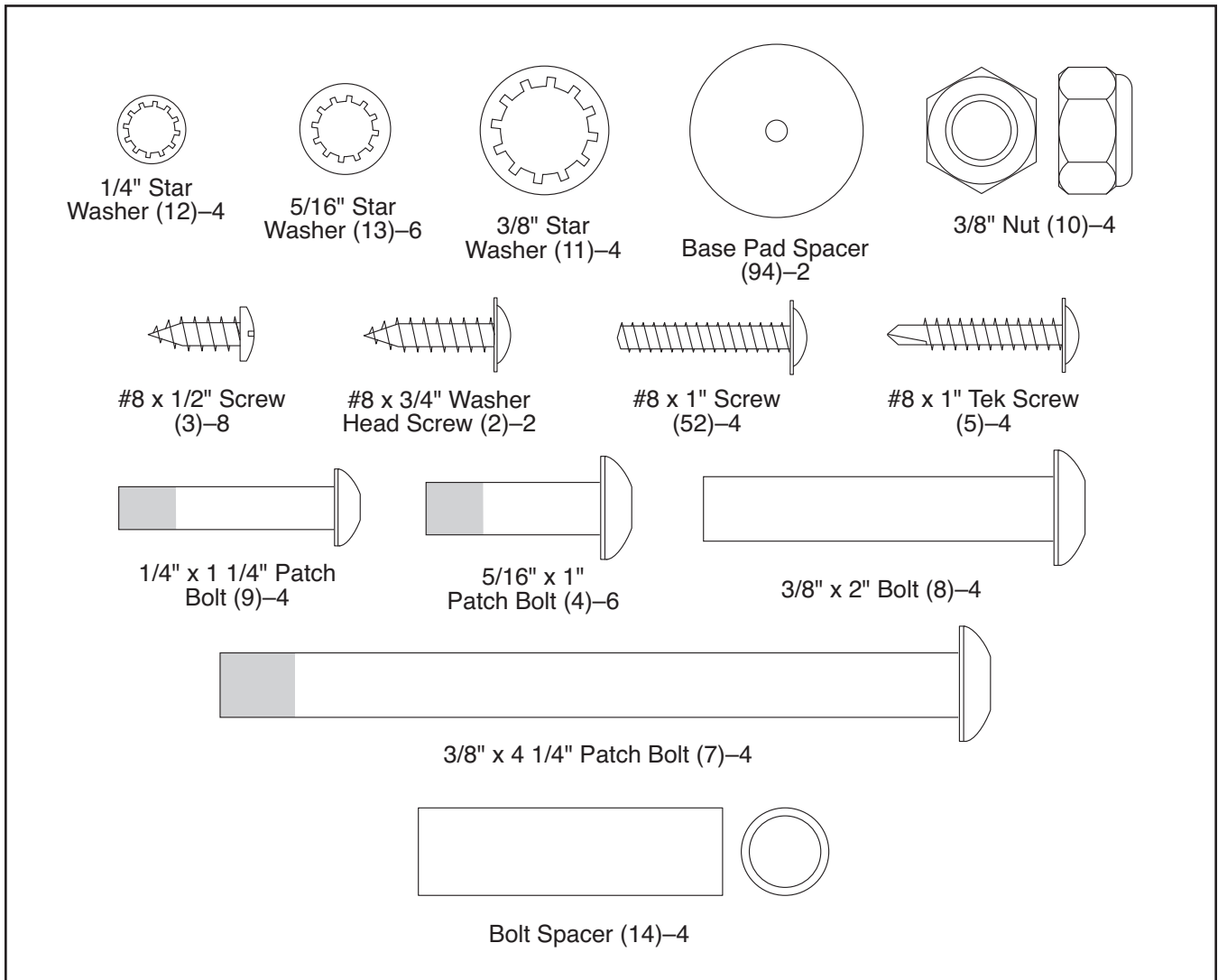

1. **Make sure that the power cord is unplugged.**

With the help of a second person, carefully tip the treadmill onto its left side. Partially fold the Frame (55) so that the treadmill is more stable; **do not fully fold the Frame yet.**

Remove and discard the two indicated bolts (A) and the shipping bracket (B).

Cut the shipping tie securing the Upright Wire (87) to the Base (95). Locate a plastic tie in the indicated hole in the Base, and use the tie to pull the Upright Wire out of the hole.

Attach two Base Pads (90) to the Base (95) in the locations shown with two #8 x 1" Tek Screws (5) and two Base Pad Spacers (94).

Then, attach the other two Base Pads (90) with two #8 x 1" Tek Screws (5).

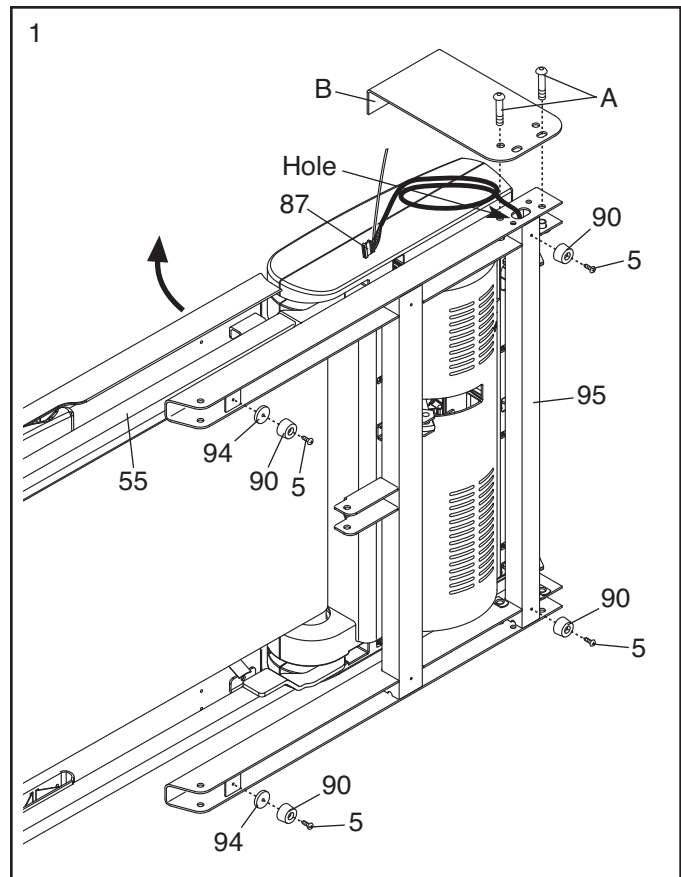

2. Attach a Wheel (96) to the Base (95) with a 3/8" x 2" Bolt (8) and a 3/8" Nut (10). **Do not over-tighten the Nut; the Wheel must turn freely.**

Press a Base Cap (89) into the Base (95).

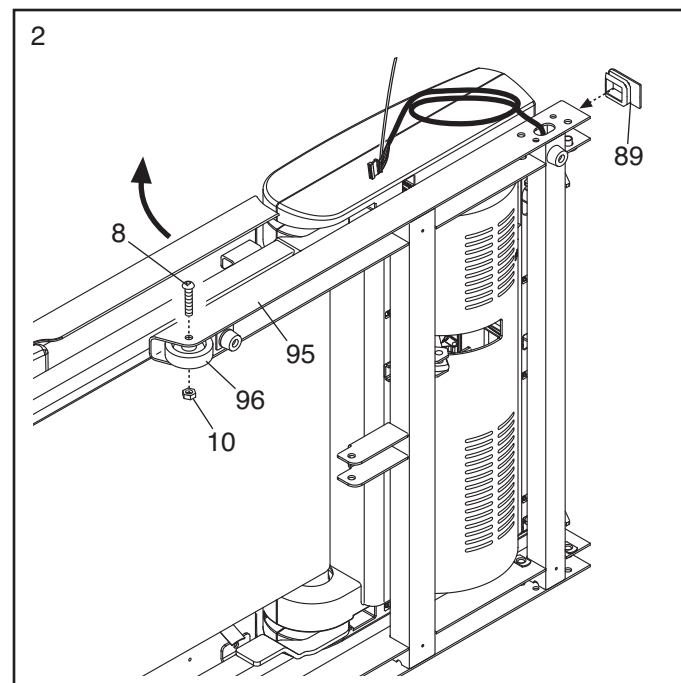

3. Identify the Right Upright (85) and the Right Upright Spacer (91), which are marked with "Right" stickers. Align the oval hole in the Right Upright Spacer with the oval hole in the Base (95). If the holes do not line up, turn the Right Upright Spacer and try again.

Insert the Upright Wire (87) through the Right Upright Spacer (91) as shown. Set the Right Upright Spacer on the Base (95).

Have a second person hold the Right Upright (85) near the Base (95). **See the inset drawing.** Tie the wire tie in the Right Upright securely around the end of the Upright Wire (87). Then, pull the other end of the wire tie until the Upright Wire is routed completely through the Right Upright.

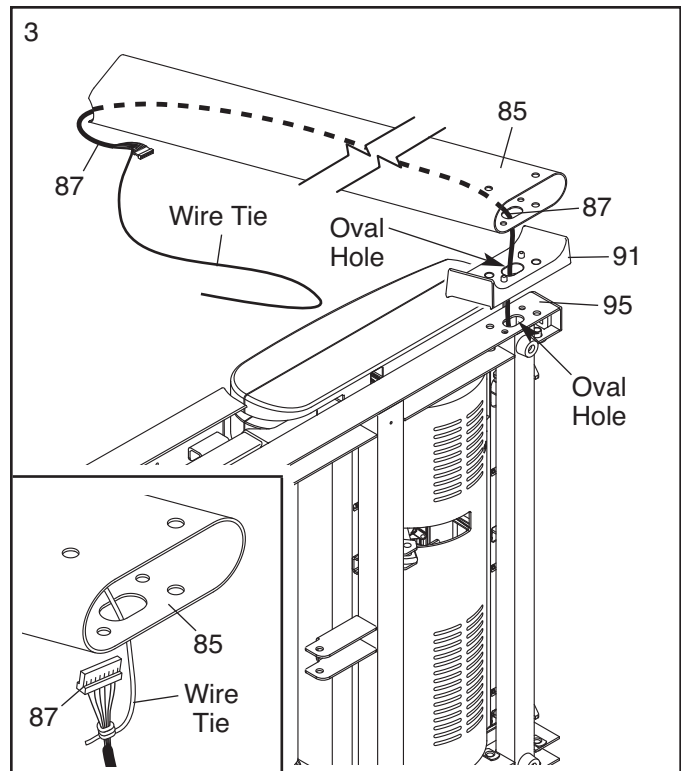

4. Hold a Bolt Spacer (14) inside the lower end of the Right Upright (85). Insert a 3/8" x 4 1/4" Patch Bolt (7) with a 3/8" Star Washer (11) into the Right Upright and the Bolt Spacer. **Repeat this step with a second Bolt Spacer (14), 3/8" x 4 1/4" Patch Bolt (7), and 3/8" Star Washer (11).**

Hold the Right Upright (85) against the Right Upright Spacer (91). **Be careful not to pinch the Upright Wire (87).** Tighten the 3/8" x 4 1/4" Patch Bolts (7) until the heads of the Patch Bolts touch the Right Upright; **do not fully tighten the Patch Bolts yet.**

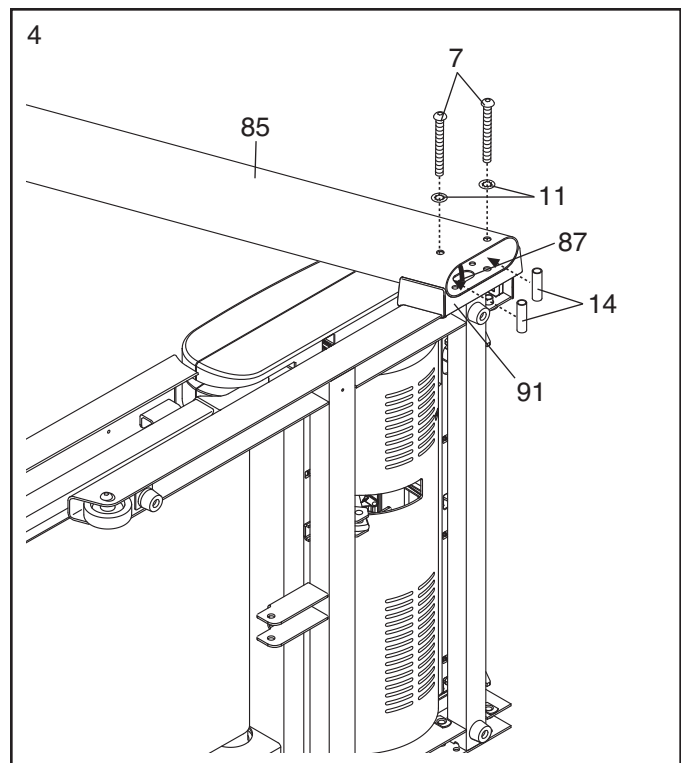



5. With the help of a second person, carefully tip the treadmill onto its right side. Partially fold the Frame (55) so that the treadmill is more stable; **do not fully fold the Frame yet.**

Remove and discard the two indicated bolts (A) and the shipping bracket (B).

Attach a Wheel (96) to the Base (95) with a 3/8" x 2" Bolt (8) and a 3/8" Nut (10). **Do not over-tighten the Nut; the Wheel must turn freely.**

Press a Base Cap (89) into the Base (95).

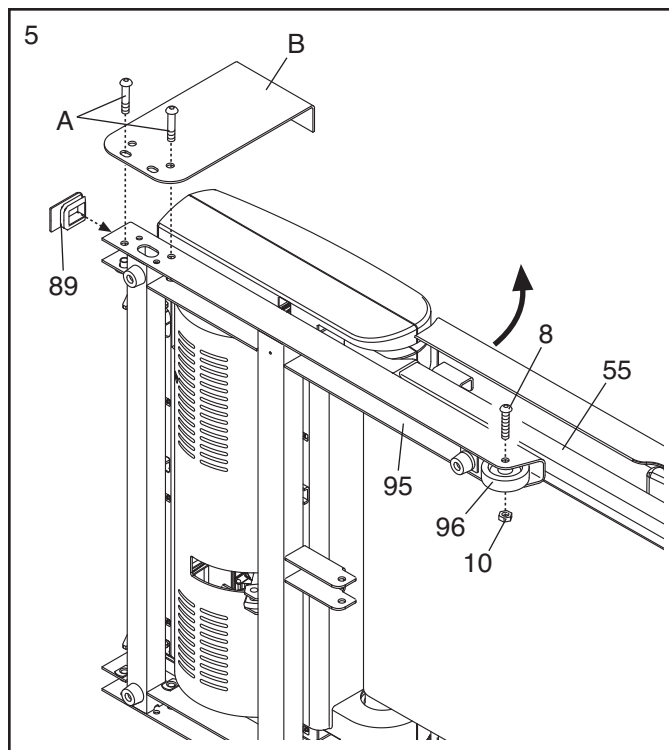

6. Align the oval hole in the Left Upright Spacer (88) with the oval hole in the Base (95) as described in step 3.

Hold a Bolt Spacer (14) inside the lower end of the Left Upright (84). Insert a 3/8" x 4 1/4" Patch Bolt (7) with a 3/8" Star Washer (11) into the Left Upright and the Bolt Spacer. **Repeat this step with a second Bolt Spacer (14), 3/8" x 4 1/4" Patch Bolt (7), and 3/8" Star Washer (11).**

Hold the Left Upright Spacer (88) and the Left Upright (84) against the Base (95). Tighten the 3/8" x 4 1/4" Patch Bolts (7) until the heads of the Patch Bolts touch the Left Upright; **do not fully tighten the Patch Bolts yet.**

With the help of a second person, tip the treadmill so that the Base (95) is flat on the floor.

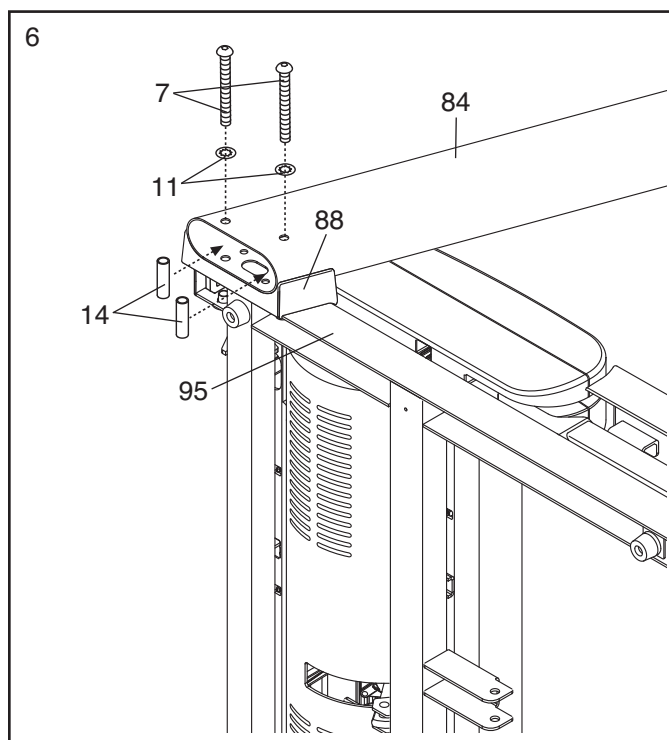

7. Insert the bracket on the Left Handrail (82) into the Left Upright (84).

Insert the Upright Wire (87) several inches downward into the Right Upright (85); **make sure that the wire tie does not fall into the Right Upright**. Then, insert the Right Handrail (83) into the Right Upright. **Be careful not to pinch the Upright Wire**.

Orient the Console Frame (102) as shown, with the welded nuts on the bottom. Insert the ends of the Console Frame into the Left and Right Handrails (82, 83). Attach the Console Frame with four 1/4" x 1 1/4" Patch Bolts (9) and four 1/4" Star Washers (12). **Start all four Patch Bolts, and then tighten all of them.**

Lift the Console Frame (102) and the Handrails (82, 83) off the Uprights (84, 85). Then, pull the Upright Wire (87) out of the Right Upright.

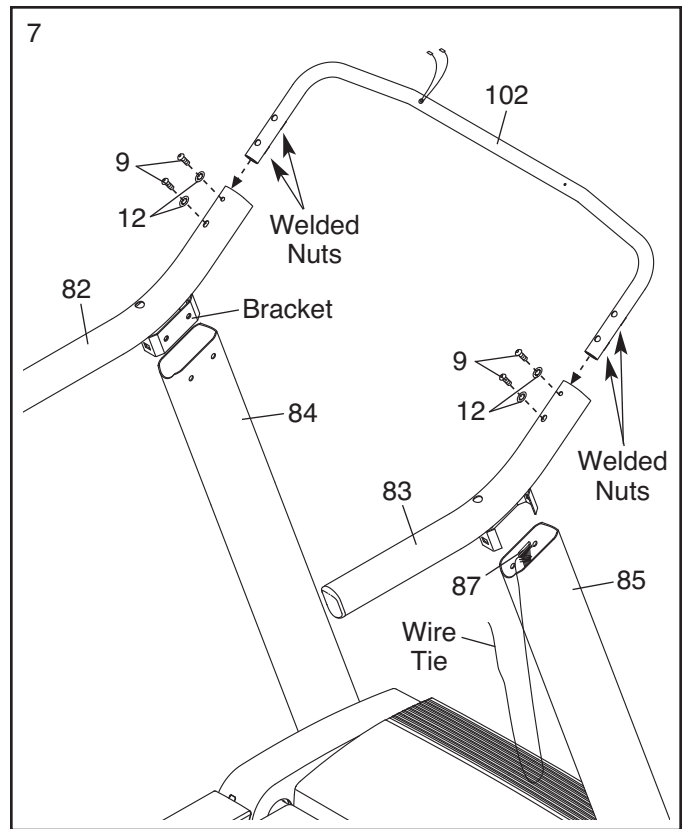

8. Set the console assembly (A) face-down on a soft surface to avoid scratching the console. Attach the Left Accessory Tray (103) with four #8 x 1/2" Screws (3). **Start all four Screws, and then tighten all of them.**

**Attach the Right Accessory Tray (104) in the same way.**

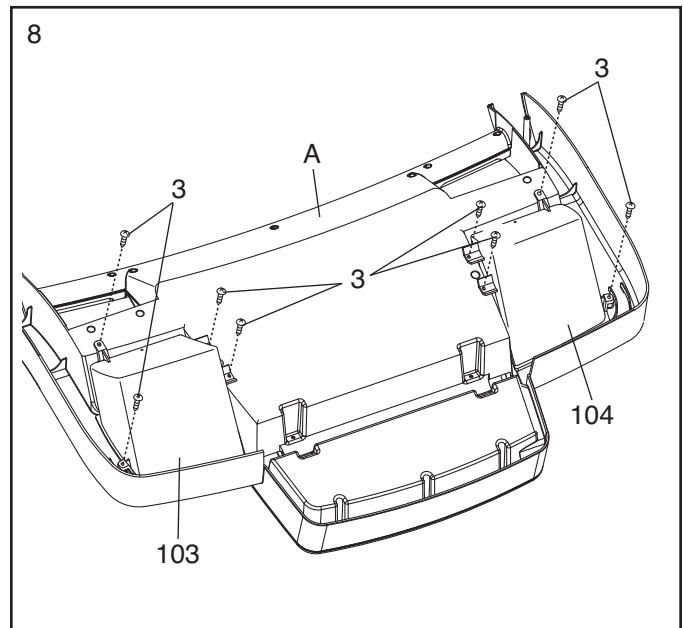

9. With the help of a second person, hold the handrail assembly (B) upside-down near the console assembly (A). Connect the Console Ground Wires (6) in the handrail assembly to the ground wires in the console assembly.

Insert the console wire (C) into the track in the console assembly (A).

Insert the Console Ground Wires (6) into the hole in the console assembly (A) as you set the handrail assembly (B) in the console assembly. **Make sure that the console wire (C) stays in the track. Be careful not to pinch any wires.**

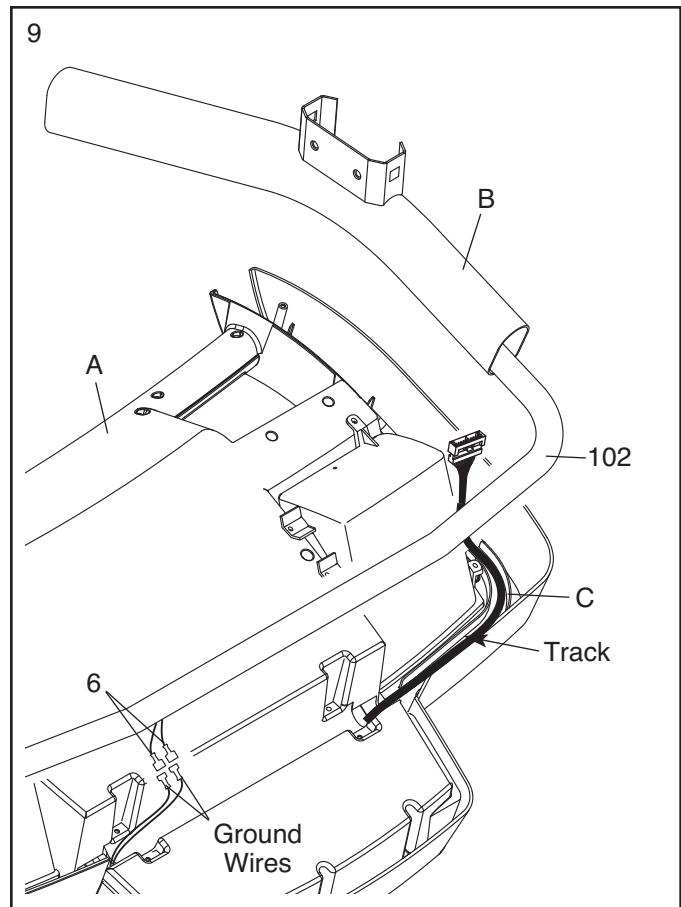

10. Attach the handrail assembly (B) to the console assembly (A) with two #8 x 3/4" Washer Head Screws (2). **Start both Washer Head Screws, and then tighten both of them. Be careful not to overtighten the Washer Head Screws.**

Attach a Console Clamp (105) to the console assembly (A) with two #8 x 1" Screws (52). **Start both Screws, and then tighten both of them. Be careful not to overtighten the Screws.** Attach the other Console Clamp (105) in the same way.

Remove the wire ties from the Handrails (82, 83). Press the 5/16" Cage Nuts (38) back into place, if necessary.

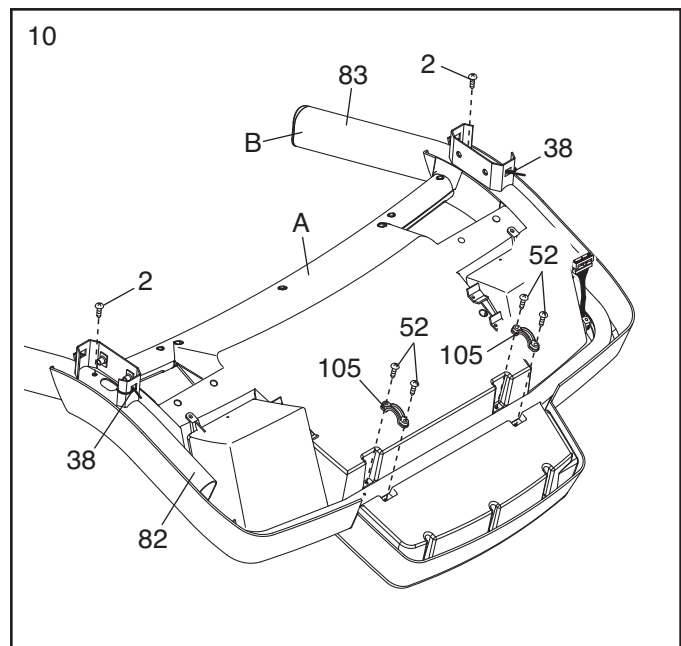

11. Slide the Left Upright Cover (80) onto the Left Upright (84).

Slide the Right Upright Cover (86) onto the Right Upright (85).

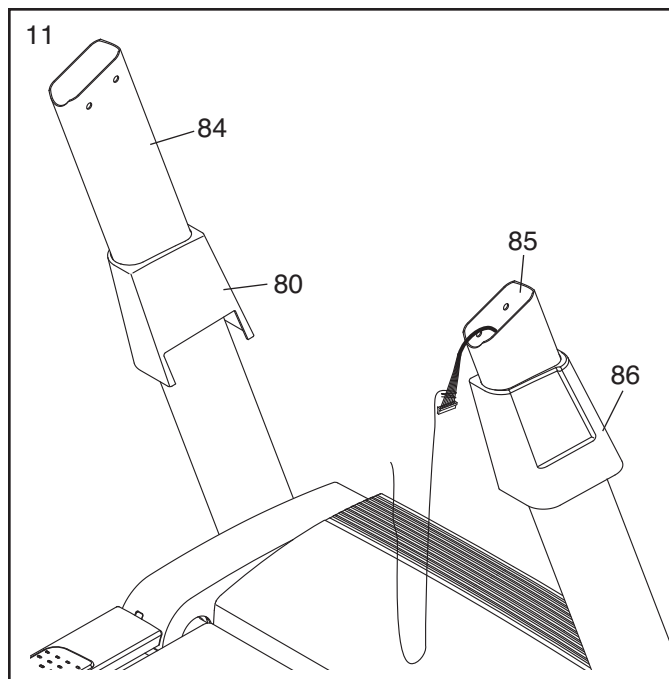

12. With the help of a second person, hold the console assembly (A) near the Right Upright (85) and the Left Upright (not shown). Insert the Upright Wire (87) into the hole in the bottom of the Right Handrail and out of the end as shown.

Connect the Upright Wire (87) to the console wire (C). **See the inset drawing. The connectors should slide together easily and snap into place.** If they do not, turn one connector and try again. **IF THE CONNECTORS ARE NOT CONNECTED PROPERLY, THE CONSOLE MAY BE DAMAGED WHEN YOU TURN ON THE POWER.** Remove the wire tie from the Upright Wire.

Set the console assembly (A) on the Right Upright (85) and the Left Upright (not shown). **Be careful not to pinch any wires.**

**Insert the wires into the Right Handrail (83).** Press a Handrail Cap (63) into the end of the Right Handrail and the Left Handrail (not shown). **Make sure that the console wire (C) is in the notch in the right Handrail Cap.**

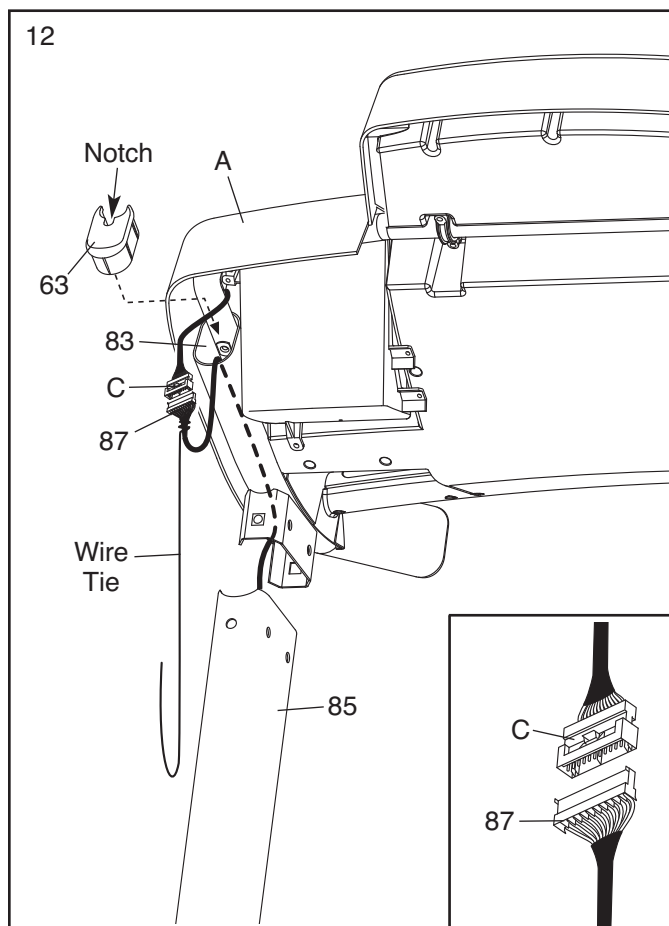

13. Attach the console assembly (A) to the Left Upright (84) and the Right Upright (85) with six 5/16" x 1" Patch Bolts (4) and six 5/16" Star Washers (13). **Start all six Patch Bolts, and then tighten all of them.**

**See steps 4 and 6.** Tighten the 3/8" x 4 1/4" Patch Bolts (7).

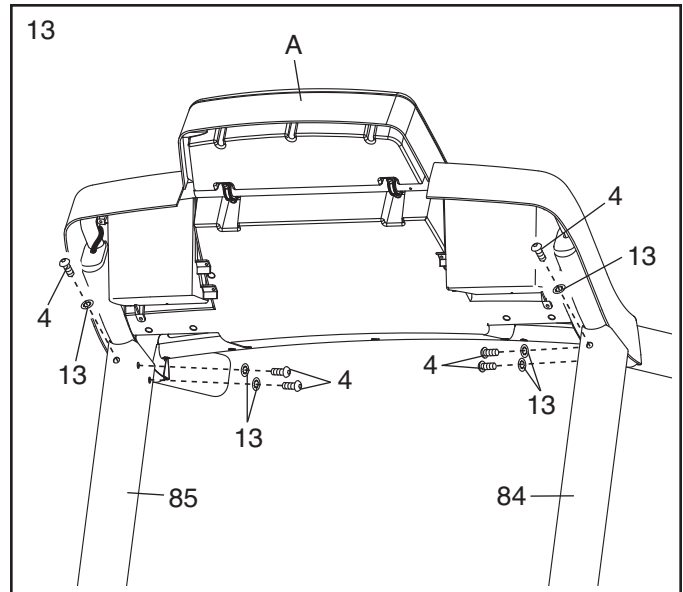

14. Raise the Frame (55) to the position shown. **Have a second person hold the Frame until this step is completed.**

Orient the Storage Latch (51) so that the large barrel and the latch knob are oriented as shown.

Attach the upper end of the Storage Latch (51) to the bracket on the Frame (55) with a 3/8" x 2" Bolt (8) and a 3/8" Nut (10).

Attach the lower end of the Storage Latch (51) to the bracket on the Base (95) with a 3/8" x 2" Bolt (8) and a 3/8" Nut (10). Note: It may be necessary to move the Frame (55) back and forth to align the Storage Latch with the Base.

Lower the Frame (55) (see HOW TO LOWER THE TREADMILL FOR USE on page 21).

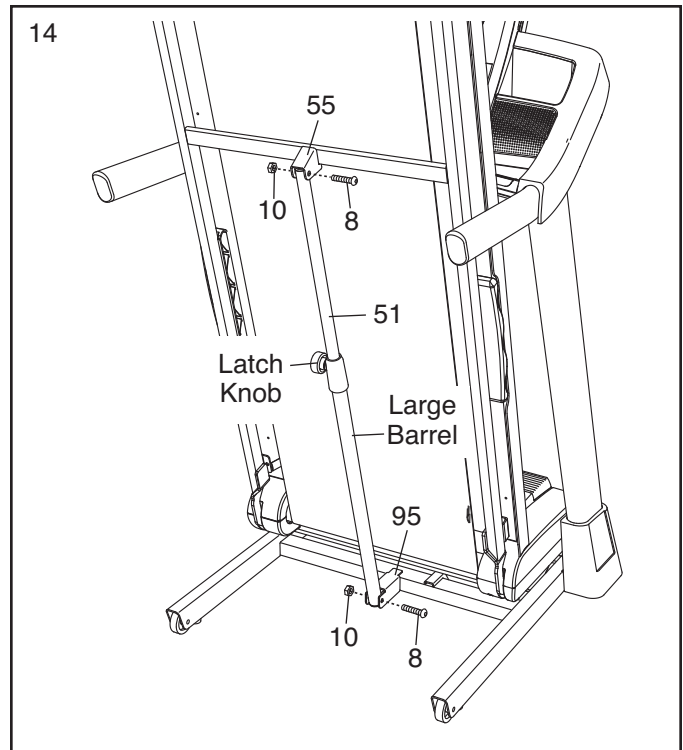

15. **Make sure that all parts are properly tightened before you use the treadmill.** If there are sheets of plastic on the treadmill decals, remove the plastic. To protect the floor or carpet, place a mat under the treadmill. Note: Extra hardware may be included. Keep the included hex key in a secure place; the hex key is used to adjust the walking belt (see pages 23 and 24).

# OPERATION AND ADJUSTMENT

## THE PRE-LUBRICATED WALKING BELT

Your treadmill features a walking belt coated with high-performance lubricant. **IMPORTANT: Never apply silicone spray or other substances to the walking belt or the walking platform. Such substances will cause excessive wear.**

## HOW TO PLUG IN THE POWER CORD

**⚠ DANGER:** Improper connection of the equipment-grounding conductor increases the risk of electric shock. Check with a qualified electrician or serviceman if you are unsure whether the product is properly grounded. Do not modify the plug—if it will not fit the outlet, have a proper outlet installed by a qualified electrician.

Your treadmill, like other electronic equipment, can be damaged by sudden voltage changes in your home's power. **To decrease the risk of damaging your treadmill, always use a surge suppressor with your treadmill (see drawing 1 at the right). To purchase a surge suppressor, see precaution 12 on page 3.**

**Use only a single-outlet surge suppressor that is UL 1449 listed as a transient voltage surge suppressor (TVSS). The surge suppressor must have a UL suppressed voltage rating of 400 volts or less and a minimum surge dissipation of 450 joules. The surge suppressor must be electrically rated for 120 volts AC and 15 amps. There must be a monitoring light on the surge suppressor to indicate whether it is functioning properly. Failure to use a properly functioning surge suppressor could damage the control system of the treadmill (see precaution 13 on page 3).**

**This product must be grounded.** If it should malfunction or break down, grounding provides a path of least resistance for electric current to reduce the risk of electric shock. This product's power cord has an equipment-grounding conductor and a grounding plug. **Plug the power cord into a surge suppressor, and plug the surge suppressor into an appropriate outlet**

that is properly installed and grounded in accordance with all local codes and ordinances. **IMPORTANT: The treadmill is not compatible with GFCI-equipped outlets.**

This product is for use on a nominal 120-volt circuit (see drawing 1). A temporary adapter may be used to connect the surge suppressor to a 2-pole receptacle if a properly grounded outlet is not available (see drawing 2).

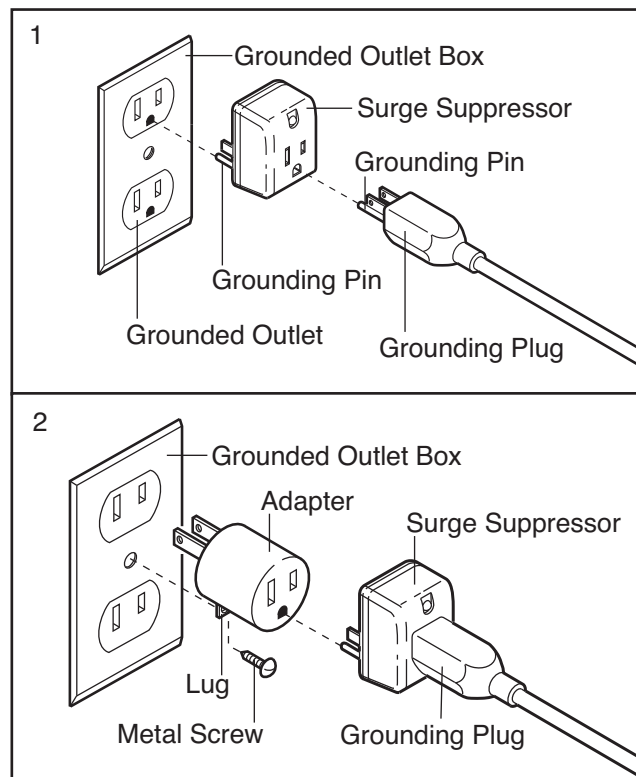

The temporary adapter should be used only until a properly grounded outlet (see drawing 1) can be installed by a qualified electrician.

The green-colored rigid ear, lug, or the like extending from the adapter must be connected to a permanent ground such as a properly grounded outlet box cover. The adapter must be held in place by a metal screw. **Some 2-pole receptacle outlet box covers are not grounded. Contact a qualified electrician to determine if the outlet box cover is grounded before using an adapter.**

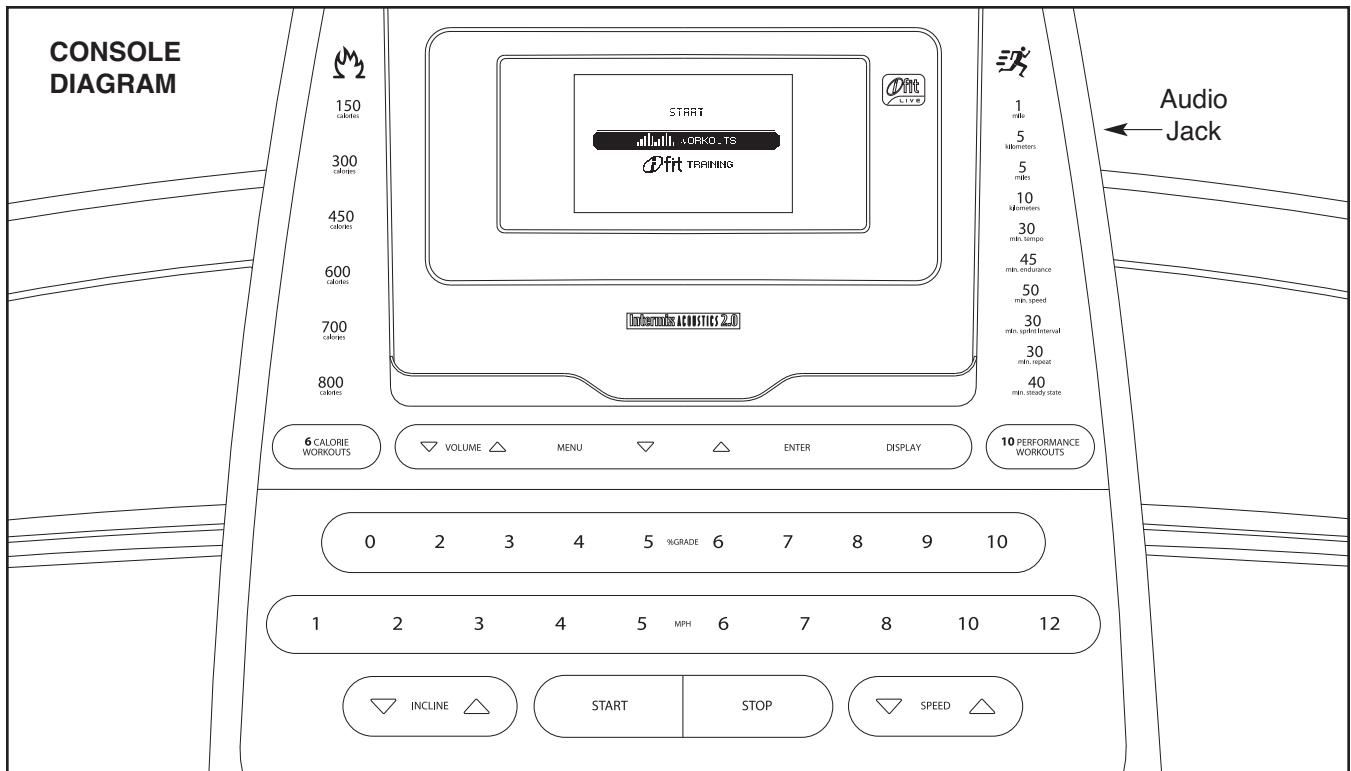

## FEATURES OF THE CONSOLE

The treadmill console offers an impressive array of features designed to make your workouts more effective and enjoyable. When you use the manual mode of the console, you can change the speed and incline of the treadmill with the touch of a button. As you exercise, the console will display continuous exercise feedback. You can even measure your heart rate using the handgrip pulse sensor.

In addition, the console features sixteen preset workouts—six calorie workouts and ten performance workouts. Each preset workout automatically controls the speed and incline of the treadmill as it guides you through an effective exercise session.

The console also features an iFit training mode that enables the treadmill to communicate with your wireless network through an optional iFit Live module. With the iFit training mode, you can download personalized workouts, create your own workouts, track your workout results, and access many other features. **To purchase an iFit Live module at any time, go to [www.ifit.com](http://www.ifit.com) or call the telephone number on the front cover of this manual.**

You can even listen to your favorite workout music or audio books with the console's stereo sound system.

**To turn on the power**, see page 16. **To use the manual mode**, see page 16. **To use a preset workout**, see page 18. **To use the iFit training mode**, see page 19. **To use the information mode**, see page 20. **To use the stereo sound system**, see page 20.

**IMPORTANT:** If there is a sheet of plastic on the console, remove the plastic. To prevent damage to the walking platform, wear clean athletic shoes while using the treadmill. The first time the treadmill is used, observe the alignment of the walking belt, and center the walking belt if necessary (see page 24).

Note: The console can display speed and distance in either miles or kilometers. To find which unit of measurement is selected, see THE INFORMATION MODE on page 20. **For simplicity, all instructions in this manual refer to miles.**

## HOW TO TURN ON THE POWER

**IMPORTANT:** If the treadmill has been exposed to cold temperatures, allow it to warm to room temperature before turning on the power. If you do not do this, you may damage the console displays or other electrical components.

Plug in the power cord (see page 14). Next, locate the reset/off circuit breaker on the treadmill frame near the power cord. Make sure that the circuit breaker is in the reset position.

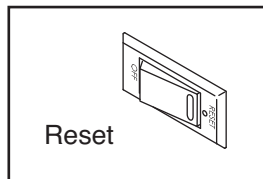

**IMPORTANT:** The console features a display demo mode, designed to be used if the treadmill is displayed in a store. If the displays light as soon as you plug in the power cord and switch the reset/off circuit breaker to the reset position, the demo mode is turned on. To turn off the demo mode, hold down the Stop button for a few seconds. If the displays remain lit, see THE INFORMATION MODE on page 20 to turn off the demo mode.

Next, stand on the foot rails of the treadmill. Locate the clip attached to the key (see the drawing at the right), and slide the clip securely onto the waistband of your clothes. Then, insert the key into the console. After a moment, the displays will light. **IMPORTANT:** In an emergency, the key can be pulled from the console, causing the walking belt to slow to a stop. Test the clip by carefully taking a few steps backward; if the key is not pulled from the console, adjust the position of the clip.

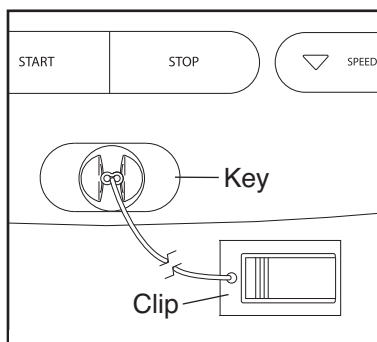

## HOW TO USE THE MANUAL MODE

### 1. Insert the key into the console.

See HOW TO TURN ON THE POWER at the left.

### 2. Select the manual mode.

Each time the key is inserted, the main menu will appear. To select the manual mode, use the increase and decrease buttons next to the Enter button and highlight START. Press the Enter button. If you have selected a workout or the iFit training mode, press the Menu button to return to the main menu.

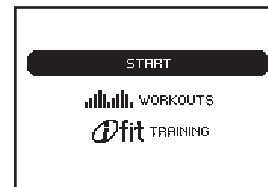

### 3. Start the walking belt and adjust the speed.

To start the walking belt, press the Start button, the Speed increase button, or one of the numbered speed buttons.

If you press the Start button or the Speed increase button, the walking belt will begin to move at 1 mph. As you exercise, change the speed of the walking belt as desired by pressing the Speed increase and decrease buttons. Each time you press one of the buttons, the speed setting will change by 0.1 mph; if you hold down the button, the speed setting will change in increments of 0.5 mph.

If you press one of the numbered speed buttons, the walking belt will gradually change speed until it reaches the selected speed setting. To select a speed setting that includes a decimal—such as 3.5 mph—press two numbered buttons in succession. For example, to select a speed setting of 3.5 mph, press the 3 button and then immediately press the 5 button.

To stop the walking belt, press the Stop button. To restart the walking belt, press the Start button, the Speed increase button, or one of the numbered speed buttons.



#### 4. Change the incline of the treadmill as desired.

To change the incline of the treadmill, press the Incline increase or decrease button, or one of the incline buttons numbered 0 to 10. Each time you press one of the buttons, the incline will gradually change until it reaches the selected incline setting.

#### 5. Select a display mode and monitor your progress with the display.

The console offers several display modes. The display mode that you select will determine which workout information is shown. To select the desired display mode, press the Display button repeatedly.

As you walk or run on the treadmill, the display can show the following workout information:

- The incline level of the treadmill
- The speed of the walking belt
- The distance that you have walked or run
- The elapsed time
- Your pace in minutes per mile or minutes per kilometer
- The approximate number of calories you have burned
- Your heart rate (see step 6 on this page)

Regardless of which display mode you select, the speed and incline settings will appear in the display for a few seconds each time you change the setting.

#### 6. Measure your heart rate if desired.

Before using the handgrip pulse sensor, remove the sheets of plastic from the metal contacts. In addition, make sure that your hands are clean.

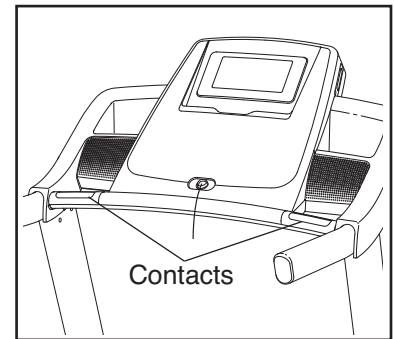

To measure your heart rate, **stand on the foot rails and hold the contacts—avoid moving your hands.** When your pulse is detected, your heart rate will be shown. **For the most accurate heart rate reading, continue to hold the contacts for about 15 seconds.**

#### 7. When you are finished exercising, remove the key from the console.

Step onto the foot rails, press the Stop button, and **adjust the incline of the treadmill to the lowest setting. The incline must be at the lowest setting when you fold the treadmill to the storage position, or you may damage the treadmill.** Next, remove the key from the console and put it in a secure place.

When you are finished using the treadmill, switch the reset/off circuit breaker to the off position and unplug the power cord. **IMPORTANT: If you do not do this, the treadmill's electrical components may wear prematurely.**

## HOW TO USE A PRESET WORKOUT

### 1. Insert the key into the console.

See HOW TO TURN ON THE POWER on page 16.

### 2. Select a preset workout.

If you have selected the manual mode, a workout, or the iFit training mode, press the Menu button to return to the main menu.

To select a preset workout, use the increase and decrease buttons next to the Enter button and highlight WORKOUTS. Press the Enter button. Then, press the increase and decrease buttons to highlight the desired workout category and press the Enter button. You can also press the 6 Calorie Workouts button or the 10 Performance Workouts button.

If you select a performance workout, use the increase and decrease buttons to highlight the desired workout category and press the Enter button.

Use the increase and decrease buttons to select the desired workout. When you select a workout, the display will show the name, the duration, the maximum speed setting, the maximum incline setting, and a profile of the speed settings of the workout. Press the Enter button. Note: When a distance workout is selected, the duration of the workout will not appear in the display.

### 3. Start the workout.

Press the Start button or the Speed increase button to start the workout. A moment after you press

the button, the treadmill will automatically adjust to the first speed and incline settings of the workout. Hold the handrails and begin walking.

Each preset workout is divided into segments. One speed setting and one incline setting are programmed for each segment. Note: The same speed and/or incline setting may be programmed for consecutive segments.

During the workout, the profile will show your progress. The flashing segment of the profile represents the current segment of the workout. The height of the flashing segment indicates the speed setting for the current segment.

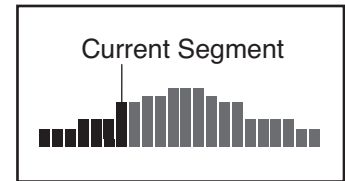

At the end of each segment, a series of tones will sound. If a new speed and/or incline setting is programmed for the next segment, the speed and/or incline will appear in the display and the treadmill will automatically adjust to the new speed and incline settings.

The workout will continue in this way until the last segment of the profile flashes in the display and the last segment ends. The walking belt will then slow to a stop. Note: When a distance workout ends, a cool down mode will begin and the walking belt will gradually slow to a stop.

**Note: The calorie goal for each calorie workout is an estimate of the number of calories that you will burn during the workout. The actual number of calories that you burn will depend on your weight. In addition, if you manually change the speed or incline of the treadmill during the workout, the number of calories you burn will be affected.**

If the speed or incline setting is too high or too low at any time during the workout, you can manually override the setting by pressing the speed or incline buttons; **however, when the next segment of the workout begins, the treadmill will automatically adjust to the speed and incline settings for the next segment.**

To stop the workout at any time, press the Stop button. To restart the workout, press the Start button or the Speed increase button. The walking belt will begin to move at 1 mph. When the next segment of the workout begins, the treadmill will automatically adjust to the speed and incline settings for the next segment.

**4. Select a display mode and monitor your progress with the display.**

See step 5 on page 17.

**5. Measure your heart rate if desired.**

See step 6 on page 17.

**6. When you are finished exercising, remove the key from the console.**

See step 7 on page 17.

## HOW TO USE THE iFIT TRAINING MODE

The optional iFit Live module allows your treadmill to communicate with your wireless network and unlocks exciting new features. For example, you can download personalized workouts, create your own workouts, track your workout results, and access many other features. **To purchase an iFit Live module at any time, go to [www.iFit.com](http://www.iFit.com) or call the telephone number on the front cover of this manual.**

To use the iFit training mode, insert the iFit Live module into the console. Use the increase and decrease buttons next to the Enter button and highlight iFIT TRAINING. Press the Enter button.

For more information on the iFit training mode, go to [www.iFit.com](http://www.iFit.com). Note: To use an iFit Live module, you must have access to a computer with an internet connection and a USB port. You must also have your own wireless network including an 802.11b router with SSID broadcast enabled (hidden networks are not supported). You will also need an iFit.com membership.

## THE INFORMATION MODE

The console features an information mode that keeps track of the total distance that the walking belt has moved and the total number of hours that the treadmill has been used. You can also select miles or kilometers to measure distance, turn on or turn off the display demo mode, adjust the contrast level of the display, and view the status of the optional iFit Live module.

To select the information mode, hold down the Stop button, insert the key into the console, and then release the Stop button. When the information mode is selected, the following information will appear in the display:

The display will show the total number of miles that the walking belt has moved and the total number of hours the treadmill has been used.

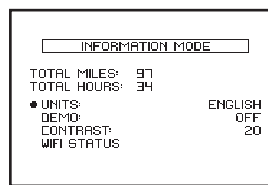

The display will show the selected unit of measurement. To change the unit of measurement, press the Speed increase button. To view distance in miles, select ENGLISH. To view distance in kilometers, select METRIC.

The console features a display demo mode, designed to be used if the treadmill is displayed in a store. While the demo mode is turned on, the console will function normally when you plug in the power cord, switch the reset/off circuit breaker to the "reset" position, and insert the key into the console. However, when you remove the key, the displays will remain lit, although the buttons will not function. If the demo mode is turned on, the word "ON" will appear in display while the information mode is selected. To turn on or turn off the demo mode, press the Speed decrease button.

The display will also show the contrast level of the display. Press the Incline increase and decrease buttons to adjust the contrast.

The display will show whether an accessory is plugged into the console. If the iFit Live module is plugged in, the display will show the words "WIFI STATUS." If a USB module is plugged in, the display will show the words "USB STATUS." If nothing is plugged in, the display will show the words "NO MODULE DETECTED."

To exit the information mode, remove the key from the console.

## HOW TO USE THE STEREO SOUND SYSTEM

To play music or audio books through the console's stereo speakers, you must connect your MP3 player, CD player, or other personal audio player to the console. Locate the audio wire and plug it into the audio jack on the side of the console. Then, plug the other end into a jack on your MP3 player, CD player, or other personal audio player. **Make sure that the audio wire is fully plugged in.**

Next, press the Play button on your MP3 player, CD player, or other personal audio player. Then, adjust the volume on your personal audio player or press the Volume increase and decrease buttons on the console.

If you are using a personal CD player and the CD skips, set the CD player on the floor or another flat surface instead of on the console.

# HOW TO FOLD AND MOVE THE TREADMILL

## HOW TO FOLD THE TREADMILL

To avoid damaging the treadmill, adjust the incline to the lowest position before you fold the treadmill. Then, remove the key and unplug the power cord. **CAUTION:** You must be able to safely lift 45 lbs. (20 kg) to raise, lower, or move the treadmill.

1. Hold the metal frame firmly in the location shown by the arrow below. **CAUTION:** Do not hold the frame by the plastic foot rails. Make sure to bend your legs and keep your back straight.

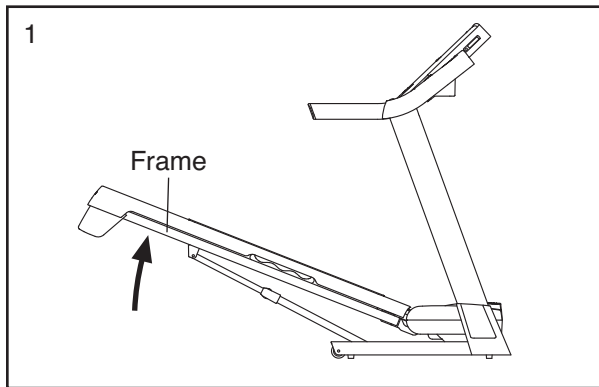

2. Raise the frame until the latch knob locks in the storage position. **CAUTION:** Make sure that the latch knob locks.

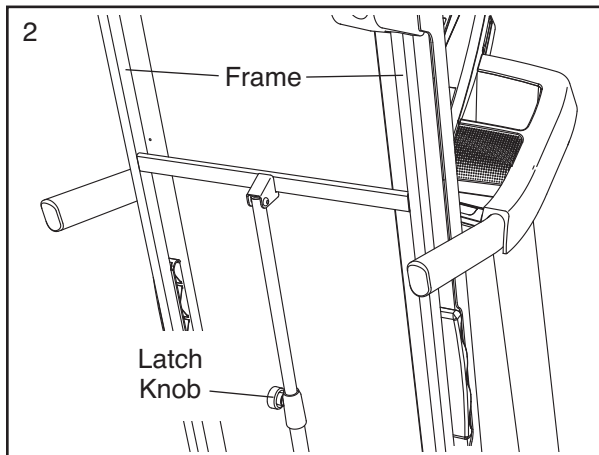

To protect the floor or carpet, place a mat under the treadmill. Keep the treadmill out of direct sunlight. Do not leave the treadmill in the storage position in temperatures above 85° F (30° C).

## HOW TO MOVE THE TREADMILL

Before moving the treadmill, fold it as described at the left. **CAUTION:** Make sure that the latch knob is locked in the storage position. Moving the treadmill may require two persons.

1. Hold the frame and one of the handrails, and place one foot against a wheel.

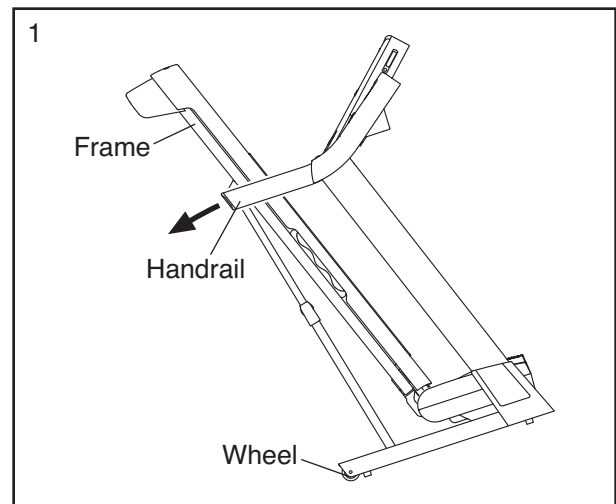

2. Pull back on the handrail until the treadmill will roll on the wheels, and carefully move the treadmill to the desired location. **CAUTION:** Do not move the treadmill without tipping it back, do not pull on the frame, and do not move the treadmill over an uneven surface.
3. Place one foot against a wheel, and carefully lower the treadmill.

## HOW TO LOWER THE TREADMILL FOR USE

1. **See drawing 2.** Hold the upper end of the treadmill with your right hand. Pull the latch knob to the left; if necessary, push the frame forward slightly. Pivot the frame downward a few inches, and release the latch knob.
2. **See drawing 1 at the left.** Hold the metal frame firmly with both hands, and lower it to the floor. **CAUTION:** Do not hold the frame by the plastic foot rails, and do not drop the frame. Make sure to bend your legs and keep your back straight.

# TROUBLESHOOTING

Most treadmill problems can be solved by following the simple steps below. Find the symptom that applies, and follow the steps listed. If further assistance is needed, see the front cover of this manual.

**PROBLEM: The power does not turn on**

**SOLUTION:** a. Make sure that the power cord is plugged into a surge suppressor, and that the surge suppressor is plugged into a properly grounded outlet (see page 14). Use only a single-outlet surge suppressor that meets all of the specifications described on page 14. **IMPORTANT: The treadmill is not compatible with GFCI-equipped outlets.**

b. After the power cord has been plugged in, make sure that the key is inserted into the console.

c. Check the reset/off circuit breaker located on the treadmill frame near the power cord. If the switch protrudes as shown, the circuit breaker has tripped. To reset the circuit breaker, wait for five minutes and then press the switch back in.

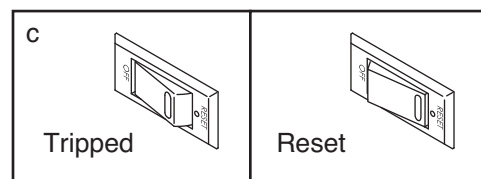

**PROBLEM: The power turns off during use**

**SOLUTION:** a. Check the reset/off circuit breaker (see the drawing above). If the circuit breaker has tripped, wait for five minutes and then press the switch back in.

b. Make sure that the power cord is plugged in. If the power cord is plugged in, unplug it, wait for five minutes, and then plug it back in.

c. Remove the key from the console. Reinsert the key into the console.

d. If the treadmill still will not run, please see the front cover of this manual.

**PROBLEM: The console displays remain lit when you remove the key from the console**

**SOLUTION:** a. The console features a display demo mode, designed to be used if the treadmill is displayed in a store. If the displays remain lit when you remove the key, the demo mode is turned on. To turn off the demo mode, hold down the Stop button for a few seconds. If the displays are still lit, see THE INFORMATION MODE on page 20 to turn off the demo mode.

**PROBLEM: The displays of the console do not function properly**

**SOLUTION:** a. Remove the key from the console and **UNPLUG THE POWER CORD**. With the help of a second person, carefully tip down the Uprights (84, 85). There may be two Hood Screws (A) in the bottom of the Belly Pan (75). If there are, remove them. Note: A Phillips screwdriver with a shaft at least 5 in. (13 cm) long is required.

Then, raise the Uprights (84, 85).

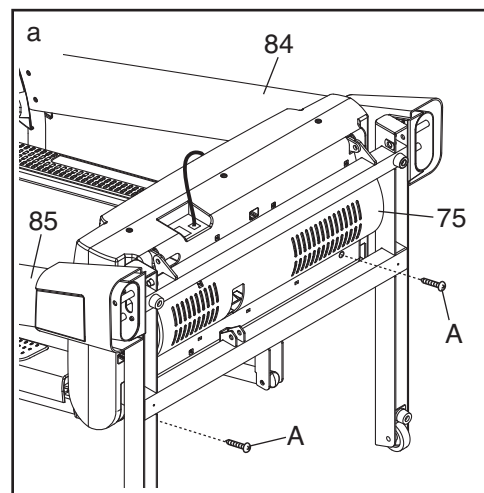

Remove the three #8 x 3/4" Screws (1) and carefully pivot the Motor Hood (62) off.

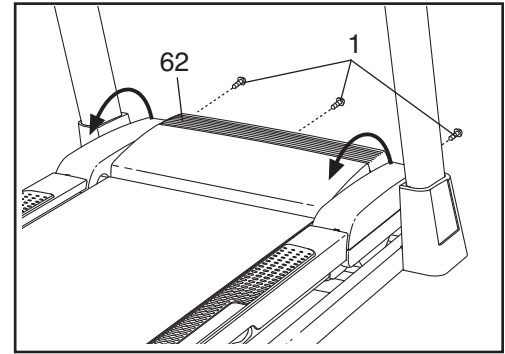

Locate the Reed Switch (73) and the Magnet (47) on the left side of the Pulley (48). Turn the Pulley until the Magnet is aligned with the Reed Switch. **Make sure that the gap between the Magnet and the Reed Switch is about 1/8 in. (3 mm).** If necessary, loosen the #8 x 3/4" Clamp Screw (17), move the Reed Switch slightly, and then retighten the Screw. Reattach the Motor Hood (not shown). Reattach the Hood Screws (not shown) if necessary. Run the treadmill for a few minutes to check for a correct speed reading.

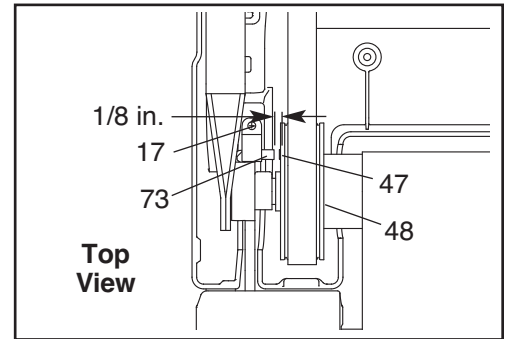

**PROBLEM: The incline of the treadmill does not change correctly**

**SOLUTION:** a. Hold down the Stop button and the Speed increase button, insert the key into the console, and then release the Stop button and the Speed increase button. Press the Stop button and then press the Incline increase or decrease button. The treadmill will automatically rise to the maximum incline level and then return to the minimum level. This will recalibrate the incline system. If the incline does not calibrate, press the Stop button again, and then press the Incline increase or decrease button again. When the incline is calibrated, remove the key from the console.

**PROBLEM: The walking belt slows when walked on**

**SOLUTION:** a. Use only a single-outlet surge suppressor that meets all of the specifications described on page 14.

b. If the walking belt is overtightened, treadmill performance may decrease and the walking belt may become damaged. Remove the key and **UNPLUG THE POWER CORD**. Using the hex key, turn both idler roller bolts counterclockwise, 1/4 of a turn. When the walking belt is properly tightened, you should be able to lift each edge of the walking belt 2 to 3 in. (5 to 7 cm) off the walking platform. Be careful to keep the walking belt centered. Then, plug in the power cord, insert the key, and run the treadmill for a few minutes. Repeat until the walking belt is properly tightened.

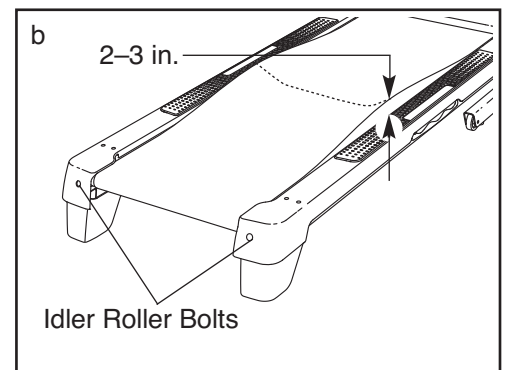

c. If the walking belt still slows when walked on, see the front cover of this manual.

**PROBLEM: The walking belt is off-center or slips when walked on**

**SOLUTION:** a. **If the walking belt is off-center**, first remove the key and **UNPLUG THE POWER CORD**. **If the walking belt has shifted to the left**, use the hex key to turn the left idler roller bolt clockwise 1/2 of a turn; **if the walking belt has shifted to the right**, turn the left idler roller bolt counterclockwise 1/2 of a turn. Be careful not to overtighten the walking belt. Then, plug in the power cord, insert the key, and run the treadmill for a few minutes. Repeat until the walking belt is centered.

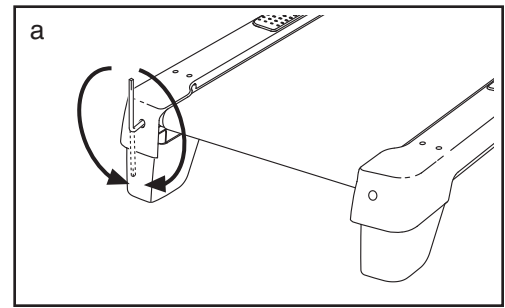

b. **If the walking belt slips when walked on**, first remove the key and **UNPLUG THE POWER CORD**. Using the hex key, turn both idler roller bolts clockwise, 1/4 of a turn. When the walking belt is correctly tightened, you should be able to lift each edge of the walking belt 2 to 3 in. (5 to 7 cm) off the walking platform. Be careful to keep the walking belt centered. Then, plug in the power cord, insert the key, and carefully walk on the treadmill for a few minutes. Repeat until the walking belt is properly tightened.

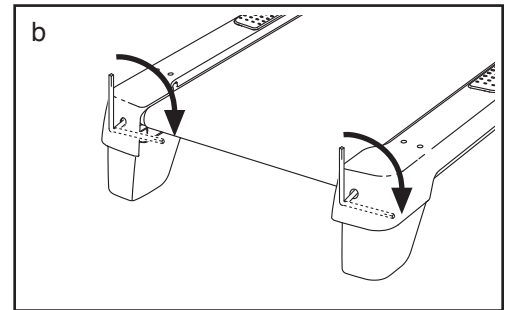



# EXERCISE GUIDELINES

**⚠ WARNING:** Before beginning this or any exercise program, consult your physician. This is especially important for persons over age 35 or persons with pre-existing health problems.

The pulse sensor is not a medical device. Various factors may affect the accuracy of heart rate readings. The pulse sensor is intended only as an exercise aid in determining heart rate trends in general.

These guidelines will help you to plan your exercise program. For detailed exercise information, obtain a reputable book or consult your physician. Remember, proper nutrition and adequate rest are essential for successful results.

## EXERCISE INTENSITY

Whether your goal is to burn fat or to strengthen your cardiovascular system, exercising at the proper intensity is the key to achieving results. You can use your heart rate as a guide to find the proper intensity level. The chart below shows recommended heart rates for fat burning and aerobic exercise.

165	155	145	140	130	125	115	♥
145	138	130	125	118	110	103	♥
125	120	115	110	105	95	90	♥
<hr/>							
20	30	40	50	60	70	80	

To find the proper intensity level, find your age at the bottom of the chart (ages are rounded off to the nearest ten years). The three numbers listed above your age define your “training zone.” The lowest number is the heart rate for fat burning, the middle number is the heart rate for maximum fat burning, and the highest number is the heart rate for aerobic exercise.

**Burning Fat**—To burn fat effectively, you must exercise at a low intensity level for a sustained period of time. During the first few minutes of exercise, your body uses *carbohydrate calories* for energy. Only after the first few minutes of exercise does your body begin to use stored *fat calories* for energy. If your goal is to burn fat, adjust the intensity of your exercise until your heart rate is near the lowest number in your training zone. For maximum fat burning, exercise with your heart rate near the middle number in your training zone.

**Aerobic Exercise**—If your goal is to strengthen your cardiovascular system, you must perform aerobic exercise, which is activity that requires large amounts of oxygen for prolonged periods of time. For aerobic exercise, adjust the intensity of your exercise until your heart rate is near the highest number in your training zone.

## WORKOUT GUIDELINES

**Warming Up**—Start with 5 to 10 minutes of stretching and light exercise. A warm-up increases your body temperature, heart rate, and circulation in preparation for exercise.

**Training Zone Exercise**—Exercise for 20 to 30 minutes with your heart rate in your training zone. (During the first few weeks of your exercise program, do not keep your heart rate in your training zone for longer than 20 minutes.) Breathe regularly and deeply as you exercise—never hold your breath.

**Cooling Down**—Finish with 5 to 10 minutes of stretching. Stretching increases the flexibility of your muscles and helps to prevent post-exercise problems.

## EXERCISE FREQUENCY

To maintain or improve your condition, complete three workouts each week, with at least one day of rest between workouts. After a few months of regular exercise, you may complete up to five workouts each week, if desired. Remember, the key to success is to make exercise a regular and enjoyable part of your everyday life.

# PART LIST—Model No. PFTL66010.0

R0410A

To locate the parts listed below, see the EXPLODED DRAWING near the end of this manual.

Key No.	Qty.	Description	Key No.	Qty.	Description
1	4	#8 x 3/4" Screw	51	1	Storage Latch
2	2	#8 x 3/4" Washer Head Screw	52	4	#8 x 1" Screw
3	32	#8 x 1/2" Screw	53	1	Audio Wire
4	6	5/16" x 1" Patch Bolt	54	1	Right Foot Rail
5	4	#8 x 1" Tek Screw	55	1	Frame
6	2	Console Ground Wire	56	2	Roller Bracket
7	4	3/8" x 4 1/4" Patch Bolt	57	1	Roller Ground Wire
8	4	3/8" x 2" Bolt	58	1	Right Rear Foot
9	4	1/4" x 1 1/4" Patch Bolt	59	1	Left Rear Foot
10	4	3/8" Nut	60	1	Idler Roller
11	4	3/8" Star Washer	61	1	Hex Key
12	4	1/4" Star Washer	62	1	Motor Hood
13	6	5/16" Star Washer	63	2	Handrail Cap
14	4	Bolt Spacer	64	1	Lift Frame
15	9	#8 x 3/4" Tek Screw	65	1	Lift Frame Ground Wire
16	1	Right Speaker	66	1	Drive Motor Belt
17	9	#8 x 3/4" Clamp/Isolator Screw	67	1	Drive Motor
18	1	iFit Live Module Housing	68	1	Controller Ground Wire
19	2	#8 x 1 1/2" Screw	69	1	Power Cord
20	2	5/16" x 1 1/2" Bolt	70	1	Grommet
21	2	M8 x 60mm Bolt	71	1	Reset/Off Circuit Breaker
22	2	3/8" x 1" Patch Bolt	72	1	Controller
23	1	1/4" x 1" Bolt	73	1	Reed Switch
24	2	Idler Roller Bolt	74	1	Reed Switch Clamp
25	1	3/8" x 1 3/4" Bolt	75	1	Belly Pan
26	1	3/8" x 1 1/2" Bolt	76	3	Wire Tie
27	2	3/8" x 3/4" Bolt	77	8	8" Tie
28	8	#8 x 1/2" Ground Screw	78	2	15" Tie
29	1	Incline Sensor Wire	79	4	Releasable Tie
30	14	#12 x 1 1/4" Screw	80	1	Left Upright Cover
31	2	1/4" Motor Bolt	81	2	Lower Handrail Cap
32	4	#8 Belt Guide Screw	82	1	Left Handrail
33	2	1/4" Washer	83	1	Right Handrail
34	2	1/4" Split Washer	84	1	Left Upright
35	4	3/8" Jam Nut	85	1	Right Upright
36	2	5/16" Flange Nut	86	1	Right Upright Cover
37	3	Hood Clip	87	1	Upright Wire
38	2	5/16" Cage Nut	88	1	Left Upright Spacer
39	2	Foot Rail Decal	89	2	Base Cap
40	1	Left Foot Rail	90	4	Base Pad
41	1	Latch Warning Decal	91	1	Right Upright Spacer
42	2	Platform Cushion	92	2	Caution Decal
43	2	Belt Guide	93	1	Incline Wire
44	1	Walking Platform	94	2	Base Pad Spacer
45	2	Frame Cap	95	1	Base
46	2	Frame Spacer	96	2	Wheel
47	1	Magnet	97	1	Incline Motor
48	1	Drive Roller/Pulley	98	1	Incline Motor Spacer
49	1	Walking Belt	99	1	Key/Clip
50	1	Left Speaker	100	3	Cable Tie

<b>Key No.</b>	<b>Qty.</b>	<b>Description</b>	<b>Key No.</b>	<b>Qty.</b>	<b>Description</b>
101	1	Console	105	2	Console Clamp
102	1	Console Frame	106	1	Console Base
103	1	Left Accessory Tray	*	–	User's Manual
104	1	Right Accessory Tray			

Note: Specifications are subject to change without notice. For information about ordering replacement parts, see the back cover of this manual. \*These parts are not illustrated.

# EXPLODED DRAWING A—Model No. PFTL66010.0

R0410A

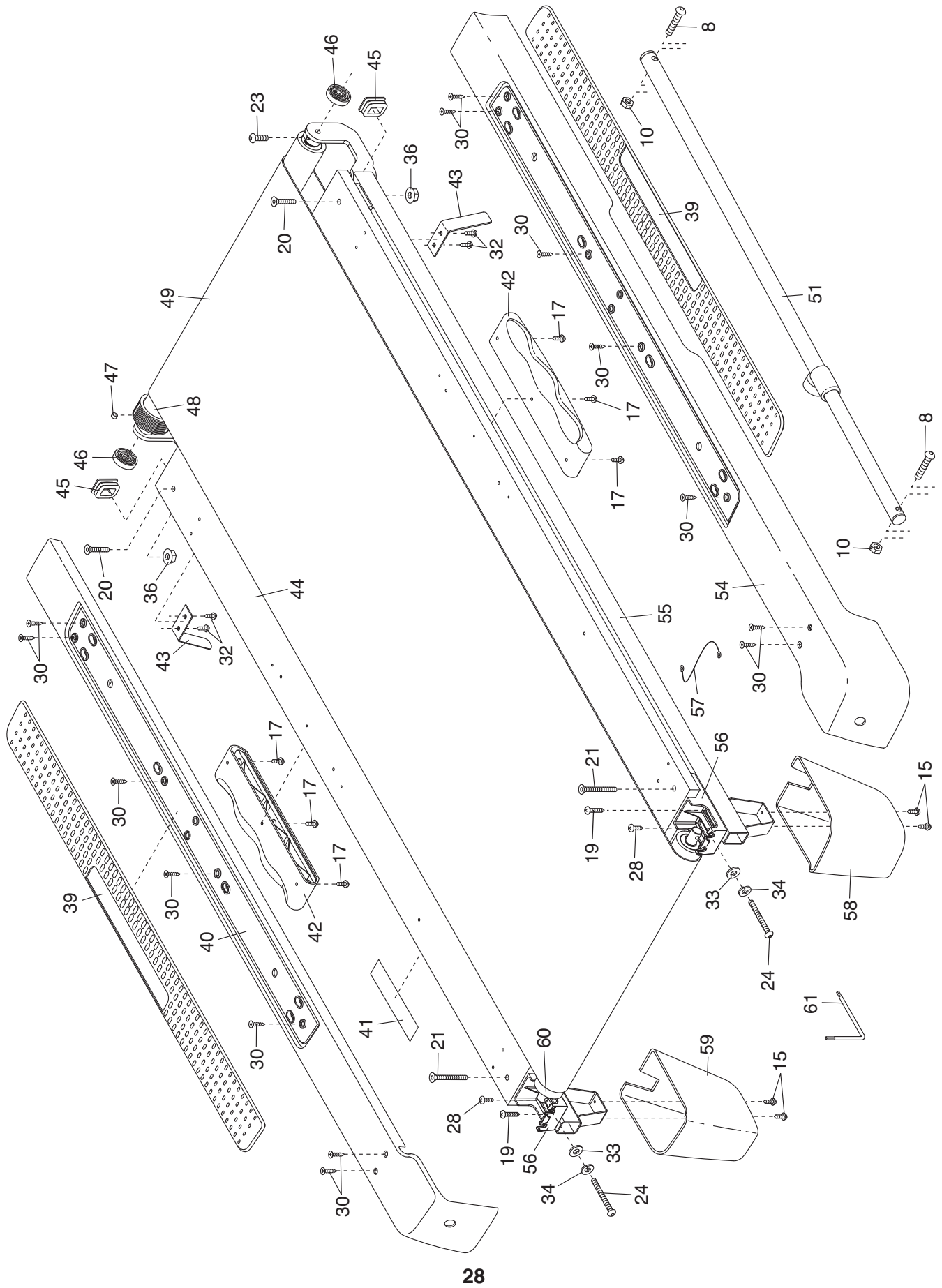

# EXPLODED DRAWING B—Model No. PFTL66010.0

R0410A

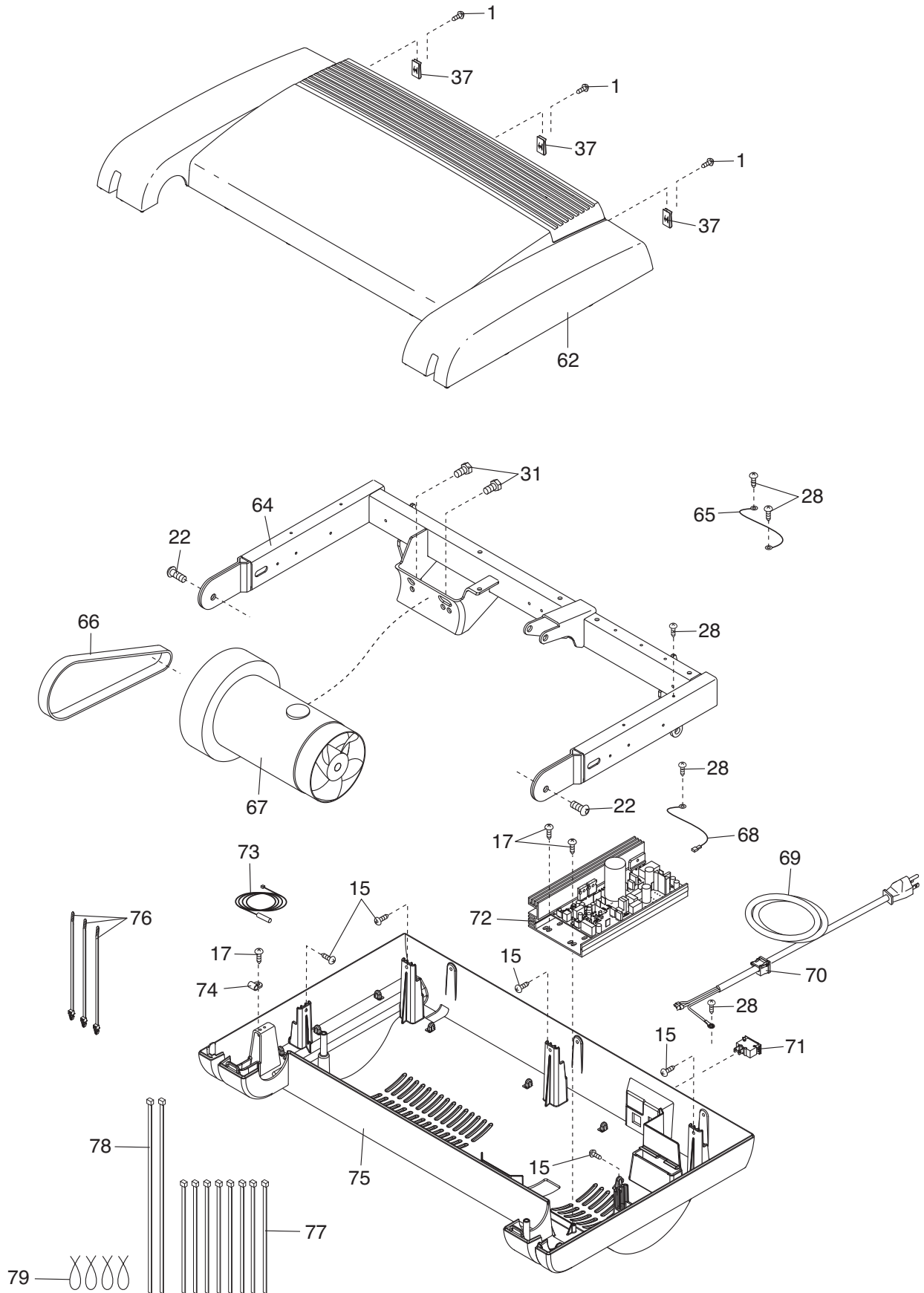

# EXPLODED DRAWING C—Model No. PFTL66010.0

R0410A

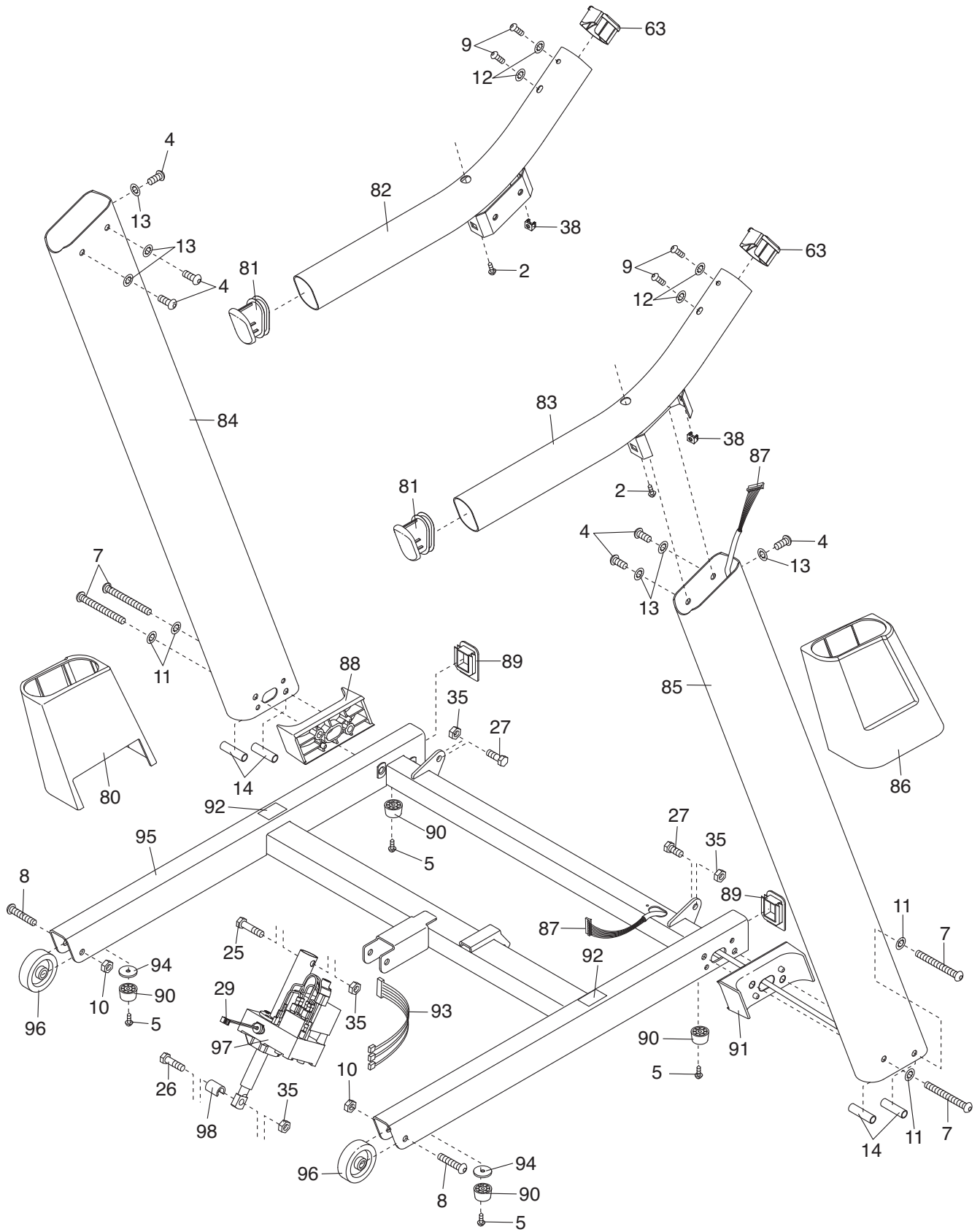

# EXPLODED DRAWING D—Model No. PFTL66010.0

R0410A

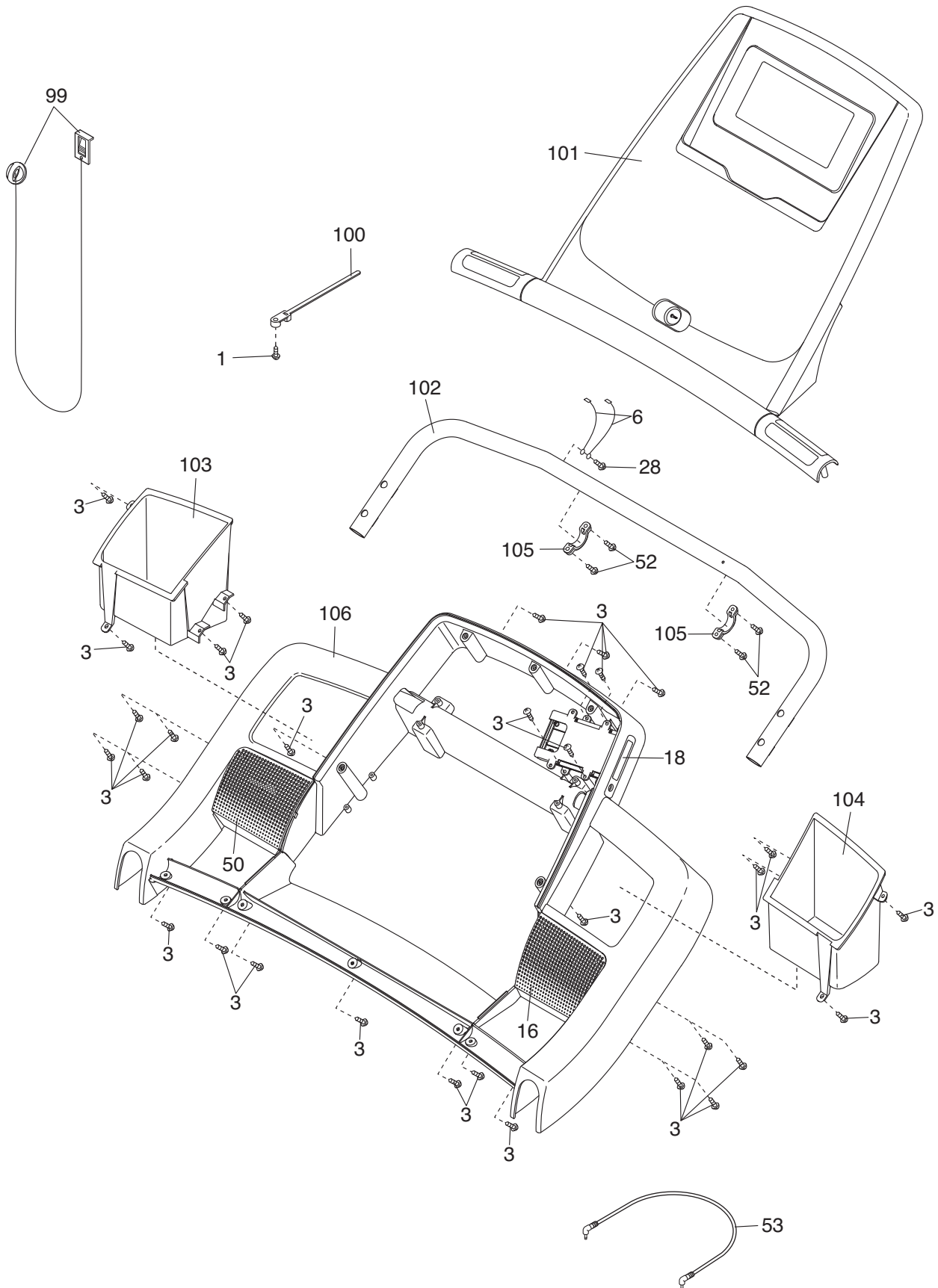

---

# ORDERING REPLACEMENT PARTS

To order replacement parts, please see the front cover of this manual. To help us assist you, be prepared to provide the following information when contacting us:

- the model number and serial number of the product (see the front cover of this manual)
- the name of the product (see the front cover of this manual)
- the key number and description of the replacement part(s) (see the PART LIST and the EXPLODED DRAWING near the end of this manual)

## LIMITED WARRANTY

**IMPORTANT: You must register this product within 30 days of the purchase date to avoid added fees for service needed under warranty. Go to [www.proformservice.com/registration](http://www.proformservice.com/registration).**

ICON Health & Fitness, Inc. (ICON) warrants this product to be free from defects in workmanship and material, under normal use and service conditions. The frame and drive motor are warranted for a life-time. Parts and labor are warranted for one (1) year from the date of purchase.

This warranty extends only to the original purchaser. ICON's obligation under this warranty is limited to repairing or replacing, at ICON's option, the product through one of its authorized service centers. All repairs for which warranty claims are made must be preauthorized by ICON. If the product is shipped to a service center, freight charges to and from the service center will be the customer's responsibility. For replacement parts shipped while the product is under warranty, the customer will be responsible for a minimal handling charge. For in-home service, the customer will be responsible for a minimal trip charge. This warranty does not extend to any damage to a product caused by or attributable to freight damage, abuse, misuse, improper or abnormal usage, or repairs not provided by an ICON authorized service center; to products used for commercial or rental purposes or as store display models; or to products transported or purchased outside the US. No other warranty beyond that specifically set forth above is authorized by ICON.

ICON is not responsible or liable for indirect, special, or consequential damages arising out of or in connection with the use or performance of the product; damages with respect to any economic loss, loss of property, loss of revenues or profits, loss of enjoyment or use, or costs of removal or installation; or other consequential damages of whatsoever nature. Some states do not allow the exclusion or limitation of incidental or consequential damages. Accordingly, the above limitation may not apply to you.

The warranty extended hereunder is in lieu of any and all other warranties, and any implied warranties of merchantability or fitness for a particular purpose are limited in their scope and duration to the terms set forth herein. Some states do not allow limitations on how long an implied warranty lasts. Accordingly, the above limitation may not apply to you.

This warranty gives you specific legal rights. You may also have other rights that vary from state to state.

**ICON Health & Fitness, Inc., 1500 S. 1000 W., Logan, UT 84321-9813**