

# PRO-FORM<sup>®</sup>

## 1210 RT

[www.proform.com](http://www.proform.com)

Model No. PFTL01411.0

Serial No. \_\_\_\_\_

Write the serial number in the space above for reference.

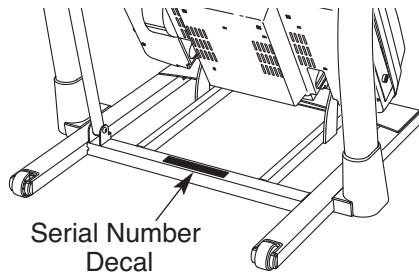

## USER'S MANUAL

### QUESTIONS?

If you have questions, or if parts are damaged or missing, **DO NOT CONTACT THE STORE**; please contact Customer Care.

**IMPORTANT:** Please register this product (see the limited warranty on the back cover of this manual) before contacting Customer Care.

CALL TOLL-FREE:

**1-888-533-1333**

Mon.–Fri. 6 a.m.–6 p.m. MT

Sat. 8 a.m.–4 p.m. MT

ON THE WEB:

[www.proformservice.com](http://www.proformservice.com)



### ⚠ CAUTION

Read all precautions and instructions in this manual before using this equipment. Save this manual for future reference.



# TABLE OF CONTENTS

WARNING DECAL PLACEMENT .....	.2
IMPORTANT PRECAUTIONS .....	.3
BEFORE YOU BEGIN .....	.5
ASSEMBLY .....	.6
OPERATION AND ADJUSTMENT .....	.14
HOW TO FOLD AND MOVE THE TREADMILL .....	.25
TROUBLESHOOTING .....	.26
EXERCISE GUIDELINES .....	.29
PART LIST .....	.30
EXPLODED DRAWING .....	.32
ORDERING REPLACEMENT PARTS .....	.Back Cover
LIMITED WARRANTY .....	.Back Cover

## WARNING DECAL PLACEMENT

This drawing shows the locations of the warning decals. **If a decal is missing or illegible, call the telephone number on the front cover of this manual and request a free replacement decal. Apply the decal in the location shown.** Note: The decals may not be shown at actual size.

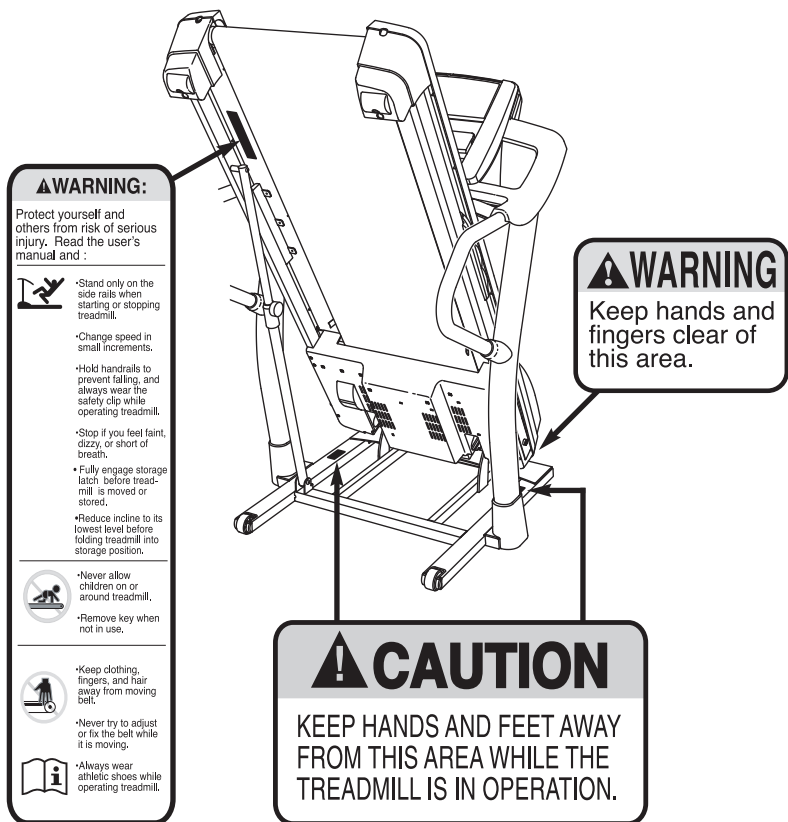

# IMPORTANT PRECAUTIONS

**⚠ WARNING:** To reduce the risk of serious injury, read all important precautions and instructions in this manual and all warnings on your treadmill before using your treadmill. ICON assumes no responsibility for personal injury or property damage sustained by or through the use of this product.

1. Before beginning any exercise program, consult your physician. This is especially important for persons over age 35 or persons with pre-existing health problems.
2. It is the responsibility of the owner to ensure that all users of this treadmill are adequately informed of all warnings and precautions.
3. Use the treadmill only as described.
4. Keep the treadmill indoors, away from moisture and dust. Do not put the treadmill in a garage or covered patio, or near water.
5. Place the treadmill on a level surface, with at least 8 ft. (2.4 m) of clearance behind it and 2 ft. (0.6 m) on each side. Do not place the treadmill on any surface that blocks air openings. To protect the floor or carpet from damage, place a mat under the treadmill.
6. Do not operate the treadmill where aerosol products are used or where oxygen is being administered.
7. Keep children under age 12 and pets away from the treadmill at all times.
8. The treadmill should be used only by persons weighing 350 lbs. (159 kg) or less.
9. Never allow more than one person on the treadmill at a time.
10. Wear appropriate exercise clothes while using the treadmill. Do not wear loose clothes that could become caught in the treadmill. Athletic support clothes are recommended for both men and women. *Always wear athletic shoes. Never use the treadmill with bare feet, wearing only stockings, or in sandals.*
11. When connecting the power cord (see page 14), plug the power cord into a surge suppressor (not included) and plug the surge suppressor into a grounded circuit capable of carrying 15 or more amps. No other appliance should be on the same circuit. Do not use an extension cord.
12. Use only a single-outlet surge suppressor that meets all of the specifications described on page 14. To purchase a surge suppressor, see your local PROFORM dealer or call the telephone number on the front cover of this manual and order part number 146148, or see your local electronics store.
13. Failure to use a properly-functioning surge suppressor could result in damage to the control system of the treadmill. If the control system is damaged, the walking belt may slow, accelerate, or stop unexpectedly, which may result in a fall and serious injury.
14. Keep the power cord and the surge suppressor away from heated surfaces.
15. Never move the walking belt while the power is turned off. Do not operate the treadmill if the power cord or plug is damaged, or if the treadmill is not working properly. (See TROUBLESHOOTING on page 26 if the treadmill is not working properly.)
16. Read, understand, and test the emergency stop procedure before using the treadmill (see HOW TO TURN ON THE POWER on page 16).
17. Never start the treadmill while you are standing on the walking belt. Always hold the handrails while using the treadmill.
18. The treadmill is capable of high speeds. Adjust the speed in small increments to avoid sudden jumps in speed.
19. The heart rate monitor is not a medical device. Various factors, including the user's movement, may affect the accuracy of heart rate readings. The heart rate monitor is intended only as an exercise aid in determining heart rate trends in general.

20. Never leave the treadmill unattended while it is running. Always remove the key, unplug the power cord, and press the power switch into the off position when the treadmill is not in use. (See the drawing on page 5 for the location of the power switch.)
21. Do not attempt to raise, lower, or move the treadmill until it is properly assembled. (See ASSEMBLY on page 6, and HOW TO FOLD AND MOVE THE TREADMILL on page 25.) You must be able to safely lift 45 lbs. (20 kg) to raise, lower, or move the treadmill.
22. When folding or moving the treadmill, make sure that the storage latch is holding the frame securely in the storage position.
23. Never insert any object into any opening on the treadmill.
24. Inspect and properly tighten all parts of the treadmill regularly.
25. **DANGER:** Always unplug the power cord immediately after use, before cleaning the treadmill, and before performing the maintenance and adjustment procedures described in this manual. Never remove the motor hood unless instructed to do so by an authorized service representative. Servicing other than the procedures in this manual should be performed by an authorized service representative only.
26. This treadmill is intended for home use only. Do not use this treadmill in a commercial, rental, or institutional setting.
27. Over exercising may result in serious injury or death. If you feel faint or if you experience pain while exercising, stop immediately and cool down.

**SAVE THESE INSTRUCTIONS**

# BEFORE YOU BEGIN

Thank you for selecting the revolutionary PROFORM® 1210 RT treadmill. The 1210 RT treadmill offers an impressive selection of features designed to make your workouts at home more enjoyable and effective. And when you're not exercising, the unique treadmill can be folded up, requiring less than half the floor space of other treadmills.

**For your benefit, read this manual carefully before using the treadmill.** If you have questions after read-



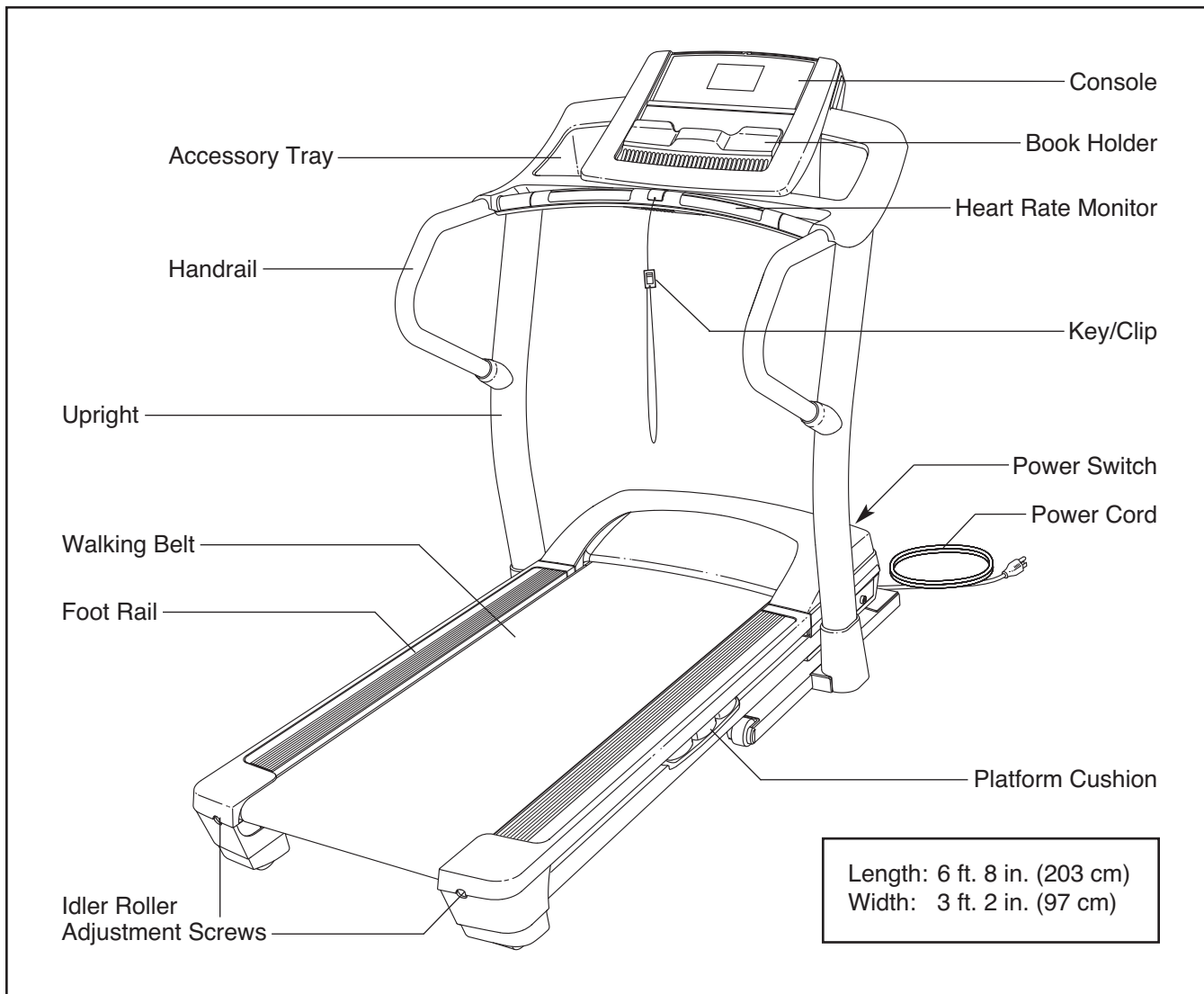

ing this manual, please see the front cover of this manual. To help us assist you, please note the product model number and serial number before contacting us. The model number and the location of the serial number decal are shown on the front cover of this manual.

Before reading further, please review the drawing below and familiarize yourself with the labeled parts.



# ASSEMBLY

**Assembly requires two persons.** Set the treadmill in a cleared area and remove all packing materials. **Do not dispose of the packing materials until assembly is completed.** Note: The underside of the treadmill walking belt is coated with high-performance lubricant. During shipping, some lubricant may be transferred to the top of the walking belt or the shipping carton. This is normal and does not affect treadmill performance. If there is lubricant on top of the walking belt, simply wipe off the lubricant with a soft cloth and a mild, non-abrasive cleaner.

**Assembly requires the included hex keys  and your own Phillips screwdriver , adjustable wrench , needlenose pliers , and scissors .**

Use the drawings below to identify the assembly hardware. The number in parentheses below each drawing is the key number of the part, from the PART LIST near the end of this manual. The number after the parentheses is the quantity needed for assembly. **Note: If a part is not in the hardware kit, check to see if it is preattached to one of the parts to be assembled. To avoid damaging parts, do not use power tools for assembly. Extra hardware may be included.**

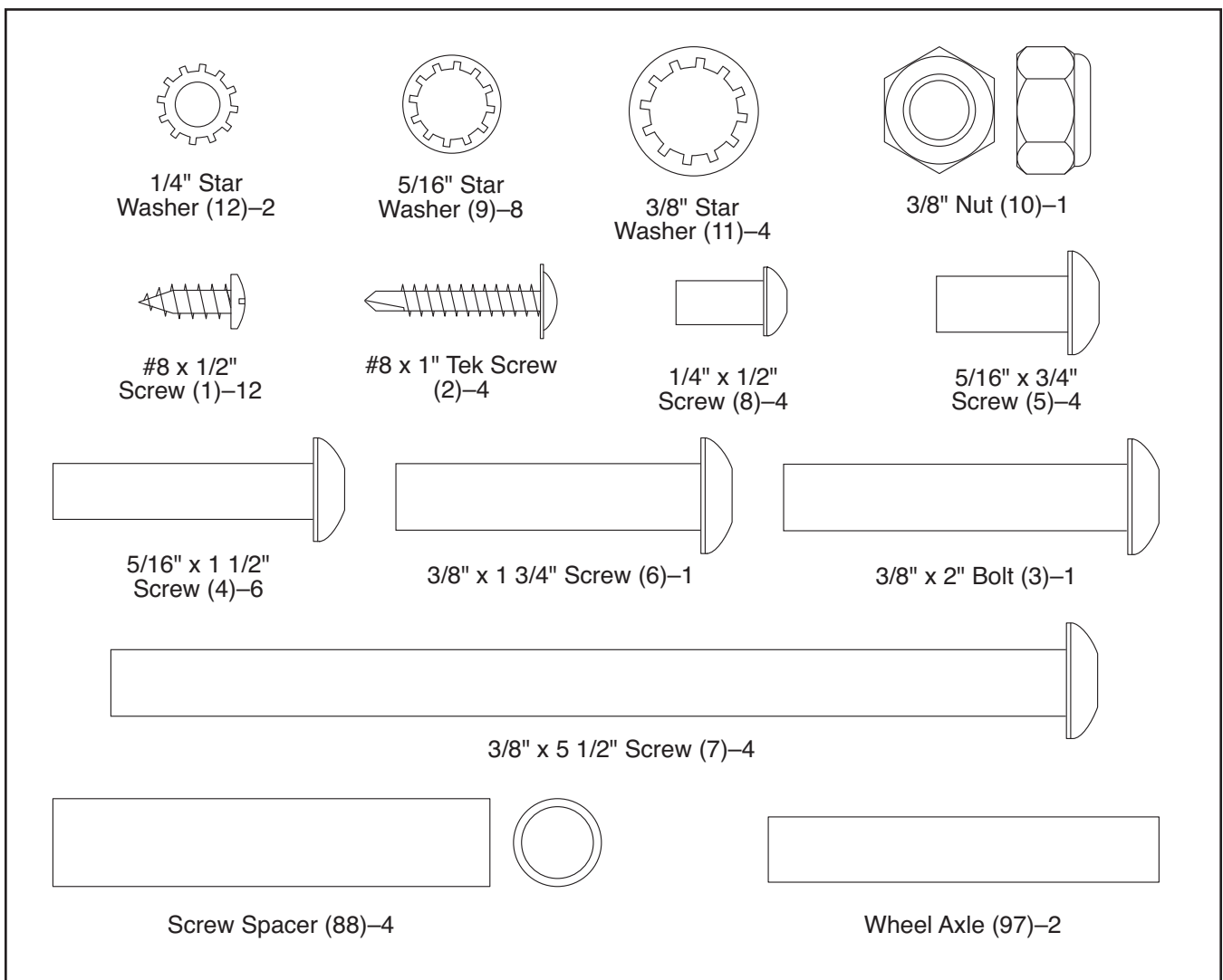

1. **Make sure that the power cord is unplugged.**

With the help of a second person, carefully tip the treadmill onto its left side. Partially fold the Frame (55) so that the treadmill is more stable; **do not fully fold the Frame yet.**

Locate the Upright Wire (85), which is bundled at the back of the Base (94). Remove the packaging from the Upright Wire. Next, insert the Upright Wire into the Base, and pull it out of the indicated hole. If necessary, use the plastic tie to pull the Upright Wire out of the hole.

Next, hold a Wheel (95) inside of a Wheel Housing (96). Insert a Wheel Axle (97) into the Wheel, and press the Wheel Housing into the Base (94). **Make sure that the tab on the Wheel Housing is in the position shown.**

**Attach the other Wheel (95) in the same way.**

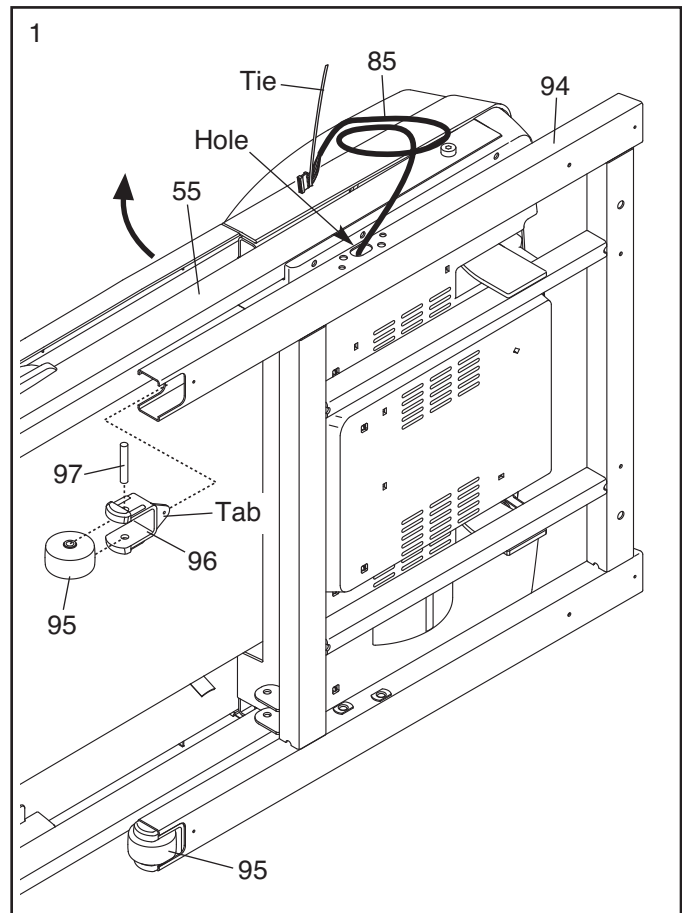

2. Attach the four Base Feet (92) to the Base (94) in the locations shown with four #8 x 1" Tek Screws (2).

**See the inset drawing.** Cut the plastic tie near the Upright Wire (85).

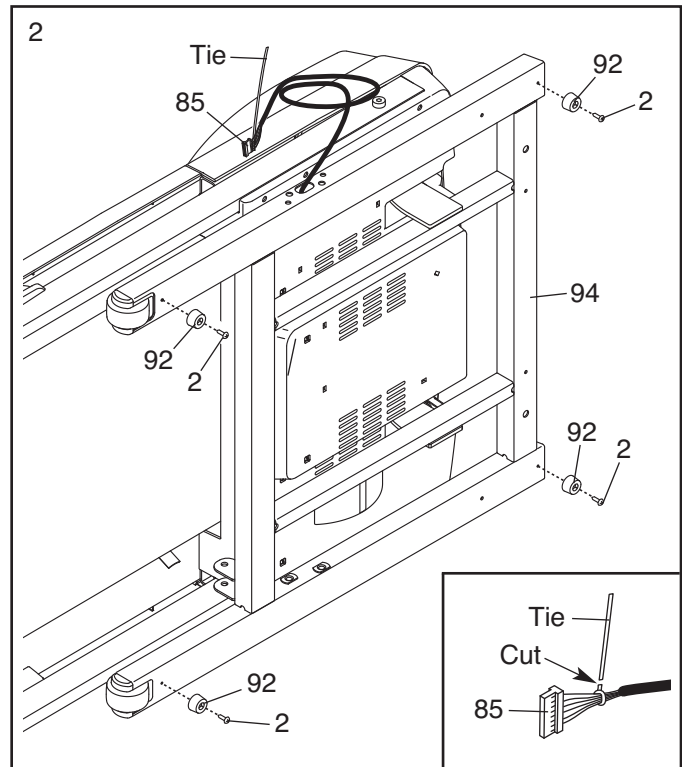

3. Identify the Right Upright Spacer (91), which is marked with a "Right" sticker.

Align the oval hole in the Right Upright Spacer (91) with the oval hole in the Base (94). If the holes do not line up, turn the Right Upright Spacer and try again.

Insert the Upright Wire (85) through the Right Upright Spacer (91). Set the Right Upright Spacer on the Base (94).

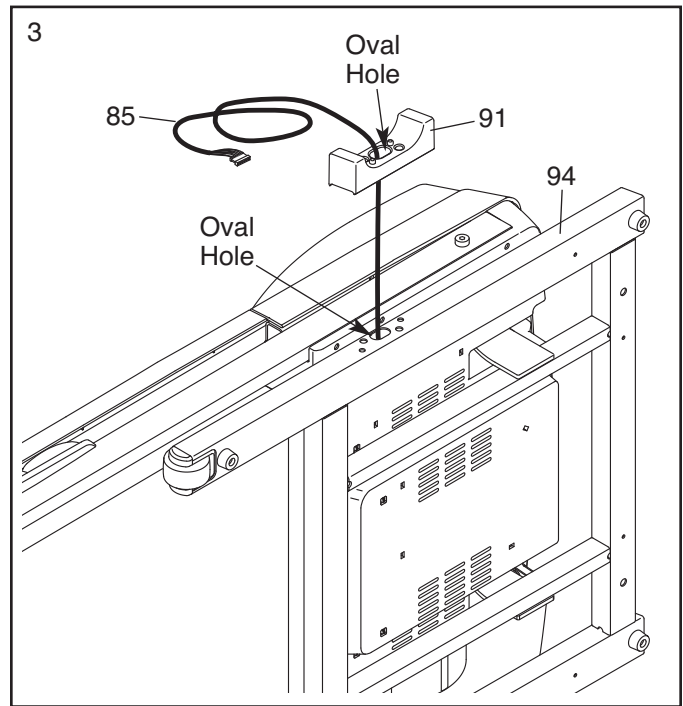

4. Identify the Right Upright (83), which is marked with a "Right" sticker. Orient the Right Upright Cover (86) as shown. Slide the Right Upright Cover onto the lower end of the Right Upright.

Have a second person hold the Right Upright (83) near the Base (94). **See the inset drawing.** Tie the wire tie in the Right Upright securely around the end of the Upright Wire (85). Then, pull the other end of the wire tie until the Upright Wire is routed through the Right Upright.

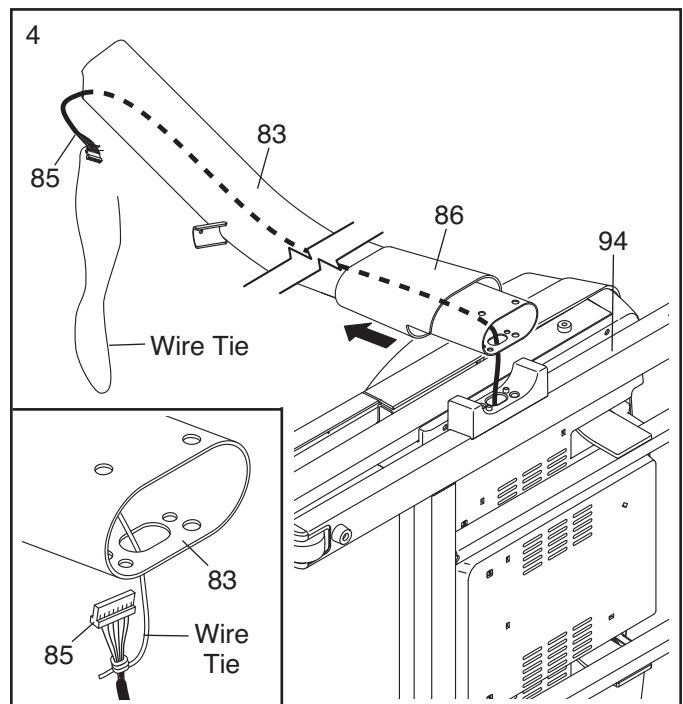



5. Hold a Screw Spacer (88) inside the lower end of the Right Upright (83). Insert a 3/8" x 5 1/2" Screw (7) with a 3/8" Star Washer (11) into the Right Upright and the Screw Spacer. **Repeat this step with a second Screw Spacer (88), 3/8" x 5 1/2" Screw (7), and 3/8" Star Washer (11).**

Hold the Right Upright (83) against the Right Upright Spacer (91). **Be careful not to pinch the Upright Wire (85) or the ground wire.** Tighten the 3/8" x 5 1/2" Screws (7) until the heads of the Screws touch the Upright; **do not fully tighten the Screws yet.**

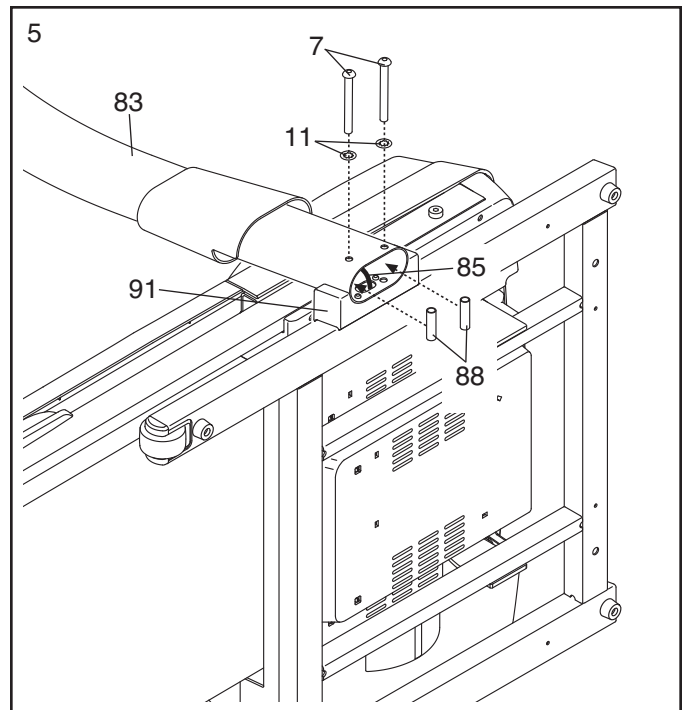

6. With the help of a second person, carefully tip the treadmill onto its right side. Partially fold the Frame (55) so that the treadmill is more stable; **do not fully fold the Frame yet.**

Slide the Left Upright Cover (87) onto the Left Upright (82).

Set the Left Upright Spacer (90) on the Base (94).

Hold a Screw Spacer (88) inside the lower end of the Left Upright (82). Insert a 3/8" x 5 1/2" Screw (7) with a 3/8" Star Washer (11) into the Left Upright and the Screw Spacer. **Repeat this step with a second Screw Spacer (88), 3/8" x 5 1/2" Screw (7), and 3/8" Star Washer (11).**

Hold the Left Upright (82) against the Left Upright Spacer (90). Tighten the 3/8" x 5 1/2" Screws (7) until the heads of the Screws touch the Upright; **do not fully tighten the Screws yet.**

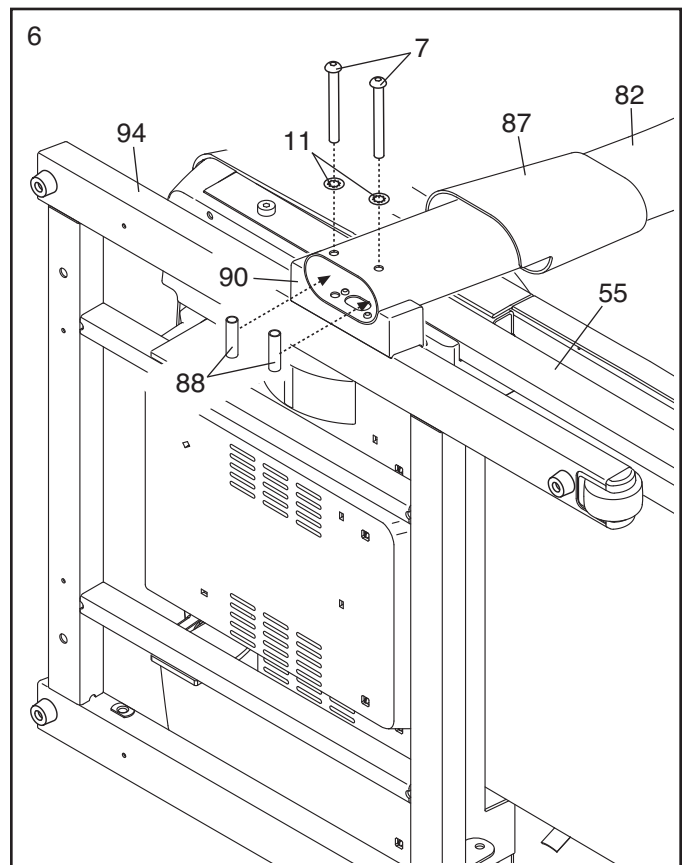

7. Attach the Base Cover (84) to the Base (94) with four #8 x 1/2" Screws (1). **Be careful not to overtighten the Screws.**

With the help of a second person, tip the treadmill so that the Base (94) is flat on the floor.

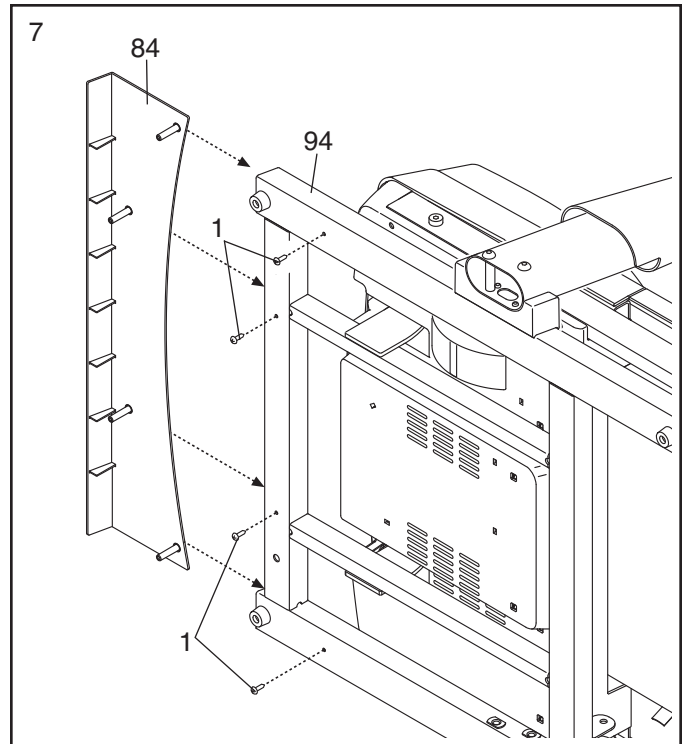

8. Set the console assembly face down on a soft surface to avoid scratching the console.

Identify the Right Handrail (79). Hold the Right Handrail near the console assembly. Route the console wire through the large holes in the top and bottom of the Right Handrail.

Set the Right Handrail (79) on the Console Frame (81). Start a 1/4" x 1/2" Screw (8) with a 1/4" Star Washer (12) into the Right Handrail. Then, start two 5/16" x 1 1/2" Screws (4) with two 5/16" Star Washers (9) into the Right Handrail. **Make sure that the console wire is not pinched. Do not tighten the three Screws yet.**

Attach the Left Handrail (not shown) as described above. **Note: There is not a wire on the left side.**

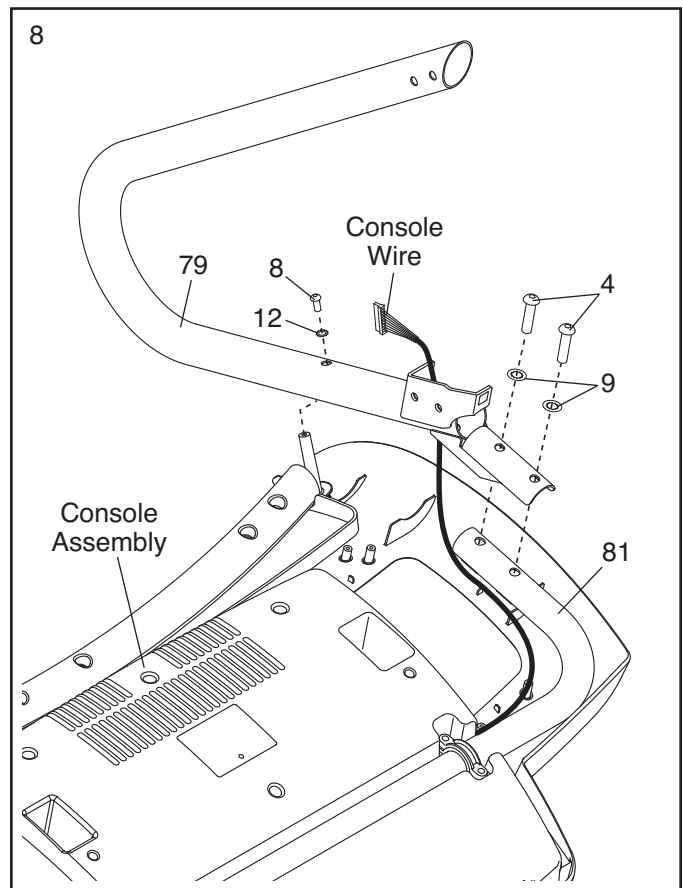

- With the help of a second person, grip the sides of the console assembly and hold it near the Right Upright (83) and the Left Upright (not shown). **Do not lift the console assembly by the Right Handrail (79) or the Left Handrail (not shown).**

Connect the Upright Wire (85) to the console wire. **See the inset drawing. The connectors should slide together easily and snap into place.** If they do not, turn one connector and try again. **IF THE CONNECTORS ARE NOT CONNECTED PROPERLY, THE CONSOLE MAY BE DAMAGED WHEN YOU TURN ON THE POWER.** Then, remove the wire tie from the Upright Wire.

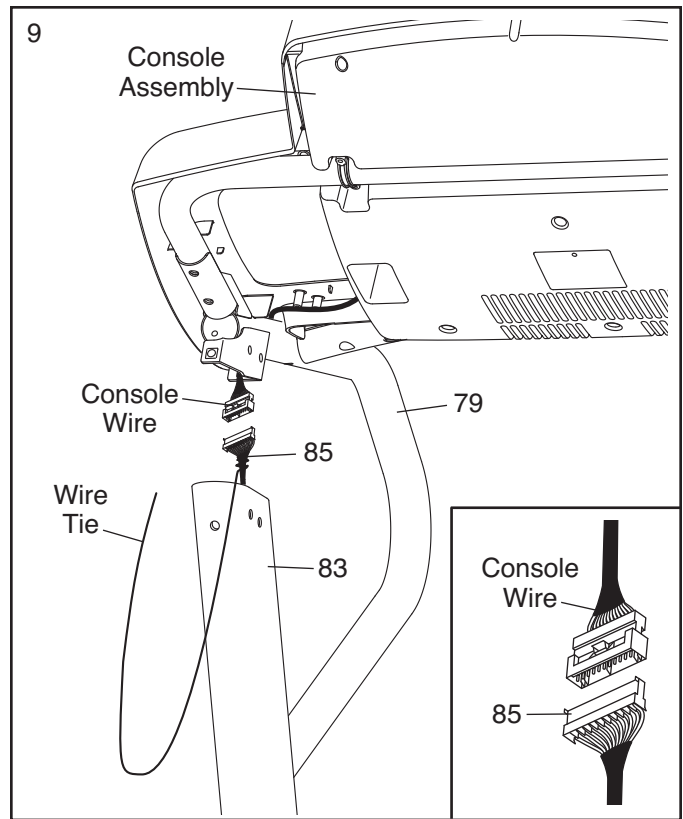

- Slide a Handrail Cover (77) onto the lower end of each Handrail (78, 79).

Set the console assembly on the Left and Right Uprights (82, 83). At the same time, slide the lower ends of the Handrails (78, 79) over the brackets on the Uprights. **Be careful not to pinch any wires.** Insert the excess wire into the Right Upright.

Start four 5/16" x 3/4" Screws (5) with four 5/16" Star Washers (9) into the Uprights (82, 83). Then, start two 5/16" x 1 1/2" Screws (4) into the Uprights. **Do not tighten the Screws yet.**

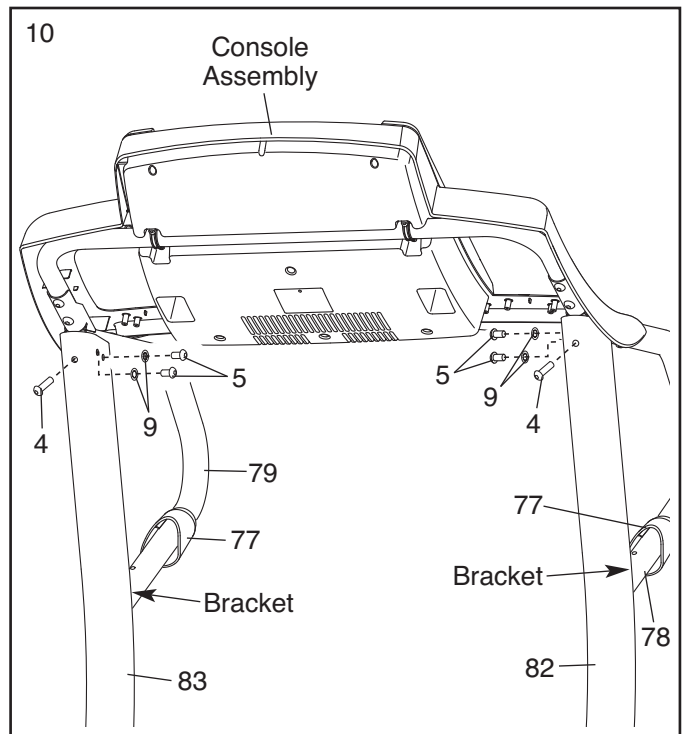

11. Start two 1/4" x 1/2" Screws (8) into the lower ends of both Handrails (78, 79). **Tighten all fourteen Screws (4, 5, 8).**

Slide the Handrail Covers (77) against the Uprights (82, 83).

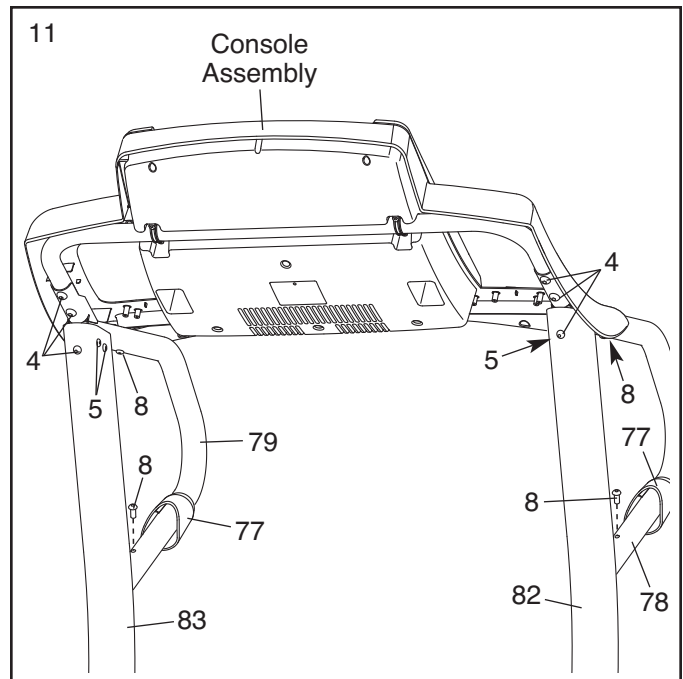

12. **See steps 5 and 6.** Tighten the four 3/8" x 5 1/2" Screws (7).

Attach the Left Accessory Tray (101) and the Right Accessory Tray (104) to the console assembly with eight #8 x 1/2" Screws (1).

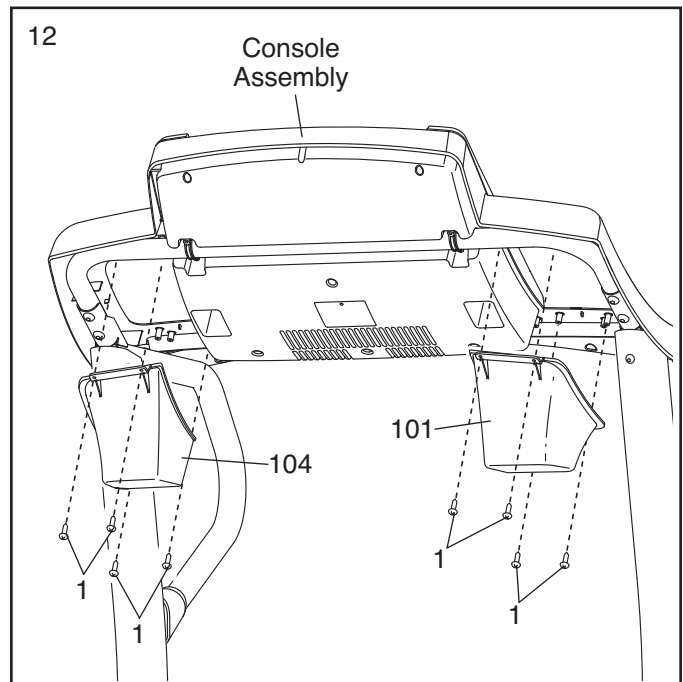

13. Turn on the power (see page 16). Next, adjust the incline to the lowest position (see step 4 on page 17). **Then, remove the key from the console, press the power switch into the off position, and unplug the power cord.**

Raise the Frame (55) to the position shown. **Have a second person hold the Frame until step 14 is completed.**

Orient the Storage Latch (51) so that the large barrel and the latch knob are in the positions shown.

Remove the tie from the lower end of the Storage Latch (51). Keep the holes in the latch cap aligned with the holes in the Storage Latch. Attach the Storage Latch to the Base (94) with a 3/8" x 2" Bolt (3) and a 3/8" Nut (10).

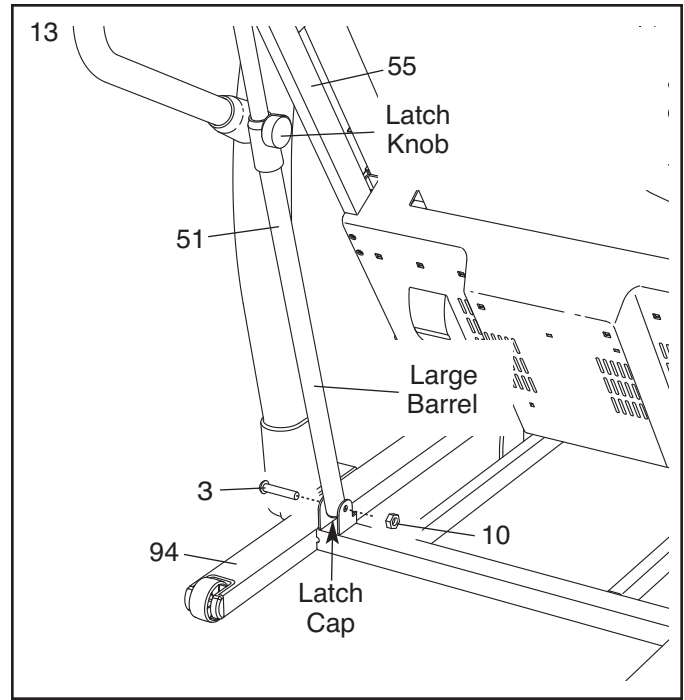

14. Remove the tie from the upper end of the Storage Latch (51). Attach the upper end of the Storage Latch to the Frame (55) with a 3/8" x 1 3/4" Screw (6).

Lower the Frame (55) (see HOW TO LOWER THE TREADMILL FOR USE on page 25).

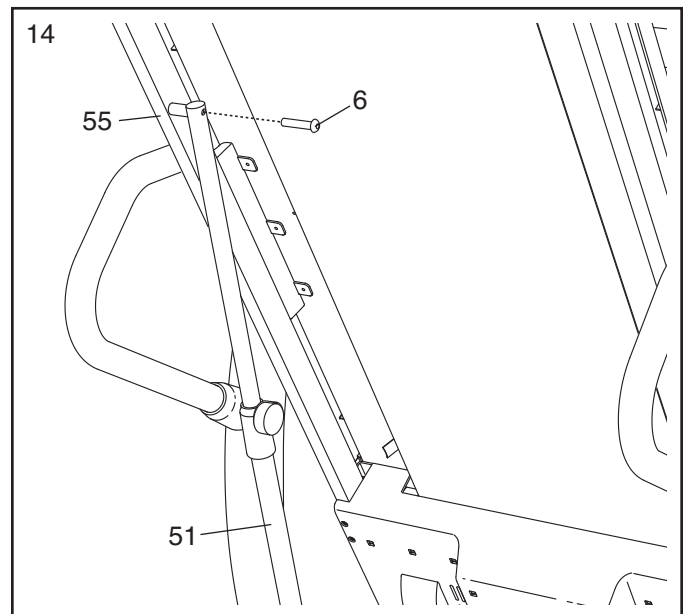

15. **Make sure that all parts are properly tightened before you use the treadmill.** If there are sheets of plastic on the treadmill decals, remove the plastic. To protect the floor or carpet, place a mat under the treadmill.  
Note: Extra hardware may be included. Keep the included hex keys in a secure place; one of the hex keys is used to adjust the walking belt (see pages 27 and 28).

# OPERATION AND ADJUSTMENT

## HOW TO PLUG IN THE POWER CORD

**⚠ DANGER:** Improper connection of the equipment-grounding conductor increases the risk of electric shock. Check with a qualified electrician or serviceman if you are unsure whether the product is properly grounded. Do not modify the plug—if it will not fit the outlet, have a proper outlet installed by a qualified electrician.

Your treadmill, like other electronic equipment, can be damaged by sudden voltage changes in your home's power. **To decrease the risk of damaging your treadmill, always use a surge suppressor with your treadmill (see drawing 1 at the right). To purchase a surge suppressor, see precaution 12 on page 3.**

**Use only a single-outlet surge suppressor that is UL 1449 listed as a transient voltage surge suppressor (TVSS). The surge suppressor must have a UL suppressed voltage rating of 400 volts or less and a minimum surge dissipation of 450 joules. The surge suppressor must be electrically rated for 120 volts AC and 15 amps. There must be a monitoring light on the surge suppressor to indicate whether it is functioning properly. Failure to use a properly-functioning surge suppressor could damage the control system of the treadmill (see precaution 13 on page 3).**

**This product must be grounded.** If it should malfunction or break down, grounding provides a path of least resistance for electric current to reduce the risk of electric shock. This product's power cord has an equipment-grounding conductor and a grounding plug. **Plug the power cord into a surge suppressor, and plug the surge suppressor into an appropriate outlet that is properly installed and grounded in accordance with all local codes and ordinances. IMPORTANT: The treadmill is not compatible with GFCI-equipped outlets and may not be compatible with AFCI-equipped outlets.**

This product is for use on a nominal 120-volt circuit (see drawing 1). A temporary adapter may be used to connect the surge suppressor to a 2-pole receptacle if a properly-grounded outlet is not available (see drawing 2).

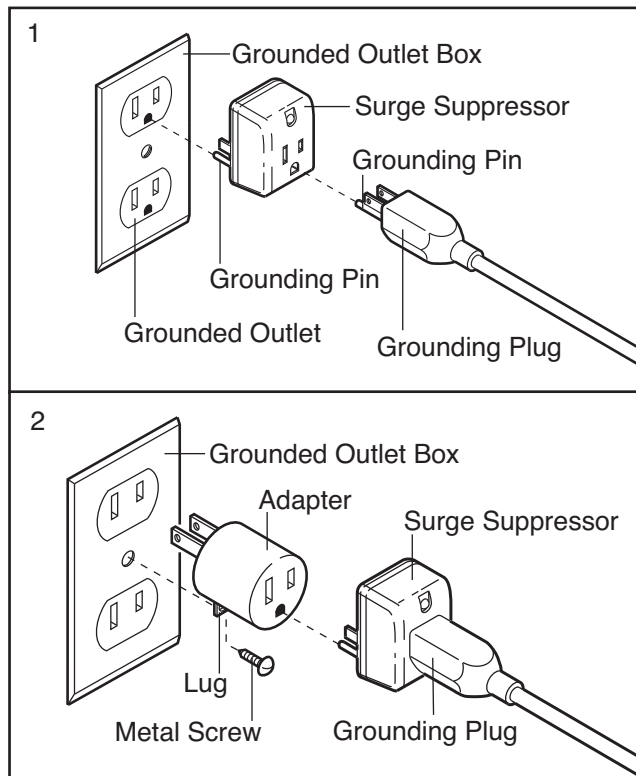

The temporary adapter should be used only until a properly-grounded outlet (see drawing 1) can be installed by a qualified electrician.

The green-colored rigid ear, lug, or the like extending from the adapter must be connected to a permanent ground such as a properly-grounded outlet box cover. The adapter must be held in place by a metal screw. **Some 2-pole receptacle outlet box covers are not grounded. Contact a qualified electrician to determine if the outlet box cover is grounded before using an adapter.**



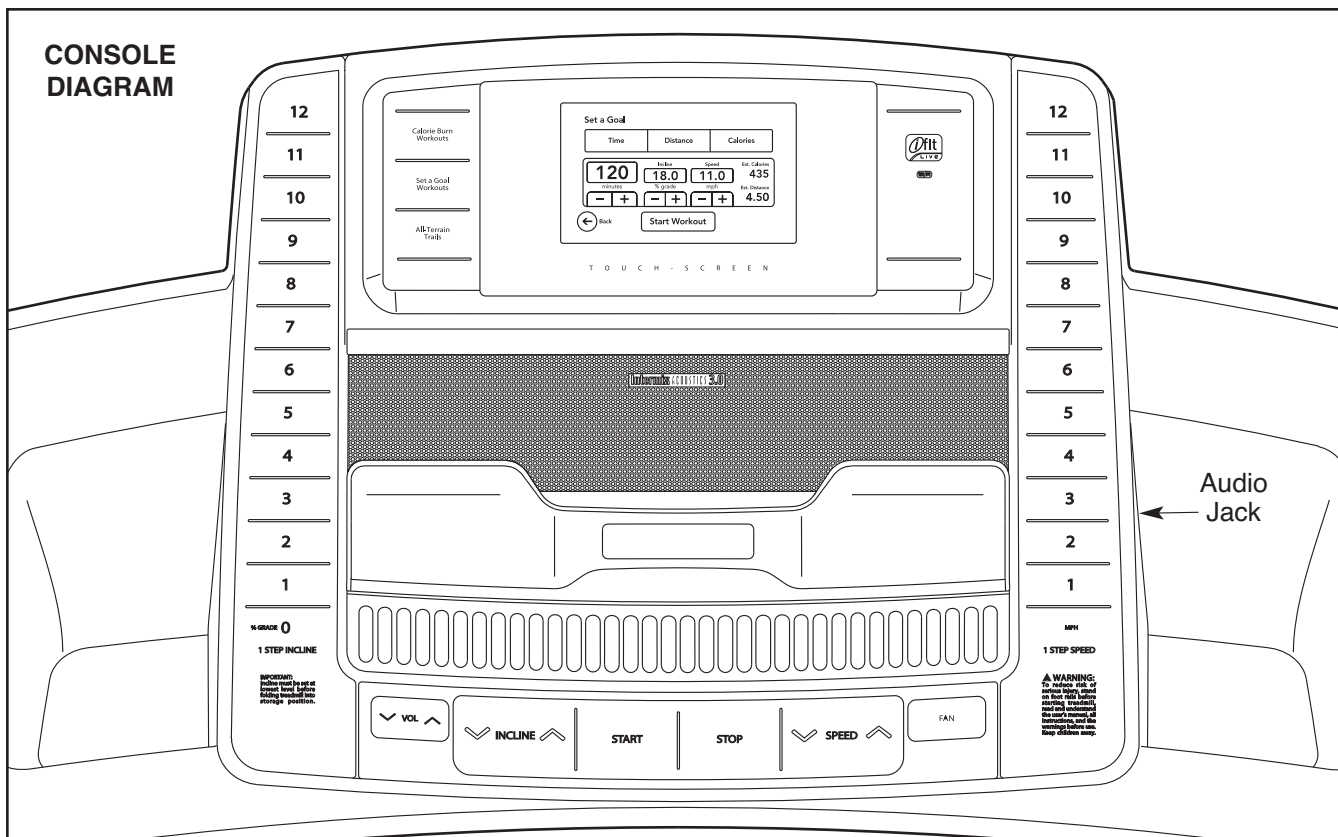

## FEATURES OF THE CONSOLE

The treadmill console offers an impressive array of features designed to make your workouts more effective and enjoyable. When the manual mode of the console is selected, you can change the speed and incline of the treadmill with the touch of a button. As you exercise, the console will display continuous exercise feedback. You can even measure your heart rate using the handgrip heart rate monitor.

The console also offers thirty preset workouts—twenty calorie burn workouts and ten all-terrain trails workouts. Each workout automatically controls the speed and incline of the treadmill as it guides you through an effective exercise session. In addition, you can set a time, distance, or calorie goal.

The console also features an iFit Live mode that enables the treadmill to communicate with your wireless network. With the iFit Live mode, you can download personalized workouts, create your own workouts, track your workout results, and access many other features. **See [www.iFit.com](http://www.iFit.com) for complete information.**

You can also listen to your favorite workout music or audio books with the console's premium stereo sound system while you get in shape.

**To turn on the power**, see page 16. **To use the manual mode**, see page 16. **To use a set-a-goal workout**, see page 18. **To use a calorie burn workout or an all-terrain trails workout**, see page 19. **To use the iFit Live mode**, see page 21. **To use the stereo sound system**, see page 21. **To use the settings mode**, see page 22. **To use the maintenance mode**, see page 24.

**IMPORTANT:** If there is a sheet of plastic on the face of the console, remove the plastic. To prevent damage to the walking platform, wear clean athletic shoes while using the treadmill. The first time the treadmill is used, observe the alignment of the walking belt, and center the walking belt if necessary (see page 28).

## HOW TO TURN ON THE POWER

**IMPORTANT:** If the treadmill has been exposed to cold temperatures, allow it to warm to room temperature before turning on the power. If you do not do this, you may damage the console displays or other electrical components.

Plug in the power cord (see page 14). Next, locate the reset/off circuit breaker on the treadmill frame near the power cord. Make sure that the circuit breaker is in the reset position.

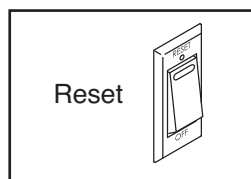

**IMPORTANT:** The console features a display demo mode, designed to be used if the treadmill is displayed in a store. If the demo mode is turned on, the displays will light a few seconds after you plug in the power cord and switch the reset/off circuit breaker to the reset position, before you insert the key. To turn off the demo mode, see step 4 on page 23.

Next, stand on the walking platform of the treadmill. Locate the clip attached to the key (see the drawing at the right), and slide the clip securely onto the waistband of your clothes.

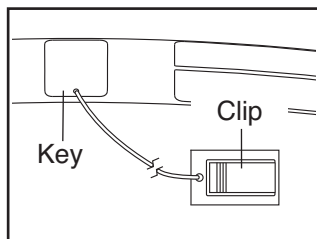

Then, insert the key into the console. After several seconds, the displays will light. **IMPORTANT:** In an emergency, the key can be pulled from the console, causing the walking belt to slow to a stop. Test the clip by carefully taking a few steps backward; if the key is not pulled from the console, adjust the position of the clip.

Before using the treadmill, please check for firmware updates (see step 7 on page 24).

Note: The console may be able to display speed and distance in either miles or kilometers. To find which unit of measurement is selected, see step 5 on page 23. For simplicity, all instructions in this manual refer to miles.

## HOW TO USE THE MANUAL MODE

### 1. Insert the key into the console.

See HOW TO TURN ON THE POWER at the left. If necessary, press the Incline buttons to adjust the incline level to 0 percent. **Note: It may take a minute for the console to be ready for use.**

Note: The first time you turn on the console, the incline may calibrate automatically. The frame will move upward and downward. If the incline does not calibrate, please see step 3 on page 24 and calibrate the incline manually.

### 2. Select the start menu.

Each time the key is inserted, the start menu will appear. If you have selected a workout or the iFit Live mode, press the iFit Menu button in the upper right corner of the screen. Next, press the End Workout button, and then press the Done button to return to the start menu.

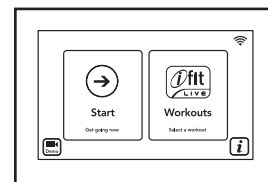

If the iFit login screen appears, press the Main Menu button and then press the Back button to return to the start menu.

Note: A Demo button may appear in the lower left corner of the screen. If you press the Demo button, the treadmill will run a demo workout.

### 3. Start the walking belt and adjust the speed.

To start the walking belt, press the Start button on the screen or the Start button on the console. The walking belt will begin to move at 1 mph. As you exercise, change the speed of the walking belt as desired by pressing the Speed increase and decrease buttons. Each time you press one of the buttons, the speed setting will change by 0.1 mph; if you hold down the button, the speed setting will change in increments of 0.5 mph.



If you press one of the numbered speed buttons, the walking belt will gradually change speed until it reaches the selected speed setting. To select a speed setting that includes a decimal—such as 3.5 mph—press two numbered buttons in succession. For example, to select a speed setting of 3.5 mph, press the 3 button and then immediately press the 5 button.

To stop the walking belt, press the Stop button. To restart the walking belt, press the Start button.

#### 4. Change the incline of the treadmill as desired.

To change the incline of the treadmill, press the Incline increase and decrease buttons or one of the Incline buttons numbered 0 to 12. Each time you press one of the buttons, the incline will gradually change until it reaches the selected incline setting.

#### 5. Monitor your progress.

The console offers several display modes. The display mode that you select will determine which workout information is shown. To select the desired display mode, repeatedly press the Display increase or decrease button on the screen.

As you walk or run on the treadmill, the screen can show the following workout information:

- The elapsed time
- The approximate number of calories you have burned
- The distance that you have walked or run
- The incline level of the treadmill
- The speed of the walking belt
- A track representing 1/4 mile (400 meters)

- The time to complete one lap at the current speed setting
- Your current lap number
- The time remaining
- The approximate number of calories burned per hour
- The number of vertical feet you have climbed
- Your pace in minutes per mile
- Your heart rate (see step 6 on page 18)

The displays at the top of the screen can show two pieces of information. Press each display until the display shows the desired information. Note: The manual mode does not have a time remaining countdown.

If desired, adjust the volume level by pressing the Volume increase and decrease buttons on the console.

To reset the console, press the iFit Menu button in the upper right corner of the screen. To pause the workout, press the Pause button. To continue the workout, press the Resume button or the Start button. To end the workout and select a new workout, press the New Workout button. To end the workout, press the End Workout button.

Note: The small wireless symbol in the upper right corner of the screen will show your wireless connection status. If the symbol is yellow, your treadmill is connected to your wireless network. If the symbol is green, your treadmill is connected to your wireless network and you have logged in to [www.iFit.com](http://www.iFit.com). If the symbol does not appear, your treadmill is not connected to your wireless network.



## 6. Measure your heart rate if desired.

Before using the handgrip heart rate monitor, remove the sheets of plastic from the metal contacts, if necessary. In addition, make sure that your hands are clean.

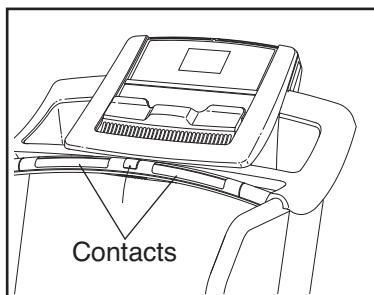

To measure your heart rate, **stand on the walking platform** and hold the metal contacts on the handrails for approximately ten seconds—**avoid moving your hands**. When your pulse is detected, your heart rate will be shown. **For the most accurate heart rate reading, continue to hold the contacts for about 15 seconds.**

## 7. Turn on the fan if desired.

The fan features three speed settings. Press the Fan button repeatedly to select a fan speed or to turn off the fan.

## 8. When you are finished exercising, remove the key from the console.

Step onto the foot rails and press the Stop button repeatedly until a workout summary appears on the screen. After you view the workout summary, press the Done button. Then, remove the key from the console and put it in a secure place.

When you are finished using the treadmill, switch the reset/off circuit breaker to the off position and unplug the power cord. **IMPORTANT: If you do not do this, the treadmill's electrical components may wear prematurely.**

## HOW TO USE A SET-A-GOAL WORKOUT

### 1. Insert the key into the console.

See step 1 on page 16.

### 2. Select the start menu.

See step 2 on page 16.

### 3. Select a set-a-goal workout.

To select a set-a-goal workout, first press the Workouts button on the screen. Then, press the Set a Goal button. You can also press the Set a Goal Workouts button on the console.

To set a time, distance, or calorie goal, press the Time, Distance, or Calories button. Then, press the increase and decrease buttons on the screen to select a time, distance, or calorie goal and to select the speed and incline for the workout. The screen will show the duration and distance of the workout, and the approximate number of calories you will burn during the workout.

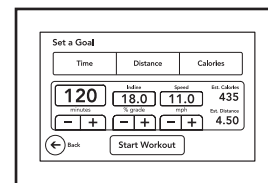

### 4. Start the workout.

Press the Start Workout button to start the workout. A moment after you press the button, the walking belt will begin to move. Hold the handrails and begin walking.

The workout will function in the same way as the manual mode (see pages 16 to 18).

The workout will continue until you reach the goal that you set. The walking belt will then slow to a stop, and a workout summary will appear on the screen. After you view the workout summary, press the Done button.

**5. Monitor your progress.**

See step 5 on page 17. The screen can also show your goal and a status bar showing your progress toward your goal.

**6. Measure your heart rate if desired.**

See step 6 on page 18.

**7. Turn on the fan if desired.**

See step 7 on page 18.

**8. When you are finished exercising, remove the key from the console.**

See step 8 on page 18.

**HOW TO USE A CALORIE BURN WORKOUT OR AN ALL-TERRAIN TRAILS WORKOUT**

**1. Insert the key into the console.**

See step 1 on page 16.

**2. Select the start menu.**

See step 2 on page 16.

**3. Select a calorie burn workout or an all-terrain trails workout.**

To select a calorie burn workout or an all-terrain trails workout, first press the Workouts button on the screen. Then, press the Calorie Burn button or the All-Terrain Trails button. You can also press the Calorie Burn Workouts button or the All-Terrain Trails button on the console.

**To select a calorie burn workout,** select the desired difficulty level. Then, select the desired workout. The screen will show the approximate number of calories you will burn during the workout. The screen will also show the duration and distance of your workout. In addition, the screen will show the number of vertical feet you will climb and a profile of the incline settings of the workout.

**To select an all-terrain trails workout,** select the desired difficulty level. Then, select the desired workout. The screen will show the duration of the workout and the approximate number of calories you will burn during the workout. The screen will also show the distance of your workout and the number of vertical feet you will climb. In addition, the screen will show a topographic map of the trail. Press the Profile button at the top of the screen near the time display to view a profile of the incline settings of the workout. To return to the map, press the Trail button at the top of the screen.

#### 4. Start the workout.

Press the Start Workout button to start the workout. A moment after you press the button, the walking belt will begin to move. Hold the handrails and begin walking.

Each workout is divided into segments. One speed setting and one incline setting are programmed for each segment. Note: The same speed setting and/or incline setting may be programmed for consecutive segments.

During the workout, the profile will show your progress. Press the Display increase and decrease buttons repeatedly to view the profile. The red line will indicate the current segment of the workout. The height of the current segment indicates the incline setting for the current segment.

At the end of the first segment of the workout, a series of tones will sound. If a different speed and/or incline setting is programmed for the second segment, the speed setting and/or incline setting will flash on the screen for a moment to alert you. The treadmill will then automatically adjust to the speed and/or incline settings for the next segment.

The workout will continue in this way until the last segment ends. The walking belt will then slow to a stop, and a workout summary will appear on the screen. After you view the workout summary, press the Done button.

If the speed or incline setting is too high or too low at any time during the workout, you can override the setting by pressing the Speed or Incline buttons; **however, when the next segment begins, the treadmill will automatically adjust to the speed and incline settings for the next segment.**

To stop the workout at any time, press the iFit Menu button in the upper right corner of the

screen. To pause the workout, press the Pause button. To end the workout and select a new workout, press the New Workout button. To end the workout, press the End Workout button.

To continue the workout, press the Resume button or the Start button. The walking belt will begin to move at 1 mph. When the next segment of the workout begins, the treadmill will automatically adjust to the speed and incline settings for the next segment.

**Note: The calorie goal is an estimate of the number of calories that you will burn during the workout. The actual number of calories that you burn will depend on your weight. In addition, if you manually change the speed or incline of the treadmill during the workout, the number of calories you burn will be affected.**

#### 5. Monitor your progress.

See step 5 on page 17. The screen can also show a profile of the incline settings of the workout. When an all-terrain trails workout is selected, the screen can show a topographic map of the trail. The person running on the trail indicates your progress.

#### 6. Measure your heart rate if desired.

See step 6 on page 18.

#### 7. Turn on the fan if desired.

See step 7 on page 18.

#### 8. When you are finished exercising, remove the key from the console.

See step 8 on page 18.

## HOW TO USE THE IFIT LIVE MODE

The iFit Live mode enables the treadmill to communicate with your wireless network. With the iFit Live mode, you can download personalized workouts, create your own workouts, track your workout results, and access many other features. See [www.iFit.com](http://www.iFit.com) for complete information.

### 1. Connect your treadmill to your own wireless network.

See steps 1 and 2 on pages 22 and 23.

To activate and use the iFit Live mode, you must have your own wireless network. You must have an 802.11b router with SSID broadcast enabled (hidden networks are not supported). You will also need an iFit.com membership.

### 2. Select the iFit Live mode.

To select the iFit Live mode, first select the start menu (see step 2 on page 16). Next, press the Workouts button, and then press the Live Workouts button. To set up an iFit Live account, or for more information about the iFit Live mode, go to [www.iFit.com](http://www.iFit.com).

To switch users, press the Switch User button in the lower right corner of the screen. Then, select the desired user.

## HOW TO USE THE STEREO SOUND SYSTEM

To play music or audio books through the console's speakers, you must connect your MP3 player, CD player, or other personal audio player to the console.

Locate the audio wire. Plug one end into the audio jack on the side of the console. Plug the other end into a jack on your MP3 player, CD player, or other personal audio player. **Make sure that the audio wire is fully plugged in.**

Next, press the Play button on your MP3 player, CD player, or other personal audio player. Then, adjust the volume level on your personal audio player or press the Vol increase and decrease buttons on the console.

If you are using a personal CD player and the CD skips, set the CD player on the floor or another flat surface instead of on the console.

## HOW TO USE THE SETTINGS MODE

The console features a settings mode that allows you to connect your treadmill to your own wireless network and to log in to your iFit Live account. The settings mode also allows you to turn on and turn off the display demo mode. You may also be able to select the unit of measurement.

### 1. Select the settings mode.

Insert the key into the console (see step 1 on page 16). Next, select the start menu (see step 2 on page 16). Then, press the **i** button in the lower right corner of the screen to select the settings mode.

### 2. Select the wireless network mode.

Press the Wireless Network button on the screen.

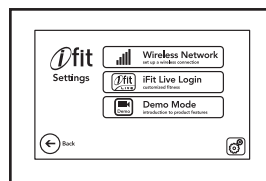

You must have your own wireless network and an 802.11b router with SSID broadcast enabled (hidden networks are not supported).

**If your wireless network is unencrypted and does not require a password, go to step 2a. If your wireless network is encrypted and requires a password, go to step 2b.**

#### 2a. Connect your treadmill to an unencrypted wireless network.

Select the desired wireless network and press the Connect button. When the Disconnect button appears, your exercise equipment is connected to the wireless network. Then, press the Done button. Go to step 3.

#### 2b. Connect your treadmill to an encrypted wireless network.

To connect to your encrypted network, you will need to know your network SSID (network name), network encryption type, and network password.

Select the desired wireless network and press the Advanced button. If your network is encrypted, you must press the Use Encryption button and fill in the entry boxes. If desired, you may also set a static IP address and/or a static domain name server (DNS).

**To use encryption**, press the Use Encryption button. Select the encryption type and enter the password. When you are finished, press the Submit button. To return to the Advanced Settings screen, press the Cancel button.

To use numbers or other characters on the keyboard on the screen, press the **?123** button or the **#+=** button. To return to the letter keyboard, press the **ABC** button. To capitalize a character, press the button with an upward-facing arrow. To clear the last character, press the button with a backward-facing arrow and an **X**.

**To use a static IP address**, press the Use Static IPs button. Enter the IP address, netmask, gateway IP address, and at least one DNS. Press the arrow buttons to view additional entry boxes. When you are finished, press the Submit button. To return to the Advanced Settings screen, press the Cancel button.

**To use a static DNS**, press the Use Static DNS button. Enter at least one DNS. Press the arrow buttons to view additional entry boxes. When you are finished, press the Submit button. To return to the Advanced Settings screen, press the Cancel button.

If necessary, press the Cancel button to exit the Advanced Settings screen.

If you are having problems connecting, unencrypt your network, update your console firmware (see step 7 on page 24), and then encrypt your network.

**Note:** If you turn on encryption on a non-encrypted network, the console will not function correctly.

**Note:** The iFit Live mode supports unsecured and secured (WEP, WPA, and WPA2) encryption. A broadband connection is recommended; performance depends on connection speed.

**Note:** If you have questions after following these instructions, go to [www.iFit.com/support](http://www.iFit.com/support) for assistance.

### 3. Log in to your iFit Live account.

Press the iFit Live Login button. Then, enter your user name and password using the keyboard on the screen. To use numbers or other characters, press the .?123 button or the #+= button. To return to the letter keyboard, press the ABC button. To capitalize a character, press the button with an upward-facing arrow. To clear the last character, press the button with a backward-facing arrow and an X. When you are finished, press the Login button. To return to the settings mode, press the Cancel button.

**To set up an iFit Live account, or for more information about the account, go to [www.iFit.com](http://www.iFit.com).**

### 4. Turn on or turn off the display demo mode.

The console features a display demo mode, designed to be used if the treadmill is displayed in a store. While the demo mode is turned on, the console will function normally when you plug in the power cord, press the power switch into the reset position, and insert the key into the console. However, when you remove the key, the screen will remain lit, although the buttons will not function.

To turn on or turn off the display demo mode, first press the Demo Mode button. Next, press the On button or the Off button. Then, press the Back button.

### 5. View the unit of measurement.

Press the US/Metric button to view the selected unit of measurement. Change the unit of measurement, if desired. Then, press the Back button.

**Note:** If you purchased your treadmill in the US, the US/Metric button may not be enabled.

### 6. Exit the settings mode.

To exit the settings mode, press the Back button.



## HOW TO USE THE MAINTENANCE MODE

The console features a maintenance mode that allows you to calibrate the incline and speed of the treadmill, restore factory defaults, calibrate the screen, update the console software, and view technical information.

### 1. Select the settings mode.

See step 1 on page 22.

### 2. Select the maintenance mode.

Press the Maintenance button in the lower right corner of the screen to enter the maintenance mode.

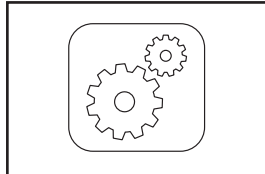

### 3. Calibrate the incline system of the treadmill.

Press the Calibrate Incline button. The frame will move upward and downward. This will calibrate the incline system. Press the Begin button to calibrate the incline system, or press the Cancel button to return to the maintenance mode. When the incline system is calibrated, press the Back button.

**IMPORTANT: Keep pets, feet, and other objects away from the treadmill while the incline system is calibrating. In an emergency, pull the key from the console to stop the calibration.**

### 4. Restore factory defaults.

If necessary, press the Restore Defaults button to reset the firmware to the original factory firmware. This will erase all firmware updates that you have downloaded. Press the Begin button to restore the default firmware, or press the Cancel button to return to the maintenance mode.

When the restoration is complete, the words PLEASE CYCLE POWER will appear in the grey box. Press the power switch into the off position, wait for several seconds, and then press the power switch into the reset position. The start menu will appear when the console is ready for use.

### 5. Calibrate the screen.

If the screen is not properly calibrated, it will be difficult for you to press the buttons on the screen. To calibrate the screen, press the Calibrate Screen button and then press the Begin button. Press the Cancel button to return to the maintenance mode.

Using a pencil eraser or other small object, press the center of the small target on the screen. Then, press the next two targets. After several seconds, the console will return to the start menu.

### 6. Calibrate the speed of the treadmill.

Calibrate the speed of the treadmill only if instructed to do so by an authorized service representative.

Note: The Calibrate Speed button may not be enabled on your treadmill.

### 7. Update the console firmware.

**For the best results, regularly check for firmware updates.**

Press the Firmware Update button. Press the Begin button to check for updates, or press the Cancel button to return to the maintenance mode.

A status bar will appear in the grey box on the screen. When the update is complete, the words PLEASE CYCLE POWER will appear in the grey box. Press the power switch into the off position, wait for several seconds, and then press the power switch into the reset position. The start menu will appear when the console is ready for use.

### 8. View technical information.

Press the Technical Info button to view the total number of hours that the treadmill has been used and the total number of miles that the walking belt has moved. After you view the information, press the Finish button.

### 9. Exit the maintenance mode.

To exit the maintenance mode, press the Back button repeatedly.



# HOW TO FOLD AND MOVE THE TREADMILL

## HOW TO FOLD THE TREADMILL

To avoid damaging the treadmill, adjust the incline to the lowest position before you fold the treadmill. Then, remove the key and unplug the power cord. **CAUTION: You must be able to safely lift 45 lbs. (20 kg) to raise, lower, or move the treadmill.**

1. Hold the metal frame firmly in the location shown by the arrow below. **CAUTION: Do not hold the frame by the plastic foot rails. Make sure to bend your legs and keep your back straight.**

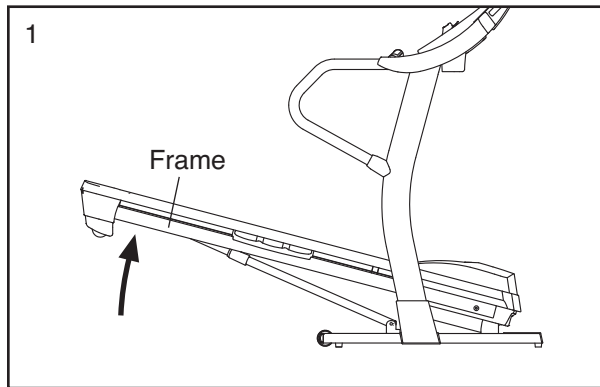

2. Raise the frame until the latch knob locks in the storage position. **CAUTION: Make sure that the latch knob locks.**

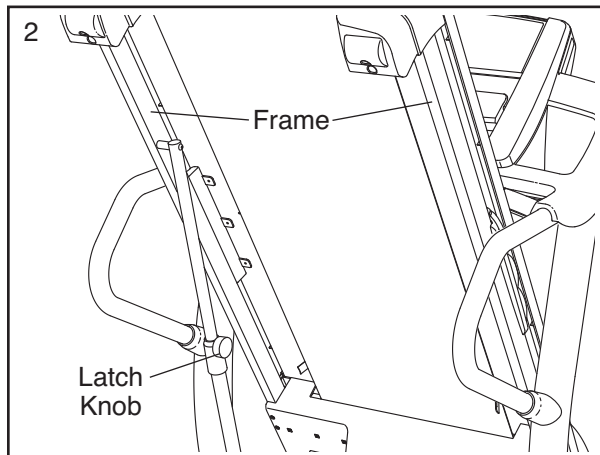

To protect the floor or carpet, place a mat under the treadmill. Keep the treadmill out of direct sunlight. Do not leave the treadmill in the storage position in temperatures above 85° F (30° C).

## HOW TO MOVE THE TREADMILL

Before moving the treadmill, fold it as described at the left. **CAUTION: Make sure that the latch knob is locked in the storage position. Moving the treadmill may require two people.**

1. Hold the frame and one of the handrails, and place one foot against a wheel.

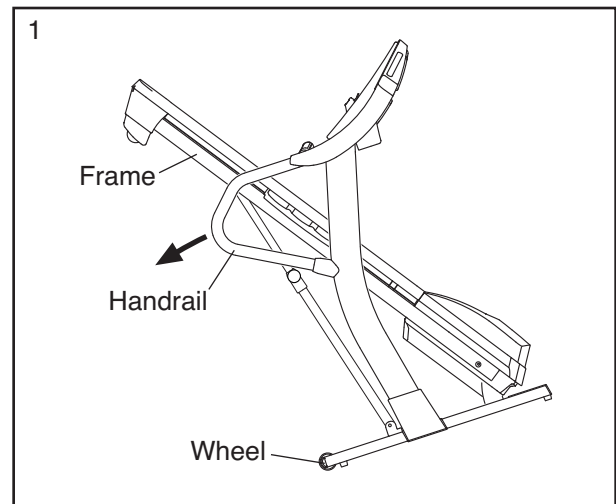

2. Pull back on the handrail until the treadmill will roll on the wheels, and carefully move it to the desired location. **CAUTION: Do not move the treadmill without tipping it back, do not pull on the frame, and do not move the treadmill over an uneven surface.**
3. Place one foot against a wheel, and carefully lower the treadmill.

## HOW TO LOWER THE TREADMILL FOR USE

1. **See drawing 2.** Hold the upper end of the treadmill with your left hand. Then, pull the latch knob to the right. **IMPORTANT: Do not turn the latch knob.** If necessary, push the frame forward slightly. Pivot the frame downward a few inches, and release the latch knob.
2. **See drawing 1 at the left.** Hold the metal frame firmly with both hands, and lower it to the floor. **CAUTION: Do not hold the frame by the plastic foot rails, and do not drop the frame. Make sure to bend your legs and keep your back straight.**

# TROUBLESHOOTING

Most treadmill problems can be solved by following the simple steps below. Find the symptom that applies, and follow the steps listed. If further assistance is needed, see the front cover of this manual.

## SYMPTOM: The power does not turn on

- Make sure that the power cord is plugged into a surge suppressor, and that the surge suppressor is plugged into a properly-grounded outlet (see page 14). Use only a single-outlet surge suppressor that meets all of the specifications described on page 14. **IMPORTANT: The treadmill is not compatible with GFCI-equipped outlets and may not be compatible with AFCI-equipped outlets.**
- After the power cord has been plugged in, make sure that the key is inserted into the console.
- Check the power switch located on the treadmill frame near the power cord. If the switch protrudes as shown, the switch has tripped. To reset the power switch, wait for five minutes and then press the switch back in.

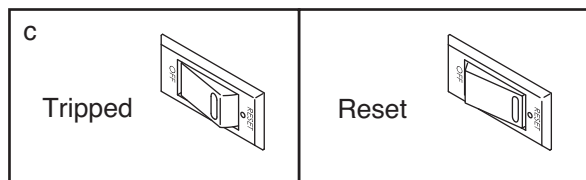

## SYMPTOM: The power turns off during use

- Check the power switch (see the drawing above). If the switch has tripped, wait for five minutes and then press the switch back in.
- Make sure that the power cord is plugged in. If the power cord is plugged in, unplug it, wait for five minutes, and then plug it back in.

- Remove the key from the console, and then reinsert it.
- If the treadmill still will not run, please see the front cover of this manual.

## SYMPTOM: The console displays remain lit when you remove the key from the console

- The console features a display demo mode, designed to be used if the treadmill is displayed in a store. If the screen shows a preset presentation when you remove the key, the demo mode is turned on. To turn off the demo mode, hold down the Stop button for a few seconds. If the demo mode is still on, see step 4 on page 23 to turn off the demo mode.

## SYMPTOM: The displays of the console do not function properly

- Remove the key from the console and **UNPLUG THE POWER CORD**. Place the treadmill in the storage position (see HOW TO FOLD THE TREADMILL on page 25). Remove the two #8 x 1 1/2" Screws (62).

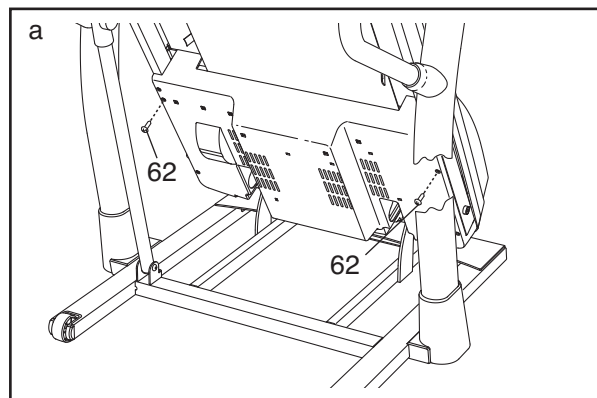

Then, lower the treadmill (see HOW TO LOWER THE TREADMILL FOR USE on page 25).

Remove the four #8 x 3/4" Screws (14), and carefully remove the Motor Hood (61).

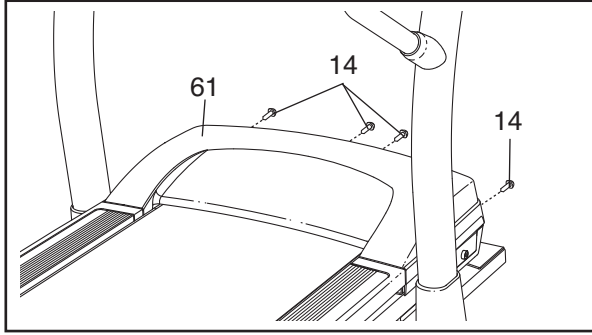

Locate the Reed Switch (44) and the Magnet (43) on the left side of the Pulley (42). Turn the Pulley until the Magnet is aligned with the Reed Switch. **Make sure that the gap between the Magnet and the Reed Switch is about 1/8 in. (3 mm).** If necessary, move the Reed Switch slightly using a slotted screwdriver. Then, reattach the Motor Hood (not shown) with the four #8 x 3/4" Screws (not shown) and the two #8 x 1 1/2" Screws (not shown). Run the treadmill for a few minutes to check for a correct speed reading.

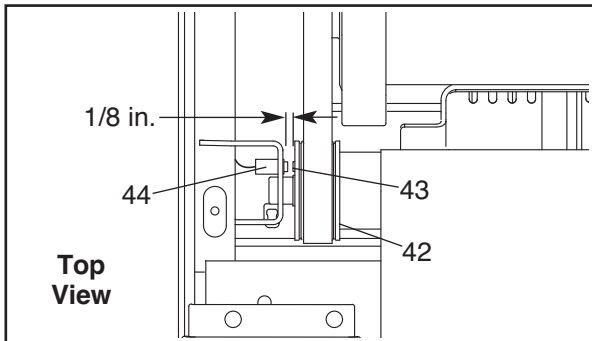

**SYMPTOM: The incline of the treadmill does not change correctly**

- a. Calibrate the incline system (see step 3 on page 24).

**SYMPTOM: The iFit Live mode is not functioning correctly**

- a. If the iFit Live mode is not functioning correctly, make sure that the treadmill has the most current firmware available (see step 7 on page 24).

**SYMPTOM: The walking belt slows when walked on**

- a. Use only a single-outlet surge suppressor that meets all of the specifications described on page 14.
- b. If the walking belt is overtightened, treadmill performance may decrease and the walking belt may become damaged. Remove the key and **UNPLUG THE POWER CORD**. Using the hex key, turn both idler roller screws counterclockwise, 1/4 of a turn. When the walking belt is properly tightened, you should be able to lift each edge of the walking belt 2 to 3 in. (5 to 7 cm) off the walking platform. Be careful to keep the walking belt centered. Then, plug in the power cord, insert the key, and run the treadmill for a few minutes. Repeat until the walking belt is properly tightened.

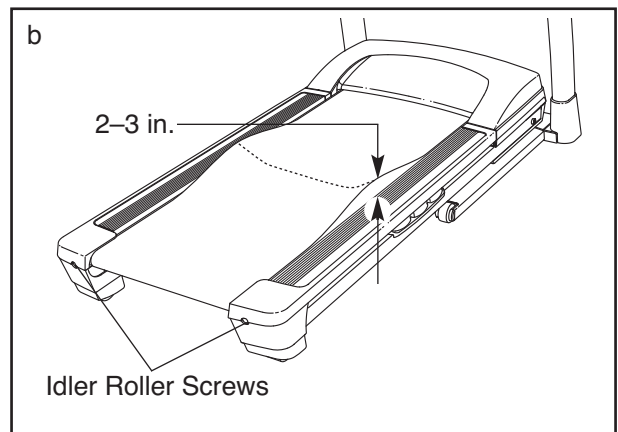

- c. Your treadmill features a walking belt coated with high-performance lubricant. **IMPORTANT: Never apply silicone spray or other substances to the walking belt or the walking platform unless instructed to do so by an authorized service representative. Such substances may deteriorate the walking belt and cause excessive wear.** If you suspect that the walking belt needs more lubricant, see the front cover of this manual.
- d. If the walking belt still slows when walked on, see the front cover of this manual.

**SYMPTOM: The walking belt is off-center or slips when walked on**

- a. **If the walking belt is off-center**, first remove the key and **UNPLUG THE POWER CORD**. **If the walking belt has shifted to the left**, use the hex key to turn the left idler roller screw clockwise 1/2 of a turn; **if the walking belt has shifted to the right**, turn the left idler roller screw counterclockwise 1/2 of a turn. Be careful not to overtighten the walking belt. Then, plug in the power cord, insert the key, and run the treadmill for a few minutes. Repeat until the walking belt is centered.

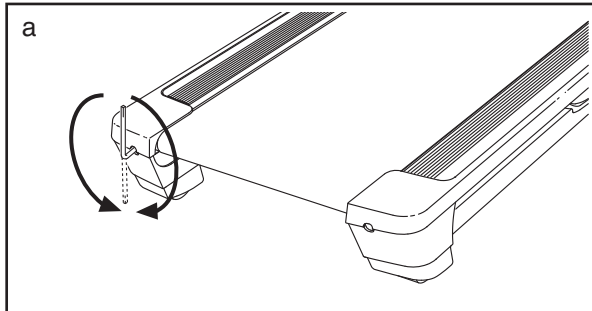

- b. **If the walking belt slips when walked on**, first remove the key and **UNPLUG THE POWER CORD**. Using the hex key, turn both idler roller screws clockwise, 1/4 of a turn. When the walking belt is correctly tightened, you should be able to lift each edge of the walking belt 2 to 3 in. (5 to 7 cm) off the walking platform. Be careful to keep the walking belt centered. Then, plug in the power cord, insert the key, and carefully walk on the treadmill for a few minutes. Repeat until the walking belt is properly tightened.

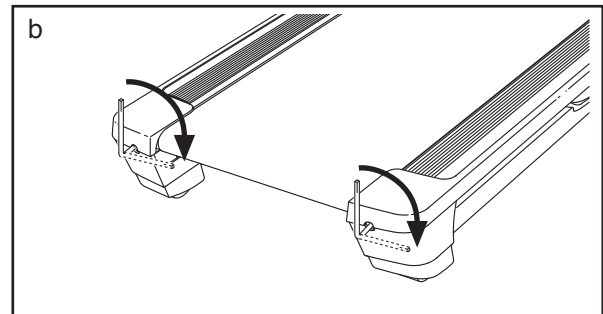

# EXERCISE GUIDELINES

**⚠️ WARNING:** Before beginning this or any exercise program, consult your physician. This is especially important for persons over age 35 or persons with pre-existing health problems.

The heart rate monitor is not a medical device. Various factors may affect the accuracy of heart rate readings. The heart rate monitor is intended only as an exercise aid in determining heart rate trends in general.

These guidelines will help you to plan your exercise program. For detailed exercise information, obtain a reputable book or consult your physician. Remember, proper nutrition and adequate rest are essential for successful results.

## EXERCISE INTENSITY

Whether your goal is to burn fat or to strengthen your cardiovascular system, exercising at the proper intensity is the key to achieving results. You can use your heart rate as a guide to find the proper intensity level. The chart below shows recommended heart rates for fat burning and aerobic exercise.

165	155	145	140	130	125	115	♥
145	138	130	125	118	110	103	♥
125	120	115	110	105	95	90	♥
<hr/>							
20	30	40	50	60	70	80	

To find the proper intensity level, find your age at the bottom of the chart (ages are rounded off to the nearest ten years). The three numbers listed above your age define your “training zone.” The lowest number is the heart rate for fat burning, the middle number is the heart rate for maximum fat burning, and the highest number is the heart rate for aerobic exercise.

**Burning Fat**—To burn fat effectively, you must exercise at a low intensity level for a sustained period of time. During the first few minutes of exercise, your body uses *carbohydrate calories* for energy. Only after the first few minutes of exercise does your body begin to use stored *fat calories* for energy. If your goal is to burn fat, adjust the intensity of your exercise until your heart rate is near the lowest number in your training zone. For maximum fat burning, exercise with your heart rate near the middle number in your training zone.

**Aerobic Exercise**—If your goal is to strengthen your cardiovascular system, you must perform aerobic exercise, which is activity that requires large amounts of oxygen for prolonged periods of time. For aerobic exercise, adjust the intensity of your exercise until your heart rate is near the highest number in your training zone.

## WORKOUT GUIDELINES

**Warming Up**—Start with 5 to 10 minutes of stretching and light exercise. A warm-up increases your body temperature, heart rate, and circulation in preparation for exercise.

**Training Zone Exercise**—Exercise for 20 to 30 minutes with your heart rate in your training zone. (During the first few weeks of your exercise program, do not keep your heart rate in your training zone for longer than 20 minutes.) Breathe regularly and deeply as you exercise—never hold your breath.

**Cooling Down**—Finish with 5 to 10 minutes of stretching. Stretching increases the flexibility of your muscles and helps to prevent post-exercise problems.

## EXERCISE FREQUENCY

To maintain or improve your condition, complete three workouts each week, with at least one day of rest between workouts. After a few months of regular exercise, you may complete up to five workouts each week, if desired. Remember, the key to success is to make exercise a regular and enjoyable part of your everyday life.

# PART LIST

Model No. PFTL01411.0 R0911A

Key No.	Qty.	Description	Key No.	Qty.	Description
1	14	#8 x 1/2" Screw	51	1	Storage Latch
2	4	#8 x 1" Tek Screw	52	4	#8 x 1" Screw
3	1	3/8" x 2" Bolt	53	1	Electronics Bracket
4	6	5/16" x 1 1/2" Screw	54	1	Controller
5	4	5/16" x 3/4" Screw	55	1	Frame
6	1	3/8" x 1 3/4" Screw	56	1	Idler Roller
7	4	3/8" x 5 1/2" Screw	57	1	Right Frame Foot
8	4	1/4" x 1/2" Screw	58	1	Left Frame Foot
9	8	5/16" Star Washer	59	1	Hex Key
10	5	3/8" Nut	60	1	5/32" Hex Key
11	4	3/8" Star Washer	61	1	Motor Hood
12	2	1/4" Star Washer	62	2	#8 x 1 1/2" Screw
13	1	Pulse Crossbar	63	2	Lift Frame Spacer
14	36	#8 x 3/4" Screw	64	2	Frame Spacer
15	2	1/4" x 1 3/4" Bolt	65	1	Lift Frame
16	2	3/8" x 1 3/4" Bolt	66	1	Incline Motor
17	8	#8 x 1/2" Washer Head Screw	67	2	Incline Motor Spacer
18	12	#12 x 1" Screw	68	2	Hood Mount
19	4	Belt Guide Screw	69	1	Belly Pan
20	2	Drive Motor Screw	70	1	Power Switch
21	4	3/8" x 2 1/8" Bolt	71	1	Power Cord
22	2	3/8" x 1 1/8" Bolt	72	2	Grommet
23	4	5/16" x 1 1/4" Bolt	73	1	Lift Motor Wire
24	1	Drive Roller Screw	74	3	Releasable Tie
25	2	1/4" Flat Washer	75	1	15 1/2" Tie
26	2	1/4" Lock Washer	76	11	8" Tie
27	2	Cage Nut	77	2	Handrail Cover
28	6	#8 x 3/4" Truss Head Screw	78	1	Left Handrail
29	2	3/8" Jam Nut	79	1	Right Handrail
30	4	5/16" Flange Nut	80	2	Console Clamp
31	4	Hood Clip	81	1	Console Frame
32	1	1/4" Star Washer	82	1	Left Upright
33	2	#8 Star Washer	83	1	Right Upright
34	4	#8 x 1" Truss Head Screw	84	1	Base Cover
35	1	Left Foot Rail	85	1	Upright Wire
36	1	Warning Decal	86	1	Right Upright Cover
37	2	Platform Cushion	87	1	Left Upright Cover
38	1	Walking Platform	88	4	Screw Spacer
39	2	Belt Guide	89	2	Caution Decal
40	1	Left Foot Rail Cover	90	1	Left Upright Spacer
41	1	Right Foot Rail Cover	91	1	Right Upright Spacer
42	1	Drive Roller/Pulley	92	4	Base Foot
43	1	Magnet	93	1	Audio Wire
44	1	Reed Switch	94	1	Base
45	1	Reed Switch Clamp	95	2	Wheel
46	1	Drive Motor Belt	96	2	Wheel Housing
47	1	Drive Motor	97	2	Wheel Axle
48	1	Walking Belt	98	1	Key/Clip
49	1	Incline Sensor Wire	99	8	Wire Tie
50	1	Right Foot Rail	100	1	Console

<b>Key No.</b>	<b>Qty.</b>	<b>Description</b>	<b>Key No.</b>	<b>Qty.</b>	<b>Description</b>
101	1	Left Accessory Tray	106	1	Pulse Bar
102	1	Console Base	107	3	Pulse Ground Wire
103	1	Wire Tie Clamp	108	1	Site Warning Decal
104	1	Right Accessory Tray	*	–	User's Manual
105	1	Access Door			

Note: Specifications are subject to change without notice. For information about ordering replacement parts, see the back cover of this manual. \*These parts are not illustrated.



# EXPLODED DRAWING A

Model No. PFTL01411.0 R0911A

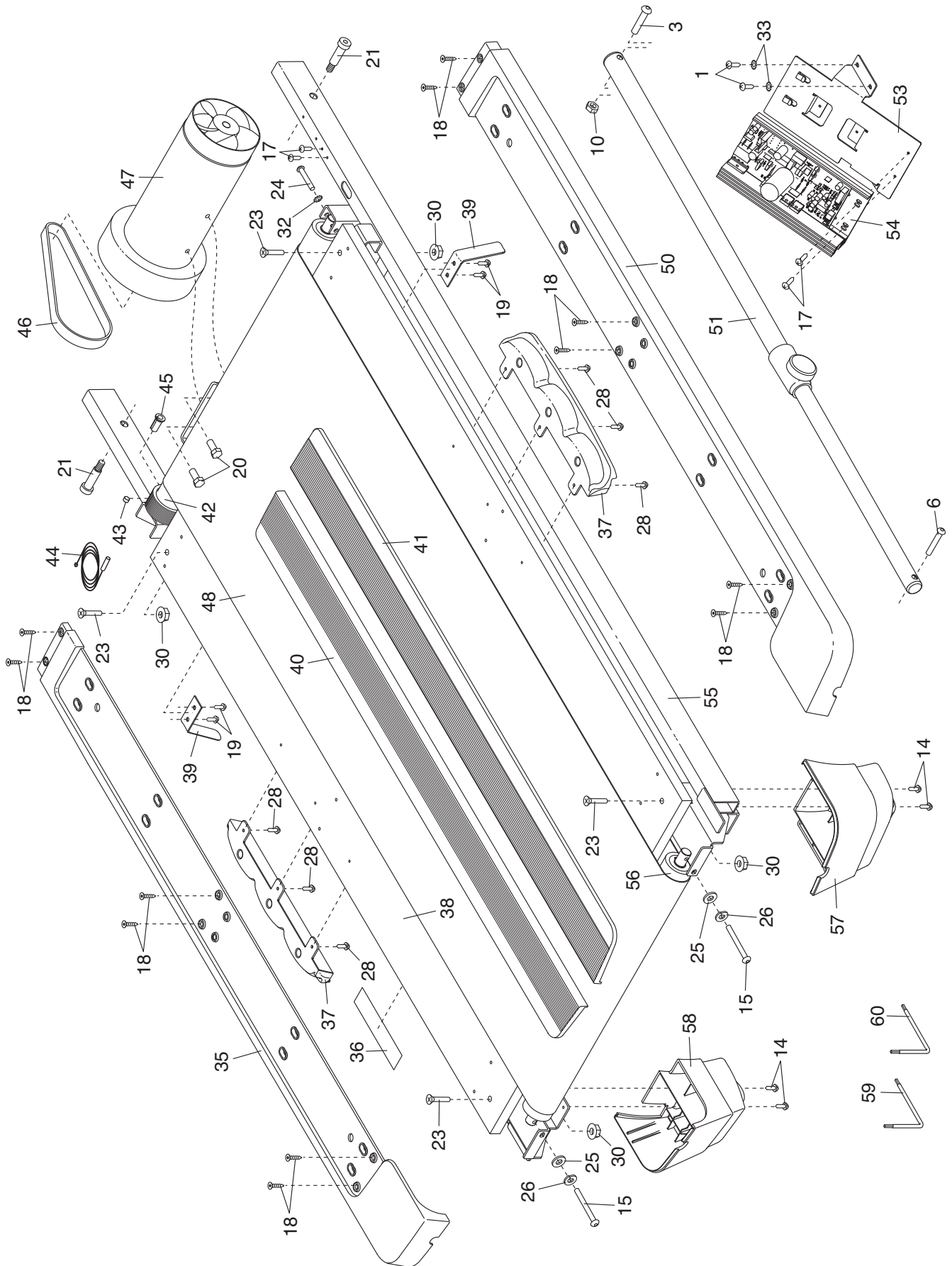



# EXPLODED DRAWING B

Model No. PFTL01411.0 R0911A

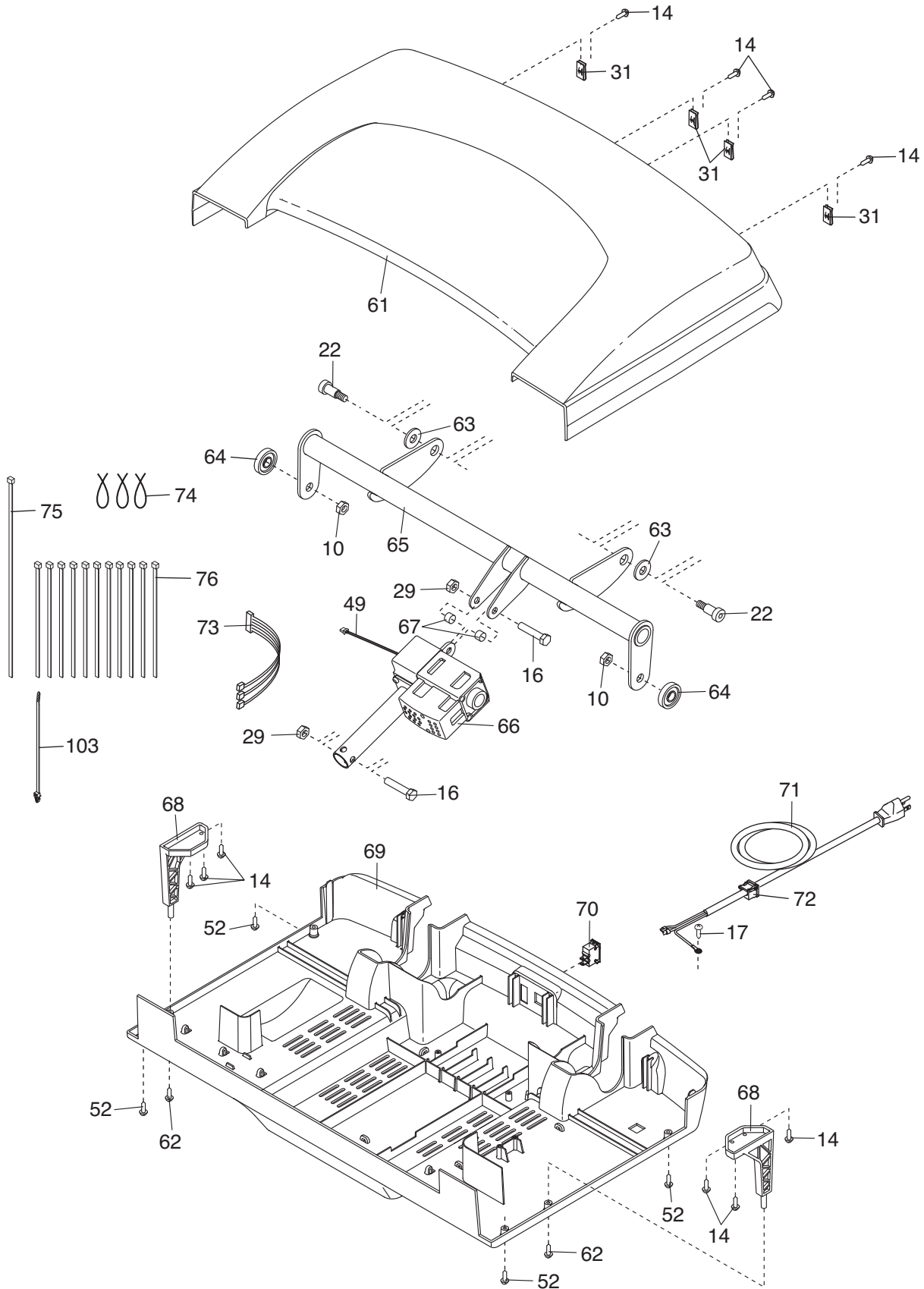

# EXPLODED DRAWING C

Model No. PFTL01411.0 R0911A

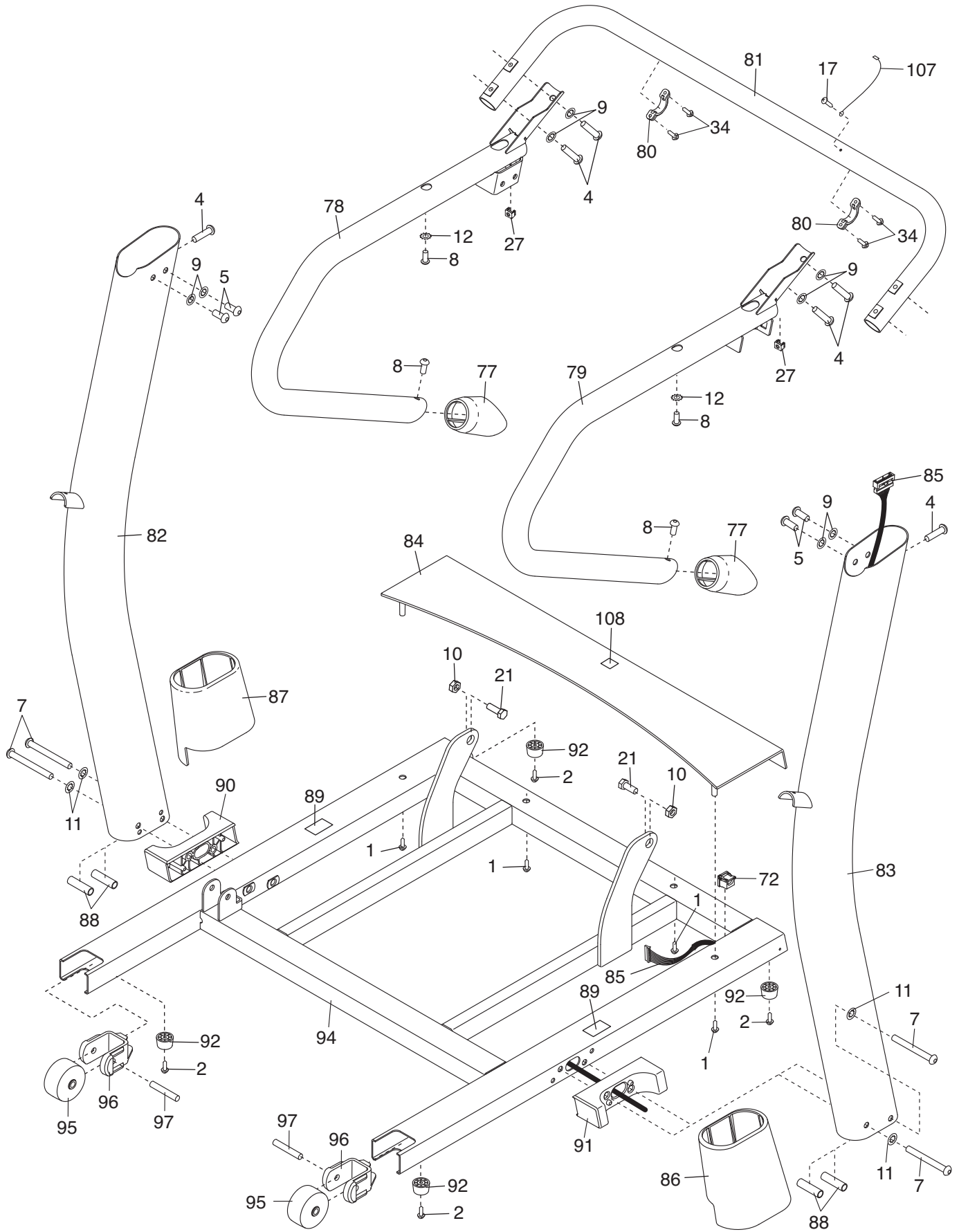

# EXPLODED DRAWING D

Model No. PFTL01411.0 R0911A

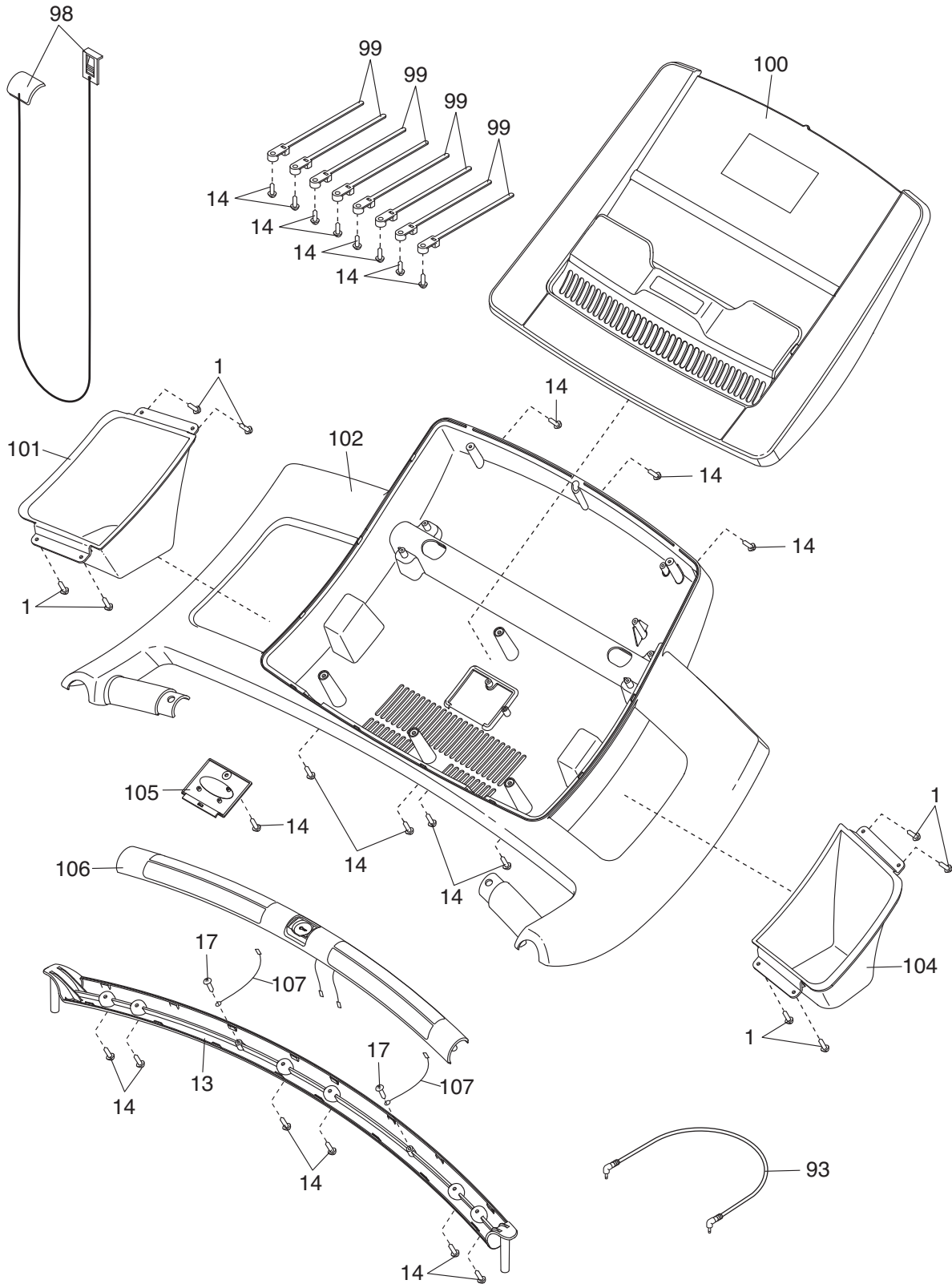

---

# ORDERING REPLACEMENT PARTS

To order replacement parts, please see the front cover of this manual. To help us assist you, be prepared to provide the following information when contacting us:

- the model number and serial number of the product (see the front cover of this manual)
- the name of the product (see the front cover of this manual)
- the key number and description of the replacement part(s) (see the PART LIST and the EXPLODED DRAWING near the end of this manual)

## LIMITED WARRANTY

**IMPORTANT: You must register this product within 30 days of the purchase date to avoid added fees for service needed under warranty. Go to [www.proformservice.com/registration](http://www.proformservice.com/registration).**

ICON Health & Fitness, Inc. (ICON) warrants this product to be free from defects in workmanship and material, under normal use and service conditions. The frame and drive motor are warranted for a lifetime. Parts and labor are warranted for one (1) year from the date of purchase.

This warranty extends only to the original purchaser (customer). ICON's obligation under this warranty is limited to repairing or replacing, at ICON's option, the product through one of its authorized service centers. All repairs for which warranty claims are made must be preauthorized by ICON. If the product is shipped to a service center, freight charges to and from the service center will be the customer's responsibility. If replacement parts are shipped while the product is under warranty, the customer will be responsible for a minimal handling charge. For in-home service, the customer will be responsible for a minimal trip charge. This warranty does not extend to freight damage to the product. This warranty will automatically be voided if the product is used as a store display model, if the product is purchased or transported outside the USA, if all instructions in this manual are not followed, if the product is abused or improperly or abnormally used, or if the product is used for commercial or rental purposes. No other warranty beyond that specifically set forth above is authorized by ICON.

ICON is not responsible or liable for indirect, special, or consequential damages arising out of or in connection with the use or performance of the product; damages with respect to any economic loss, loss of property, loss of revenues or profits, loss of enjoyment or use, or costs of removal or installation; or other consequential damages of any kind. Some states do not allow the exclusion or limitation of incidental or consequential damages. Accordingly, the above limitation may not apply to the customer.

The warranty extended hereunder is in lieu of any and all other warranties, and any implied warranties of merchantability or fitness for a particular purpose are limited in their scope and duration to the terms set forth herein. Some states do not allow limitations on how long an implied warranty lasts. Accordingly, the above limitation may not apply to the customer.

This warranty provides specific legal rights; the customer may have other rights that vary from state to state.

**ICON Health & Fitness, Inc., 1500 S. 1000 W., Logan, UT 84321-9813**