

Model No. PFTL58590

Serial No. _____

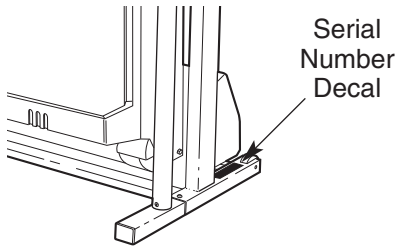

PRO-FORM[®]

525C

TARGET PULSE ANALYSIS

USER'S MANUAL

QUESTIONS?

As a manufacturer, we are committed to providing complete customer satisfaction. If you have questions, or if there are missing or damaged parts, we will guarantee complete satisfaction through direct assistance from our factory.

TO AVOID UNNECESSARY DELAYS, PLEASE CALL DIRECT TO OUR TOLL-FREE CUSTOMER HOT LINE. The trained technicians on our Customer Hot Line will provide immediate assistance, free of charge to you.

CUSTOMER HOT LINE:

1-800-999-3756

Mon.-Fri., 6 a.m.-6 p.m. MST

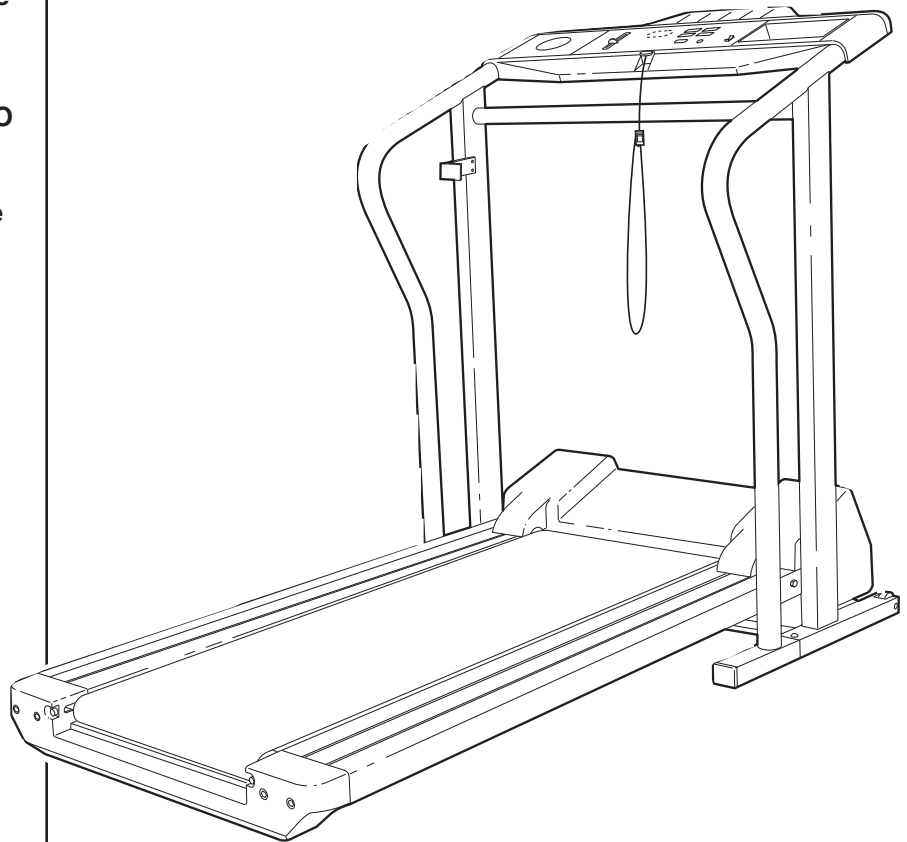

CAUTION

Read all precautions and instructions in this manual before using this equipment. Save this manual for future reference.



Visit our website at

www.proform.com

*new products, prizes,
fitness tips, and much more!*

TABLE OF CONTENTS

IMPORTANT PRECAUTIONS	2
BEFORE YOU BEGIN	4
ASSEMBLY	5
OPERATION AND ADJUSTMENT	7
HOW TO FOLD AND MOVE THE TREADMILL	10
MAINTENANCE AND TROUBLE-SHOOTING	12
CONDITIONING GUIDELINES	14
ORDERING REPLACEMENT PARTS	Back Cover
LIMITED WARRANTY	Back Cover

Note: An EXPLODED DRAWING and PART LIST are attached in the center of this manual. Please save them for future reference.

IMPORTANT PRECAUTIONS

⚠ WARNING: To reduce the risk of burns, fire, electric shock, or injury to persons, read the following important precautions and information before operating the treadmill.

1. It is the responsibility of the owner to ensure that all users of this treadmill are adequately informed of all warnings and precautions.
2. Use the treadmill only as described in this manual.
3. Place the treadmill on a level surface, with at least eight feet of clearance behind it. Do not place the treadmill on any surface that blocks air openings. To protect the floor or carpet from damage, place a mat under the treadmill.
4. Keep the treadmill indoors, away from moisture and dust. Do not put the treadmill in a garage or covered patio, or near water.
5. Do not operate the treadmill where aerosol products are used or where oxygen is being administered.
6. Keep children under the age of 12 and pets away from the treadmill at all times.
7. The treadmill should not be used by persons weighing more than 250 pounds.
8. Never allow more than one person on the treadmill at a time.
9. Wear appropriate exercise clothing when using the treadmill. Do not wear loose clothing that could become caught in the treadmill. Athletic support clothes are recommended for both men and women. *Always wear athletic shoes. Never use the treadmill with bare feet, wearing only stockings, or in sandals.*
10. When connecting the power cord (see page 7), plug the power cord into a surge protector (not included) and plug the surge protector into a grounded circuit capable of carrying 15 or more amps. No other appliance should be on the same circuit. Do not use an extension cord.
11. Use only a UL-listed surge protector, rated at 15 amps, with a 14-gauge cord of five feet or less in length. Do not use an extension cord.
12. Keep the power cord and the surge protector away from heated surfaces.
13. Never move the walking belt while the power is turned off. Do not operate the treadmill if the power cord or plug is damaged, or if the treadmill is not working properly. (See **BEFORE YOU BEGIN** on page 4 if the treadmill is not working properly.)

14. Never start the treadmill while you are standing on the walking belt. Always hold the handrails while using the treadmill.
15. The treadmill is capable of high speeds. Adjust the speed in small increments to avoid sudden jumps in speed.
16. Never leave the treadmill unattended while it is running. Always remove the key and unplug the power cord when the treadmill is not in use.
17. The pulse sensor is not a medical device. Various factors, including the user's movement, may affect the accuracy of heart rate readings. The pulse sensor is intended only as an exercise aid in determining heart rate trends in general.
18. Do not attempt to raise, lower, or move the treadmill until it is properly assembled. (See ASSEMBLY on page 5, and HOW TO MOVE THE TREADMILL on page 10.) You must be able to safely lift 45 pounds (20 kg) in order to raise, lower, or move the treadmill.
19. Do not change the incline of the treadmill by placing objects under the treadmill.
20. When folding or moving the treadmill, make sure that the storage latch is fully closed.
21. Inspect and tighten all parts of the treadmill regularly.
22. Never drop or insert any object into any opening.
23. **DANGER:** Always unplug the power cord immediately after use, before cleaning the treadmill, and before performing the maintenance and adjustment procedures described in this manual. Never remove the motor hood unless instructed to do so by an authorized service representative. Servicing other than the procedures in this manual should be performed by an authorized service representative only.
24. This treadmill is intended for in-home use only. Do not use this treadmill in any commercial, rental, or institutional setting.

⚠ WARNING: Before beginning this or any exercise program, consult your physician. This is especially important for persons over the age of 35 or persons with pre-existing health problems. Read all instructions before using. ICON assumes no responsibility for personal injury or property damage sustained by or through the use of this product.

SAVE THESE INSTRUCTIONS

The decal shown has been placed on your treadmill. If the decal is missing, or if it is not legible, please call our Customer Service Department, toll-free, to order a free replacement decal (see ORDERING REPLACEMENT PARTS on the back cover of this manual). Apply the decal in the location shown.

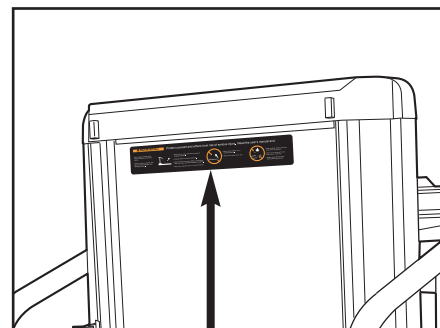

Note: The decal is shown at 38% of actual size.

⚠ WARNING:

Protect yourself and others from risk of serious injury. Read the user's manual and:

- Fully engage storage latch before treadmill is moved or stored.
- Reduce incline to lowest level before folding treadmill into storage position.



- Stand only on side rails when starting or stopping treadmill.
- Change speed in small increments.
- Hold handrails to prevent falling, and always wear the safety clip while operating treadmill.
- Stop if you feel faint, dizzy, or short of breath.



- Never allow children on or around treadmill.
- Remove key when not in use.



- Keep clothing, fingers, and hair away from moving belt.
- Never try to adjust or fix the belt while it is moving.
- Always wear athletic shoes while operating treadmill.

BEFORE YOU BEGIN

Thank you for selecting the PROFORM® 525C treadmill. The 525C treadmill combines advanced technology with innovative design to let you enjoy an excellent form of cardiovascular exercise in the convenience and privacy of your home. And when you're not exercising, the unique 525C can be folded up, requiring less than half the floor space of other treadmills.



For your benefit, read this manual carefully before using the treadmill. If you have additional questions, please call our Customer Service Department toll-free

at 1-800-999-3756, Monday through Friday, 6 a.m. until 6 p.m. Mountain Time (excluding holidays). To help us assist you, please note the product model number and serial number before calling. The model number of the treadmill is PFTL58590. The serial number can be found on a decal attached to the treadmill (see the front cover of this manual for the location).

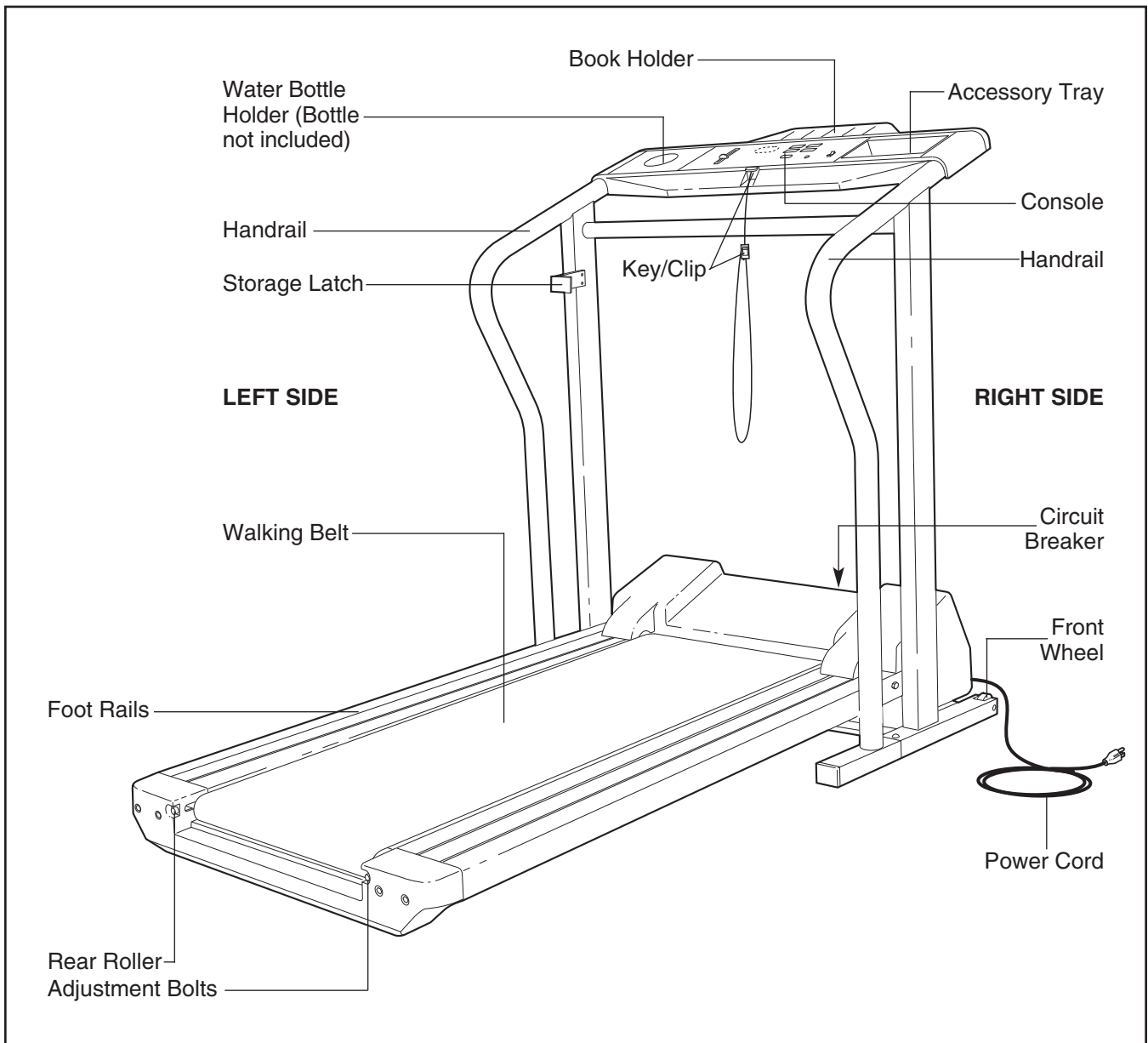
Before reading further, please review the drawing below and familiarize yourself with the labeled parts.

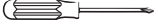

ASSEMBLY

Assembly requires two people. Set the treadmill in a cleared area and remove all packing materials. Do not dispose of the packing materials until assembly is completed. **Assembly requires the included allen wrench and your own phillips screwdriver** , **adjustable wrench** , and **scissors** .

Note: The underside of the treadmill walking belt is coated with high-performance lubricant. During shipping, a small amount of lubricant may be transferred to the top of the walking belt or the shipping carton. This is a normal condition and does not affect treadmill performance. If there is lubricant on top of the walking belt, simply wipe off the lubricant with a soft cloth and a mild, non-abrasive cleaner.

1. With the help of a second person, carefully raise the treadmill to the upright position.

While the other person tips the treadmill to one side and holds it, insert an Extension Leg (59) into one side of the treadmill. Make sure that the Extension Leg is turned so the bracket is on the top as shown. Using the Allen Wrench (102), Attach the Extension Leg with an Extension Leg Screw (57). Attach the other Extension Leg in the same manner.

Note: One replacement Base Pad (55) may be included. Use the extra Pad if one becomes worn or needs to be replaced.

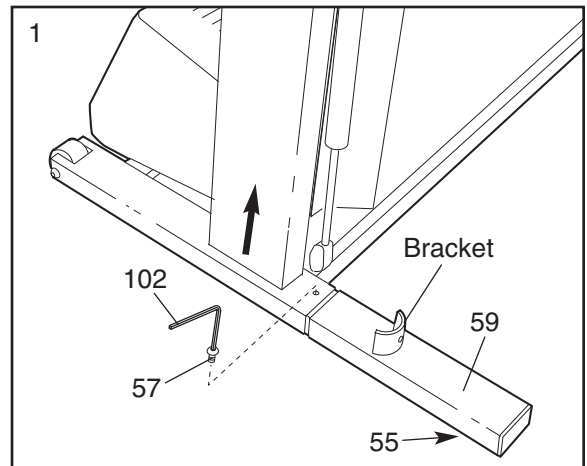

2. Refer to HOW TO LOWER THE TREADMILL FOR USE on page 11. Follow the instructions in step 2 to lower the treadmill.

Cut the plastic ties holding the cage nuts in the upper end of each Handrail (60, 62).

Position the Left Handrail (60) on the left Upright (32) as shown. The bracket on the Extension Leg (59) should be **inside** of the lower end of the Left Handrail (see the inset drawing). Thread two Handrail Bolts (30) with Handrail Washers (40) into the left Upright and the Left Handrail. **Do not tighten the Handrail Bolts yet.**

While another person holds the Console Base (46), insert all excess Wire Harness (35) through the Right Handrail (62) and into the right Upright. Next, attach the Right Handrail in the same way that you attached the Left Handrail. **Be careful to avoid damaging the Wire Harness (35).**

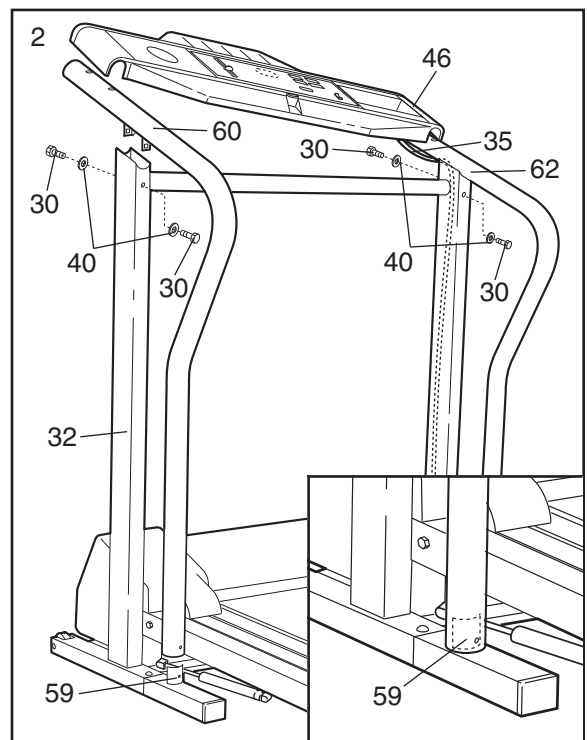

- Set the Console Base (46) on the Handrails (60, 62). Route the Wire Harness (35) under the Console Base as shown and then press the Wire Harness up into the Console Base. Insert any slack into the Right Handrail (62).

Attach the Console Base (46) to the Handrails (60, 62) with the four Long Console Screws (24).

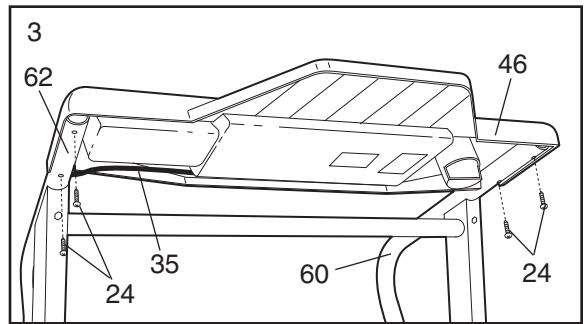

- Attach the Storage Latch (34) and the two Latch Spacers (33) to the left Upright (32) with two Screws (28). **Be careful not to overtighten the Screws.**

Note: If it is difficult to fold or lower the treadmill, remove one or both of the Latch Spacers (33).

Fold the treadmill to the storage position (see HOW TO FOLD THE TREADMILL FOR STORAGE on page 10).

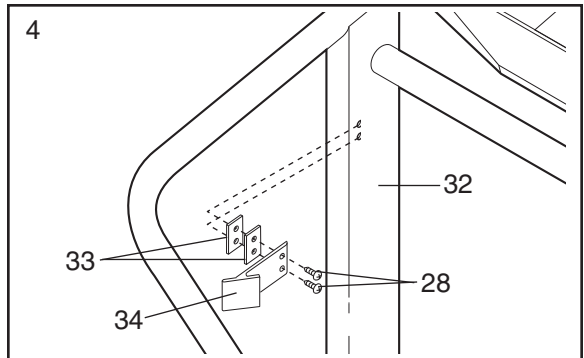

- Attach the lower end of the Right Handrail (62) to the right Extension Leg (59) with a Screw (28).

Attach the lower end of the Left Handrail (60) in the same way.

Tighten all parts used in this step and in step 2.

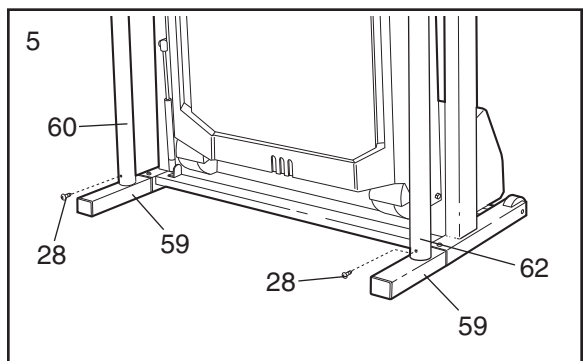

- The console requires three "AA" batteries (**not included**). Alkaline batteries are recommended. To install batteries, first **touch the Handrail (6) to discharge any static**. Next, open the Battery Cover (23). Press the batteries into the battery compartment, with the negative (-) ends of the batteries touching the springs. Close the battery cover, push up on the tab, and then push the tab forward as shown in the inset drawing. Be sure that the tab locks into place.

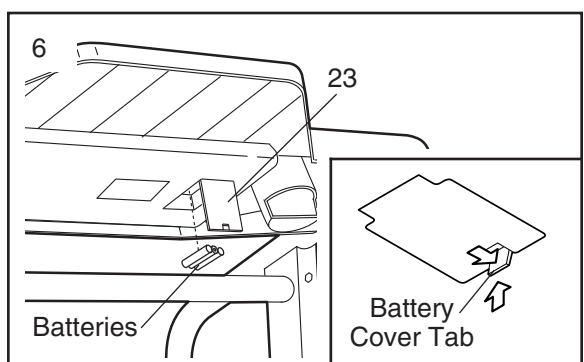

- Make sure that all parts are tightened before you use the treadmill.** Keep the included allen wrench in a secure place. The allen wrench is used to adjust the walking belt (see page 13). To protect the floor or carpet, place a mat under the treadmill.

OPERATION AND ADJUSTMENT

THE PERFORMANT LUBE™ WALKING BELT

Your treadmill features a walking belt coated with PERFORMANT LUBE™, a high-performance lubricant. **IMPORTANT: Never apply silicone spray or other substances to the walking belt or the walking platform. They will deteriorate the walking belt and cause excessive wear.**

HOW TO PLUG IN THE POWER CORD

⚠ DANGER: Improper connection of the equipment-grounding conductor can result in an increased risk of electric shock. Check with a qualified electrician or serviceman if you are in doubt as to whether the product is properly grounded. Do not modify the plug provided with the product—if it will not fit the outlet, have a proper outlet installed by a qualified electrician.

Your treadmill, like any other type of sophisticated electronic equipment, can be seriously damaged by sudden voltage changes in your home's power. Voltage surges, spikes, and noise interference can result from weather conditions or from other appliances being turned on or off.

To decrease the possibility of your treadmill being damaged, always use a surge protector (not included) with your treadmill.

Surge protectors are sold at most hardware stores and department stores. Use only a UL-listed surge protector, rated at 15 amps, with a 14-gauge cord of five feet or less in length.

This product must be grounded. If it should malfunction or break down, grounding provides a path of least resistance for electric current to reduce the risk

of electric shock. This product is equipped with a cord having an equipment-grounding conductor and a grounding plug. **Plug the power cord into a surge protector, and plug the surge protector into an appropriate outlet that is properly installed and grounded in accordance with all local codes and ordinances.**

This product is for use on a nominal 120-volt circuit, and has a grounding plug that looks like the plug illustrated in drawing 1 below. A temporary adapter that looks like the adapter illustrated in drawing 2 may be used to connect the surge protector to a 2-pole receptacle as shown in drawing 2 if a properly grounded outlet is not available.

The temporary adapter should be used only until a properly grounded outlet (drawing 1) can be installed by a qualified electrician.

The green-colored rigid ear, lug, or the like extending from the adapter must be connected to a permanent ground such as a properly grounded outlet box cover. Whenever the adapter is used it must be held in place by a metal screw. **Some 2-pole receptacle outlet box covers are not grounded. Contact a qualified electrician to determine if the outlet box cover is grounded before using an adapter.**

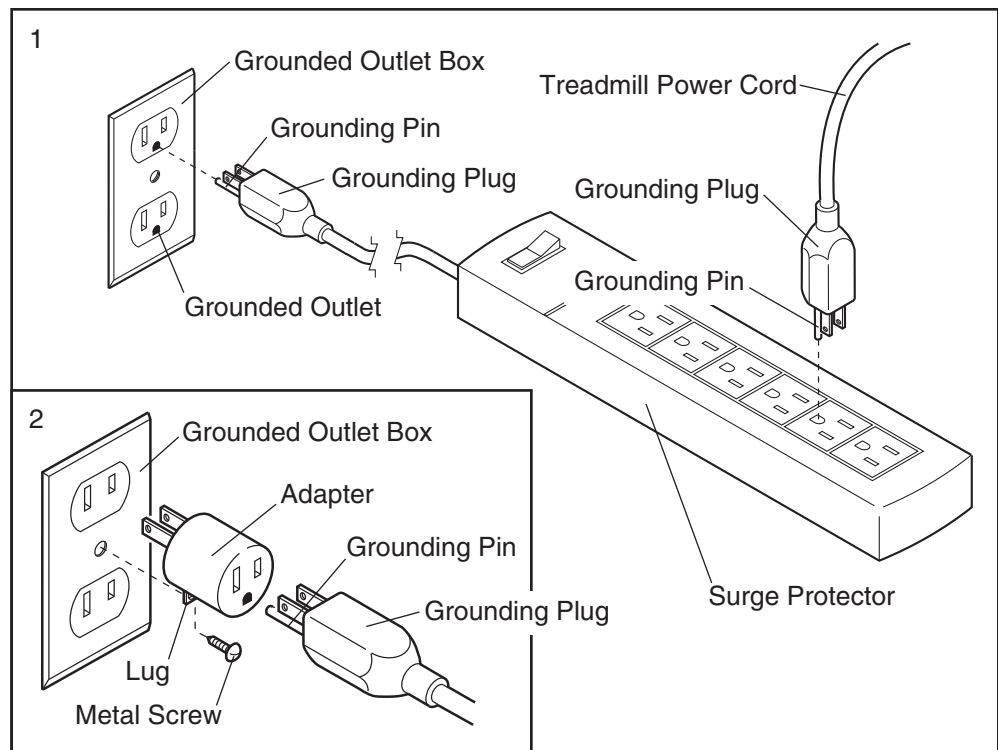
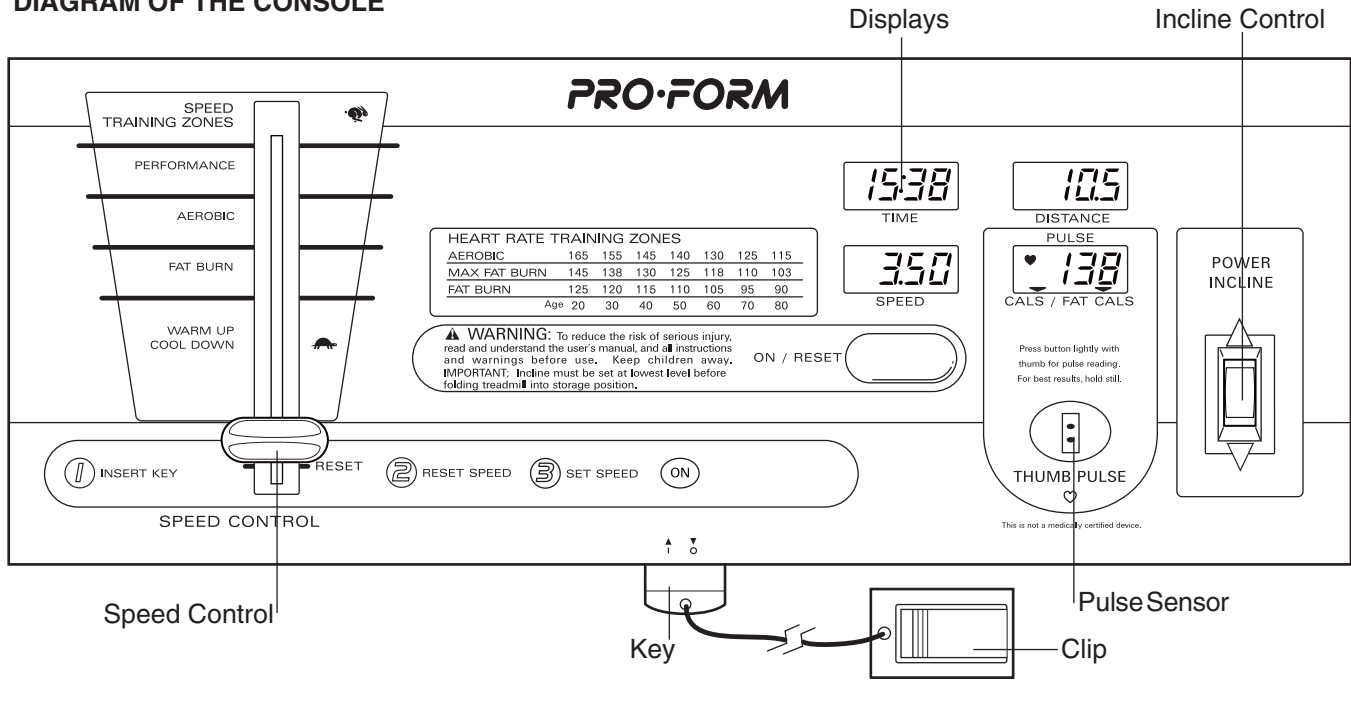

DIAGRAM OF THE CONSOLE



CAUTION: Before operating the console, read the following precautions.

- Do not stand on the walking belt when turning on the power.
- Always wear the clip (see the drawing above) while operating the treadmill. When the key is removed from the console, the walking belt will stop.
- Adjust the speed in small increments.
- The training zones marked beside the speed control are general guidelines only. See page 14 or more information.
- To reduce the possibility of electric shock, keep the console dry. Avoid spilling liquids on the console and use only a sealable water bottle.

STEP BY STEP CONSOLE OPERATION

Before operating the console, make sure that the power cord is properly plugged in. (See HOW TO PLUG IN THE POWER CORD on page 7.) In addition, make sure that batteries are installed in the console. (See step 6 on page 6.) If there is a thin sheet of clear plastic on the console, remove it.

Step onto the foot rails of the treadmill. Next, find the clip attached to the key (see the drawing above). Slide the clip onto your waistband.

Follow the steps below to operate the console.

1 Insert the key fully into the power switch.

Note: Inserting the key will not turn on the displays. The displays will turn on when the ON/RESET button is pressed or when the walking belt is started. If you just installed batteries, the displays will already be on.

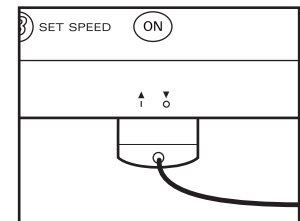

2 Reset the console and start the walking belt.

Slide the speed control to the RESET position. **Note: Each time the walking belt is stopped, the speed control must be moved to the RESET position before the walking belt can be restarted.**

Next, slowly slide the speed control until the walking belt begins to move at slow speed. Carefully step onto the walking belt and begin exercising. Change the speed of the walking belt as desired by moving the speed control.

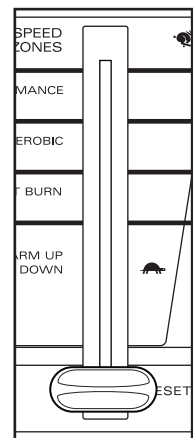

To stop the walking belt, step onto the foot rails and slide the speed control to the RESET position.

3 Follow your progress with the four displays.

TIME display—This display shows the elapsed time.



DISTANCE display—This display shows the distance that you have walked or run, in miles.

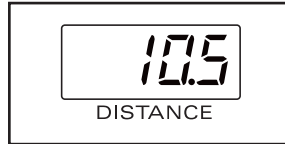

SPEED display—This display shows the speed of the walking belt, in miles per hour.



CALORIES/FAT CALORIES/PULSE display—This display shows the approximate numbers of *calories* and *fat calories* you have burned. (See FAT BURNING on page 14.) Every seven seconds, the display will change from one number to the other, as indicated by the mode arrows. This display also shows your pulse when the pulse sensor is used (see step 4).

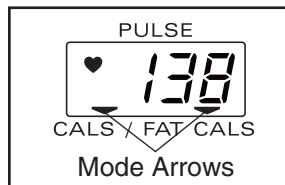

The displays can be reset, if desired, by pressing the ON/RESET button.



4 Measure your pulse, if desired.

To measure your pulse, stand on the foot rails and place your thumb on the pulse sensor as shown. The pulse sensor is pressure activated—fully press it down. **Do not press too hard, or the circulation in your thumb will be restricted, and your**

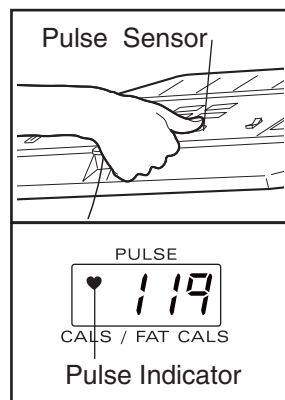

pulse will not be detected. Next, raise your thumb slightly until the heart-shaped indicator in the pulse display flashes **steadily**. Hold your thumb at this level. After a few seconds, three dashes will appear in the display and your pulse will be shown. Hold your thumb on the sensor for another 15 seconds for the most accurate reading.

If the displayed pulse appears to be too high or too low, or if your pulse is not displayed, lift your thumb off the sensor and allow the display to reset. Press down again on the sensor as described above. Make sure that your thumb is positioned as shown, and that you are applying the proper amount of pressure to the pulse sensor. Try the sensor several times until you become familiar with it. Remember to stand still while measuring your pulse.

5 Adjust the incline of the treadmill as desired.

To change the incline, press the top or bottom of the incline control until the desired incline level is reached.

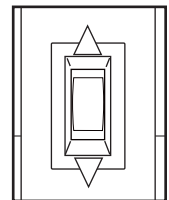

6 Turn off the power.

To turn off the power, simply wait for about four minutes. If the walking belt is stationary and the console buttons are not pressed for four minutes, the power will turn off automatically.

HOW TO FOLD AND MOVE THE TREADMILL

HOW TO FOLD THE TREADMILL FOR STORAGE

Before folding the treadmill, adjust the incline to the lowest position. If this is not done, the treadmill may be permanently damaged. Next, unplug the power cord. **CAUTION: You must be able to safely lift 45 pounds (20 kg) in order to raise, lower, or move the treadmill.**

1. Hold the treadmill with your hands in the locations shown at the right. **Caution: To decrease the possibility of injury, bend your legs and keep your back straight. As you raise the treadmill, make sure to lift with your legs rather than your back.** Raise the treadmill about halfway to the vertical position.

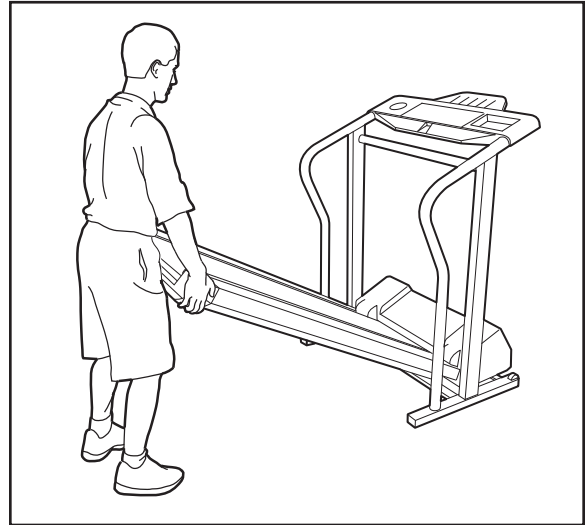

2. Move your right hand to the position shown and hold the treadmill firmly. Using your left thumb, press the storage latch to the left as you raise the treadmill to the storage position. **Release the storage latch, making sure that it closes fully over the catch.**

To protect the floor or carpet from damage, place a mat under the treadmill. Keep the treadmill out of direct sunlight. Do not leave the treadmill in the storage position in temperatures above 85° Fahrenheit.

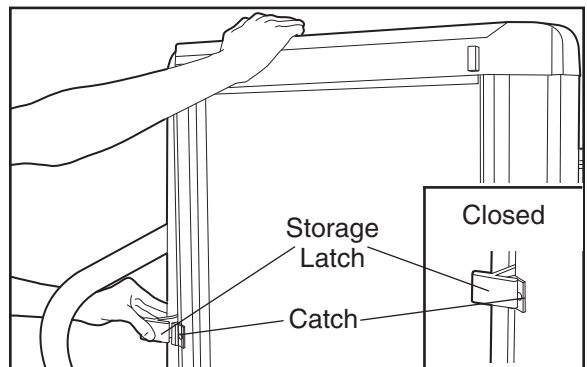

HOW TO MOVE THE TREADMILL

Before moving the treadmill, convert the treadmill to the storage position as described above. **Make sure that the storage latch is closed fully over the catch.**

1. Hold the handrails as shown and place one foot against a wheel. **Do not hold or push on the book holder or the book holder may be damaged.**
2. Tilt the treadmill back until it rolls freely on the front wheels. Carefully move the treadmill to the desired location. **Never move the treadmill without tipping it back. To reduce the risk of injury, use extreme caution while moving the treadmill. Do not attempt to move the treadmill over an uneven surface.**
3. Place one foot on the base, and carefully lower the treadmill until it is resting in the storage position.

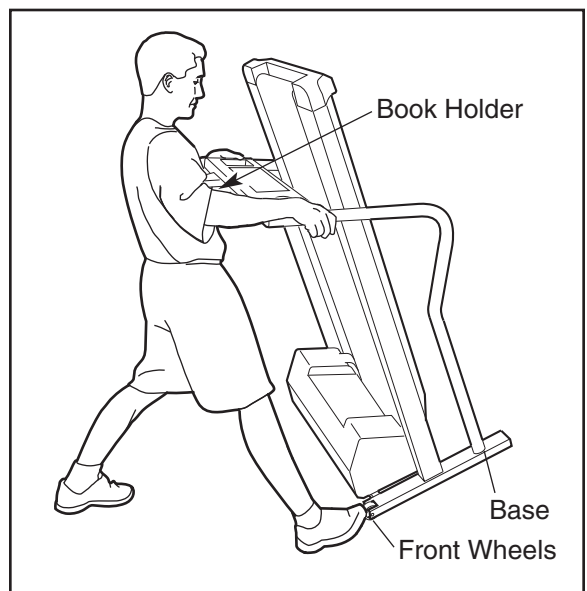

HOW TO LOWER THE TREADMILL FOR USE

1. Hold the upper end of the treadmill with your right hand as shown. Using your left thumb, press the storage latch and hold it. Pivot the treadmill until the frame is past the storage latch.

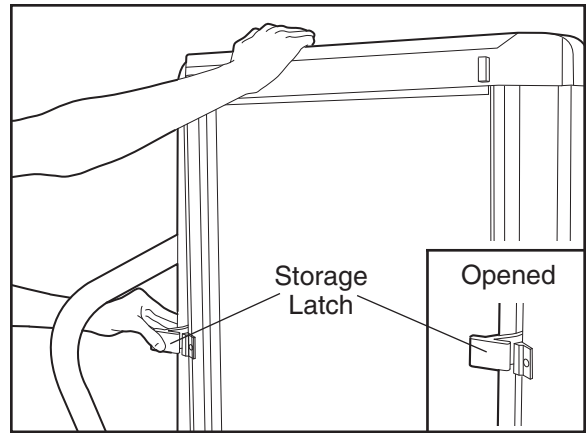

2. Hold the treadmill firmly with both hands, and lower the treadmill to the floor. **Caution: To decrease the possibility of injury, bend your legs and keep your back straight.**

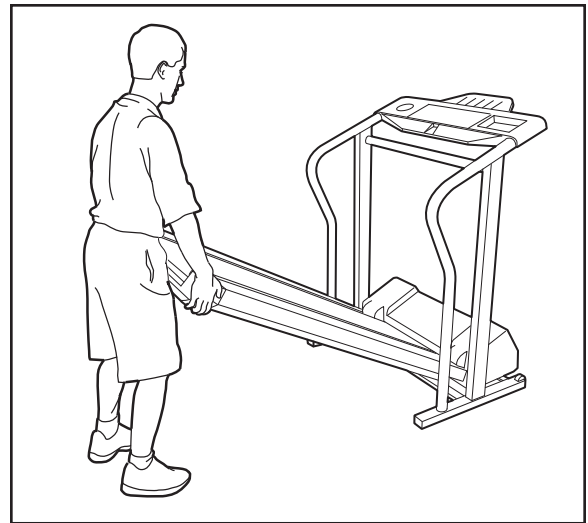

MAINTENANCE AND TROUBLE-SHOOTING

Most treadmill problems can be solved by following the steps below. Find the symptom that applies, and follow the steps listed. If further assistance is needed, please call our Customer Service Department toll-free at 1-800-999-3756, Monday through Friday, 6 a.m. until 6 p.m. Mountain Time (excluding holidays).

PROBLEM: The power does not turn on

SOLUTION: a. Make sure that the power cord is plugged into a surge protector, and that the surge protector is plugged into a properly grounded outlet. (See HOW TO PLUG IN THE POWER CORD on page 7.) Use only a UL-listed surge protector, rated at 15 amps, with a 14-gauge cord of five feet or less in length.

b. After the power cord has been plugged in, make sure that the key is fully inserted into the console. (See step 1 on page 8.)

c. Check the circuit breaker located on the treadmill near the power cord. If the switch protrudes as shown, the circuit breaker has tripped. To reset the circuit breaker, wait for five minutes and then press the switch back in.

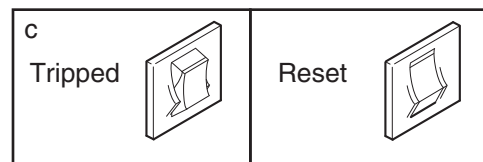

PROBLEM: The power turns off during use

SOLUTION: a. Check the circuit breaker located on the treadmill frame near the power cord (see 1. c. above). If the circuit breaker has tripped, wait for five minutes and then press the switch back in.

b. Make sure that the power cord is plugged in.

c. Remove the key from the console. Reinsert the key fully into the console. (See step 1 on page 8.)

d. If the treadmill still will not run, please call our Customer Service Department, toll-free.

PROBLEM: The displays of the console do not function properly

SOLUTION: a. Remove the key from the console and **UNPLUG THE POWER CORD**. Next, remove the screws from the hood and carefully remove the hood. Locate the Reed Switch (97) and the Magnet (9) on the left side of the Pulley (10). Turn the Pulley until the Magnet is aligned with the Reed Switch. **Check the gap between the Magnet and the Reed Switch—it should be about 1/8”**. If necessary, loosen the Screw (43) and move the Reed Switch slightly. Retighten the Screw. Reattach the hood and run the treadmill for a few minutes to check for a correct speed reading.

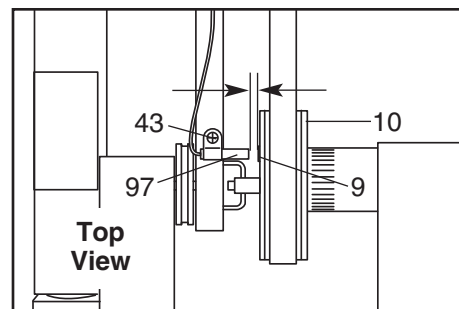

PROBLEM: The walking belt slows when walked on

SOLUTION: a. Use only a UL-listed surge protector, rated at 15 amps, with a 14-gauge cord of five feet or less in length.

b. If the walking belt is overtightened, treadmill performance may decrease and the walking belt may be permanently damaged. Remove the key and **UNPLUG THE POWER CORD**. Using the allen wrench, turn both rear roller adjustment bolts counterclockwise, 1/4 of a turn. When the walking belt is properly tightened, you should be able to lift each side of the walking belt 2 to 3 inches off the walking platform. Be careful to keep the walking belt centered. Plug in the power cord, insert the key and run the treadmill for a few minutes. Repeat until the walking belt is properly tightened.

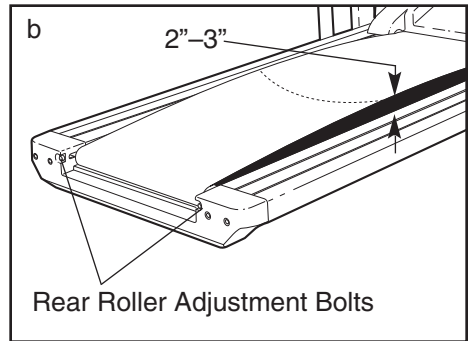

c. If the walking belt still slows when walked on, please call our Customer Service Department, toll-free.

PROBLEM: The walking belt is off-center

SOLUTION: a. If the walking belt has shifted to the left, first remove the key and **UNPLUG THE POWER CORD**. Using the allen wrench, turn the left rear roller adjustment bolt clockwise, and the right bolt counterclockwise, 1/4 of a turn each. Be careful not to overtighten the walking belt. Plug in the power cord, insert the key and run the treadmill for a few minutes. Repeat until the walking belt is centered.

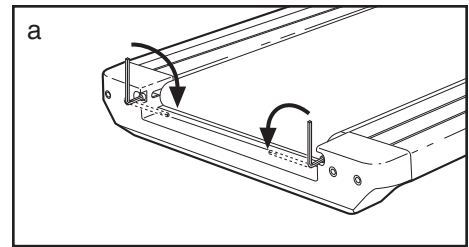

b. If the walking belt has shifted to the right, first remove the key and **UNPLUG THE POWER CORD**. Using the allen wrench, turn the left rear roller adjustment bolt counterclockwise, and the right bolt clockwise, 1/4 of a turn each. Be careful not to overtighten the walking belt. Plug in the power cord, insert the key and run the treadmill for a few minutes. Repeat until the walking belt is centered.

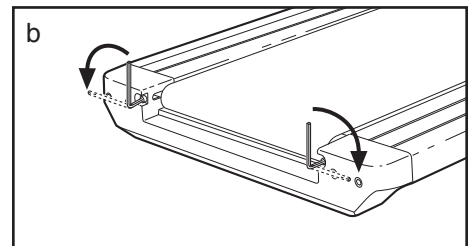

PROBLEM: The walking belt slips when walked on

SOLUTION: a. If the walking belt slips when walked on, first remove the key and **UNPLUG THE POWER CORD**. Using the allen wrench, turn both rear roller adjustment bolts clockwise, 1/4 of a turn. When the walking belt is correctly tightened, you should be able to lift each side of the walking belt 2 to 3 inches off the walking platform. Be careful to keep the walking belt centered. Plug in the power cord, insert the key and carefully walk on the treadmill for a few minutes. Repeat until the walking belt is properly tightened.

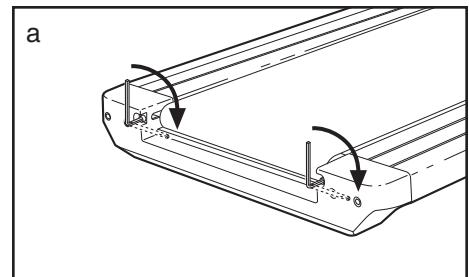

CONDITIONING GUIDELINES

⚠️ WARNING: Before beginning this or any exercise program, consult your physician. This is especially important for individuals over the age of 35 or individuals with pre-existing health problems.

The pulse sensor is not a medical device. Various factors, including your movement, may affect the accuracy of heart rate readings. The sensor is intended only as an exercise aid in determining heart rate trends in general.

The following guidelines will help you to plan your exercise program. Remember—these are general guidelines only. For more detailed exercise information, obtain a reputable book or consult your physician.

EXERCISE INTENSITY

Whether your goal is to burn fat or to strengthen your cardiovascular system, the key to achieving the desired results is to exercise with the proper intensity. The proper intensity level can be found by using your heart rate as a guide. The chart below shows recommended heart rates for fat burning and aerobic exercise.

HEART RATE TRAINING ZONES							
AEROBIC	165	155	145	140	130	125	115
MAX FAT BURN	145	138	130	125	118	110	103
FAT BURN	125	120	115	110	105	95	90
Age	20	30	40	50	60	70	80

To find the proper heart rate for you, first find your age near the bottom of the chart (ages are rounded off to the nearest ten years). Next, find the three numbers above your age. The three numbers define your “training zone.” The lower two numbers are recommended heart rates for fat burning; the higher number is the recommended heart rate for aerobic exercise.

To measure your heart rate during exercise, use the pulse sensor on the console. If your heart rate is too high or too low, adjust the speed and incline of the treadmill.

Fat Burning

To burn fat effectively, you must exercise at a relatively low intensity level for a sustained period of time. During the first few minutes of exercise, your body uses easily accessible *carbohydrate calories* for energy. Only after the first few minutes does your body begin to use stored *fat calories* for energy. If your goal is to burn fat, adjust the speed and incline of the treadmill until your heart rate is near the lowest number in your training zone. It may also be helpful to set the speed control on the console to FAT BURN.

Aerobic Exercise

If your goal is to strengthen your cardiovascular system, your exercise must be “aerobic.” Aerobic exercise is activity that requires large amounts of oxygen for prolonged periods of time. This increases the demand on the heart to pump blood to the muscles, and on the lungs to oxygenate the blood. For aerobic exercise, adjust the speed and incline of the treadmill until your heart rate is near the middle of your training zone. It may also be helpful to set the speed control on the console to AEROBIC.

High Performance Athletic Conditioning

If your goal is high performance athletic conditioning, adjust the speed and incline of the treadmill until your heart rate is near the highest number in your training zone, or set the speed control on the console to PERFORMANCE. Note: During the first few weeks of your exercise program, keep your heart rate near the low end of your training zone.

WORKOUT GUIDELINES

Each workout should include the following three parts:

A Warm-up—Start each workout with 5 to 10 minutes of stretching and light exercise. A proper warm-up increases your body temperature, heart rate, and circulation in preparation for exercise.

Training Zone Exercise—After warming up, increase the intensity of your exercise until your pulse is in your training zone for 20 to 60 minutes. (During the first few weeks of your exercise program, do not keep your pulse in your training zone for longer than 20 minutes.) Breathe regularly and deeply as you exercise—never hold your breath.

A Cool-down—Finish each workout with 5 to 10 minutes of stretching to cool down. This will increase the flexibility of your muscles and will help prevent post-exercise problems.

Exercise Frequency

To maintain or improve your condition, complete three workouts each week, with at least one day of rest between workouts. After a few months, you may complete up to five workouts each week if desired. The key to success is to make exercise a regular and enjoyable part of your everyday life.

SUGGESTED STRETCHES

The correct form for several basic stretches is shown at the right. Move slowly as you stretch—never bounce.

1. Toe Touch Stretch

Stand with your knees bent slightly and slowly bend forward from your hips. Allow your back and shoulders to relax as you reach down toward your toes as far as possible. Hold for 15 counts, then relax. Repeat 3 times. Stretches: Hamstrings, back of knees, and back.

2. Hamstring Stretch

Sit with one leg extended. Bring the sole of the opposite foot toward you and rest it against the inner thigh of your extended leg. Reach toward your toes as far as possible. Hold for 15 counts, then relax. Repeat 3 times for each leg. Stretches: Hamstrings, lower back, and groin.

3. Calf/Achilles Stretch

With one leg in front of the other, reach forward and place your hands against a wall. Keep your back leg straight and your back foot flat on the floor. Bend your front leg, lean forward and move your hips toward the wall. Hold for 15 counts, then relax. Repeat 3 times for each leg. To cause further stretching of the achilles tendons, bend your back leg as well. Stretches: Calves, achilles tendons, and ankles.

4. Quadriceps Stretch

With one hand against a wall for balance, reach back and grasp one foot with your other hand. Bring your heel as close to your buttocks as possible. Hold for 15 counts, then relax. Repeat 3 times for both legs. Stretches: Quadriceps and hip muscles.

5. Inner Thigh Stretch

Sit with the soles of your feet together and your knees outward. Pull your feet toward your groin area as far as possible. Hold for 15 counts, then relax. Repeat 3 times. Stretches: Quadriceps and hip muscles.

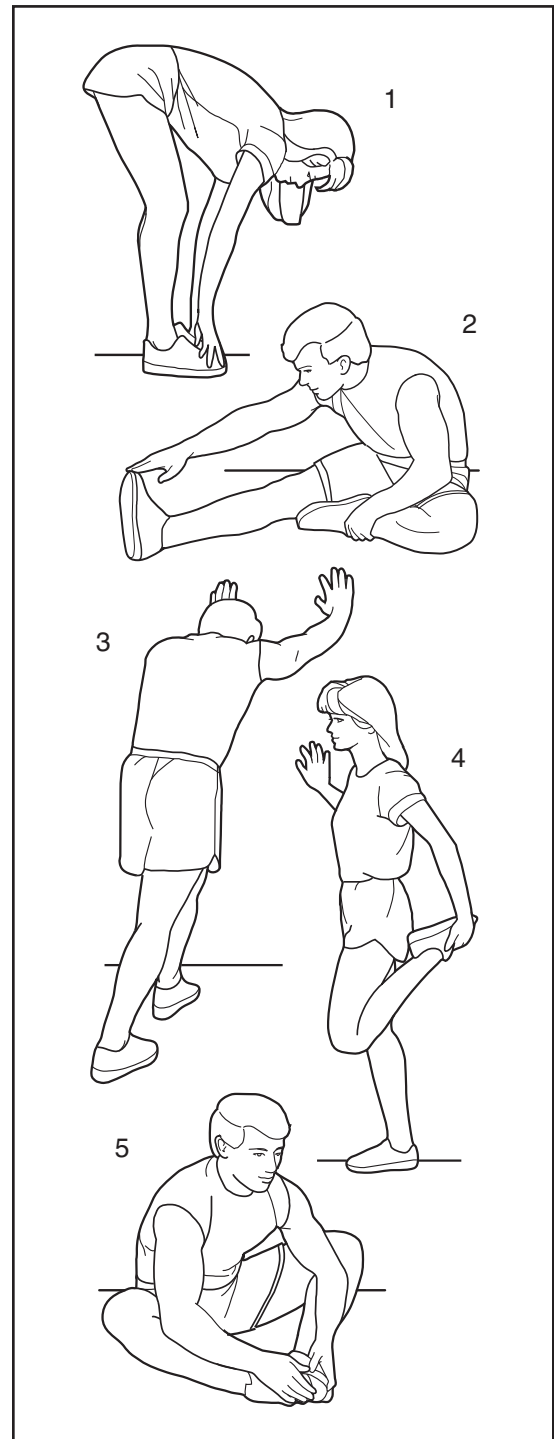

PART LIST—Model No. PFTL58590

R0100A

Key No.	Qty.	Description	Key No.	Qty.	Description
1	1	Frame	59	2	Extension Leg
2	4	Book Rack Screw	60	1	Left Handrail
3	1	Latch Catch	61	2	Extension Leg Endcap
4	1	Rear Roller	62	1	Right Handrail
5	2	Roller Guard	63	1	Rear Endcap
6	2	Center Platform Screw	64*	1	Console Assembly
7	2	Foot Rail	65	2	Front Wheel
8	1	Walking Platform	66	1	Motor/Pulley/Flywheel/Fan
9	1	Magnet	67	1	Motor Pivot Bolt
10	1	Front Roller/Pulley	68	1	Motor Tension Nut
11	1	Walking Belt	69	3	Motor Star Washer
12	9	Electronics Screw	70	1	Motor Tension Washer
13	2	Wire Clip	71	1	Motor Tension Bolt
14	1	Latch Warning Decal	72	1	Motor Belt
15	11	Belly Pan Screw	73	1	Pulley/Flywheel/Fan
16	1	Belly Pan	74	1	Motor
17	2	Center Isolator	75	5	8" Wire Tie
18	2	Frame Pivot Bolt	76	2	Belt Guide
19	8	Hood Bracket Screw	77	1	Endcap Foot (left)
20	1	Hood	78	10	Small Screw
21	1	Key/Clip	79	2	Rear Roller Adj. Bolt
22	1	Book Rack	80	5	Hood Anchor
23	2	Battery Cover	81	1	Circuit Breaker
24	4	Long Console Screw	82	1	Power Cord
25	1	Incline Control	83	1	Power Cord Grommet
26	1	Speed Control	84	1	Outlet Bracket Plug
27	1	Speed Potentiometer	85	1	Outlet Bracket
28	10	Screw	86	5	Hood Bracket
29	4	Rear Platform Screw	87	2	Spacer
30	4	Handrail Bolt	88	1	4.5" Spacer
31	2	Frame Pivot Washer	89	1	Small Catch Screw
32	1	Upright/Base	90	1	Front Roller Nut
33	2	Latch Spacer	91	1	Controller
34	1	Latch	92	1	Front Roller Adj. Bolt
35	1	Wire Harness	93	1	Incline Leg
36	1	Grommet	94	1	Choke Plate
37	1	Incline Motor Nut	95	1	Choke
38	4	Cage Nut	96	1	Reed Switch Clip
39	2	Incline Leg Pivot Bolt	97	1	Reed Switch
40	7	Adj. Washer/Handrail Washer	98	8	Belly Pan Fastener/Clip Screw
41	6	Nut	99	1	Front Belly Pan
42	2	Outlet Bracket Star Washer	100	1	Ground Wire
43	3	Belly Pan Screw/Reed Switch Screw	101	1	Front Roller Adj. Nut
44	1	Incline Motor Spacer	102	1	Allen Wrench
45	1	Incline Motor	103	1	Endcap Plug
46	1	Console Base	104	6	Endcap Fastener
47	1	Incline Stop Bracket	105	1	Endcap Foot (Right)
48	1	Incline Bolt	106	4	Endcap Bolt
49	1	Shock	107	5	Releasable Tie
50	1	Incline Cover	108	4	Plastic Isolator
51	1	Cotter Pin	#	1	8" Black Wire, Male/Female
52	1	Clevis Pin	#	1	4" Black Wire, 2 Female
53	2	Wheel Bolt	#	1	8" White Wire, Pig Tail
54	5	Base Pad Screw	#	1	8" Blue Wire, Pig Tail
55	4	Base Pad	#	1	User's Manual
56	2	Rear Isolator Nut			
57	2	Extension Leg Screw			
58	4	Isolator Nut			

* Includes all parts shown in the box

These parts are not illustrated

EXPLODED DRAWING—Model No. PFTL58590

R0100A

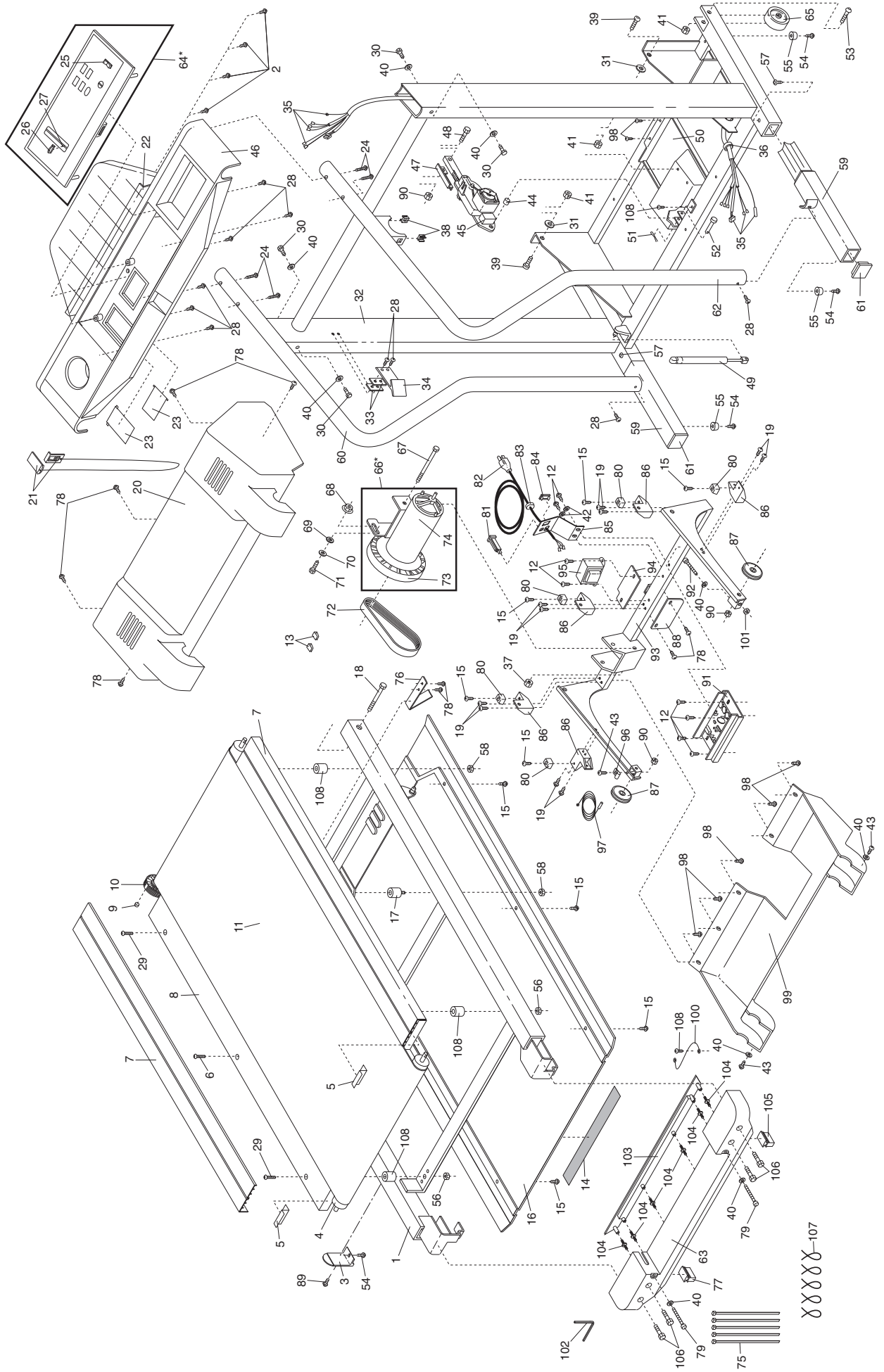

XXXX-107

ORDERING REPLACEMENT PARTS

To order replacement parts, call our Customer Service Department toll-free at 1-800-999-3756, Monday through Friday, 6 a.m. until 6 p.m. Mountain Time (excluding holidays). When ordering parts, please be prepared to give the following information:

- The MODEL NUMBER OF THE PRODUCT (PFTL58590)
- The NAME OF THE PRODUCT (PROFORM® 525C treadmill)
- The SERIAL NUMBER OF THE PRODUCT (see the front cover of this manual)
- The KEY NUMBER AND DESCRIPTION OF THE PART(S) (see the EXPLODED DRAWING and PART LIST attached to the center of this manual).

If possible, place the treadmill near your telephone for easy reference when calling.

LIMITED WARRANTY

ICON Health & Fitness, Inc. (ICON), warrants this product to be free from defects in workmanship and material, under normal use and service conditions, for a period of ninety (90) days from the date of purchase. This warranty extends only to the original purchaser. ICON's obligation under this warranty is limited to replacing or repairing, at ICON's option, the product at one of its authorized service centers. All products for which warranty claim is made must be received by ICON at one of its authorized service centers with all freight and other transportation charges prepaid, accompanied by sufficient proof of purchase. All returns must be pre-authorized by ICON. This warranty does not extend to any product or damage to a product caused by or attributable to freight damage, abuse, misuse, improper or abnormal usage or repairs not provided by an ICON authorized service center, to products used for commercial or rental purposes, or to products used as store display models. No other warranty beyond that specifically set forth above is authorized by ICON.

ICON is not responsible or liable for indirect, special or consequential damages arising out of or in connection with the use or performance of the product or damages with respect to any economic loss, loss of property, loss of revenues or profits, loss of enjoyment or use, costs of removal, installation or other consequential damages of whatsoever nature. Some states do not allow the exclusion or limitation of incidental or consequential damages. Accordingly, the above limitation may not apply to you.

The warranty extended hereunder is in lieu of any and all other warranties and any implied warranties of merchantability or fitness for a particular purpose is limited in its scope and duration to the terms set forth herein. Some states do not allow limitations on how long an implied warranty lasts. Accordingly, the above limitation may not apply to you.

This warranty gives you specific legal rights. You may also have other rights which vary from state to state.

ICON HEALTH & FITNESS, INC., 1500 S. 1000 W., LOGAN, UT 84321-9813