

PRO-FORM® 6.0 GSX

Model No. PFTL51105.1

Serial No. _____

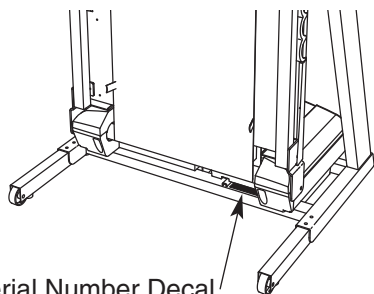

Serial Number Decal

USER'S MANUAL

QUESTIONS?

As a manufacturer, we are committed to providing complete customer satisfaction. If you have questions, or if parts are damaged or missing, PLEASE CONTACT OUR CUSTOMER SERVICE DEPARTMENT DIRECTLY.

CALL TOLL-FREE:

1-888-533-1333

Mon.-Fri., 6 a.m.-6 p.m. MST

ON THE WEB:

www.proformservice.com

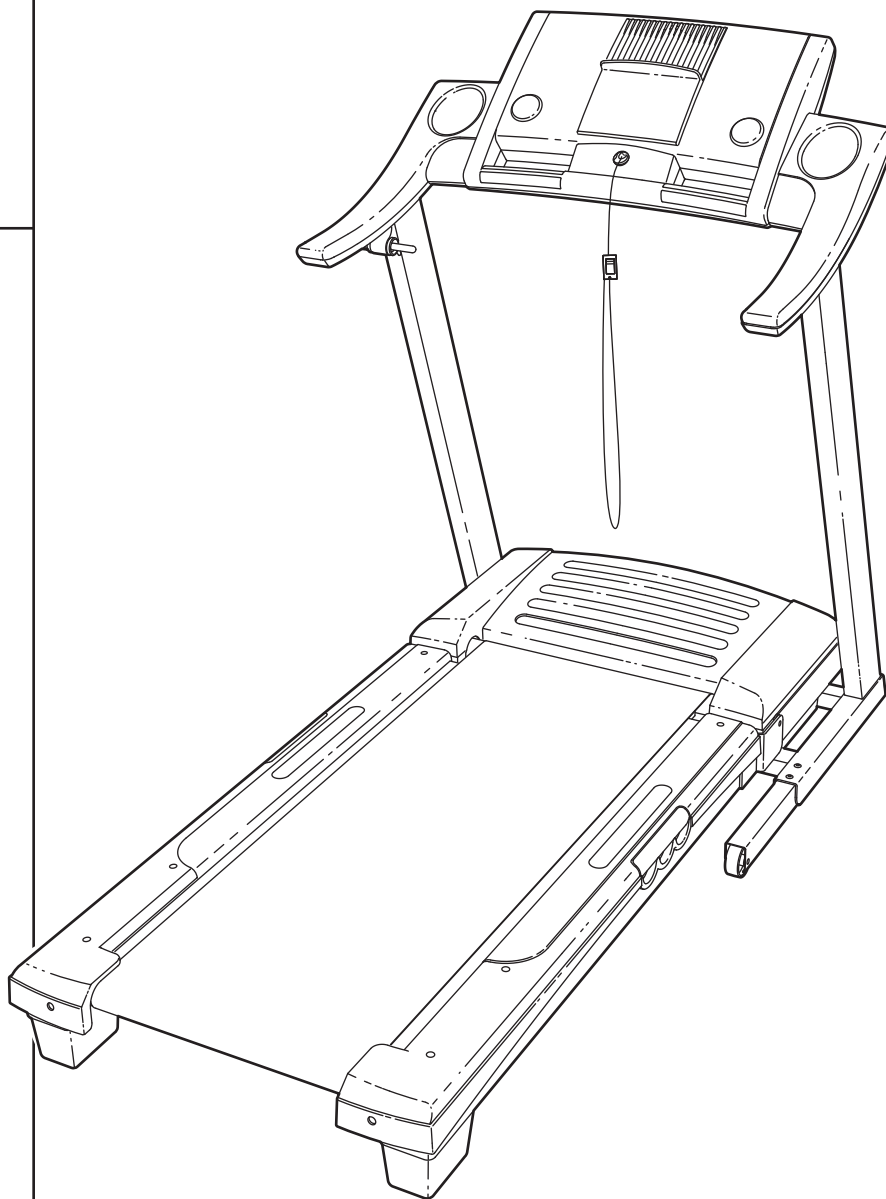

CAUTION

Read all precautions and instructions in this manual before using this equipment. Save this manual for future reference.



Visit our website at

www.proform.com

new products, prizes,
fitness tips, and much more!

PRO-FORM[®] 6.0 **GSX**

TABLE OF CONTENTS

IMPORTANT PRECAUTIONS3
BEFORE YOU BEGIN5
ASSEMBLY6
OPERATION AND ADJUSTMENT9
HOW TO FOLD AND MOVE THE TREADMILL17
TROUBLESHOOTING19
CONDITIONING GUIDELINES21
PART LIST23
ORDERING REPLACEMENT PARTSBack Cover
LIMITED WARRANTYBack Cover

Note: An EXPLODED DRAWING is attached in the center of this manual.

IMPORTANT PRECAUTIONS

⚠ WARNING: To reduce the risk of burns, fire, electric shock, or injury to persons, read the following important precautions and information before operating the treadmill.

1. It is the responsibility of the owner to ensure that all users of this treadmill are adequately informed of all warnings and precautions.
2. Use the treadmill only as described.
3. Place the treadmill on a level surface, with at least eight feet of clearance behind it and two feet on each side. Do not place the treadmill on any surface that blocks air openings. To protect the floor or carpet from damage, place a mat under the treadmill.
4. Keep the treadmill indoors, away from moisture and dust. Do not put the treadmill in a garage or covered patio, or near water.
5. Do not operate the treadmill where aerosol products are used or where oxygen is being administered.
6. Keep children under the age of 12 and pets away from the treadmill at all times.
7. The treadmill should be used only by persons weighing 300 pounds or less.
8. Never allow more than one person on the treadmill at a time.
9. Wear appropriate exercise clothes when using the treadmill. Do not wear loose clothes that could become caught in the treadmill. Athletic support clothes are recommended for both men and women. *Always wear athletic shoes. Never use the treadmill with bare feet, wearing only stockings, or in sandals.*
10. When connecting the power cord (see page 9), plug the power cord into a surge suppressor (not included) and plug the surge suppressor into a grounded circuit capable of carrying 15 or more amps. No other appliance should be on the same circuit. Do not use an extension cord.
11. Use only a single-outlet surge suppressor that meets all of the specifications described on page 9. To purchase a surge suppressor, see your local PROFORM dealer or call the toll-free telephone number on the front cover of this manual and order part number 146148, or see your local electronics store.
12. Failure to use a properly functioning surge suppressor could result in damage to the control system of the treadmill. If the control system is damaged, the walking belt may change speed, accelerate, or stop unexpectedly, which may result in a fall and serious injury.
13. Keep the power cord and the surge suppressor away from heated surfaces.
14. Never move the walking belt while the power is turned off. Do not operate the treadmill if the power cord or plug is damaged, or if the treadmill is not working properly. (See TROUBLESHOOTING on page 19 if the treadmill is not working properly.)
15. Never start the treadmill while you are standing on the walking belt. Always hold the handrails while using the treadmill.
16. The treadmill is capable of high speeds. Adjust the speed in small increments to avoid sudden jumps in speed.
17. The pulse sensor is not a medical device. Various factors, including the user's movement, may affect the accuracy of heart rate readings. The pulse sensor is intended only as an exercise aid in determining heart rate trends in general.
18. Never leave the treadmill unattended while it is running. Always remove the key, unplug the power cord, and switch the reset/off circuit breaker to the off position when the treadmill is not in use. (See the drawing on page 5 for the location of the circuit breaker.)
19. Do not attempt to raise, lower, or move the treadmill until it is properly assembled. (See ASSEMBLY on page 6, and HOW TO FOLD AND MOVE THE TREADMILL on page 17.) You must be able to safely lift 45 pounds (20 kg) to raise, lower, or move the treadmill.

20. When folding or moving the treadmill, make sure that the storage latch is fully closed.

21. Inspect and properly tighten all parts of the treadmill regularly.

22. Never insert any object into any opening.

23. **DANGER:** Always unplug the power cord immediately after use, before cleaning the

treadmill, and before performing the maintenance and adjustment procedures described in this manual. Never remove the motor hood unless instructed to do so by an authorized service representative. Servicing other than the procedures in this manual should be performed by an authorized service representative only.

24. This treadmill is intended for in-home use only. Do not use this treadmill in a commercial, rental, or institutional setting.

⚠ WARNING: Before beginning this or any exercise program, consult your physician. This is especially important for persons over the age of 35 or persons with pre-existing health problems. Read all instructions before using. ICON assumes no responsibility for personal injury or property damage sustained by or through the use of this product.

SAVE THESE INSTRUCTIONS

The decals shown here have been placed on your treadmill. If a decal is missing, or if it is not legible, please call the toll-free telephone number on the front cover of this manual and order a free replacement decal. Apply the decal in the location shown.

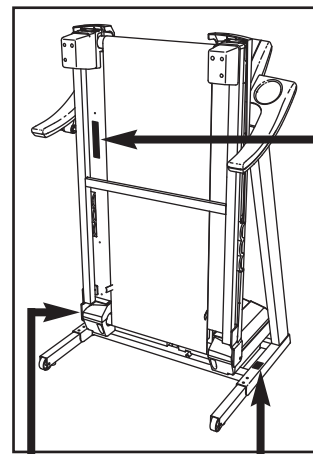

⚠ CAUTION
KEEP HANDS AND FEET AWAY FROM THIS AREA WHILE THE TREADMILL IS IN OPERATION.

⚠ WARNING:
Protect yourself and others from risk of serious injury. Read the user's manual and :

- Stand only on the side rails when starting or stopping treadmill.
- Change speed in small increments.
- Hold handrails to prevent falling, and always wear the safety clip while operating treadmill.
- Stop if you feel faint, dizzy, or short of breath.
- Fully engage storage latch before treadmill is moved or stored.
- Reduce incline to its lowest level before folding treadmill into storage position.
- Never allow children on or around treadmill.
- Remove key when not in use.
- Keep clothing, fingers, and hair away from moving belt.
- Never try to adjust or fix the belt while it is moving.
- Always wear athletic shoes while operating treadmill.

BEFORE YOU BEGIN

Thank you for selecting the revolutionary PROFORM® 6.0 GSX treadmill. The 6.0 GSX treadmill offers an impressive array of features designed to make your workouts at home more enjoyable and effective. And when you're not exercising, the unique 6.0 GSX treadmill can be folded up, requiring less than half the floor space of other treadmills.

For your benefit, read this manual carefully before you use the treadmill. If you have questions after reading this manual, please see the front cover of this manual. To help us assist you, note the product model

number and serial number before calling. The model number of the treadmill is PFTL51105.1. The serial number can be found on a decal attached to the treadmill (see the front cover of this manual for the location).

To avoid a registration fee for any service needed under warranty, you must register the treadmill at www.proformservice.com/registration.

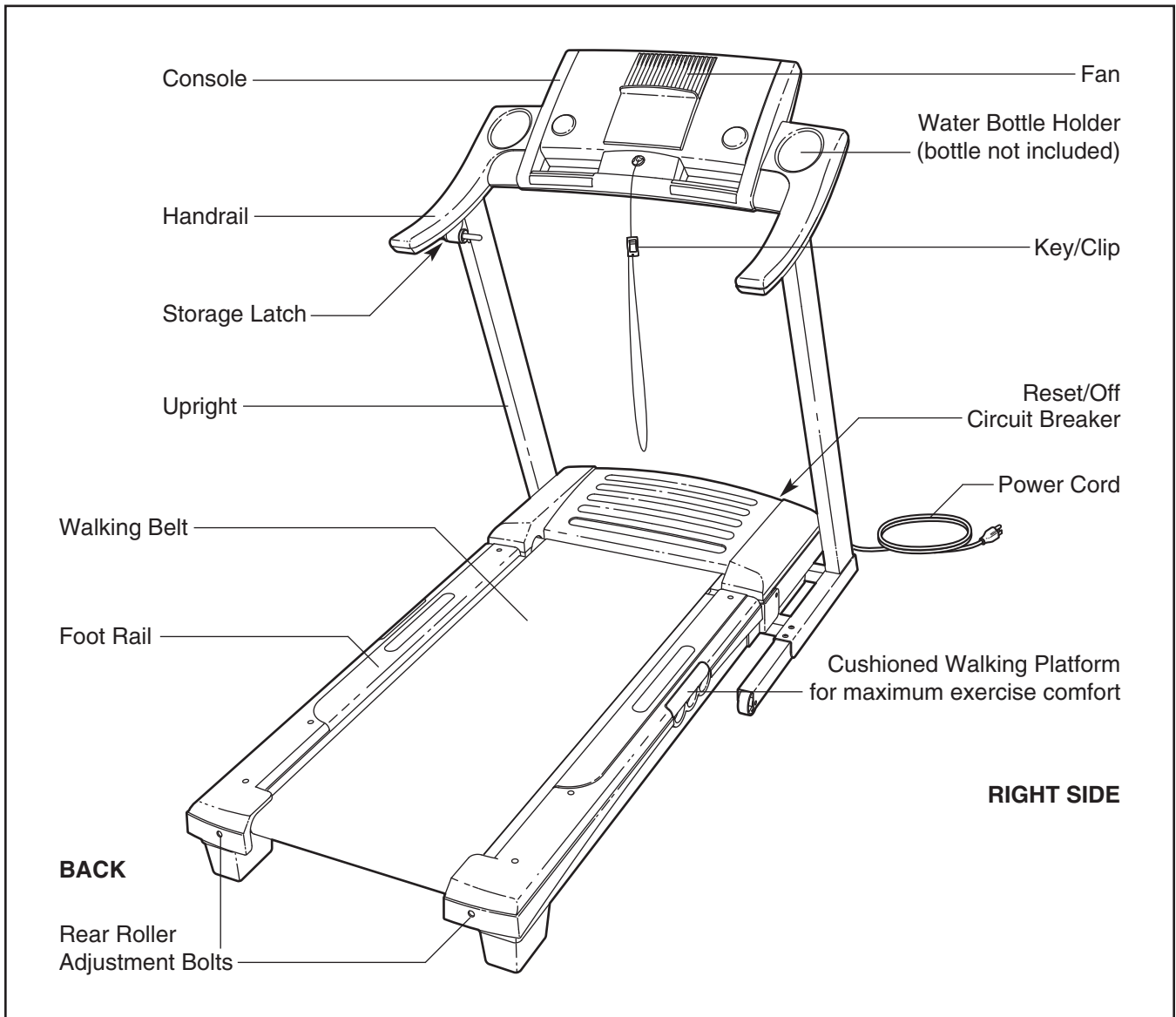

Before reading further, please review the drawing below and familiarize yourself with the labeled parts.



ASSEMBLY

To hire an authorized service technician to assemble the treadmill, call toll-free 1-800-445-2480.

Assembly requires two persons. Set the treadmill in a cleared area and remove all packing materials. Do not dispose of the packing materials until assembly is completed. Note: The underside of the treadmill walking belt is coated with high-performance lubricant. During shipping, a small amount of lubricant may be transferred to the top of the walking belt or the shipping carton. This is a normal condition and does not affect treadmill performance. If there is lubricant on top of the walking belt, simply wipe off the lubricant with a soft cloth and a mild, non-abrasive cleaner.

Assembly requires the included allen wrench  **and your own phillips screwdriver**  **(with a shaft at least 6" long) and wire cutters**  .

Use the drawings below to identify the hardware used during assembly. **Note: If a part is not in the parts bag, check to see if it has been preattached to one of the parts to be assembled.**

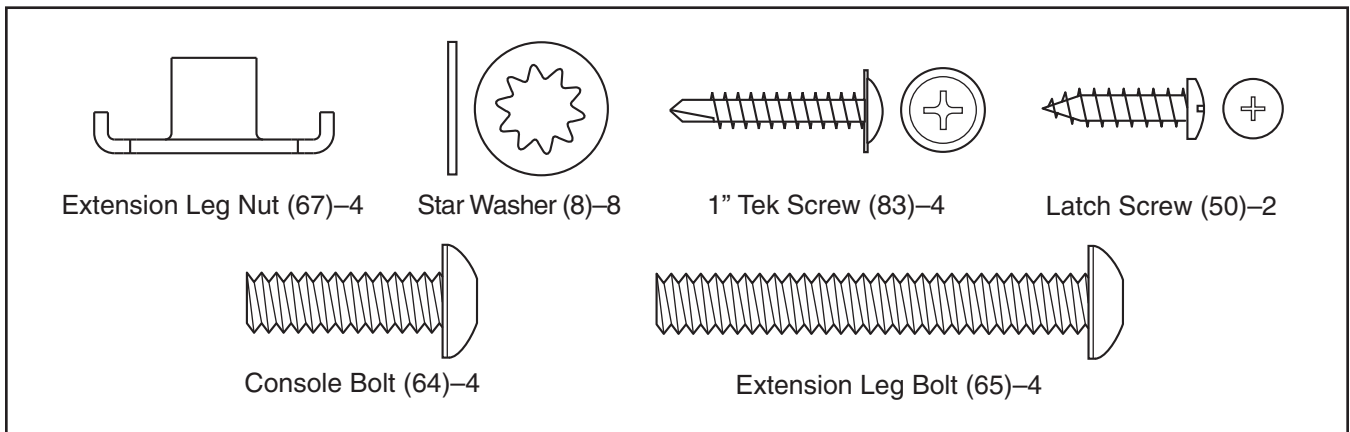

1. Make sure that the power cord is unplugged.

With the help of a second person, carefully tip the treadmill onto its left side as shown. Partially fold the Frame (58) so the treadmill is more stable. **Do not fully fold the treadmill until it is completely assembled.**

Insert an Extension Leg (89) into the base of the Uprights (84) as shown. Next, insert two Extension Leg Nuts (67) into the bottom of the Extension Leg. Hold the Extension Leg Nuts in place and insert two Extension Leg Bolts (65) with Star Washers (8) into the top of the Extension Leg. Firmly tighten the Extension Leg Bolts into the Extension Leg Nuts. Attach the other Extension Leg in the same way. With the help of a second person, carefully tip the treadmill onto the other side and attach the other Extension Leg.

Attach four Base Pads (82) to the base of the Uprights (84) with four 1" Tek Screws (83) (only two are shown).

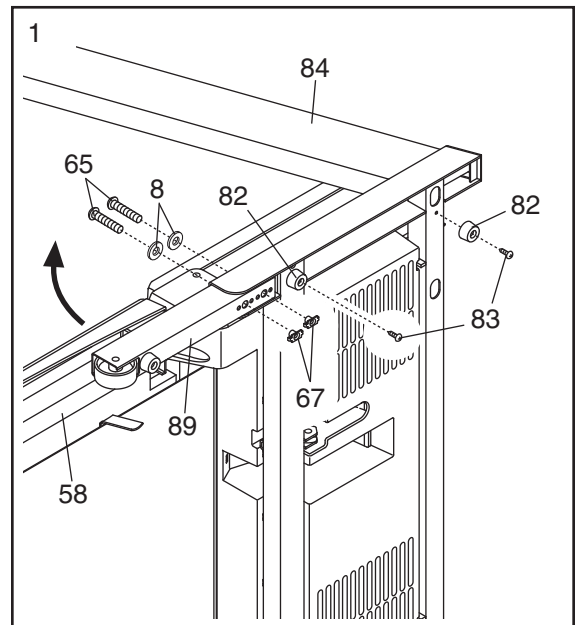

2. With the help of a second person, carefully raise the Uprights (84) to a vertical position.

Have the second person hold the console assembly near the Uprights (84) as shown. Look under the console assembly and locate the Console Wire Harness (78).

Cut the plastic ties securing the Upright Wire Harness (77) to the right Upright (84). Next, connect the Upright Wire Harness to the Console Wire Harness (78). **Make sure to connect the connectors properly (see the inset drawing). The connectors should slide together easily and snap into place.** If the connectors do not slide together easily and snap into place, turn one connector and then try again. **IF THE CONNECTORS ARE NOT CONNECTED PROPERLY, THE CONSOLE MAY BE DAMAGED WHEN THE POWER IS TURNED ON.**

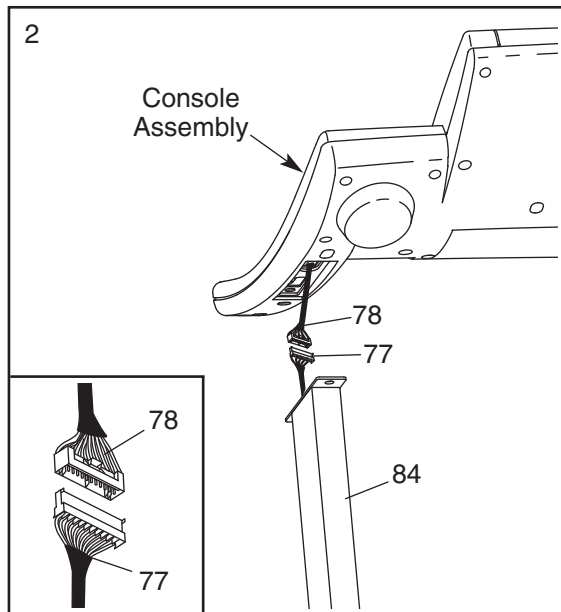

3. Insert the Wire Harnesses (77, 78) down into the right Upright (84).

Set the console assembly on the Uprights (84). **Be careful to avoid pinching the Wire Harnesses (77, 78).** While a second person holds the console assembly, attach it with four Console Bolts (64) and four Star Washers (8) as shown; **start all four Console Bolts and then firmly tighten them.**

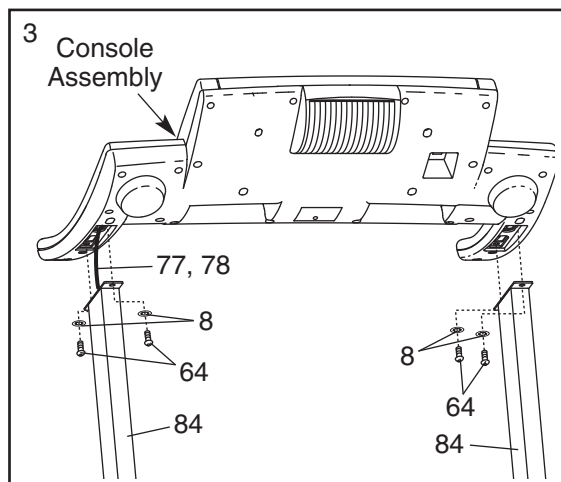

4. Attach the Latch Housing (73) to the left Upright (84) with two Latch Screws (50); **start both Latch Screws and then tighten them. Note: Make sure that the large hole in the Housing is on the indicated side.**

Remove the knob from the pin. Make sure that the collar and the spring are on the pin. (Note: If there are two collars, place one on each side of the spring.) Next, insert the pin into the Latch Housing (73). Then, tighten the knob back onto the pin.

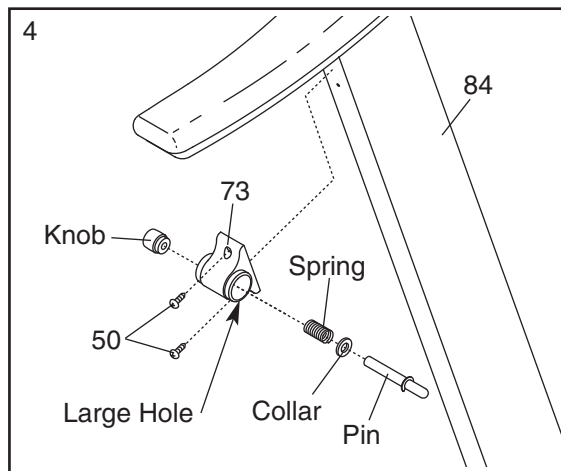

5. **Make sure that all parts are properly tightened before you use the treadmill.** If there are sheets of clear plastic on the treadmill decals, remove the plastic. To protect the floor or carpet, place a mat under the treadmill. Note: Extra hardware may be included. Keep the included allen wrench in a secure place; the large allen wrench is used to adjust the walking belt (see page 20).

If you purchase the optional chest pulse sensor (see page 16), follow the steps below to install the receiver included with the chest pulse sensor.

1. **Make sure that the key is removed from the console and that the power cord is unplugged.**

Remove the indicated Screw (3) and the Access Door (76) from the back of the Console Base (85).

2. Connect the wire on the receiver (A) to the indicated wire extending from the Console Base (85). **Hold the receiver so the small cylinder is oriented as shown and is facing the Console Back.** Attach the receiver to the plastic posts on the Access Door (76) with the two included small screws.
3. **Make sure that no wires are pinched.** Reattach the Access Door (76) with the Screw (3). Discard the other wires included with the receiver.

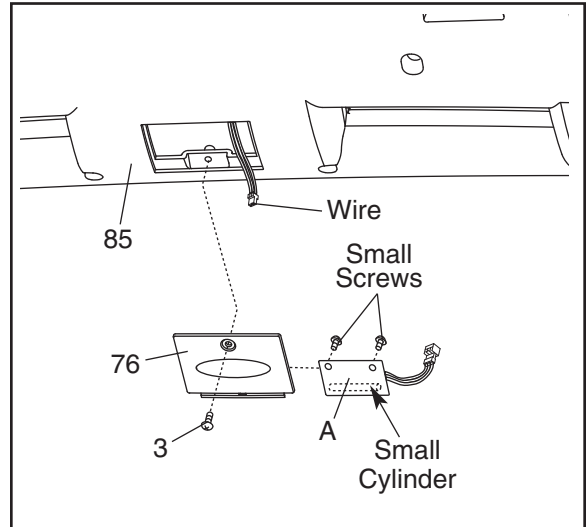

OPERATION AND ADJUSTMENT

THE PRE-LUBRICATED WALKING BELT

Your treadmill features a walking belt coated with high-performance lubricant. **IMPORTANT: Never apply silicone spray or other substances to the walking belt or the walking platform. Such substances will deteriorate the walking belt and cause excessive wear.**

HOW TO PLUG IN THE POWER CORD

⚠ DANGER: Improper connection of the equipment-grounding conductor can result in an increased risk of electric shock. Check with a qualified electrician or serviceman if you are in doubt as to whether the product is properly grounded. Do not modify the plug provided with the product—if it will not fit the outlet, have a proper outlet installed by a qualified electrician.

Your treadmill, like any other type of sophisticated electronic equipment, can be seriously damaged by sudden voltage changes in your home's power. Voltage surges, spikes, and noise interference can result from weather conditions or from other appliances being turned on or off. **To decrease the possibility of your treadmill being damaged, always use a surge suppressor with your treadmill (see drawing 1 at the right).** To purchase a surge suppressor, see your local PROFORM dealer or call the toll-free telephone number on the front cover of this manual and order part number 146148, or see your local electronics store.

Use only a single-outlet surge suppressor that is UL 1449 listed as a transient voltage surge suppressor (TVSS). The surge suppressor must have a UL suppressed voltage rating of 400 volts or less and a minimum surge dissipation of 450 joules. The surge suppressor must be electrically rated for 120 volts AC and 15 amps. There must be a monitoring light on the surge suppressor to indicate whether it is functioning properly. Failure to use a properly functioning surge suppressor could result in damage to the control system of the treadmill. If the control system is damaged, the walking belt may change speed, accelerate or stop unexpectedly, which may result in a fall and serious injury.

This product must be grounded. If it should malfunction or break down, grounding provides a path of least resistance for electric current to reduce the risk of elec-

tric shock. This product is equipped with a cord having an equipment-grounding conductor and a grounding plug. **Plug the power cord into a surge suppressor, and plug the surge suppressor into an appropriate outlet that is properly installed and grounded in accordance with all local codes and ordinances. Important: The treadmill is not compatible with GFCI-equipped outlets.**

This product is for use on a nominal 120-volt circuit, and has a grounding plug that looks like the plug illustrated in drawing 1 below. A temporary adapter that looks like the adapter illustrated in drawing 2 may be used to connect the surge suppressor to a 2-pole receptacle as shown in drawing 2 if a properly grounded outlet is not available.

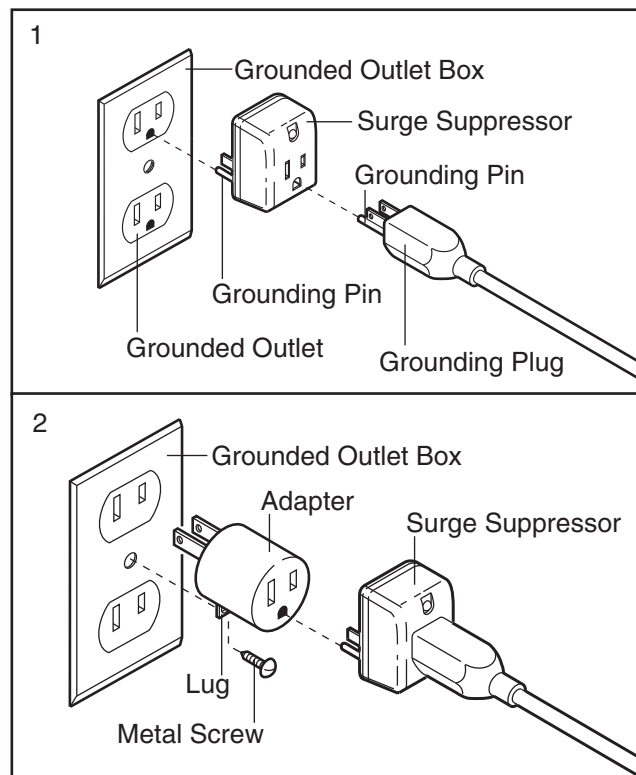

The temporary adapter should be used only until a properly grounded outlet (drawing 1) can be installed by a qualified electrician.

The green-colored rigid ear, lug, or the like extending from the adapter must be connected to a permanent ground such as a properly grounded outlet box cover. Whenever the adapter is used it must be held in place by a metal screw. **Some 2-pole receptacle outlet box covers are not grounded. Contact a qualified electrician to determine if the outlet box cover is grounded before using an adapter.**

CONSOLE DIAGRAM

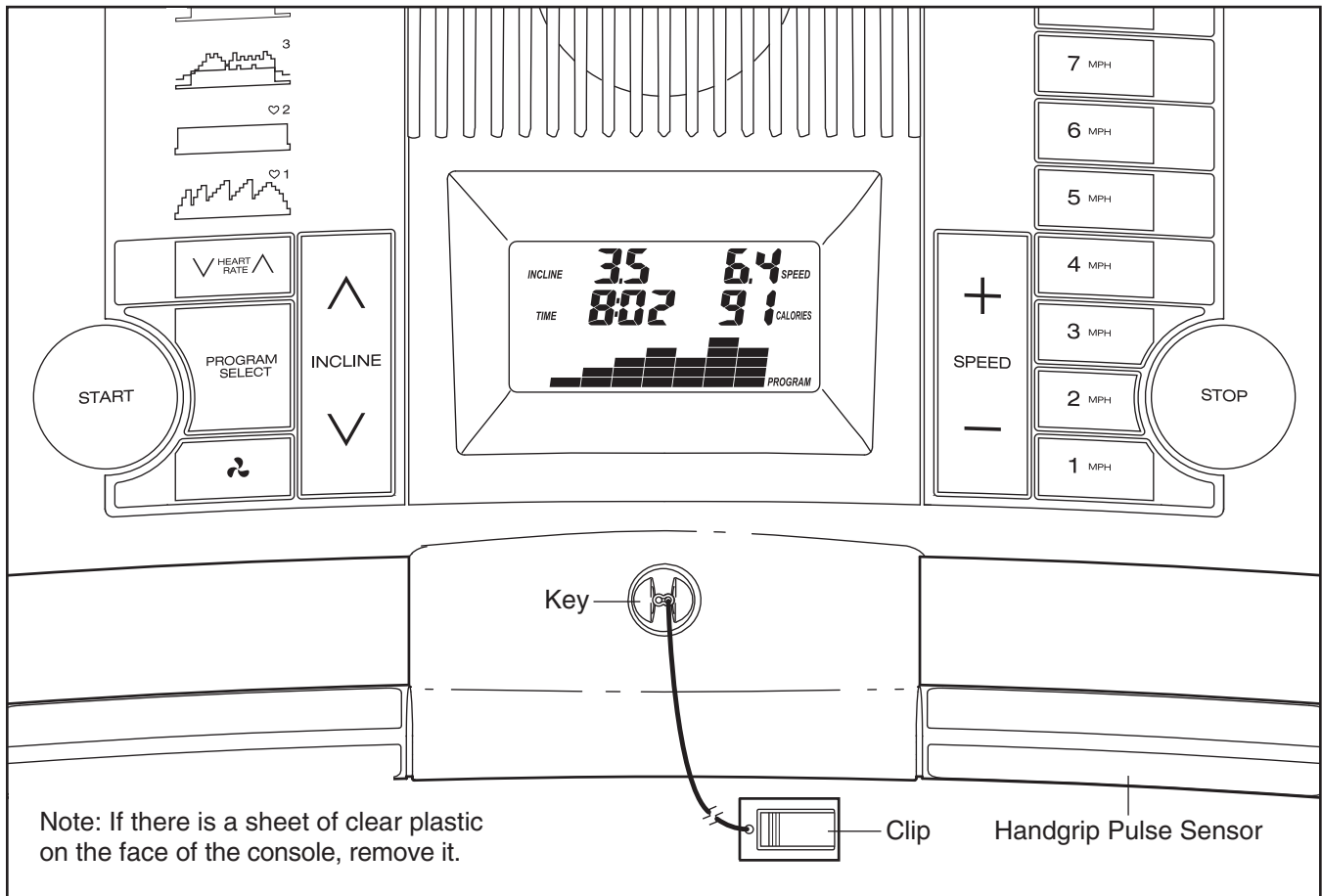

FEATURES OF THE CONSOLE

The treadmill console offers an impressive array of features designed to make your workouts more effective.

When the manual mode of the console is selected, the speed and incline of the treadmill can be changed with the touch of a button. As you exercise, the console will display continuous exercise feedback. You can even measure your heart rate using the built-in handgrip pulse sensor or the optional chest pulse sensor (see page 16).

In addition, the console features four preset programs. Each program automatically controls the speed and incline of the treadmill as it guides you through an effective workout. The console also offers two heart rate programs that control the speed and incline of the treadmill to keep your heart rate near target heart rates during your workouts. Note: You must wear the optional chest pulse sensor to use the heart rate programs.

To use the manual mode of the console, follow the steps beginning on page 11. **To use a preset program**, see page 13. **To use a heart rate program**, see page 14.

HOW TO TURN ON THE POWER

Note: To prevent damage to the walking platform, always wear clean shoes when using the treadmill.

Plug in the power cord (see page 9). Next, locate the reset/off circuit breaker near the power cord. Make sure that the circuit breaker is in the reset position.

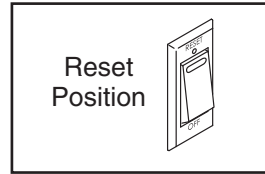

Stand on the foot rails of the treadmill. Find the clip attached to the key (see the drawing on page 10), and slide the clip onto the waistband of your clothes. Next, insert the key into the console. The display will light. **Test the clip by carefully taking a few steps backward until the key is pulled from the console. If the key is not pulled from the console, adjust the position of the clip as needed.**

HOW TO USE THE MANUAL MODE

1 Insert the key into the console.

See HOW TO TURN ON THE POWER above.

2 Select the manual mode.

When the key is inserted, the manual mode will be selected.

If a program has been selected, reselect the manual mode by pressing the Program Select button repeatedly until a track appears in the lower part of the display.

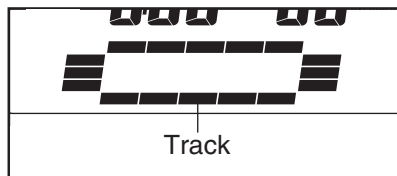

3 Start the walking belt.

To start the walking belt, press the Start button, the Speed increase button, or one of the speed buttons numbered 1 to 10.

If the Start button or the Speed increase button is pressed, the walking belt will begin to move at 1

mph. As you exercise, change the speed of the walking belt as desired by pressing the Speed increase and decrease buttons. Each time a button is pressed, the speed setting will change by 0.1 mph; if a button is held down, the speed setting will change in increments of 0.5 mph. Note: After the buttons are pressed, it may take a moment for the walking belt to reach the selected speed setting.



If one of the speed buttons numbered 1 through 10 is pressed, the walking belt will gradually increase in speed until it reaches the selected speed setting.

To stop the walking belt, press the Stop button. To restart the walking belt, press the Start button, the Speed increase button, or one of the speed buttons numbered 1 through 10.

Note: The first time the treadmill is used, observe the alignment of the walking belt, and align the walking belt if necessary (see page 20).

4 Change the incline of the treadmill as desired.

To change the incline of the treadmill, press the Incline increase and decrease buttons. Each time a button is pressed, the incline will change by 0.5%. Note: After the buttons are pressed, it may take a moment for the treadmill to reach the selected incline setting.

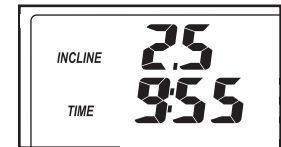

5 Follow your progress with the display.

When the manual mode is selected, the lower part of the display will show a track that

represents 1/4 mile. As you walk or run, the indicators around the track will appear in succession until the entire track appears. The track will then disappear and the indicators will again begin to appear in succession.

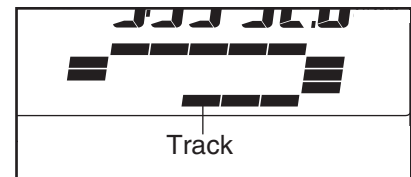

The left side of the display will show the incline level of the treadmill, the elapsed time, and the distance you have walked or run. Note:

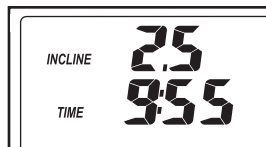

When a program is selected (except for heart rate program 2), the display will show the time remaining in the program instead of the elapsed time.

The right side of the display will show the speed of the walking belt, the approximate number of calories you have burned, and your pace (in minutes per mile). The right side of the display will also show your heart rate when you use the handgrip pulse sensor or the optional chest pulse sensor.



Note: The console can display speed and distance in either miles or kilometers. To determine which unit of measurement is selected, hold down the Stop button while inserting the key into the console. An “E” for English miles or an “M” for metric kilometers will appear in the right side of the display. Press the Speed increase button to change the unit of measurement. When the desired unit of measurement is selected, remove the key. **Note: For simplicity, all instructions in this section refer to miles.**

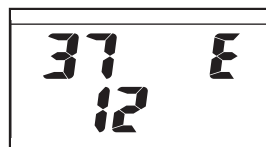

To reset the display, press the Stop button, remove the key, and then reinsert the key.

6 Measure your heart rate if desired.

If there are thin sheets of clear plastic on the metal contacts on the handgrip pulse sen-

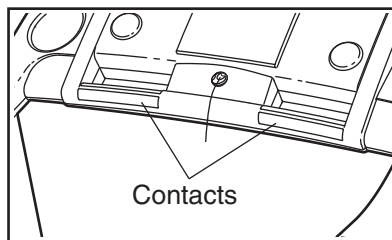

sor, remove the plastic. Before using the handgrip pulse sensor, make sure that your hands are clean. Note: If you use the handgrip pulse sensor and the optional chest pulse sensor at the same time, the console will not display your heart rate accurately.

To measure your heart rate, **stand on the foot rails** and hold the metal contacts on the handrail—**avoid moving your hands**. When your pulse is detected, the heart symbol in the right side of the display will begin to flash, one or two dashes will appear, and then your heart rate will be shown. **For the most accurate heart rate reading, continue to hold the contacts for about 15 seconds.**

7 Turn on the fan if desired.

To turn on the fan, press the fan button (the fan button is located below the Program Select button). To turn on the fan at high speed, press the button a second time. To turn off the fan, press the button a third time. Note: If the fan is left on when the walking belt is stopped, the fan will automatically turn off after a few minutes.

8 When you are finished exercising, remove the key.

Step onto the foot rails, press the Stop button, and **adjust the incline of the treadmill to the lowest setting. The incline must be at the lowest setting when the treadmill is folded to the storage position or the treadmill will be damaged.** Next, remove the key from the console and put it in a secure place. **Note: If the display remains lit after the key is removed, the console is in the “demo” mode. See page 16 and turn off the demo mode.**

When you are finished using the treadmill, switch the reset/off circuit breaker to the “off” position and unplug the power cord.

HOW TO USE A PRESET PROGRAM

1 Insert the key into the console.

See HOW TO TURN ON THE POWER on page 11.

2 Select a preset program.

To select one of the four preset programs, press the Program Select button repeatedly until "P3," "P4," "P5," or "P6" appears in the display. A few seconds after a preset program is selected, the maximum speed setting of the program and the maximum incline setting of the program will flash in the display for a few seconds; in addition, the display will show how long the program will last. The matrix in the lower part of the display will show the first seven speed settings of the program.

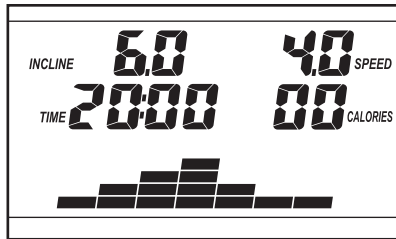

3 Press the Start button or the Speed increase button to start the program.

A moment after the button is pressed, the treadmill will automatically adjust to the first speed and incline settings for the program. Hold the handrails and begin walking.

Each program is divided into 30 one-minute segments. One speed setting and one incline setting are programmed for each segment. Note: The same speed setting and/or incline setting may be programmed for two or more consecutive segments.

The speed setting for the first segment will be shown in the flashing Current Segment column of the matrix in the lower part of the display.

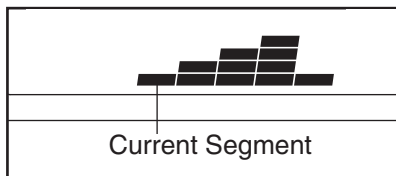

(The incline settings are not shown in the matrix.) The speed settings for the next four segments will be shown in the four columns to the right.

When only three seconds remain in the first segment of the program, both the Current Segment column and the column to the right will flash and a series of tones will sound. If the speed and/or incline of the treadmill is about to change, the speed setting and/or the incline setting will flash in the display to alert you.

When the first segment is completed, *all speed settings will move one column to the left.* The speed setting for the second segment will then be shown in the flashing Current Segment column and the treadmill will automatically adjust to the speed and incline settings for the second segment. Note: If all five of the indicators in the Current Segment column are lit, the speed settings may move downward so that only the highest indicators appear in the matrix.

The program will continue in this way until the speed setting for the last segment is shown in the Current Segment column and the last segment ends. The walking belt will then slow to a stop.

If the speed or incline setting for the current segment is too high or too low, you can manually override the setting by pressing the Speed or Incline buttons. Every few times a Speed button is pressed, an additional indicator will appear or disappear in the Current Segment column; if any of the columns to the right of the Current Segment column have the same number of lit indicators as the Current Segment column, an additional indicator may appear or disappear in those columns as well. **Important: When the current segment of the program ends, the treadmill will automatically adjust to the speed and incline settings for the next segment.**

To stop the program at any time, press the Stop button. To restart the program, press the Start button or the Speed increase button. The walking belt will begin to move at 1 mph. When the next segment of the program begins, the treadmill will automatically adjust to the speed and incline settings for the next segment.

4 Follow your progress with the display.

See step 5 on page 11.

5 Measure your heart rate if desired.

See step 6 on page 12.

6 Turn on the fan if desired.

See step 7 on page 12.

7 When you are finished exercising, remove the key from the console.

See step 8 on page 12.

HOW TO USE A HEART RATE PROGRAM

⚠ CAUTION: If you have heart problems, or if you are over 60 years of age and have been inactive, do not use the heart rate programs. If you are taking medication regularly, consult your physician to find whether the medication will affect your exercise heart rate.

Follow the steps below to use a heart rate program.

1 Put on the optional chest pulse sensor.

You must wear the optional chest pulse sensor (see page 16) to use a heart rate program.

2 Insert the key into the console.

See HOW TO TURN ON THE POWER on page 11.

3 Select a heart rate program.

To select either of the heart rate programs, press the Program Select button repeatedly until “P1” or “P2” appears in the display.

If heart rate program 1 (P1) is selected, the matrix in the lower part of the display will show the first seven

target heart rate settings of the program. Heart rate program 1 will keep your heart rate within a preset range during your workout.

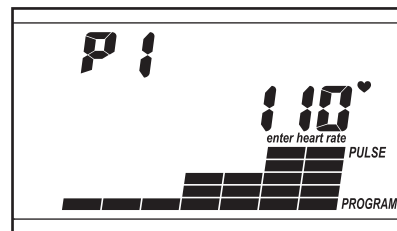

If heart rate program 2 (P2) is selected, a heart symbol will appear in the matrix. Heart rate program 2

will automatically adjust the speed and incline of the treadmill to keep your heart rate near a target heart rate that you select.

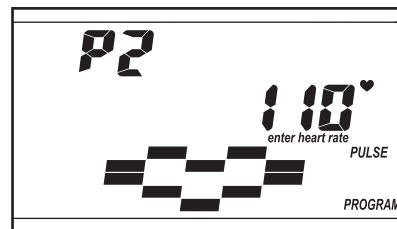

4 Enter a target heart rate setting.

If heart rate program 1 is selected, the maximum target heart rate setting of the program will appear in the display. If desired, press the Heart Rate increase and decrease buttons to change the maximum target heart rate setting (see EXERCISE INTENSITY on page 21). Note: If the maximum target heart rate setting is changed, the intensity level of the entire program will change.

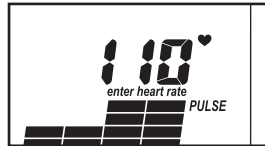

If heart rate program 2 is selected, the target heart rate setting for the program will appear in the display. If desired, press the Heart Rate increase and decrease buttons to change the target heart rate setting (see EXERCISE INTENSITY on page 21). Note: The same target heart rate setting will be programmed for the entire program.

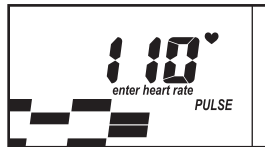

5 Press the Start button or the Speed increase button to start the program.

A moment after the button is pressed, the treadmill will automatically adjust to the first speed and incline settings of the program. Hold the handrails and begin walking.

Heart rate program 1 is divided into 20 one-minute segments. One target heart rate setting is programmed for each segment. (Note: The same target heart rate setting may be programmed for two or more consecutive segments.) Heart rate program 2 is divided into 40 one-minute segments. The same target heart rate setting is programmed for all segments. Note: For a shorter workout, simply stop the program before it ends.

If heart rate program 1 is selected, the target heart rate setting for the first segment will

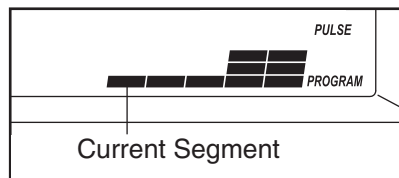

be shown in the flashing Current Segment column of the matrix. The target heart rate settings for the next four segments will be shown in the columns to the right. When only three seconds remain in the first segment, both the Current Segment column and the column to the right will flash and a

series of tones will sound. If a different target heart rate is programmed for the next segment, the speed setting and the incline setting will flash in the display to alert you. When the first segment ends, all target heart rate settings will move one column to the left. The target heart rate setting for the second segment will then be shown in the flashing Current Segment column.

During both heart rate programs, the console will regularly compare your heart rate to the current target heart rate setting. If your heart rate is too far below or above the target heart rate setting, the speed of the walking belt will automatically increase or decrease to bring your heart rate closer to the target heart rate setting. If the speed of the walking belt reaches 7.5 mph and your heart rate is still too far below the target heart rate setting, the incline of the treadmill will also increase.

If the speed or incline setting is too high or too low at any time during the program, you can adjust the setting with the Speed or Incline buttons. However, each time the console compares your heart rate to the target heart rate setting, the speed and/or incline of the treadmill may automatically change to bring your heart rate closer to the target heart rate.

If your pulse is not detected during the program, the letters "PLS" will flash in the display and the speed and/or incline of the treadmill may automatically decrease. If this occurs, see the instructions included with the optional chest pulse sensor.

To stop the program at any time, press the Stop button. To restart the program, press the Start button or the Speed increase button. The walking belt will begin to move at 1 mph. When the console compares your heart rate to the target heart rate setting, the speed and/or incline of the treadmill may automatically change to bring your heart rate closer to the target heart rate setting.

6 Follow your progress with the display.

See step 5 on page 11.

7 Turn on the fan if desired.

See step 7 on page 12.

8 When you are finished exercising, remove the key from the console.

See step 8 on page 12.

THE INFORMATION MODE/DEMO MODE

The console features an information mode that keeps track of the total number of hours that the treadmill has been operated and the total number of miles that the walking belt has moved. The information mode also allows you to select miles or kilometers as the unit of measurement and to turn on and turn off the demo mode.

To select the information mode, hold down the Stop button while inserting the key into the console. When the information mode is selected, the following information will be shown in the display:

The center of the display will show the total number of miles (or kilometers) that the walking belt has moved and the total number of hours that the treadmill has been used. An "E" for English miles or an "M" for metric kilometers will appear in the right side of the display. Press the Speed increase button to change the unit of measurement.

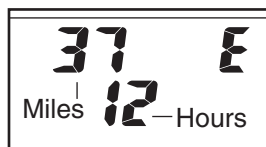

IMPORTANT: If a "d" appears in the right side of the display, the console is in the "demo" mode. This mode is intended to be used only when a treadmill is displayed in a store. When the console is in the demo

mode, the power cord can be plugged in, the key can be removed from the console, and the indicators in the display will automatically appear in a preset sequence, although the buttons on the console will not operate. **If a "d" appears when the information mode is selected, press the Speed decrease button so "d" disappears.**

To exit the information mode, remove the key from the console.

THE OPTIONAL CHEST PULSE SENSOR

An optional chest pulse sensor adds even more features to the console. The chest pulse sensor offers hands-free operation, and enables you to use the console's two heart rate programs. **To purchase the optional chest pulse sensor, call the toll-free telephone number on the front cover of this manual.**

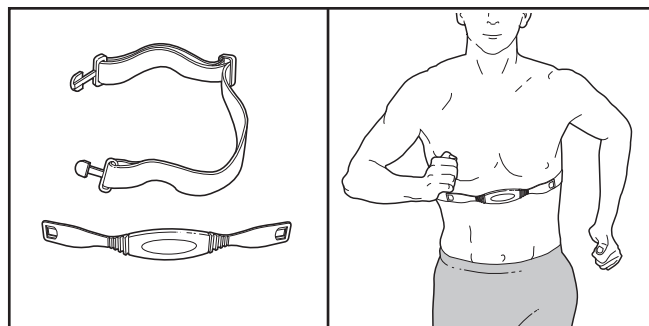

HOW TO FOLD AND MOVE THE TREADMILL

HOW TO FOLD THE TREADMILL FOR STORAGE

Before folding the treadmill, adjust the incline to the lowest position. If this is not done, the treadmill may be permanently damaged. Next, unplug the power cord. **CAUTION: You must be able to safely lift 45 pounds (20 kg) to raise, lower, or move the treadmill.**

1. Hold the treadmill with your hands in the locations shown by the arrow at the right. **To decrease the possibility of injury, bend your legs and keep your back straight. As you raise the treadmill, make sure to lift with your legs rather than your back.** Raise the treadmill about halfway to the vertical position.

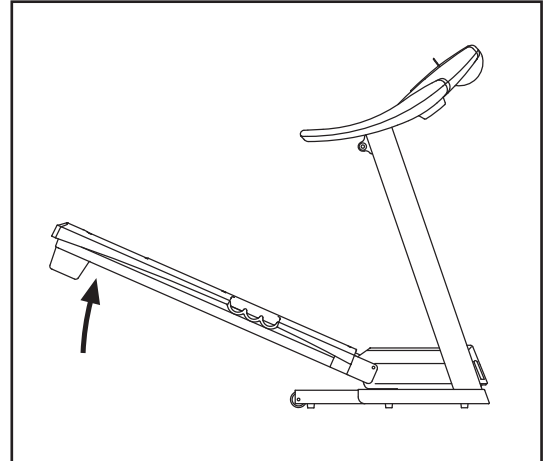

2. Move your right hand to the position shown and hold the treadmill firmly. Using your left hand, pull the latch knob to the left and hold it. Raise the treadmill until the catch is aligned with the latch pin. Slowly release the latch knob. **Make sure that the latch pin is fully inserted into the catch.**

To protect the floor or carpet from damage, place a mat under the treadmill. Keep the treadmill out of direct sunlight. Do not leave the treadmill in the storage position in temperatures above 85° Fahrenheit.

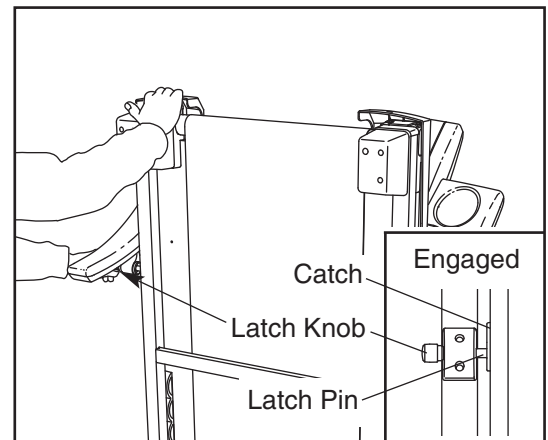

HOW TO MOVE THE TREADMILL

Before moving the treadmill, convert the treadmill to the storage position as described above. **Make sure that the latch pin is fully inserted into the catch.**

1. Hold the upper ends of the handrails. Place one foot against one of the wheels.
2. Tilt the treadmill back until it rolls freely on the front wheels. Carefully move the treadmill to the desired location. **To reduce the risk of injury, use extreme caution while moving the treadmill. Do not move the treadmill over an uneven surface.**
3. Place one foot against one of the wheels, and carefully lower the treadmill until it is resting in the storage position.

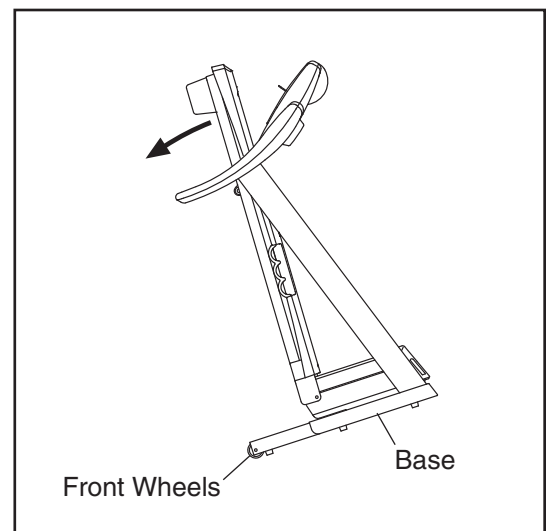

HOW TO LOWER THE TREADMILL FOR USE

1. Hold the upper end of the treadmill with your right hand. Pull the latch knob to the left and hold it. Pivot the treadmill down until the catch is past the latch pin.

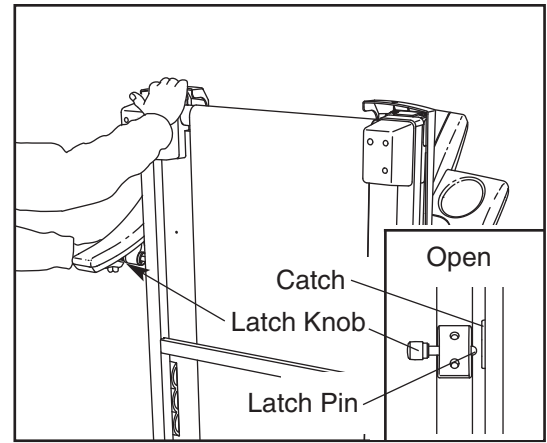

2. Hold the treadmill firmly with both hands, and lower the treadmill to the floor. **Do not drop the treadmill frame to the floor. To decrease the possibility of injury, bend your legs and keep your back straight.**

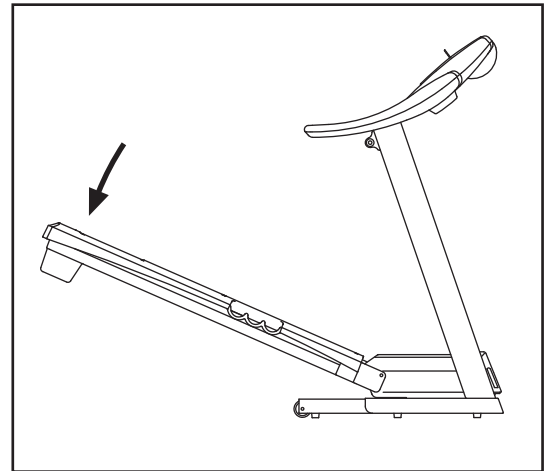

TROUBLESHOOTING

Most treadmill problems can be solved by following the steps below. Find the symptom that applies, and follow the steps listed. If further assistance is needed, please call the toll-free telephone number on the front cover of this manual.

PROBLEM: The power does not turn on

SOLUTION: a. Make sure that the power cord is plugged into a surge suppressor, and that the surge suppressor is plugged into a properly grounded outlet (see page 9). Use only a single-outlet surge suppressor that meets all of the specifications described on page 9. Important: The treadmill is not compatible with GFCI-equipped outlets.

b. After the power cord has been plugged in, make sure that the key is fully inserted into the console.

c. Check the reset/off circuit breaker located on the treadmill frame near the power cord. If the switch protrudes as shown, the circuit breaker has tripped. To reset the circuit breaker, wait for five minutes, and then press the switch back in.

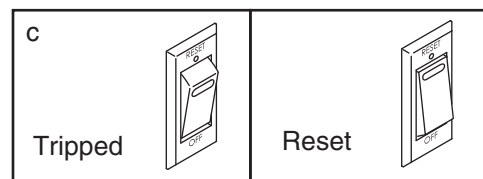

PROBLEM: The power turns off during use

SOLUTION: a. Check the reset/off circuit breaker (see the drawing above). If the circuit breaker has tripped, wait for five minutes and then press the switch back in.

b. Make sure that the power cord is plugged in. If the power cord is plugged in, unplug it, wait for five minutes, and then plug it back in.

c. Remove the key from the console. Reinsert the key into the console.

d. If the treadmill still will not run, see the front cover of this manual.

PROBLEM: The incline of the treadmill does not change correctly

SOLUTION: a. With the key in the console, press one of the Incline buttons. **While the incline is changing, remove the key.** After a few seconds, re-insert the key. The treadmill will automatically rise to the maximum incline level and then return to the minimum level. This will recalibrate the incline system.

PROBLEM: The display of the console does not function properly

SOLUTION: a. Remove the key from the console and **UNPLUG THE POWER CORD.** With the help of a second person, carefully tip the Uprights (84) down as shown. Next, remove the three Screws (3) and the three Hood Screws (7). Note: A phillips screwdriver with a shaft at least 5" long is required.

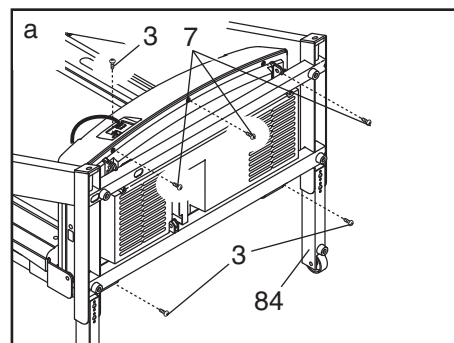

With the help of a second person, carefully raise the Uprights (84) to the position shown. Carefully pivot the Hood (41) off.

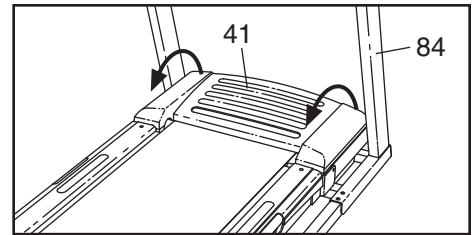

Locate the Reed Switch (63) and the Magnet (46) on the left side of the Pulley (47). Turn the Pulley until the Magnet is aligned with the Reed Switch. **Make sure that the gap between the Magnet and the Reed Switch is about 1/8"**. If necessary, loosen the Screw (3), move the Reed Switch slightly, and then retighten the Screw. Reattach the Hood, and run the treadmill for a few minutes to check for a correct speed reading.

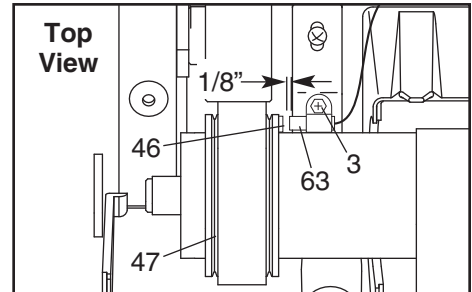

PROBLEM: The walking belt slows when walked on

SOLUTION: a. Use only a single-outlet surge suppressor that meets all of the specifications described on page 9.

b. If the walking belt is overtightened, treadmill performance may decrease and the walking belt may become damaged. Remove the key and **UNPLUG THE POWER CORD**. Using the allen wrench, turn both rear roller adjustment bolts counterclockwise, 1/4 of a turn. When the walking belt is properly tightened, you should be able to lift each side of the walking belt 2 to 3 inches off the walking platform. Be careful to keep the walking belt centered. Plug in the power cord, insert the key, and run the treadmill for a few minutes. Repeat until the walking belt is properly tightened.

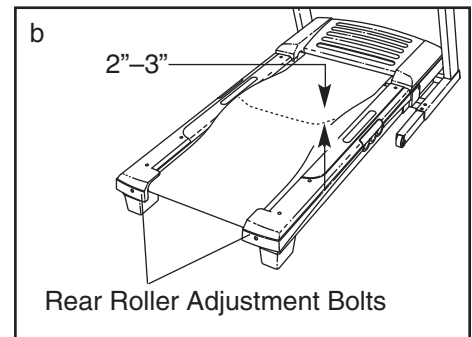

c. If the walking belt still slows when walked on, see the front cover of this manual.

PROBLEM: The walking belt is off-center or slips when walked on

SOLUTION: a. **If the walking belt is off-center**, first remove the key and **UNPLUG THE POWER CORD**. **If the walking belt has shifted to the left**, use the allen wrench to turn the left rear roller bolt clockwise 1/2 of a turn; **if the walking belt has shifted to the right**, turn the left bolt counterclockwise 1/2 of a turn. Be careful not to overtighten the walking belt. Plug in the power cord, insert the key, and run the treadmill for a few minutes. Repeat until the walking belt is centered.

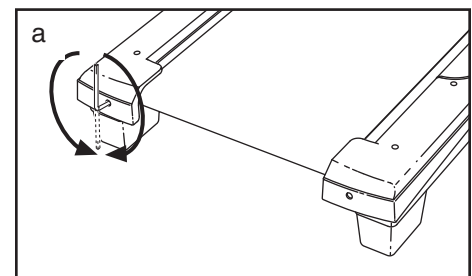

b. **If the walking belt slips when walked on**, first remove the key and **UNPLUG THE POWER CORD**. Using the allen wrench, turn both rear roller bolts clockwise, 1/4 of a turn. When the walking belt is correctly tightened, you should be able to lift each side of the walking belt 2 to 3 inches off the walking platform. Be careful to keep the walking belt centered. Plug in the power cord, insert the key, and carefully walk on the treadmill for a few minutes. Repeat until the walking belt is properly tightened.

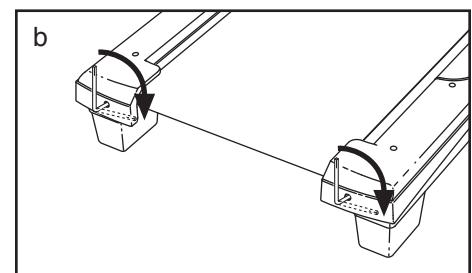

CONDITIONING GUIDELINES

⚠️ WARNING: Before beginning this or any exercise program, consult your physician. This is especially important for individuals over the age of 35 or individuals with pre-existing health problems.

The pulse sensor is not a medical device. Various factors, including your movement, may affect the accuracy of heart rate readings. The sensor is intended only as an exercise aid in determining heart rate trends in general.

The following guidelines will help you to plan your exercise program. For more detailed exercise information, obtain a reputable book or consult your physician.

EXERCISE INTENSITY

Whether your goal is to burn fat or to strengthen your cardiovascular system, the key to achieving the desired results is to exercise with the proper intensity. The proper intensity level can be found by using your heart rate as a guide. The chart below shows recommended heart rates for fat burning and aerobic exercise.

AEROBIC	165	155	145	140	130	125	115
MAX FAT BURN	145	138	130	125	118	110	103
FAT BURN	125	120	115	110	105	95	90
Age	20	30	40	50	60	70	80

To find the proper heart rate for you, first find your age near the bottom of the chart (ages are rounded off to the nearest ten years). Next, find the three numbers above your age. The three numbers define your “training zone.” The lower two numbers are recommended heart rates for fat burning; the higher number is the recommended heart rate for aerobic exercise.

To measure your heart rate during exercise, use the pulse sensor.

Fat Burning

To burn fat effectively, you must exercise at a relatively low intensity level for a sustained period of time. During the first few minutes of exercise, your body uses easily accessible *carbohydrate calories* for en-

ergy. Only after the first few minutes does your body begin to use stored *fat calories* for energy. If your goal is to burn fat, adjust the speed and incline of the treadmill until your heart rate is near the lowest number in your training zone.

For maximum fat burning, adjust the speed and incline of the treadmill until your heart rate is near the middle number in your training zone.

Aerobic Exercise

If your goal is to strengthen your cardiovascular system, your exercise must be “aerobic.” Aerobic exercise is activity that requires large amounts of oxygen for prolonged periods of time. This increases the demand on the heart to pump blood to the muscles, and on the lungs to oxygenate the blood. For aerobic exercise, adjust the speed and incline of the treadmill until your heart rate is near the highest number in your training zone.

WORKOUT GUIDELINES

Each workout should include the following three parts:

A Warm-up—Start each workout with 5 to 10 minutes of stretching and light exercise. A proper warm-up increases your body temperature, heart rate and circulation in preparation for exercise.

Training Zone Exercise—After warming up, increase the intensity of your exercise until your heart rate is in your training zone for 20 to 60 minutes. (During the first few weeks of your exercise program, do not keep your heart rate in your training zone for longer than 20 minutes.) Breathe regularly and deeply as you exercise—never hold your breath.

A Cool-down—Finish each workout with 5 to 10 minutes of stretching to cool down. This will increase the flexibility of your muscles and will help prevent post-exercise problems.

EXERCISE FREQUENCY

To maintain or improve your condition, complete three workouts each week, with at least one day of rest between workouts. After a few months, you may complete up to five workouts each week if desired. The key to success is to make exercise a regular and enjoyable part of your everyday life.

SUGGESTED STRETCHES

The correct form for several basic stretches is shown at the right. Move slowly as you stretch—never bounce.

1. Toe Touch Stretch

Stand with your knees bent slightly and slowly bend forward from your hips. Allow your back and shoulders to relax as you reach down toward your toes as far as possible. Hold for 15 counts, then relax. Repeat 3 times. Stretches: Hamstrings, back of knees and back.

2. Hamstring Stretch

Sit with one leg extended. Bring the sole of the opposite foot toward you and rest it against the inner thigh of your extended leg. Reach toward your toes as far as possible. Hold for 15 counts, then relax. Repeat 3 times for each leg. Stretches: Hamstrings, lower back and groin.

3. Calf/Achilles Stretch

With one leg in front of the other, reach forward and place your hands against a wall. Keep your back leg straight and your back foot flat on the floor. Bend your front leg, lean forward and move your hips toward the wall. Hold for 15 counts, then relax. Repeat 3 times for each leg. To cause further stretching of the achilles tendons, bend your back leg as well. Stretches: Calves, achilles tendons and ankles.

4. Quadriceps Stretch

With one hand against a wall for balance, reach back and grasp one foot with your other hand. Bring your heel as close to your buttocks as possible. Hold for 15 counts, then relax. Repeat 3 times for each leg. Stretches: Quadriceps and hip muscles.

5. Inner Thigh Stretch

Sit with the soles of your feet together and your knees outward. Pull your feet toward your groin area as far as possible. Hold for 15 counts, then relax. Repeat 3 times. Stretches: Quadriceps and hip muscles.

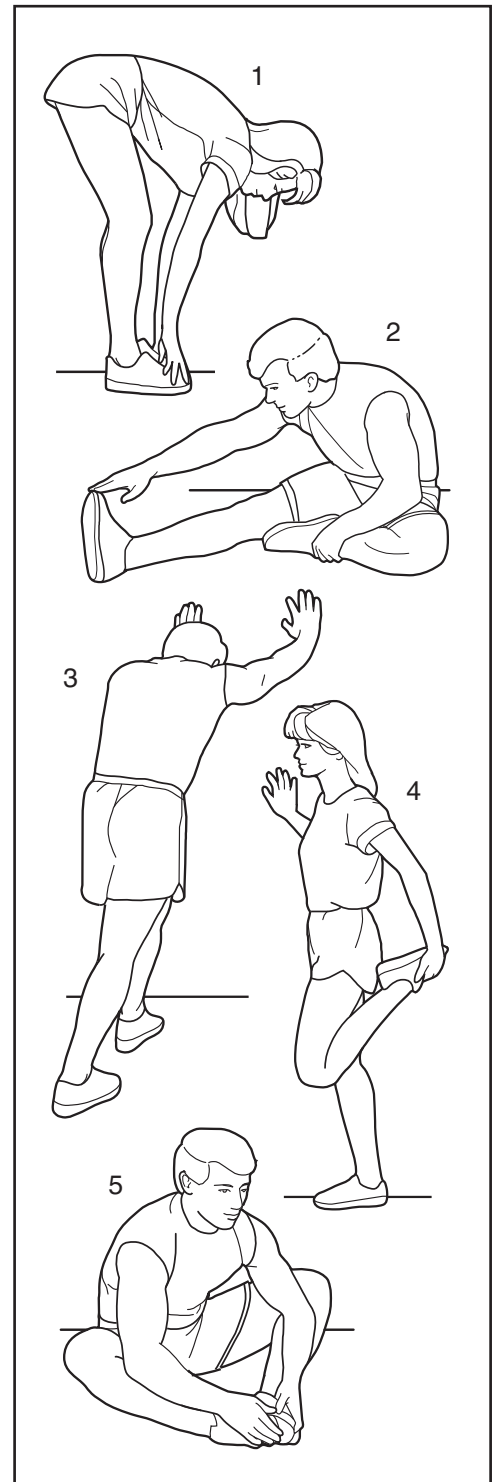

PART LIST—Model No. PFTL51105.1

R0605A

To locate the parts listed below, see the EXPLODED DRAWING attached in the center of this manual.

Key No.	Qty.	Description	Key No.	Qty.	Description
1	2	Foot Rail Cover	50	2	Latch Screw
2	8	3/4" Screw	51	1	Rear Roller
3	41	Screw	52	1	Left Rear Endcap
4	1	Catch	53	2	Rear Roller Bolt
5	10	Foot Rail Screw	54	1	Right Rear Endcap
6	2	Isolator	55	1	Allen Wrench
7	5	Hood Screw	56	1	Incline Stop Bracket
8	8	Star Washer	57	1	Ground Wire
9	2	Platform Bolt (Back)	58	1	Frame
10	2	Platform Bolt (Front)	59	1	Belly Pan
11	4	Belt Guide Screw	60	1	Reed Switch Bracket
12	2	Belt Guide	61	1	Reed Switch Clip
13	1	Left Handrail	62	1	Front Roller Nut
14	1	Right Handrail	63	1	Reed Switch
15	2	Frame Pivot Bolt	64	4	Console Bolt
16	1	Left Foot Rail	65	4	Extension Leg Bolt
17	1	Right Foot Rail	66	5	Star Washer
18	1	Motor Pivot Bolt	67	4	Extension Leg Nut
19	1	Motor Bracket	68	2	Caution Decal
20	1	Console Frame Support	69	1	Warning Decal
21	1	Latch Pin Assembly	70	4	Platform Nut
22	2	Motor Washer	71	1	Cable Tie
23	1	Motor Star Washer	72	1	Cotter Pin
24	2	Motor Bolt	73	1	Latch Housing
25	2	Motor Tension Bolt	74	4	Tie Clamp
26	1	Motor Belt	75	1	Releasable Tie
27	1	Drive Motor	76	1	Access Door
28	2	Frame Washer	77	1	Wire Harness
29	4	U-nut	78	1	Console Wire
30	2	Motor Nut	79	1	Key/Clip
31	2	Lift Frame Bolt	80	2	Front Wheel
32	7	Lock Nut	81	2	Wheel Bolt
33	16	1/2" Screw	82	6	Base Pad
34	1	Console	83	12	1" Tek Screw
35	2	Fan Screw	84	1	Upright
36	1	Power Cord Assembly	85	1	Console Base
37	1	Fan	86	1	Incline Motor Bolt
38	1	Controller	87	1	Hair Pin Cotter Pin
39	1	Electronic Bracket	88	1	Incline Motor
40	1	Filter Wire	89	2	Extension Leg
41	1	Hood	#	1	6" Blue Wire, 2F
42	1	Front Roller Bushing	#	1	10" Red Wire, M/F
43	1	Lift Frame	#	1	12" Green Wire, M/Ring
44	2	Upright Endcap	#	1	8" Black Wire, 2 Ring
45	1	Front Roller Bolt	#	1	User's Manual
46	1	Magnet			
47	1	Front Roller			
48	1	Walking Belt			
49	1	Walking Platform			

"#" indicates a non-illustrated part.

Specifications are subject to change without notice.

EXPLODED DRAWING—Model No. PFTL51105.1

R0605A

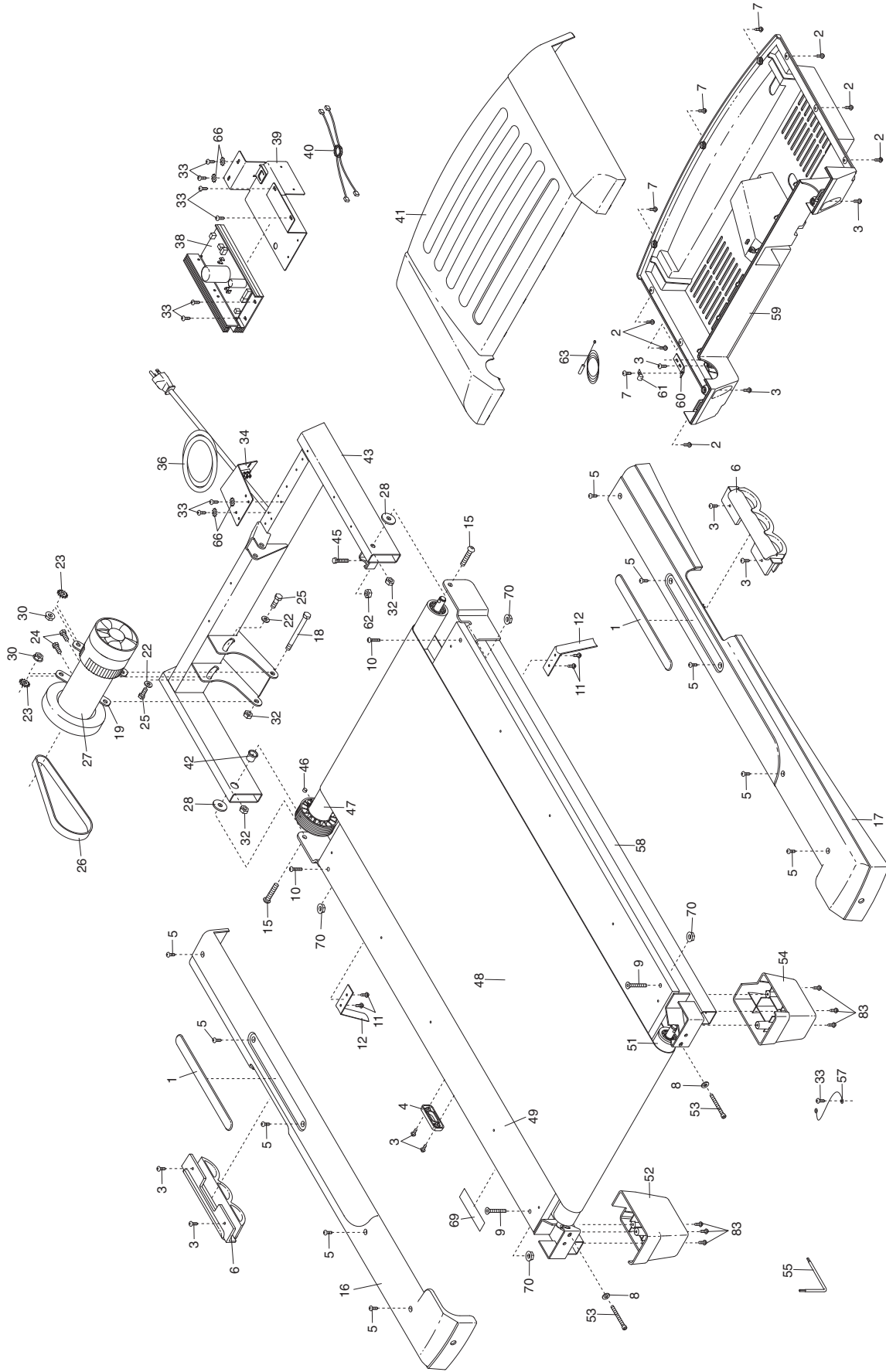

EXPLODED DRAWING—Model No. PFTL51105.1

R0605A

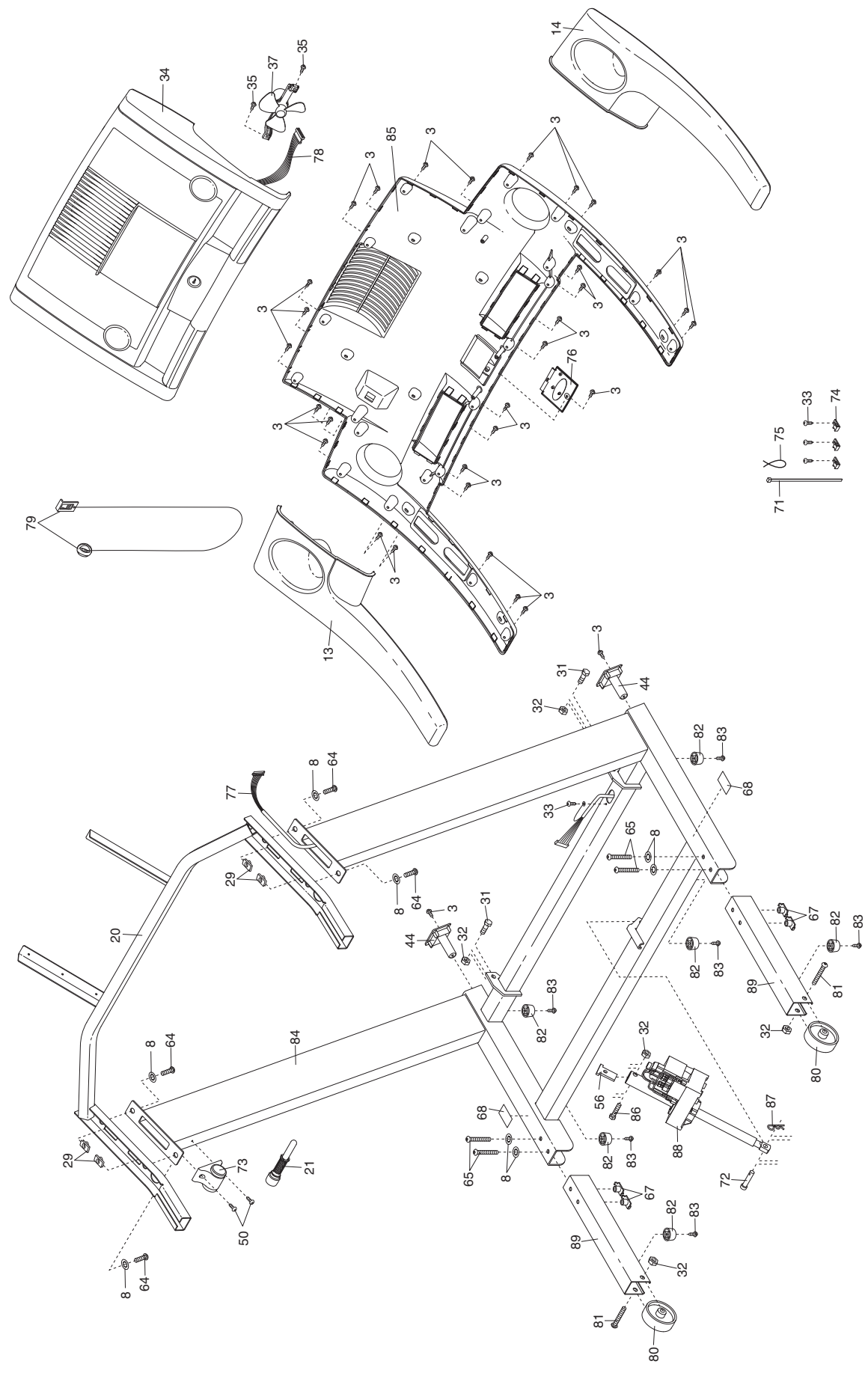

ORDERING REPLACEMENT PARTS

To order replacement parts, see the front cover of this manual. To help us assist you, please be prepared to give the following information:

- the MODEL NUMBER of the product (PFTL51105.1)
- the NAME of the product (PROFORM 6.0 GSX treadmill)
- the SERIAL NUMBER of the product (see the front cover of this manual)
- the KEY NUMBER and DESCRIPTION of the part(s) (see the EXPLODED DRAWING in the center of this manual and the PART LIST on page 23)

LIMITED WARRANTY

ICON Health & Fitness, Inc. (ICON) warrants this product to be free from defects in workmanship and material under normal use and service conditions. The drive motor is warranted for ten (10) years after the date of purchase. Parts and labor are warranted for ninety (90) days after the date of purchase.

This warranty extends only to the original purchaser. ICON's obligation under this warranty is limited to replacing or repairing, at ICON's option, the product through one of its authorized service centers. All repairs for which warranty claims are made must be pre-authorized by ICON. If the product is shipped to a service center, freight charges to and from the service center will be the customer's responsibility. For in-home service, the customer will be responsible for a minimal trip charge. This warranty does not extend to any product or damage to a product caused by or attributable to freight damage, abuse, misuse, improper or abnormal usage or repairs not provided by an ICON authorized service center; products used for commercial or rental purposes; or products used as store display models. No other warranty beyond that specifically set forth above is authorized by ICON.

ICON is not responsible or liable for indirect, special or consequential damages arising out of or in connection with the use or performance of the product or damages with respect to any economic loss, loss of property, loss of revenues or profits, loss of enjoyment or use, costs of removal or installation or other consequential damages of whatsoever nature. Some states do not allow the exclusion or limitation of incidental or consequential damages. Accordingly, the above limitation may not apply to you.

The warranty extended hereunder is in lieu of any and all other warranties and any implied warranties of merchantability or fitness for a particular purpose is limited in its scope and duration to the terms set forth herein. Some states do not allow limitations on how long an implied warranty lasts. Accordingly, the above limitation may not apply to you.

This warranty gives you specific legal rights. You may also have other rights which vary from state to state.

ICON HEALTH & FITNESS, INC., 1500 S. 1000 W., LOGAN, UT 84321-9813