

Model No. PFTL39193

Serial No. _____

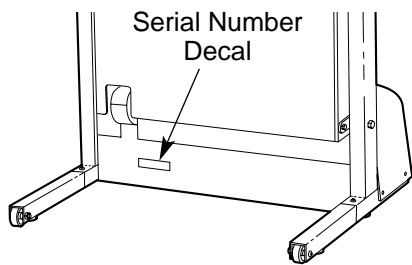

PRO-FORM

385C

POWER INCLINE

USER'S MANUAL

QUESTIONS?

As a manufacturer, we are committed to providing complete customer satisfaction. If you have questions, or if there are missing or damaged parts, we will guarantee complete satisfaction through direct assistance from our factory.

TO AVOID UNNECESSARY DELAYS, PLEASE CALL DIRECT TO OUR TOLL-FREE CUSTOMER HOT LINE. The trained technicians on our Customer Hot Line will provide immediate assistance, free of charge to you.

CUSTOMER HOT LINE:

1-800-999-3756

Mon.-Fri., 6 a.m.-6 p.m. MST

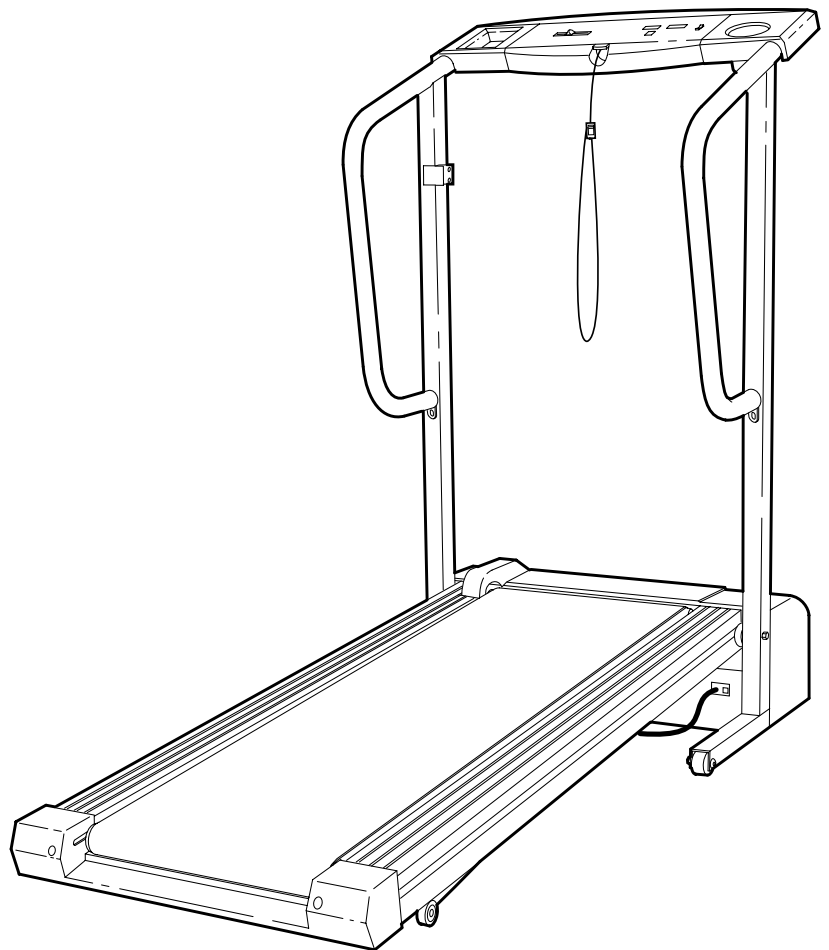

CAUTION

Read all precautions and instructions in this manual before using this equipment. Save this manual for future reference.



Visit our website at

www.proform.com

new products, prizes,
fitness tips, and much more!

TABLE OF CONTENTS

IMPORTANT PRECAUTIONS2
BEFORE YOU BEGIN4
ASSEMBLY5
OPERATION AND ADJUSTMENT7
HOW TO FOLD AND MOVE THE TREADMILL10
TROUBLE-SHOOTING12
CONDITIONING GUIDELINES14
ORDERING REPLACEMENT PARTS	Back Cover
LIMITED WARRANTY	Back Cover

Note: An EXPLODED DRAWING and a PART LIST are attached in the center of this manual. Save the EXPLODED DRAWING and PART LIST for future reference.

IMPORTANT PRECAUTIONS

⚠ WARNING: To reduce the risk of burns, fire, electric shock, or injury to persons, read the following important precautions and information before operating the treadmill.

1. It is the responsibility of the owner to ensure that all users of this treadmill are adequately informed of all warnings and precautions.
2. Use the treadmill only as described.
3. Place the treadmill on a level surface, with 8 feet of clearance behind it. Do not place the treadmill on a surface that blocks any air openings. To protect the floor or carpet from damage, place a mat under the treadmill.
4. Keep the treadmill indoors, away from moisture and dust. Do not put the treadmill in a garage or covered patio, or near water.
5. Do not operate the treadmill where aerosol products are used or where oxygen is being administered.
6. Keep children under the age of 12 and pets away from the treadmill at all times.
7. The treadmill should be used only by persons weighing 250 pounds or less.
8. Never allow more than one person on the treadmill at a time.
9. Wear appropriate exercise clothes when using the treadmill. Do not wear loose clothes that could become caught in the treadmill. Athletic support clothes are recommended for both men and women. Always wear athletic shoes. Never use the treadmill with bare feet, wearing only stockings, or in sandals.
10. When connecting the power cord (see page 7), plug the power cord into a surge protector (not included) and plug the surge protector into a grounded circuit capable of carrying 15 or more amps. No other appliance should be on the same circuit. Do not use an extension cord.
11. Use only a UL-listed surge protector, rated at 15 amps, with a 14-gauge cord of five feet or less in length. Do not use an extension cord.
12. Keep the power cord and the surge protector away from heated surfaces.
13. Never move the walking belt while the power is turned off. Do not operate the treadmill if the power cord or plug is damaged, or if the treadmill is not working properly. (See BEFORE YOU BEGIN on page 4 if the treadmill is not working properly.)

14. Never start the treadmill while you are standing on the walking belt. Always hold the handrails while using the treadmill.

15. The treadmill is capable of high speeds. Adjust the speed in small increments to avoid sudden jumps in speed.

16. Never leave the treadmill unattended while it is running. Always remove the key and unplug the power cord when the treadmill is not in use.

17. Do not attempt to raise, lower, or move the treadmill until it is properly assembled. (See ASSEMBLY on pages 5 and 6, and HOW TO MOVE THE TREADMILL on page 10.) You must be able to safely lift 45 pounds (20 kg) to raise, lower, or move the treadmill.

18. When folding or moving the treadmill, make sure that the storage latch is fully closed.

19. Inspect and tighten all parts of the treadmill every three months.

20. Never drop or insert any object into any opening.

21. **DANGER:** Always unplug the power cord immediately after use, before cleaning the treadmill, and before performing the maintenance and adjustment procedures described in this manual. Never remove the motor hood unless instructed to do so by an authorized service representative. Servicing other than the procedures in this manual should be performed by an authorized service representative only.

22. This treadmill is intended for in-home use only. Do not use this treadmill in any commercial, rental, or institutional setting.

⚠ WARNING: Before beginning this or any exercise program, consult your physician. This is especially important for persons over the age of 35 or persons with pre-existing health problems. Read all instructions before using. ICON assumes no responsibility for personal injury or property damage sustained by or through the use of this product.

SAVE THESE INSTRUCTIONS

The decal shown below has been placed on your treadmill. If the decal is missing, or if it is not legible, please call our Customer Service Department, toll-free, to order a free replacement decal (see ORDERING REPLACEMENT PARTS on the back cover of this manual). Apply the decal in the location shown.

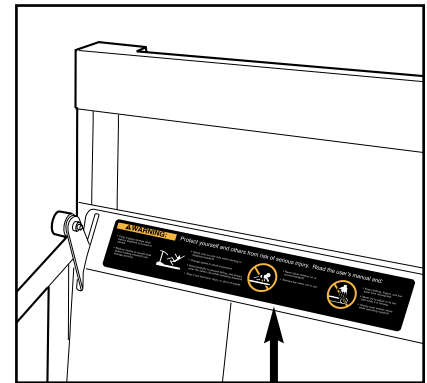

Note: Decal is shown at 38% of actual size.

⚠ WARNING: Protect yourself and others from risk of serious injury. Read the user's manual and:

- Fully engage storage latch before treadmill is moved or stored.
- Reduce incline to lowest level before folding treadmill into storage position.
- Stand only on side rails when starting or stopping treadmill.
- Change speed in small increments.
- Hold handrails to prevent falling, and always wear the safety clip while operating treadmill.
- Stop if you feel faint, dizzy, or short of breath.
- Never allow children on or around treadmill.
- Remove key when not in use.
- Keep clothing, fingers, and hair away from moving belt.
- Never try to adjust or fix the belt while it is moving.
- Always wear athletic shoes while operating treadmill.



BEFORE YOU BEGIN

Thank you for selecting the new PROFORM® 385C treadmill. The 385C treadmill combines advanced technology with innovative design to let you enjoy an excellent form of cardiovascular exercise in the convenience and privacy of your home. And when you're not exercising, the unique 385C can be folded up, requiring less than half the floor space of other treadmills.



For your benefit, read this manual carefully before using the treadmill. If you have additional questions, please call our Customer Service Department toll-free

at 1-800-999-3756, Monday through Friday, 6 a.m. until 6 p.m. Mountain Time (excluding holidays). To help us assist you, please note the product model number and serial number before calling. The model number of the treadmill is PFTL39193. The serial number can be found on a decal attached to the treadmill (see the front cover of this manual for the location).

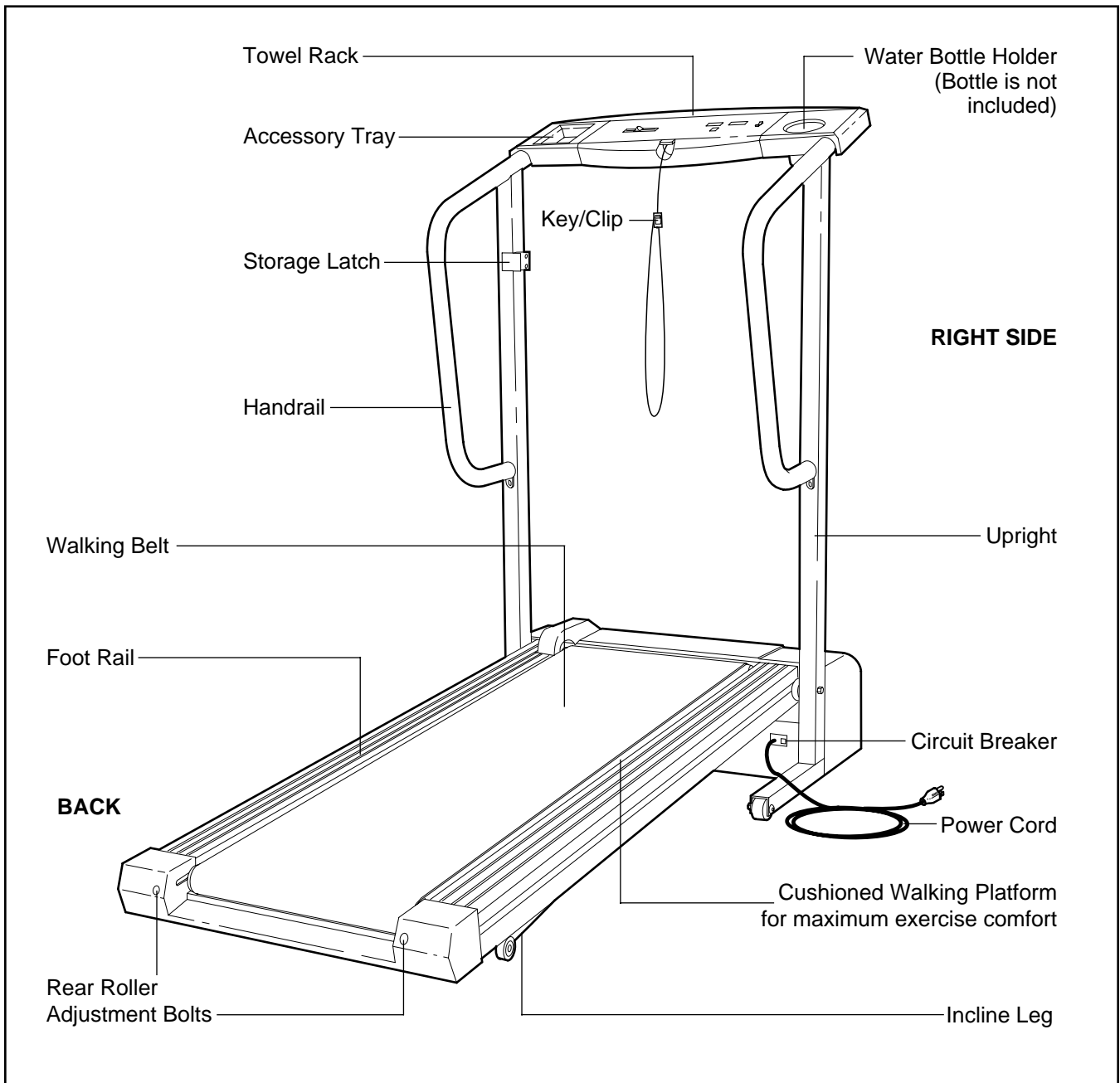
Before reading further, please review the drawing below and familiarize yourself with the labeled parts.

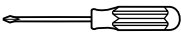

ASSEMBLY

Assembly requires two people. Set the treadmill in a cleared area and remove all packing materials. Do not dispose of the packing materials until assembly is completed. Refer to the drawings below to identify the parts used in assembly. **Assembly requires the following tools: The included allen wrench and your own phillips screwdriver**  **and adjustable wrench**  . 

Note: The underside of the treadmill walking belt is coated with high-performance lubricant. During shipping, a small amount of lubricant may be transferred to the top of the walking belt or the shipping carton. This is a normal condition and does not affect treadmill performance. If there is lubricant on top of the walking belt, simply wipe off the lubricant with a soft cloth and a mild, non-abrasive cleaner.

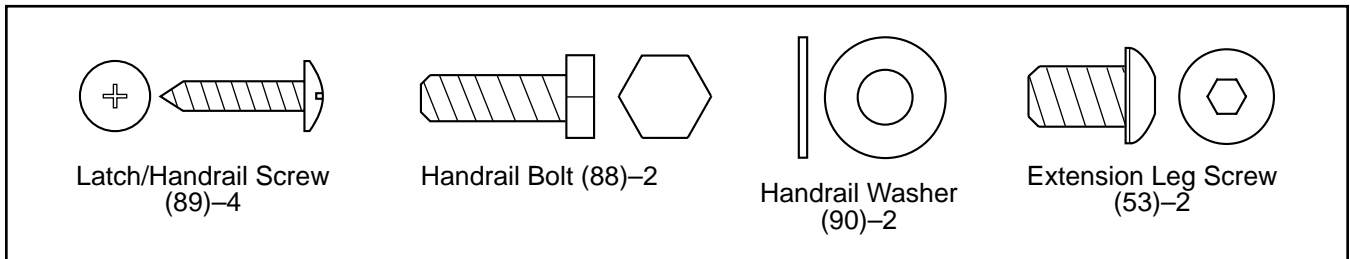

1. With the help of a second person, carefully raise the Uprights (11) until the treadmill is in the position shown.

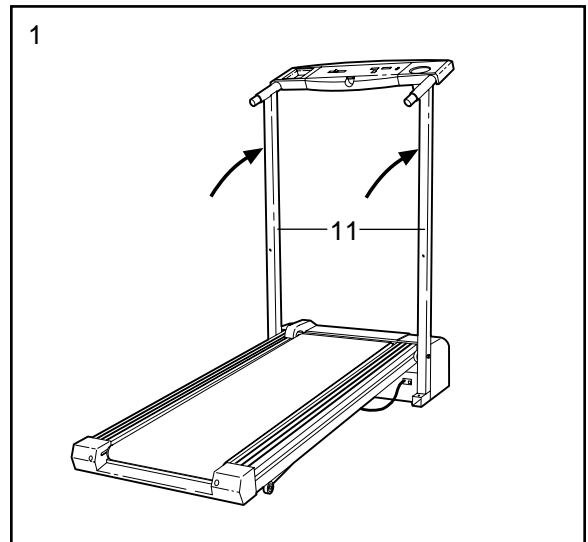

2. Insert one of the Extension Legs (34) into the treadmill as shown. (Note: It may be helpful to tip the Uprights [11] in the direction shown by the arrow as you insert the Extension Leg.) Make sure that the Base Pad (40) is on the indicated side of the Extension Leg. Attach the Extension Leg with an Extension Leg Screw (53). **Be sure to push on the head of the Extension Leg Screw while tightening it.**

Attach the other Extension Leg (34) in the same way.

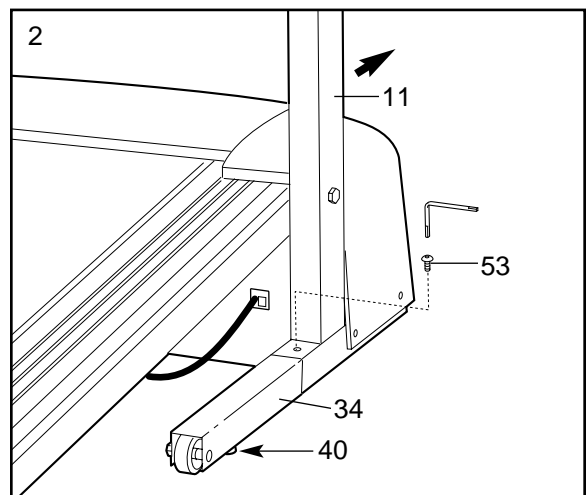

3. Locate the two Rubber Rings (91) that have tapered edges (see the inset drawing). Discard the Rubber Rings without tapered edges.

Slide a Rubber Ring (91) onto the post on each Upright (11). Refer to the inset drawing. **Make sure that each Rubber Ring is turned so that the tapered edge is toward the thickest part of the post.**

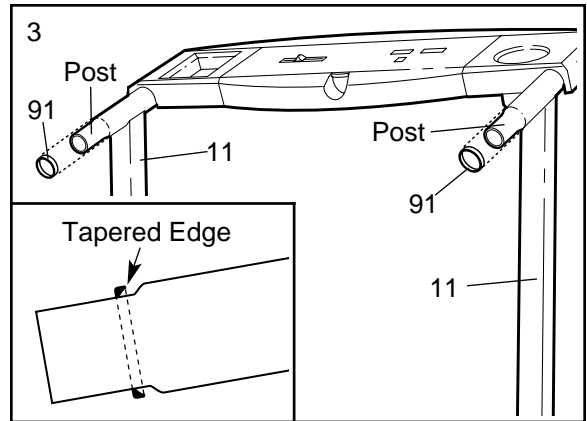

4. Slide the upper end of one of the Handrails (1) onto the post on one of the Uprights (11). Push the Handrail forward as far as possible. Tighten a Handrail Screw (89) into the Handrail. Next, align the lower end of the Handrail with the indicated hole in the Upright. Tighten a Handrail Bolt (88) with a Handrail Washer (90) into the Handrail and the Upright.

Attach the other Handrail (1) in the same way.

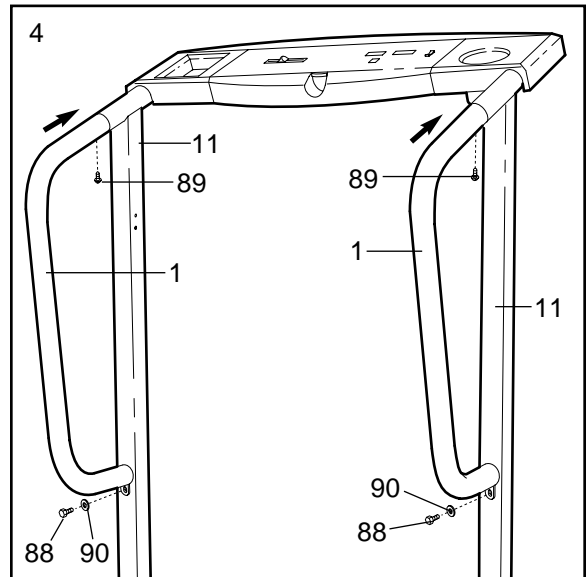

5. Attach the Storage Latch (14) to the left Upright (11) with two Latch Screws (89). **Be careful not to overtighten the Latch Screws.**

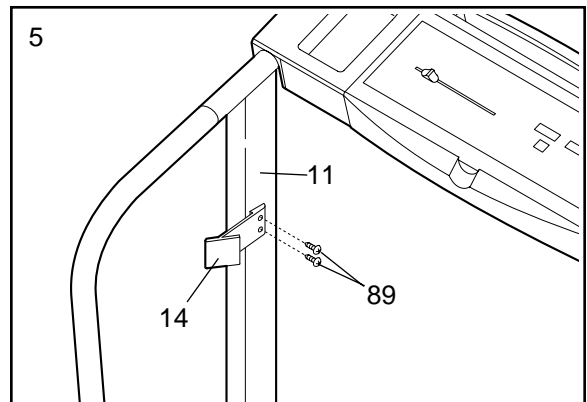

6. **Make sure that all parts are tight before you use the treadmill.** Keep the included allen wrench in a secure place. The allen wrench is used to adjust the walking belt (see page 13). Cover the floor beneath the treadmill to protect the floor or carpet.

OPERATION AND ADJUSTMENT

THE PERFORMANT LUBE™ WALKING BELT

Your treadmill features a walking belt coated with PERFORMANT LUBE™, a high-performance lubricant. **IMPORTANT: Never apply silicone spray or other substances to the walking belt or the walking platform. They will deteriorate the walking belt and cause excessive wear.**

HOW TO PLUG IN THE POWER CORD

⚠ DANGER: Improper connection of the equipment-grounding conductor can result in an increased risk of electric shock. Check with a qualified electrician or serviceman if you are in doubt as to whether the product is properly grounded. Do not modify the plug provided with the product—if it will not fit the outlet, have a proper outlet installed by a qualified electrician.

Your treadmill, like any other type of sophisticated electronic equipment, can be seriously damaged by sudden voltage changes in your home's power. Voltage surges, spikes, and noise interference can result from weather conditions or from other appliances being turned on or off.

To decrease the possibility of your treadmill being damaged, always use a surge protector (not included) with your treadmill.

Surge protectors are sold at most hardware stores and department stores. Use only a UL-listed surge protector, rated at 15 amps, with a 14-gauge cord of five feet or less in length.

This product must be grounded. If it should malfunction or break down, grounding provides a path of least resistance for electric current to reduce the risk of

electric shock. This product is equipped with a cord having an equipment-grounding conductor and a grounding plug. **Plug the power cord into a surge protector, and plug the surge protector into an appropriate outlet that is properly installed and grounded in accordance with all local codes and ordinances. Important: The treadmill is not compatible with GFCI-equipped outlets.**

This product is for use on a nominal 120-volt circuit, and has a grounding plug that looks like the plug illustrated in drawing 1 below. A temporary adapter that looks like the adapter illustrated in drawing 2 may be used to connect the surge protector to a 2-pole receptacle as shown in drawing 2 if a properly grounded outlet is not available.

The temporary adapter should be used only until a properly grounded outlet (drawing 1) can be installed by a qualified electrician.

The green-colored rigid ear, lug, or the like extending from the adapter must be connected to a permanent ground such as a properly grounded outlet box cover. Whenever the adapter is used it must be held in place by a metal screw. **Some 2-pole receptacle outlet box covers are not grounded. Contact a qualified electrician to determine if the outlet box cover is grounded before using an adapter.**

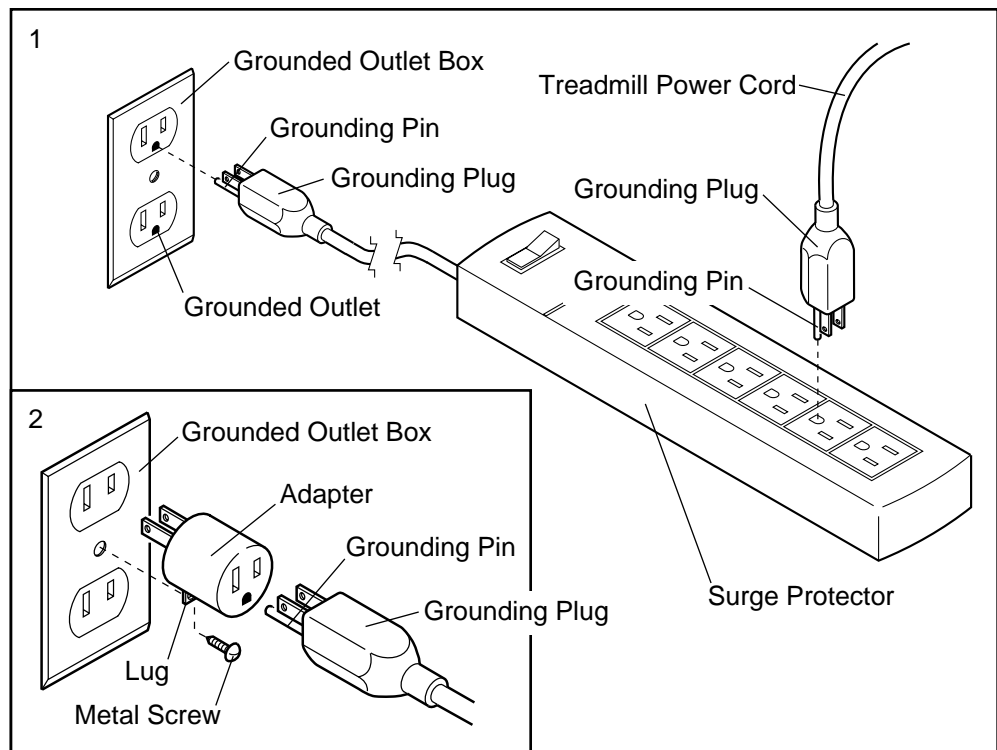
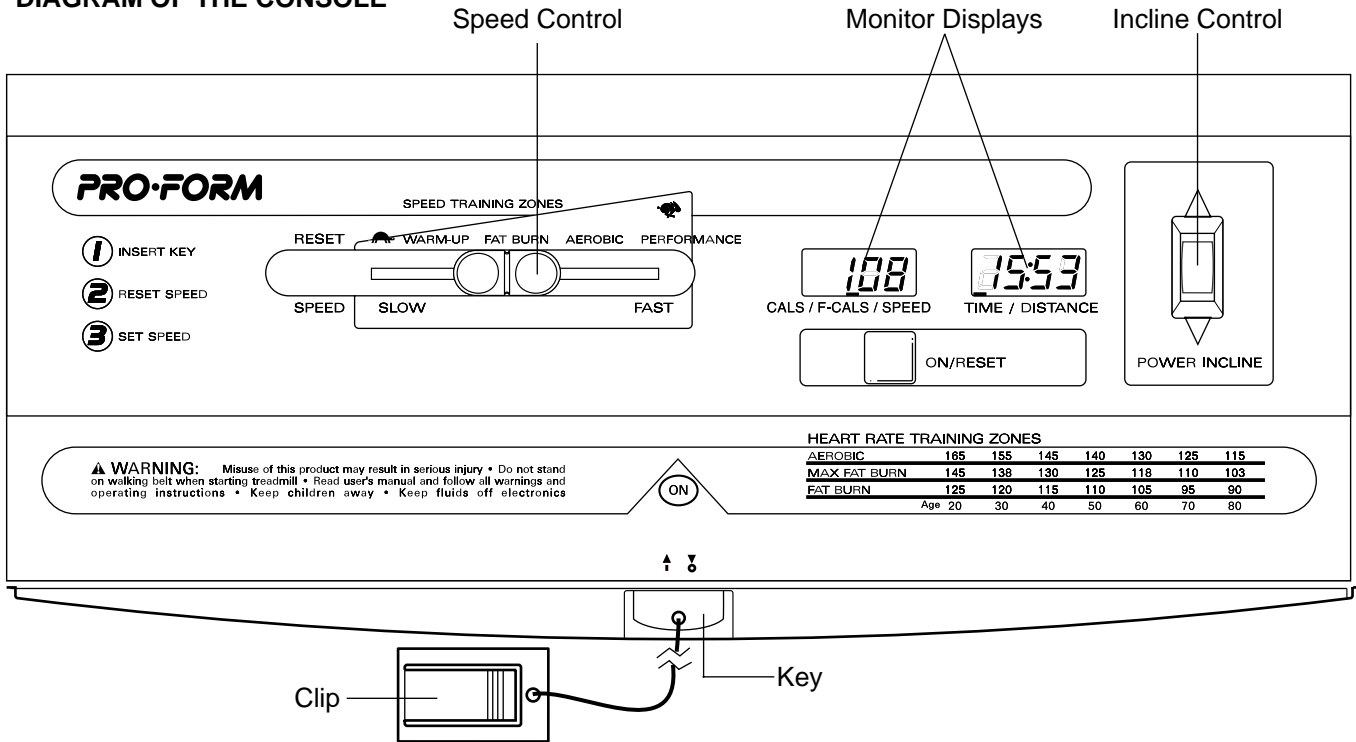

DIAGRAM OF THE CONSOLE



CAUTION: Before operating the console, read the following precautions.

- Do not stand on the walking belt when turning on the power.
- Always wear the clip (see the drawing above) while using the treadmill. When the key is removed from the console, the walking belt will stop.

- Adjust the speed in small increments.
- The training zones marked above the speed control are general guidelines only. See page 14 for more information.
- To reduce the possibility of electric shock, keep the console dry. Avoid spilling liquids on the console. Use only a sealable water bottle.

BATTERY INSTALLATION

The console requires **two "AA" batteries** (not included). Alkaline batteries are recommended. To install batteries, open the battery cover under the console as shown below. Press two batteries into the battery compartment.

Make sure that the negative (-) ends of the batteries are touching the springs.

Close the battery cover.

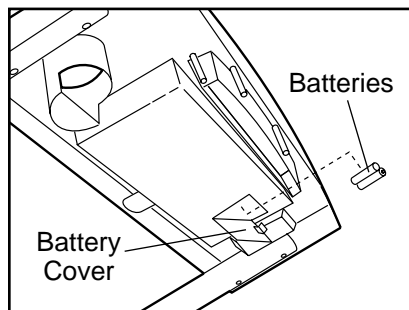

STEP-BY-STEP CONSOLE OPERATION

If there is a thin sheet of clear plastic on the face of the console, remove it.

Before operating the console, make sure that the power cord is properly plugged in. (See **HOW TO PLUG IN THE POWER CORD** on page 7.)

Stand on the foot rails of the treadmill. Find the clip attached to the key and slide the clip onto the waistband of your clothes. Next, insert the key into the console. **Test the clip by carefully taking a few steps backward until the key is pulled from the console. If the key is not pulled from the console, adjust the position of the clip as needed.** Then, remove the key from the console.

Follow the steps below to operate the console.

1 Insert the key into the console.

Inserting the key will not turn on the displays. The displays will turn on when the ON/RESET button is pressed or when the walking belt is started. Note: If you just installed batteries, the displays will already be on.

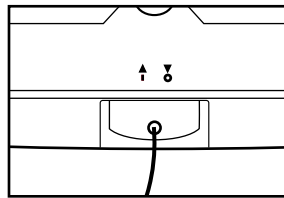

2 Reset the speed control.

Slide the speed control to the RESET position. **Note: Each time the walking belt is stopped, the speed control must be moved to the RESET position before the walking belt can be restarted.**

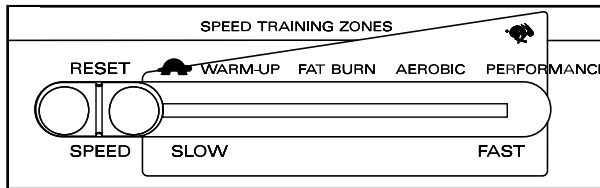

3 Start the walking belt.

After you have moved the speed control to the RESET position, slowly slide it to the right until the walking belt begins to move at slow speed. Carefully step onto the walking belt and begin exercising. Change the speed of the walking belt as desired by sliding the speed control.

To stop the walking belt, step onto the foot rails and slide the speed control to the RESET position.

4 Adjust the incline of the treadmill as desired.

To change the incline of the treadmill, press the top or bottom of the incline control until the desired incline level is reached.

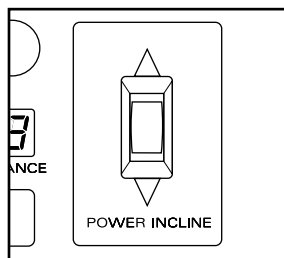

5 Monitor your progress with the two displays.

TIME/DISTANCE display—This display shows the elapsed time and distance that you have walked or run, in miles. Every seven seconds, the display will change from one number to the other. Indicators in the display will indicate which number is currently shown.

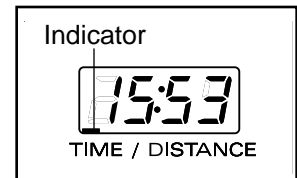

CALS/FAT CALS/SPEED display—This display shows the approximate numbers of calories and fat calories you have burned. (See FAT BURNING on page 14.) In addition, the display shows the speed of the walking belt, in miles per hour. Every seven seconds, the display will change from one number to the other. Indicators in the display will indicate which number is currently shown.

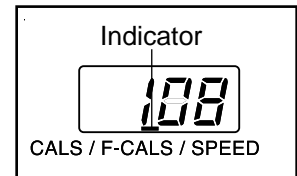

To reset the displays at any time, press the ON/RESET button.

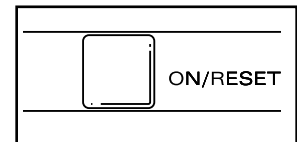

6 When you are finished exercising, stop the walking belt and remove the key.

Step onto the foot rails, slide the speed control to the RESET position, and remove the key from the console. The displays will turn off about five minutes after the key is removed. **Note: Any time that the walking belt is stopped and the ON/RESET button is not pressed for five minutes, the displays will automatically turn off in order to conserve the batteries.**

HOW TO FOLD AND MOVE THE TREADMILL

HOW TO FOLD THE TREADMILL FOR STORAGE

Before folding the treadmill, unplug the power cord. **Caution: You must be able to safely lift 45 pounds (20 kg) in order to raise, lower, or move the treadmill.**

1. Hold the treadmill with your hands in the locations shown at the right. **To decrease the possibility of injury, bend your legs and keep your back straight. As you raise the treadmill, make sure to lift with your legs rather than your back.** Raise the treadmill about halfway to the vertical position.

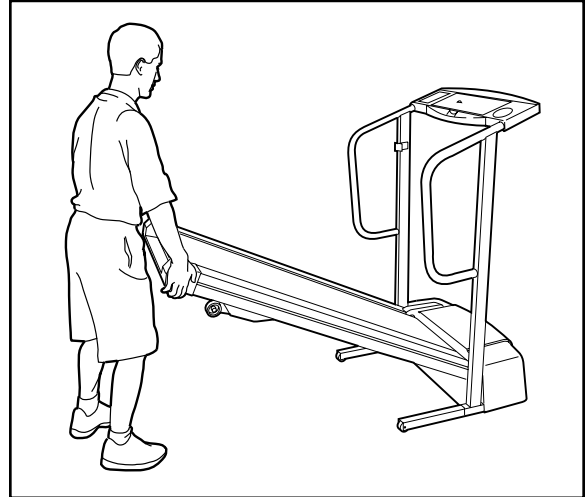

2. Move your right hand to the position shown and hold the treadmill firmly. Raise the treadmill until the storage latch closes over the catch. **Make sure that the storage latch is fully engaged over the catch.**

To protect the floor or carpet from damage, place a mat under the treadmill. Keep the treadmill out of direct sunlight. Do not leave the treadmill in the storage position in temperatures above 85° Fahrenheit.

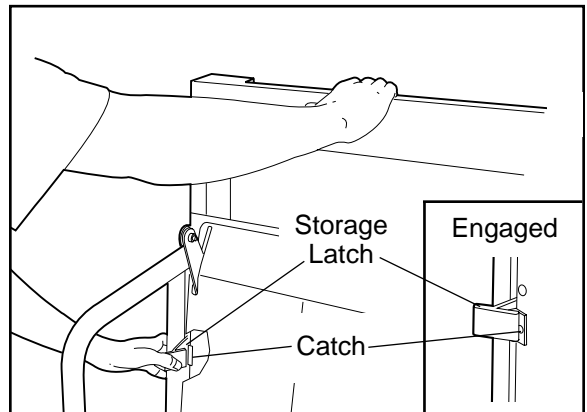

HOW TO MOVE THE TREADMILL

Before moving the treadmill, convert the treadmill to the storage position as described above. **Make sure that the storage latch is closed fully over the catch.**

1. Hold the upper ends of the handrails. Place one foot on the base as shown.
2. Tilt the treadmill back until it rolls freely on the front wheels. Carefully move the treadmill to the desired location. **To reduce the risk of injury, use extreme caution while moving the treadmill. Do not move the treadmill over an uneven surface.**
3. Place one foot on the base, and carefully lower the treadmill until it is resting in the storage position.

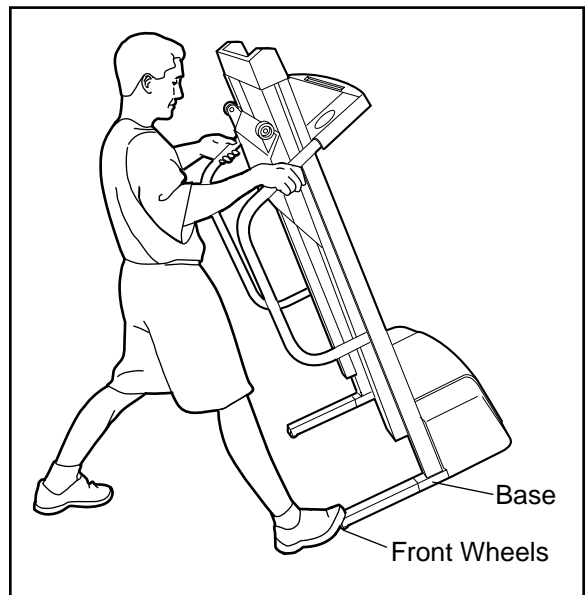

HOW TO LOWER THE TREADMILL FOR USE

1. Hold the upper end of the treadmill with your right hand as shown. Using your left thumb, press the storage latch and hold it. Pivot the treadmill until the frame and foot rail are past the storage latch.

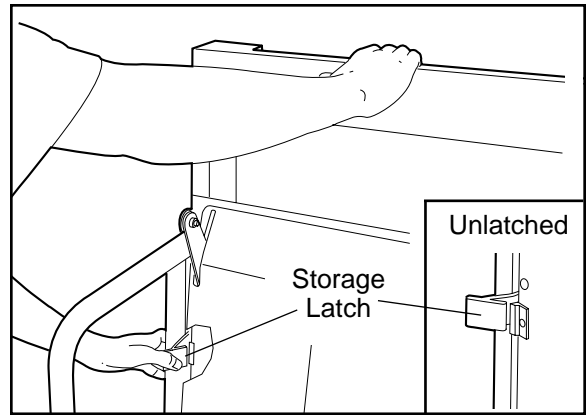

2. Hold the treadmill firmly with both hands, and lower the treadmill to the floor. **To decrease the possibility of injury, bend your legs and keep your back straight.**

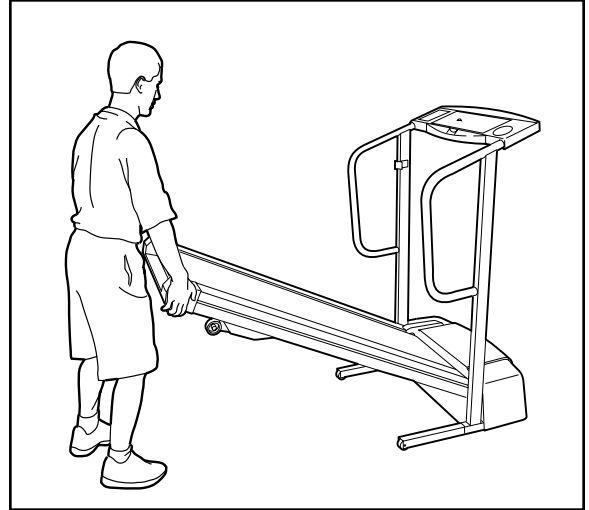

TROUBLE-SHOOTING

Most treadmill problems can be solved by following the steps below. Find the symptom that applies, and follow the steps listed. If further assistance is needed, please call our Customer Service Department toll-free at 1-800-999-3756, Monday through Friday, 6 a.m. until 6 p.m. Mountain Time (excluding holidays).

1. SYMPTOM: THE POWER DOES NOT TURN ON

- Make sure that the power cord is plugged into a surge protector, and that the surge protector is plugged into a properly grounded outlet. (See HOW TO PLUG IN THE POWER CORD on page 7.) Use only a UL-listed surge protector, rated at 15 amps, with a 14-gauge cord of five feet or less in length. Important: The treadmill is not compatible with GFCI-equipped outlets.
- After the power cord has been plugged in, make sure that the key is fully inserted into the console.
- Check the circuit breaker located on the treadmill near the power cord. If the switch protrudes as shown, the circuit breaker has tripped. To reset the circuit breaker, wait for five minutes and then press the switch back in.

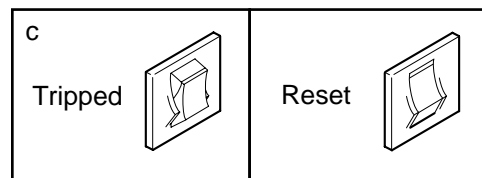

2. SYMPTOM: THE POWER TURNS OFF DURING USE

- Check the circuit breaker located on the treadmill frame near the power cord (see 1. c. above). If the circuit breaker has tripped, wait for five minutes and then press the switch back in.
- Make sure that the power cord is plugged in.
- Remove the key from the console. Reinsert the key fully into the console.
- If the treadmill still will not run, please call our Customer Service Department, toll-free.

3. SYMPTOM: THE DISPLAYS OF THE CONSOLE DO NOT FUNCTION PROPERLY

- Check the batteries in the console. See BATTERY INSTALLATION on page 8. Most problems are the result of drained batteries.
- Remove the key from the console and **UNPLUG THE POWER CORD**. Remove the screws from the hood. Carefully remove the hood. Locate the Reed Switch (44) and the Magnet (45) on the left side of the Pulley (50). Turn the Pulley until the Magnet is aligned with the Reed Switch. **Make sure that the gap between the Magnet and the Reed Switch is about 1/8"**. If necessary, loosen the Screw (33) and move the Reed Switch slightly. Retighten the Screw. Re-attach the hood, and run the treadmill for a few minutes to check for a correct speed reading.

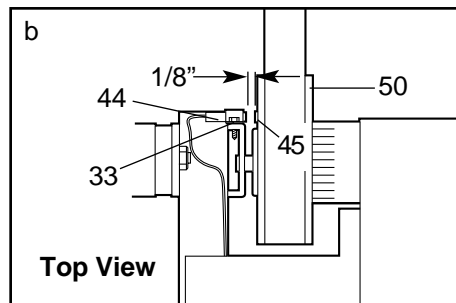

4. SYMPTOM: THE WALKING BELT SLOWS WHEN WALKED ON

- a. Use only a UL-listed surge protector, rated at 15 amps, with a 14-gauge cord of five feet or less in length.
- b. If the walking belt is overtightened, treadmill performance may decrease and the walking belt may be permanently damaged. Remove the key and **UNPLUG THE POWER CORD**. Using the allen wrench, turn both rear roller adjustment bolts counterclockwise, 1/4 of a turn. When the walking belt is properly tightened, you should be able to lift each side of the walking belt 2 to 3 inches off the walking platform. The center of the walking belt should just touch the walking platform. Be careful to keep the walking belt centered. Plug in the power cord, insert the key and run the treadmill for a few minutes. Repeat until the walking belt is properly tightened.

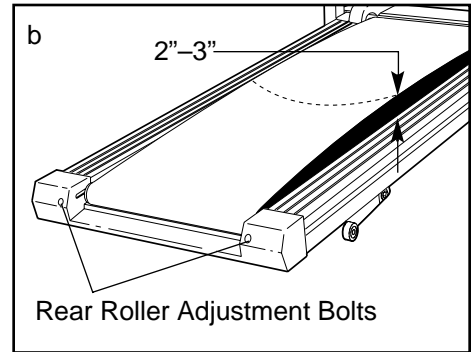

- c. If the walking belt still slows when walked on, please call our Customer Service Department, toll-free.

5. SYMPTOM: THE WALKING BELT IS OFF-CENTER

- a. **If the walking belt has shifted to the left**, first remove the key and **UNPLUG THE POWER CORD**. Using the allen wrench, turn the left rear roller adjustment bolt clockwise, and the right bolt counterclockwise, 1/4 of a turn each. Be careful not to overtighten the walking belt. Plug in the power cord, insert the key and run the treadmill for a few minutes. Repeat until the walking belt is centered.

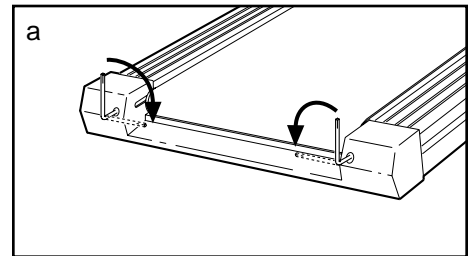

- b. **If the walking belt has shifted to the right**, first remove the key and **UNPLUG THE POWER CORD**. Using the allen wrench, turn the left rear roller adjustment bolt counterclockwise, and the right bolt clockwise, 1/4 of a turn each. Be careful not to overtighten the walking belt. Plug in the power cord, insert the key and run the treadmill for a few minutes. Repeat until the walking belt is centered.

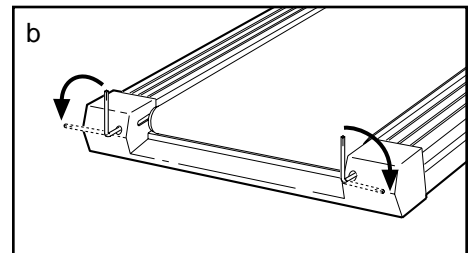

- c. **If the walking belt slips when walked on**, first remove the key and **UNPLUG THE POWER CORD**. Using the allen wrench, turn both rear roller adjustment bolts clockwise, 1/4 of a turn. When the walking belt is correctly tightened, you should be able to lift each side of the walking belt 2 to 3 inches off the walking platform. Be careful to keep the walking belt centered. Plug in the power cord, insert the key and run the treadmill for a few minutes. Repeat until the walking belt is properly tightened.

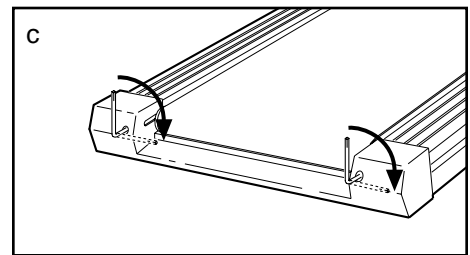

CONDITIONING GUIDELINES

⚠️ WARNING: Before beginning this or any exercise program, consult your physician. This is especially important for individuals over the age of 35 or individuals with pre-existing health problems.

The following guidelines will help you to plan your exercise program. For more detailed exercise information, obtain a reputable book or consult your physician.

EXERCISE INTENSITY

Whether your goal is to burn fat or to strengthen your cardiovascular system, the key to achieving the desired results is to exercise with the proper intensity. The proper intensity level can be found by using your heart rate as a guide. The chart below shows recommended heart rates for fat burning and aerobic exercise.

HEART RATE TRAINING ZONES								
AEROBIC	165	155	145	140	130	125	115	
MAX FAT BURN	145	138	130	125	118	110	103	
FAT BURN	125	120	115	110	105	95	90	
	Age	20	30	40	50	60	70	80

To find the proper heart rate for you, first find your age at the bottom of the chart (ages are rounded off to the nearest ten years). Next, find the three numbers above your age. The three numbers are your “training zone.” The lower two numbers are recommended heart rates for fat burning; the highest number is the recommended heart rate for aerobic exercise.

Fat Burning

To burn fat effectively, you must exercise at a relatively low intensity level for a sustained period of time. During the first few minutes of exercise, your body uses easily accessible carbohydrate calories for energy. Only after the first few minutes does your body begin to use stored fat calories for energy. If your goal is to burn fat, adjust the speed and incline of the treadmill until your heart rate is near the lower two numbers in your training zone. It may also be helpful to set the speed control on the console to FAT BURN to help you maintain the proper intensity level. (See page 9.)

Aerobic Exercise

If your goal is to strengthen your cardiovascular system, your exercise must be “aerobic.” Aerobic exercise is activity that requires large amounts of oxygen for prolonged periods of time. This increases the demand on the heart to pump blood to the muscles, and on the lungs to oxygenate the blood. For aerobic exercise, adjust the speed and incline of the treadmill until your heart rate is near the highest number in your training zone. It may also be helpful to set the speed control on the console to AEROBIC to help you maintain the proper intensity level. (See page 9.)

High Performance Athletic Conditioning

If your goal is high performance athletic conditioning, set the speed control on the console to PERFORMANCE to help you maintain the proper intensity level. (See page 9.) Note: During the first few weeks of your exercise program, keep your heart rate near the low end of your training zone.

HOW TO MEASURE YOUR HEART RATE

To measure your heart rate, stop exercising and place two fingers on your wrist as shown. Take a six-second heartbeat count, and multiply the result by ten to find your heart rate. (A six-second count is used because your heart rate drops quickly when you stop exercising.) If your heart rate is too high or too low, adjust the speed or incline of the treadmill accordingly.

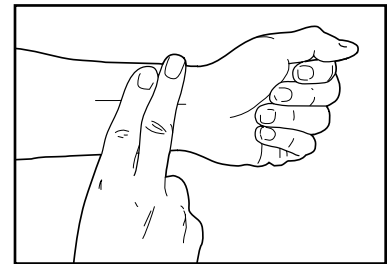

WORKOUT GUIDELINES

A well-rounded workout includes the following three important parts:

A Warm-up

Start each workout with 5 to 10 minutes of stretching and light exercise (see SUGGESTED STRETCHES on page 15). A proper warm-up increases your body temperature, heart rate, and circulation in preparation for exercise.

Training Zone Exercise

After warming up, increase the intensity of your exercise until your heart rate is in your training zone for 20 to 60 minutes. (During the first few weeks of your exercise program, do not keep your heart rate in your training zone for longer than 20 minutes.) Breathe regularly and deeply as you exercise—never hold your breath.

A Cool-down

Finish each workout with 5 to 10 minutes of stretching

to cool down. This will increase the flexibility of your muscles and will help to prevent post-exercise problems.

Exercise Frequency

To maintain or improve your condition, complete three workouts each week, with at least one day of rest between workouts. After a few months, you may complete up to five workouts each week if desired.

The key to success is to make exercise a regular and enjoyable part of your everyday life.

SUGGESTED STRETCHES

The correct form for several basic stretches is shown at the right. Move slowly as you stretch—never bounce.

1. Toe Touch Stretch

Stand with your knees bent slightly and slowly bend forward from your hips. Allow your back and shoulders to relax as you reach down toward your toes as far as possible. Hold for 15 counts, then relax. Repeat 3 times. Stretches: Hamstrings, back of knees, and back.

2. Hamstring Stretch

Sit with one leg extended. Bring the sole of the opposite foot toward you and rest it against the inner thigh of your extended leg. Reach toward your toes as far as possible. Hold for 15 counts, then relax. Repeat 3 times for each leg. Stretches: Hamstrings, lower back, and groin.

3. Calf/Achilles Stretch

With one leg in front of the other, reach forward and place your hands against a wall. Keep your back leg straight and your back foot flat on the floor. Bend your front leg, lean forward and move your hips toward the wall. Hold for 15 counts, then relax. Repeat 3 times for each leg. To cause further stretching of the achilles tendons, bend your back leg as well. Stretches: Calves, achilles tendons, and ankles.

4. Quadriceps Stretch

With one hand against a wall for balance, reach back and grasp one foot with your other hand. Bring your heel as close to your buttocks as possible. Hold for 15 counts, then relax. Repeat 3 times for both legs. Stretches: Quadriceps and hip muscles.

5. Inner Thigh Stretch

Sit with the soles of your feet together and your knees outward. Pull your feet toward your groin area as far as possible. Hold for 15 counts, then relax. Repeat 3 times. Stretches: Quadriceps and hip muscles.

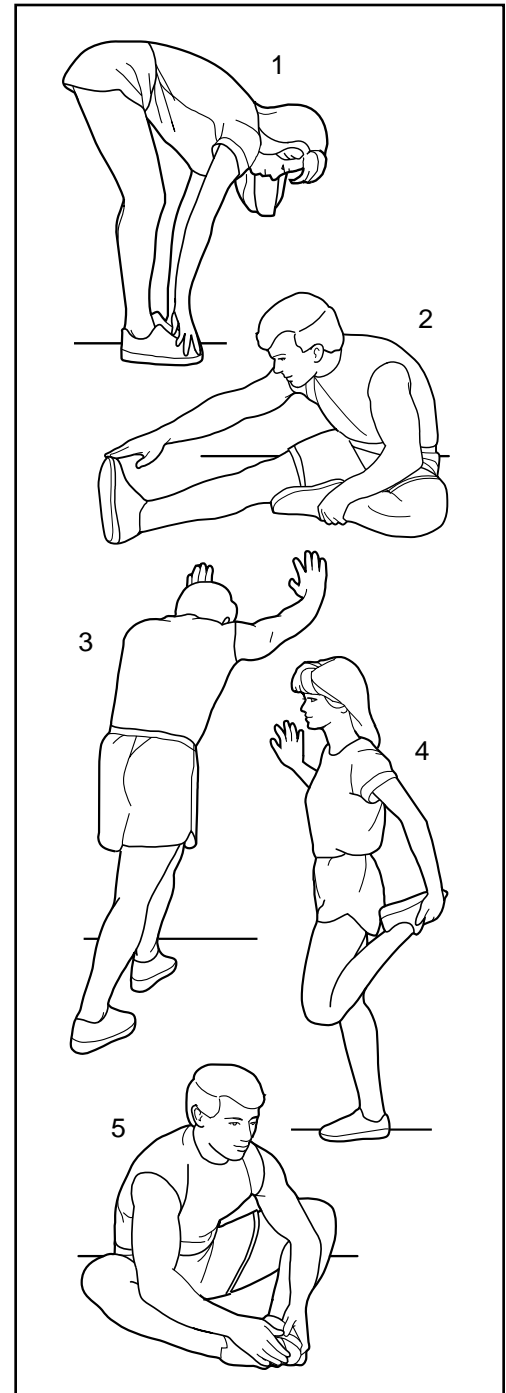

ORDERING REPLACEMENT PARTS

To order replacement parts, call our Customer Service Department toll-free at 1-800-999-3756, Monday through Friday, 6 a.m. until 6 p.m. Mountain Time (excluding holidays). When ordering parts, please be prepared to give the following information:

- The MODEL NUMBER OF THE PRODUCT (PFTL39193)
- The NAME OF THE PRODUCT (PROFORM® 385C treadmill)
- The SERIAL NUMBER OF THE PRODUCT (see the front cover of this manual)
- The KEY NUMBER AND DESCRIPTION OF THE PART(S) (see the EXPLODED DRAWING and PART LIST attached in the center of this manual).

If possible, place the treadmill near your telephone for easy reference when calling.

PROFORM is a registered trademark of ICON Health & Fitness, Inc.

LIMITED WARRANTY

ICON Health & Fitness, Inc. (ICON), warrants this product to be free from defects in workmanship and material, under normal use and service conditions, for a period of ninety (90) days from the date of purchase. This warranty extends only to the original purchaser. ICON's obligation under this warranty is limited to replacing or repairing, at ICON's option, the product at one of its authorized service centers. All products for which warranty claim is made must be received by ICON at one of its authorized service centers with all freight and other transportation charges prepaid, accompanied by sufficient proof of purchase. All returns must be pre-authorized by ICON. This warranty does not extend to any product or damage to a product caused by or attributable to freight damage, abuse, misuse, improper or abnormal usage or repairs not provided by an ICON authorized service center, to products used for commercial or rental purposes, or to products used as store display models. No other warranty beyond that specifically set forth above is authorized by ICON.

ICON is not responsible or liable for indirect, special or consequential damages arising out of or in connection with the use or performance of the product or damages with respect to any economic loss, loss of property, loss of revenues or profits, loss of enjoyment or use, costs of removal, installation or other consequential damages of whatsoever nature. Some states do not allow the exclusion or limitation of incidental or consequential damages. Accordingly, the above limitation may not apply to you.

The warranty extended hereunder is in lieu of any and all other warranties and any implied warranties of merchantability or fitness for a particular purpose is limited in its scope and duration to the terms set forth herein. Some states do not allow limitations on how long an implied warranty lasts. Accordingly, the above limitation may not apply to you.

This warranty gives you specific legal rights. You may also have other rights which vary from state to state.

ICON HEALTH & FITNESS, INC., 1500 S. 1000 W., LOGAN, UT 84321-9813

REMOVE THIS EXPLODED DRAWING AND PART LIST FROM THE MANUAL

Save this EXPLODED DRAWING and PART LIST for future reference.

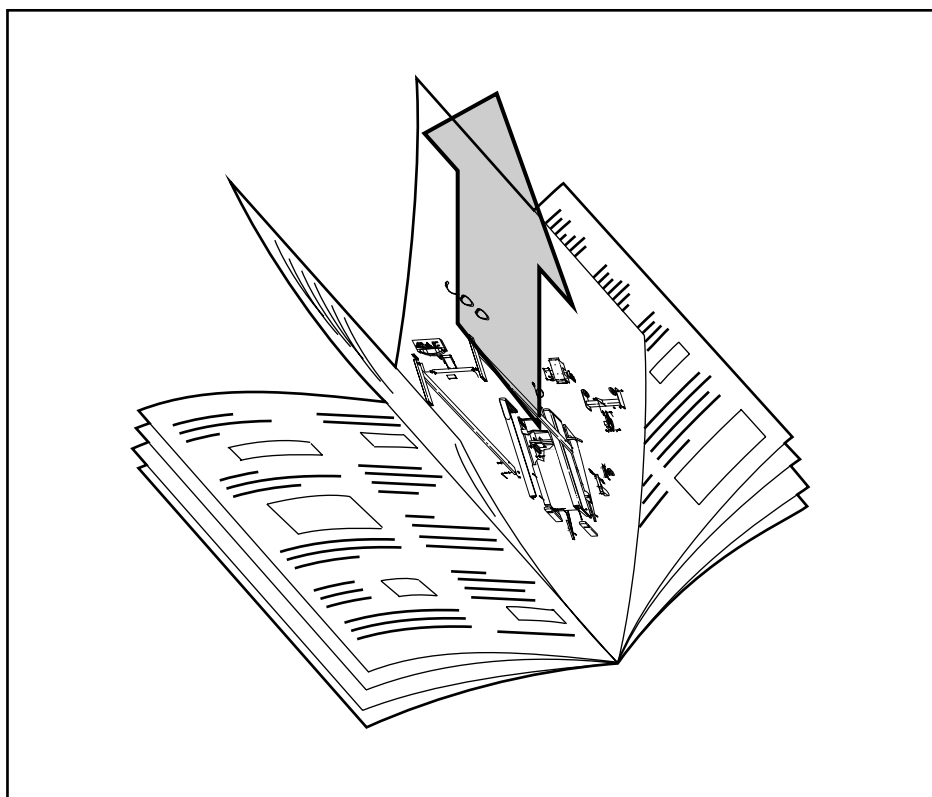

Note: Specifications are subject to change without notice. For information about ordering replacement parts, see the back cover of the User's Manual.

PART LIST—Model No. PFTL39193

R0201A

Key No.	Qty.	Description	Key No.	Qty.	Description
1	2	Handrail	50	1	Front Roller/Pulley
2	1	Key/Clip	51	1	Front Roller Adj. Bolt
3	8	Screw	52	2	Incline Wheel
4	1	Battery Cover	53	4	Extension Leg Screw
5	2	Foot Rail	54	1	Power Cord
6	1	Lift Motor	55	1	Power Cord Grommet
7	1	Frame Guide	56	1	Circuit Breaker
8	1	Speed Potentiometer	57	2	Frame Pivot Washer
9	1	Speed Control Knob	58	2	Frame Pivot Bolt
10*	1	Console Assembly	59	2	Roller Guard
11	1	Upright/Base	60	1	Motor Belly Pan
12	1	Motor Belt	61	1	1" Grommet
13	11	Small Screw	62	2	Rear Platform Screw
14	1	Storage Latch	63	1	Releasable Tie
15	2	4" Cable Tie	64	1	Choke
16	7	8" Cable Tie	65	2	Belt Guide
17	1	Motor Swivel Nut	66	4	Belly Pan Fastener
18	1	Pulley/Flywheel/Fan	67	1	Walking Belt
19	1	Motor	68	1	Walking Platform
20*	1	Motor/Pulley/Flywheel/Fan	69	1	Belly Pan
21	1	Wire Harness	70	4	Electronics Screw
22	8	Hood Screw	71	1	Incline Wire Harness
23	1	Motor Hood	72	1	Wire Tie Holder
24	1	Hood Shield	73	8	Isolator Screw
25	6	Small Screw	74	1	Allen Wrench
26	1	Controller	75	1	Frame
27	1	Motor Swivel Bolt	76	1	Left Front Endcap
28	1	Motor Tension Nut	77	2	Incline Wheel Bolt
29	1	Motor Tension Star Washer	78	1	Right Front Endcap
30	1	Motor Tension Washer	79	2	Incline Wheel Nut
31	5	Motor Tension Bolt/Leg Bolt	80	1	Ground Wire
32	1	Incline Stop Bracket	81	2	Ground Screw
33	9	Belly Pan/Clip/Handrail Screw	82	1	Incline Leg
34	2	Extension Leg	83	2	Rear Roller Adj. Bolt
35	1	Incline Switch	84	1	Rear Endcap
36	2	Wheel Bolt	85	1	Latch Decal
37	2	Wheel	86	1	Rear Roller
38	8	Wheel Nut/Lift Nut	87	1	Upright Plug
39	5	Washer	88	2	Handrail Bolt
40	4	Base Pad	89	2	Latch Screw/Handrail Screw
41	2	Frame Pivot Washer	90	2	Handrail Washer
42	1	Latch Catch	91	2	Rubber Ring
43	1	Reed Switch Clip	#	1	8" White Wire, Pigtail
44	1	Reed Switch	#	1	8" Blue Wire, Pigtail
45	1	Magnet	#	1	8" White Wire, Male/Female
46	1	Console Base	#	1	User's Manual
47	2	Frame Pivot Spacer			
48	4	Platform Screw			
49	4	Isolator			

* Includes all parts shown in the box

These parts are not illustrated

EXPLODED DRAWING—Model No. PFTL39193

R0201A

EXPLODED DRAWING—Model No. PFTL39193

R1201A

