

PRO·FORM[®] EKG

E K G G R I P P U L S E

Model No. PCTL53590

Serial No. _____

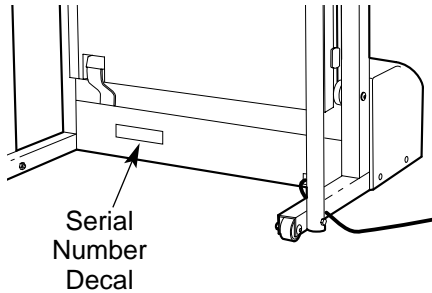

USER'S MANUAL

QUESTIONS?

As a manufacturer, we are committed to providing complete customer satisfaction. If you have questions, or if there are missing or damaged parts, we will guarantee complete satisfaction through direct assistance from our factory.

TO AVOID UNNECESSARY DELAYS, PLEASE CALL DIRECT TO OUR TOLL-FREE CUSTOMER HOT LINE. The trained technicians on our Customer Hot Line will provide immediate assistance, free of charge to you.

CUSTOMER HOT LINE:

1-888-936-4266

Mon.–Fri., 8 a.m.–6:30 p.m. EST
(excluding holidays)



CAUTION

Read all precautions and instructions in this manual before using this equipment. Save this manual for future reference.



Visit our website at

www.proform.com

*new products, prizes,
fitness tips, and much more!*

TABLE OF CONTENTS

IMPORTANT PRECAUTIONS	2
BEFORE YOU BEGIN	4
ASSEMBLY	5
OPERATION AND ADJUSTMENT	8
HOW TO FOLD AND MOVE THE TREADMILL	12
MAINTENANCE AND TROUBLE-SHOOTING	14
CONDITIONING GUIDELINES	16
CUSTOMER RECORD	18
ORDERING REPLACEMENT PARTS	19
LIMITED WARRANTY	Back Cover

Note: An EXPLODED DRAWING and PART LIST are attached in the center of this manual. Please save them for future reference.

IMPORTANT PRECAUTIONS

⚠ WARNING: To reduce the risk of burns, fire, electric shock, or injury to persons, read the following important precautions and information before operating the treadmill.

1. It is the responsibility of the owner to ensure that all users of this treadmill are adequately informed of all warnings and precautions.
2. Use the treadmill only as described in this manual.
3. Place the treadmill on a level surface, with at least eight feet of clearance behind it. Do not place the treadmill on any surface that blocks air openings. To protect the floor or carpet from damage, place a mat under the treadmill.
4. Keep the treadmill indoors, away from moisture and dust. Do not put the treadmill in a garage or covered patio, or near water.
5. Do not operate the treadmill where aerosol products are used or where oxygen is being administered.
6. Keep children under the age of 12 and pets away from the treadmill at all times.
7. The treadmill should not be used by persons weighing more than 250 pounds .
8. Never allow more than one person on the treadmill at a time.
9. Wear appropriate exercise clothing when using the treadmill. Do not wear loose clothing that could become caught in the treadmill. Athletic support clothes are recommended for both men and women. *Always wear athletic shoes. Never use the treadmill with bare feet, wearing only stockings, or in sandals.*
10. When connecting the power cord (see page 8), plug the power cord into a surge suppressor (not included) and plug the surge suppressor into a grounded circuit capable of carrying 15 or more amps. No other appliance should be on the same circuit. Do not use an extension cord.
11. Use only a CUL-listed surge protector, rated at 15 amps, with a 14-gauge cord of five feet or less in length. Do not use an extension cord.
12. Keep the power cord and the surge protector away from heated surfaces.

13. Never move the walking belt while the power is turned off. Do not operate the treadmill if the power cord or plug is damaged, or if the treadmill is not working properly. (See **BEFORE YOU BEGIN** on page 4 if the treadmill is not working properly.)
14. Never start the treadmill while you are standing on the walking belt. Always hold the handrails while using the treadmill.
15. The treadmill is capable of high speeds. Adjust the speed in small increments to avoid sudden jumps in speed.
16. The pulse sensor is not a medical device. Various factors, including the user's movement, may affect the accuracy of heart rate readings. The pulse sensor is intended only as an exercise aid in determining heart rate trends in general.
17. Never leave the treadmill unattended while it is running. Always remove the key when the treadmill is not in use.

18. Do not attempt to raise, lower, or move the treadmill until it is properly assembled. (See **ASSEMBLY** on page 5, and **HOW TO MOVE THE TREADMILL** on page 12.) You must be able to safely lift 45 pounds in order to raise, lower, or move the treadmill.
19. When folding or moving the treadmill, make sure that the storage latch is fully closed.
20. Inspect and tighten all parts of the treadmill regularly.
21. Never insert any object into any opening.
22. **DANGER:** Always unplug the power cord before performing the maintenance and adjustment procedures described in this manual. Never remove the motor hood unless instructed to do so by an authorized service representative. Servicing other than the procedures in this manual should be performed by an authorized service representative only.
23. This treadmill is intended for in-home use only. Do not use this treadmill in any commercial, rental, or institutional setting.

⚠ WARNING: Before beginning this or any exercise program, consult your physician. This is especially important for persons over the age of 35 or persons with pre-existing health problems. Read all instructions before using. ICON assumes no responsibility for personal injury or property damage sustained by or through the use of this product.

SAVE THESE INSTRUCTIONS

The decal shown at the right has been placed on your treadmill. If the decal is missing, or if it is not legible, please call our Customer Service Department, toll-free, to order a free replacement decal (see **ORDERING REPLACEMENT PARTS** on page 19 of this manual). Apply the decal in the location shown.

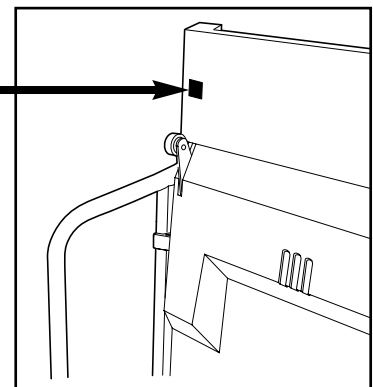

BEFORE YOU BEGIN

Congratulations for purchasing the new PROFORM® EKG treadmill. The PROFORM EKG treadmill combines advanced technology with innovative design to let you enjoy an excellent form of cardiovascular exercise in the convenience and privacy of your home. And when you're not exercising, the unique PROFORM EKG can be folded up, requiring less than half the floor space of other treadmills.



For your benefit, read this manual carefully before using the treadmill. If you have additional questions, please call our Customer Service Department toll-free

at 1-888-936-4266, Monday through Friday, 8 a.m. until 6:30 p.m. Eastern Standard Time (excluding holidays). To help us assist you, please note the product model number and serial number before calling. The model number of the treadmill is PCTL53590. The serial number can be found on a decal attached to the treadmill (see the front cover of this manual for the location).

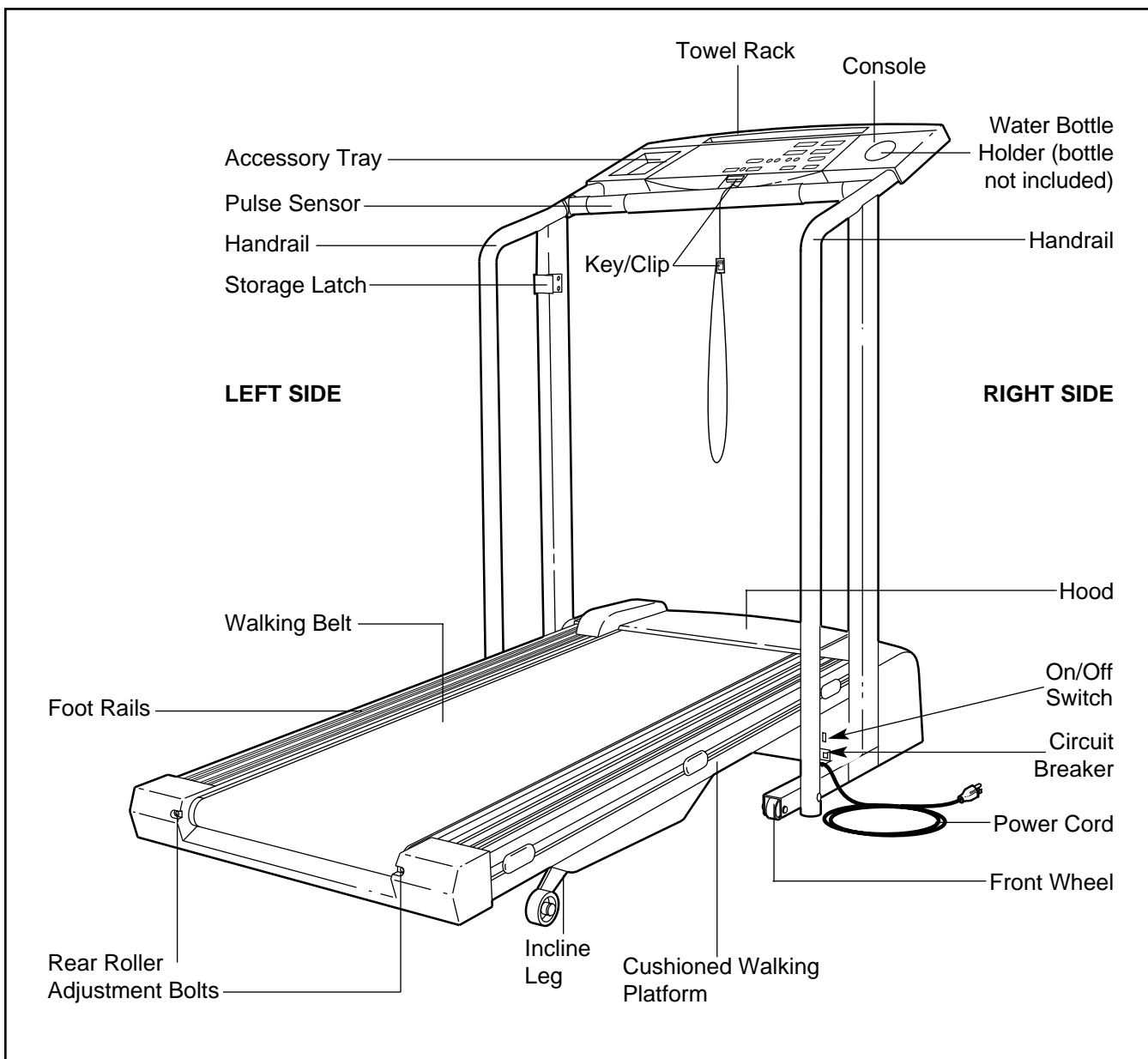
Before reading further, please review the drawing below and familiarize yourself with the labeled parts.

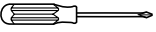

ASSEMBLY

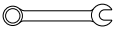
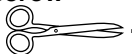
Assembly requires two people. Set the treadmill in a cleared area and remove all packing materials. Do not dispose of the packing materials until assembly is completed. Refer to the drawings below to identify the small parts used in assembly. **Assembly requires the included allen wrench**  **and your own phillips screwdriver** , **adjustable wrench** , **open end wrench**  **and scissors** .

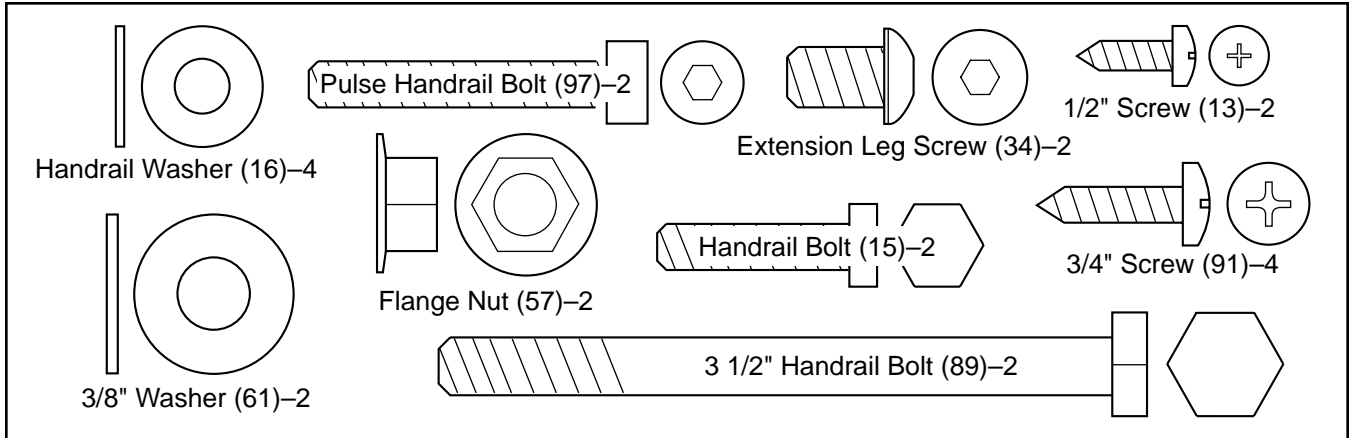

1. With the help of a second person, carefully lay the treadmill on its right side as shown (refer to the drawing on page 4 to identify the right side).

Insert the Extension Legs (41) into the treadmill. Make sure that the Extension Legs are turned so the Base Pads (36) are on the indicated side. Attach each Extension Leg with an Extension Leg Screw (34).

With the help of a second person, carefully raise the treadmill to the upright position so the Extension Legs (41) are resting flat on the floor.

Refer to the inset drawing. Remove the nut, bolt, and shipping bracket from the left Upright (14).

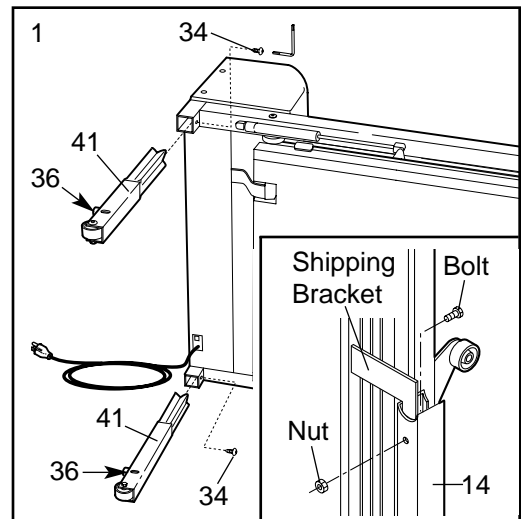

2. Refer to HOW TO LOWER THE TREADMILL FOR USE on page 13. Follow the instructions in step 2 to lower the treadmill.

If there are any plastic ties in the Handrails, cut and remove them.

Position the Left Handrail (2) on the left Upright (14). The lower end of the Left Handrail should be on the outside of the Extension Leg (41) as shown. Note: The Right Handrail will have a "Right" Sticker placed on it. Thread a Handrail Bolt (15) with a Handrail Washer (16) into the left Upright and the Left Handrail. **Do not tighten the Handrail Bolt yet.**

Attach the lower end of the Left Handrail (2) to the Extension Leg (41) with a 3 1/2" Handrail Bolt (89), a 3/8" Washer (61), and a Flange Nut (57). **Do not tighten the Handrail Bolt yet.**

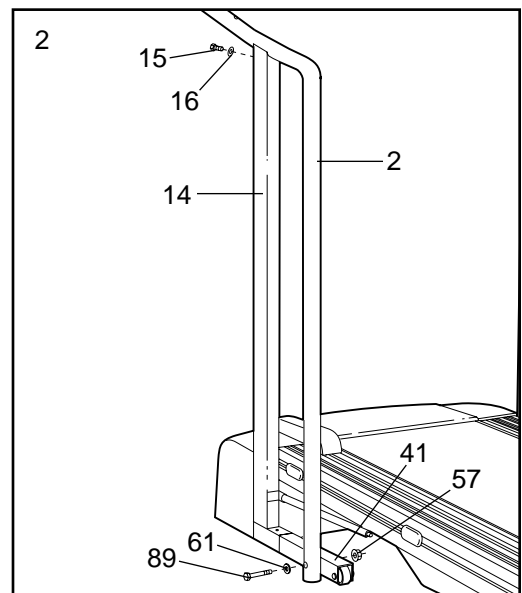

- With the help of a second person, hold the Console Base (6) and the Right Handrail (32) near the right Upright (14) as shown. Route the Console Wire Harness (92) through the bracket on the Right Handrail.

Refer to the inset drawing. Slide the Strain Relief Clip (88) onto the Console Wire Harness (92). Make sure that there is no slack in the Console Wire Harness between the Strain Relief Clip and the Console Base (6). Insert a 3/4" Screw (91) into the Strain Relief Clip and into the indicated hole in the Right Handrail (32). Tighten the Screw into the Console Base.

IMPORTANT: The Strain Relief Clip (88) must be attached as instructed.

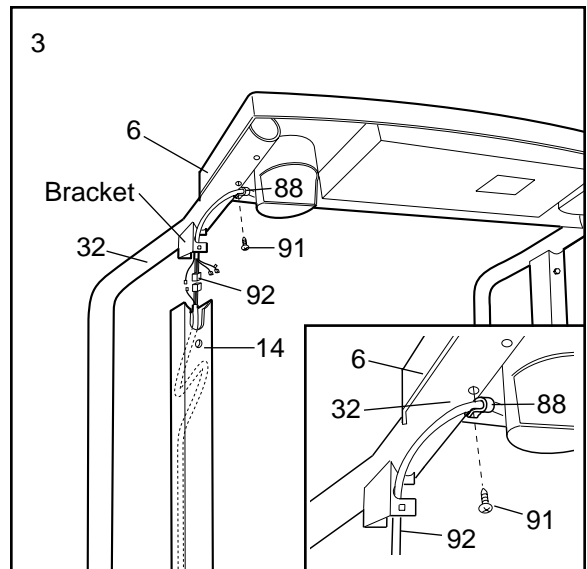

- With the help of a second person, hold the Pulse Handrail (8) near the right Upright (14) as shown. Route the Pulse Wires through the bracket on the Right Handrail (32).

Connect the Console Wire Harness (92) to the Upright Wire Harness (26). Connect the Pulse Wires to the Console Wire Harness (92) as shown in the inset drawing. **Make sure that the wires with tags are connected to each other.**

Position the Pulse Handrail (8) between the Left and Right Handrails (2, 32) as shown. Insert all wires into the right Upright (14). Insert the bracket on the Right Handrail (32) into the right Upright (14). **Make sure that the wires are not pinched.**

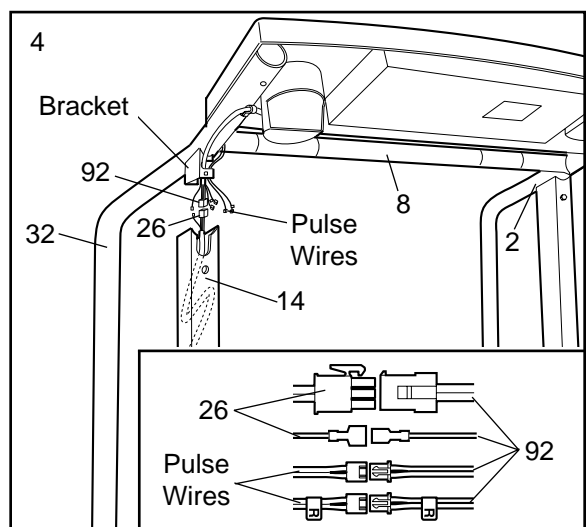

- Using the included allen wrench, attach the Pulse Handrail (8) to the Left and Right Handrails (2, 32) with two Pulse Handrail Bolts (97) and Handrail Washers (16).

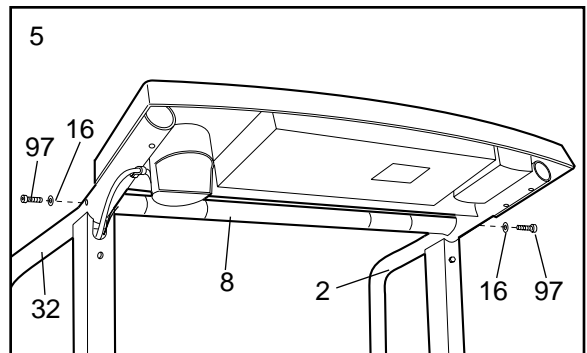

- Attach the Console Base (6) to the Left and Right Handrails (2, 32) with three 3/4" Screws (91).

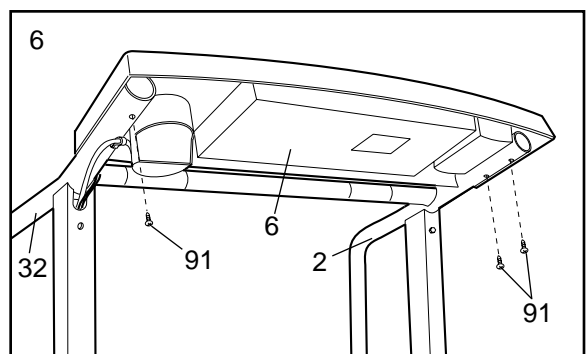

7. Thread a Handrail Bolt (15) with a Handrail Washer (16) into the right Upright (14) and the Right Handrail (32). **Do not tighten the Handrail Bolt yet.**

Attach the lower end of the Right Handrail (32) to the Extension Leg (41) with a 3 1/2" Handrail Bolt (89), a 3/8" Washer (61), and a Flange Nut (57).

Tighten all parts used in this step and in step 2.

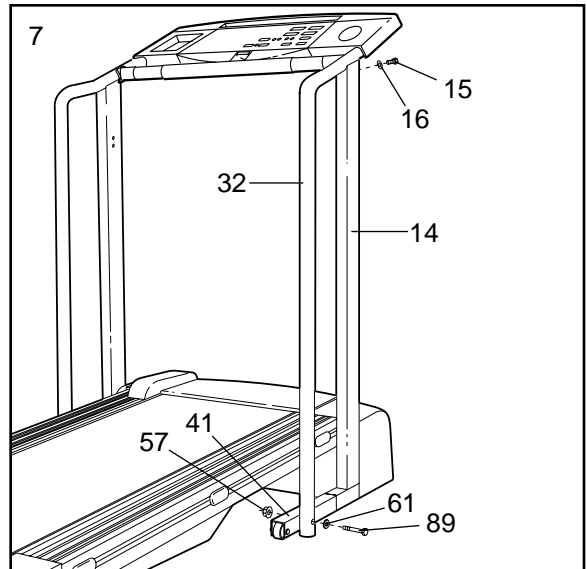

8. Attach the Storage Latch (12) to the left Upright (14) with two 1/2" Screws (13). **Be careful not to overtighten the Screws.**

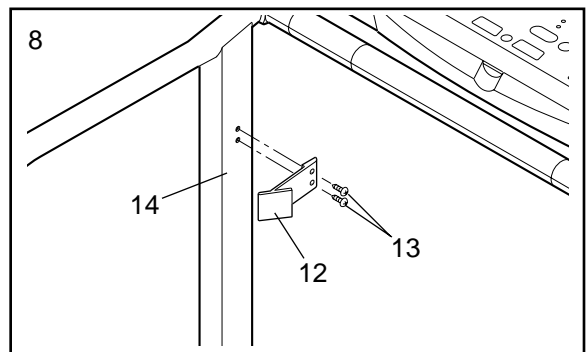

9. Remove the backing from the Adhesive Clip (74). Press the Adhesive Clip onto the base of the Uprights (14) in the indicated location. Press the Allen Wrench (73) into the Adhesive Clip.

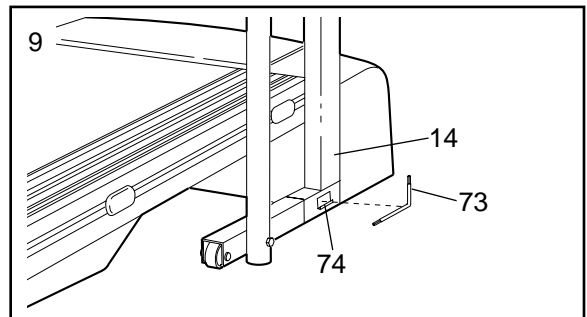

10. **Make sure that all parts are tightened before you use the treadmill. To protect the floor or carpet, place a mat under the treadmill. Note: Some hardware may be left over after assembly is completed.**

OPERATION AND ADJUSTMENT

THE PERFORMANT LUBE™ WALKING BELT

Your treadmill features a walking belt coated with PERFORMANT LUBE™, a high-performance lubricant. **IMPORTANT: Never apply silicone spray or other substances to the walking belt or the walking platform. They will deteriorate the walking belt and cause excessive wear.**

HOW TO PLUG IN THE POWER CORD

⚠ DANGER: Improper connection of the equipment-grounding conductor can result in an increased risk of electric shock. Check with a qualified electrician or serviceman if you are in doubt as to whether the product is properly grounded. Do not modify the plug provided with the product—if it will not fit the outlet, have a proper outlet installed by a qualified electrician.

Your treadmill, like any other type of sophisticated electronic equipment, can be seriously damaged by sudden voltage changes in your home's power. Voltage surges, spikes, and noise interference can result from weather conditions or from other appliances being turned on or off.

To decrease the possibility of your treadmill being damaged, always use a surge protector (not included) with your treadmill.

Surge protectors are sold at most hardware stores and department stores. Use only a CUL-listed surge protector, rated at 15 amps, with a 14-gauge cord of five feet or less in length.

This product must be grounded. If it should malfunction or break down, grounding provides a path of least resistance for electric current to reduce the risk of

electric shock. This product is equipped with a cord having an equipment-grounding conductor and a grounding plug. **Plug the power cord into a surge protector, and plug the surge protector into an appropriate outlet that is properly installed and grounded in accordance with all local codes and ordinances.**

This product is for use on a nominal 120-volt circuit, and has a grounding plug that looks like the plug illustrated in drawing 1 below. A temporary adapter that looks like the adapter illustrated in drawing 2 may be used to connect the surge protector to a 2-pole receptacle as shown in drawing 2 if a properly grounded outlet is not available.

The temporary adapter should be used only until a properly grounded outlet (drawing 1) can be installed by a qualified electrician.

The green-colored rigid ear, lug, or the like extending from the adapter must be connected to a permanent ground such as a properly grounded outlet box cover. Whenever the adapter is used it must be held in place by a metal screw. **Some 2-pole receptacle outlet box covers are not grounded. Contact a qualified electrician to determine if the outlet box cover is grounded before using an adapter.**

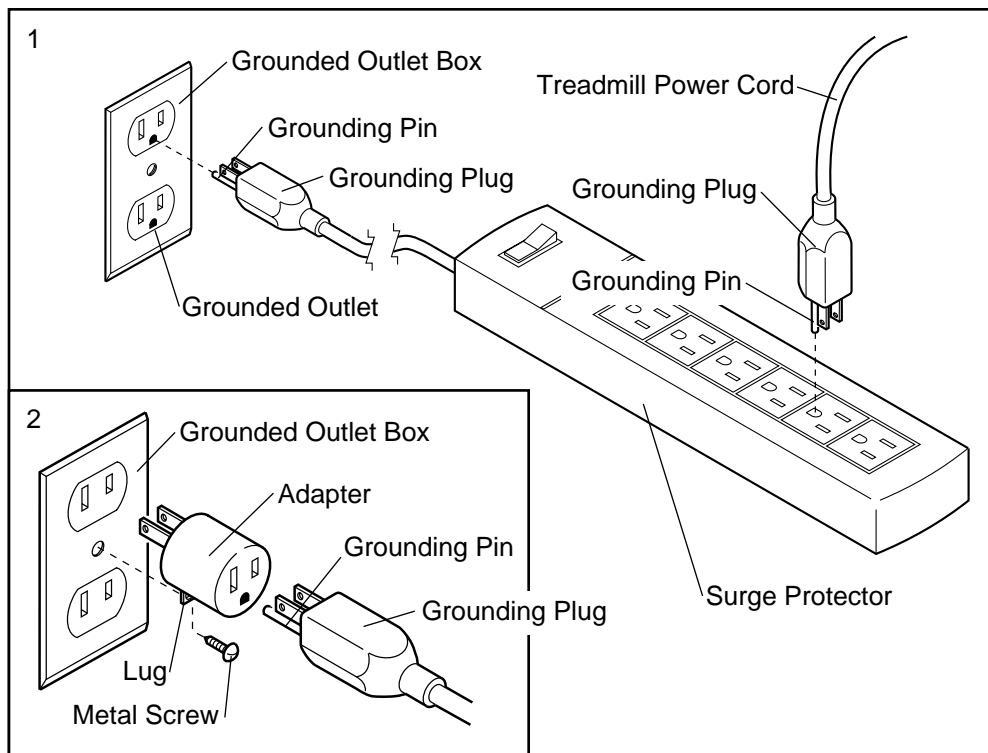

CONSOLE DIAGRAM

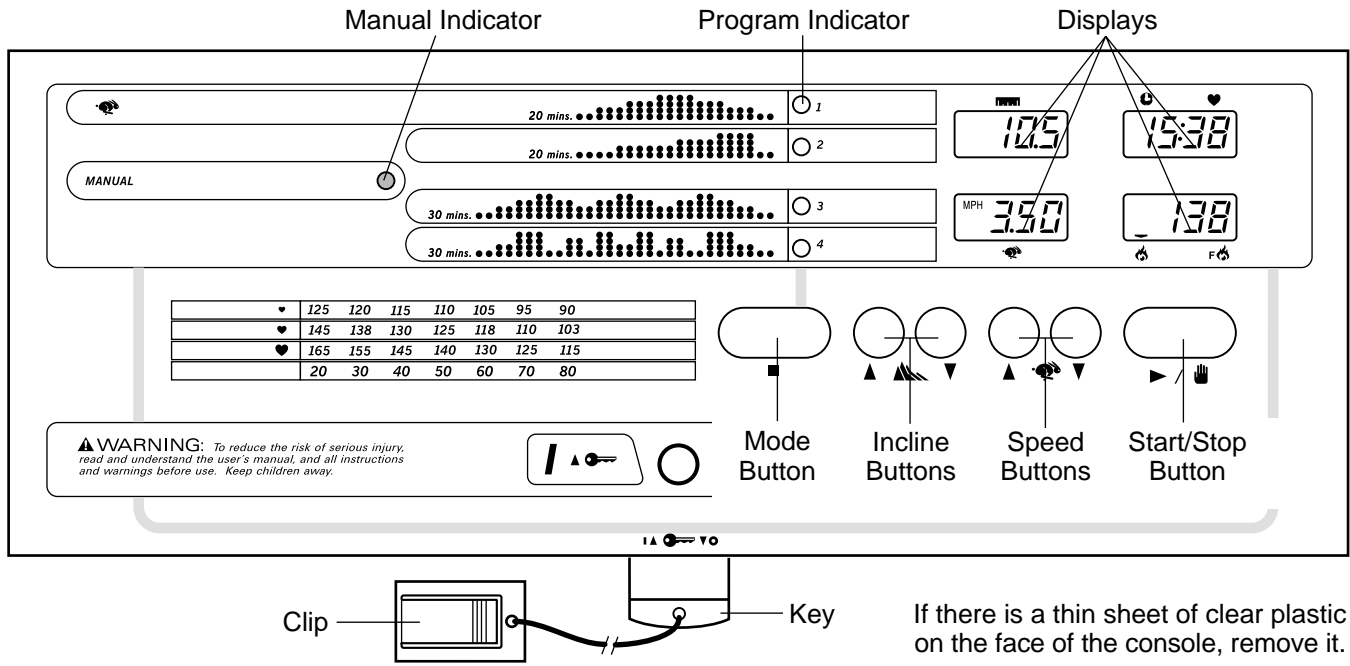

CAUTION: Before operating the console, read the following precautions.

- Do not stand on the walking belt when turning on the power.
- Always wear the clip (see the drawing above) while operating the treadmill.
- Adjust the speed in small increments.
- To reduce the possibility of electric shock, keep the console dry. Avoid spilling liquids on the console, and use only a sealable water bottle.

rate before you begin exercising, during your workout, and again when you finish.

Before operating the console, make sure that the on/off switch, located near the power cord, is in the on position.

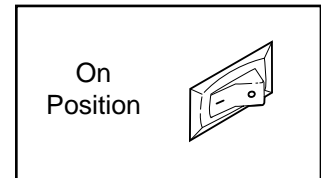

Next, plug in the power cord (see HOW TO PLUG IN THE POWER CORD on page 8). Note: If the key is in the console, remove it before plugging in the power cord.

Step onto the foot rails of the treadmill. Find the clip attached to the key (see the drawing above), and slide the clip onto the waistband of your clothing. Follow the steps below to operate the console.

STEP-BY-STEP CONSOLE OPERATION

The treadmill console features a manual mode and four workout programs. When the manual mode is selected, the speed and incline of the treadmill can be changed with a touch of a button. As you exercise, the four displays will provide continuous exercise feedback. When one of the workout programs is selected, the console will automatically control the speed of the treadmill as it guides you through an effective workout.

In addition, the convenient pulse sensor allows you to monitor your heart rate. You can measure your heart

1 Insert the key fully into the console.

The MANUAL indicator and the four displays will light.

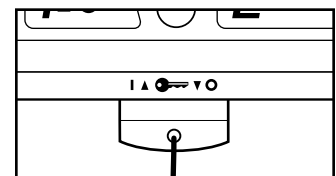

2 Press the mode button to select the desired mode.

When the key is inserted, the manual mode will be selected, as shown by the MANUAL indicator. If a workout program has been selected, press the mode button repeatedly to select the manual mode again.

To select one of the four workout programs, press the mode button. The upper program indicator will light. To select one of the other three programs, press the mode button repeatedly.

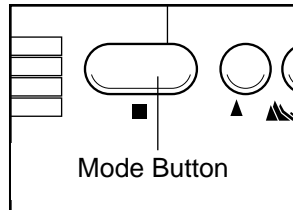

Note: There are two twenty-minute programs and two thirty-minute programs. The graphs in the center of the console show how the speed of the walking belt will change during the programs. During program 1, for example, the speed will gradually increase during the first ten minutes, and then gradually decrease during the last ten minutes. Each program begins with a two-minute warm-up period, and ends with a two-minute cool-down period.

3 Set the desired speed setting.

To start the walking belt at the preset speed setting, go to step 4. To adjust the speed setting before you start the walking belt, follow the instructions below.

If the manual mode is selected: Press the speed Δ button repeatedly to select the desired speed setting. Note: The time/pulse display will flash to indicate that the console has been paused. The walking belt will not begin to move until the start/stop button is pressed (see step 4). **IMPORTANT: Select a low speed setting before starting the walking belt.**

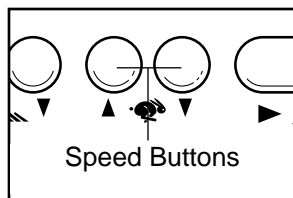

If a workout program is selected: Press the speed Δ or ∇ button. The speed display will begin to flash and a number will appear in the display. This number is the *maximum speed* that the walking belt will reach during the selected program. If desired, press the speed Δ button repeatedly to change the maximum speed setting. If the maximum speed setting is increased, the difficulty level of the entire program will increase. If the maximum speed setting is decreased, the difficulty level of the entire program will decrease. Note: The time/pulse display will flash to indicate that the console has been paused. The walking belt will not begin to move until the start/stop button is pressed (see step 4).

4 Press the start/stop button.

After the start/stop button is pressed, the walking belt will begin to move. Hold the handrails and carefully begin walking.

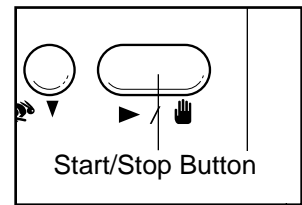

If the console is in the manual mode: As you

exercise, change the speed of the walking belt as desired by pressing the speed buttons.

To stop the walking belt, press the start/stop button. The time/pulse display will begin to flash. To restart the walking belt, press the start/stop button again. To stop the walking belt and reset the displays, press the start/stop button, remove the key from the console, and then reinsert the key.

If a workout program is selected: The speed of the walking belt will change automatically during the program as shown by the graphs in the center of the console. The time remaining in the program will be shown in the time/pulse display. When the program is completed, the walking belt will slow to a stop.

Note: If the program is too difficult or too easy, the difficulty level of the program can be adjusted. Press the speed Δ or ∇ button. The speed display will flash and a number will appear in the display. This number is the *maximum speed* that the walking belt will reach during the program. Press the speed Δ or ∇ button repeatedly to change the maximum speed setting. When the maximum speed setting is increased, the difficulty level of the entire program will increase. When the maximum speed setting is decreased, the difficulty level of the entire program will decrease.

To stop the program for a moment, press the start/stop button. The time/pulse display will begin to flash. To restart the program, press the start/stop button again. To stop the program and reset the displays, press the start/stop button, remove the key from the console, and then reinsert the key. Note: Pressing the mode button will also stop the program, reset the displays, and select a different mode.

5 Change the incline of the treadmill, if desired.

To change the incline, hold down one of the incline buttons until the desired incline is reached.

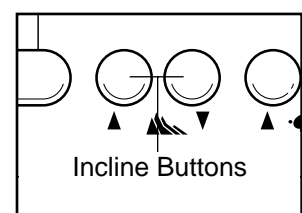

6 Follow your progress with the four displays.

Distance display—This display shows the total distance that you have walked or run.

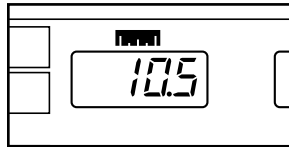

Time/pulse display—When the manual mode is selected, this display shows the elapsed time. When one of the preset programs is selected, the display will show the time remaining in the program. Note: This display will also show your heart rate when you use the pulse sensor (see step 7).

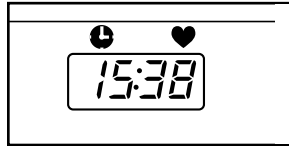

Speed display—This display shows the speed of the walking belt, in miles per hour or kilometers per hour. An MPH or a KPH will appear in the display to show which unit of measurement is selected.



To change the unit of measurement, hold down the start/stop button while inserting the key into the console. An "E" for "English" (miles per hour) or an "M" for "Metric" (kilometers per hour) will appear in the Distance display. Press the speed Δ button to change the unit of measurement. Remove and then reinsert the key.

Cals./fat cals. display—This display shows the approximate numbers of *calories* and *fat calories* you have burned (see FAT BURNING on page 16 for an explanation of fat calories). Every seven seconds, the display will change from one number to the other. An "F" will appear in the display when the number of fat calories is shown.

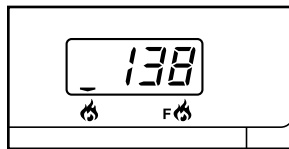

7 Measure your heart rate, if desired.

Stand on the foot rails and place your hands on the metal contacts on the handrail. Your palms must be resting on the upper contacts, and your fingers must be touching the lower contacts—avoid moving your hands while measuring your heart rate. After a moment, a "P" and three dashes "—" will appear in the time/pulse display and your heart rate will be shown. For the most accurate heart rate reading, continue to hold the contacts for about 15 seconds.

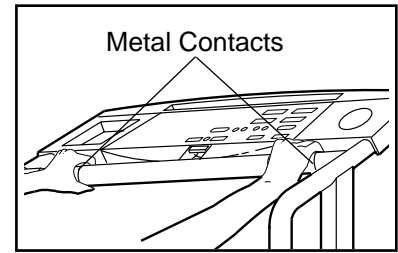

8 When you are finished, remove the key.

Step onto the foot rails and remove the key from the console. Store the key in a secure place. In addition, move the on/off switch to the off position. (See the drawing on page 9.)

PULSE SENSOR TROUBLE-SHOOTING

- Make sure to stand on the foot rails and avoid moving your hands while measuring your heart rate. Excessive movement may interfere with heart rate readings. If the pulse sensor is not used correctly, your heart rate will not be shown.
- Do not hold the metal contacts too tightly; doing so may interfere with heart rate readings.
- For the most accurate heart rate reading, wait for about 15 seconds.
- For optimal performance of the pulse sensor, keep the metal contacts clean. The contacts can be cleaned with a soft cloth—never use alcohol, abrasives, or chemicals.

HOW TO FOLD AND MOVE THE TREADMILL

HOW TO FOLD THE TREADMILL FOR STORAGE

Unplug the power cord. **Caution: You must be able to safely lift 45 pounds in order to raise, lower, or move the treadmill.**

1. Hold the treadmill with your hands in the locations shown at the right. **Caution: To decrease the possibility of injury, bend your legs and keep your back straight. As you raise the treadmill, make sure to lift with your legs rather than your back.** Raise the treadmill about halfway to the vertical position.

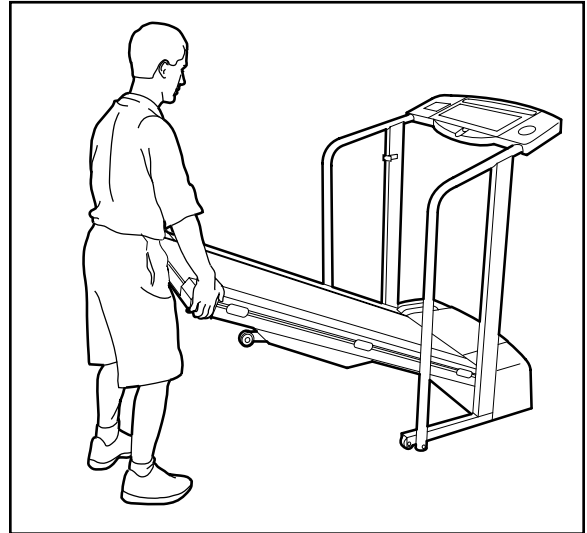

2. Move your right hand to the position shown and hold the treadmill firmly. Press out on the storage latch. Raise the treadmill until the storage latch closes over the catch. **Make sure that the storage latch is closed fully over the catch.**

To protect the floor or carpet from damage, place a mat under the treadmill. Keep the treadmill out of direct sunlight. Do not leave the treadmill in the storage position in temperatures above 85° Fahrenheit.

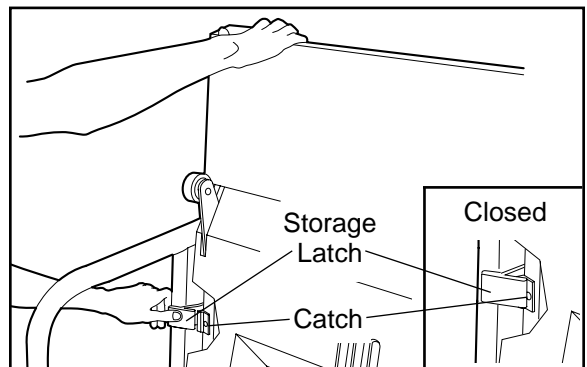

HOW TO MOVE THE TREADMILL

Before moving the treadmill, convert the treadmill to the storage position as described above. **Make sure that the storage latch is closed fully over the catch.**

1. Hold the handrails and place one foot on the base as shown.
2. Tilt the treadmill back until it rolls freely on the front wheels. Carefully move the treadmill to the desired location. **Never move the treadmill without tipping it back, or the base pads may come off. To reduce the risk of injury, use extreme caution while moving the treadmill. Do not attempt to move the treadmill over an uneven surface.**
3. Place one foot on the base, and carefully lower the treadmill until it is resting in the storage position.



HOW TO LOWER THE TREADMILL FOR USE

1. Hold the upper end of the treadmill with your right hand as shown. Using your left thumb, press the storage latch and hold it. Pivot the treadmill until the frame and foot rail are past the storage latch.

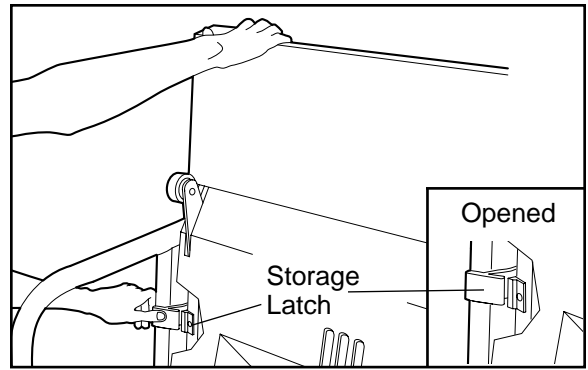

2. Hold the treadmill firmly with both hands, and lower the treadmill to the floor. **Caution: To decrease the possibility of injury, bend your legs and keep your back straight.**

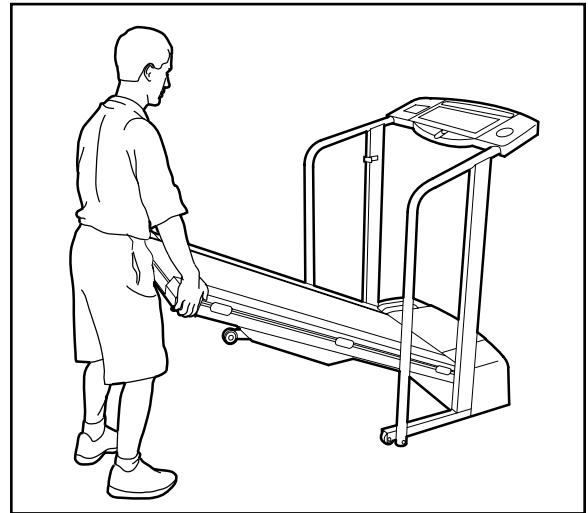

MAINTENANCE AND TROUBLE-SHOOTING

Most treadmill problems can be solved by following the steps below. Find the symptom that applies, and follow the steps listed. If further assistance is needed, please call our Customer Service Department toll-free at 1-888-963-4266, Monday through Friday, 8 a.m. until 6:30 p.m. Eastern Standard Time (excluding holidays).

PROBLEM: The power does not turn on

SOLUTION: a. Make sure that the power cord is plugged into a surge suppressor, and that the surge suppressor is plugged into a properly grounded outlet (see page 8). Use only a CUL-listed surge protector, rated at 15 amps, with a 14-gauge cord of five feet or less in length.

b. After the power cord has been plugged in, make sure that the key is fully inserted into the console. (See step 1 on page 9.)

c. Check the circuit breaker located on the treadmill near the power cord. If the switch protrudes as shown, the circuit breaker has tripped. To reset the circuit breaker, wait for five minutes and then press the switch back in.

d. Check the on/off switch located on the treadmill near the power cord. The switch must be in the on position.

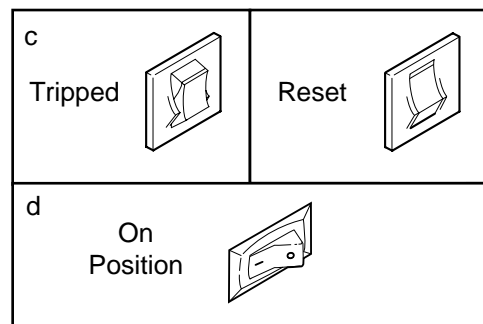

PROBLEM: The power turns off during use

SOLUTION: a. Check the circuit breaker located on the treadmill frame near the power cord (see 1. c. above). If the circuit breaker has tripped, wait for five minutes and then press the switch back in.

b. Make sure that the power cord is plugged in.

c. Remove the key from the console. Reinsert the key fully into the console. (See step 1 on page 9.)

d. Make sure that the on/off switch is in the on position. (See 1. d. above.)

PROBLEM: The displays of the console do not function properly

SOLUTION: a. **Remove the key from the console and UNPLUG THE POWER CORD.** Remove the six screws from the hood. Carefully remove the hood. Locate the Reed Switch (86) and the Magnet (87) on the left side of the Pulley (85). Turn the Pulley until the Magnet is aligned with the Reed Switch. **Make sure that the gap between the Magnet and the Reed Switch is about 1/8".** If necessary, loosen the Screw (35) and move the Reed Switch slightly. Retighten the Screw. Re-attach the hood, and run the treadmill for a few minutes to check for a correct speed reading.

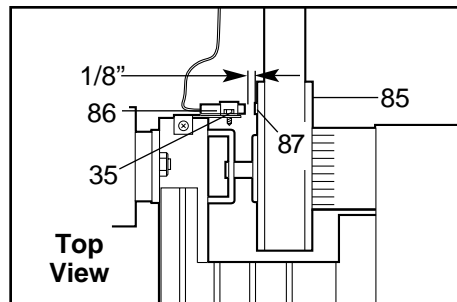

PROBLEM: The walking belt slows when walked on

SOLUTION: a. Use only a CUL-listed surge protector, rated at 15 amps, with a 14-gauge cord of five feet or less in length.

b. If the walking belt is overtightened, treadmill performance may decrease and the walking belt may be permanently damaged. Remove the key and **UNPLUG THE POWER CORD**. Using the allen wrench, turn both rear roller adjustment bolts counterclockwise, 1/4 of a turn. When the walking belt is properly tightened, you should be able to lift each side of the walking belt 3 to 4 inches off the walking platform. Be careful to keep the walking belt centered. Plug in the power cord, insert the key and run the treadmill for a few minutes. Repeat until the walking belt is properly tightened.

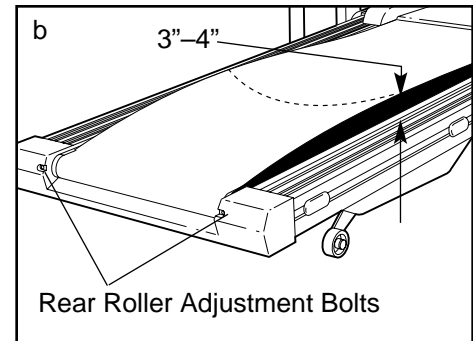

c. If the walking belt still slows when walked on, please call our Customer Service Department, toll-free.

PROBLEM: The walking belt is off-center

SOLUTION: a. **If the walking belt has shifted to the left**, first remove the key and **UNPLUG THE POWER CORD**. Using the allen wrench, turn the left rear roller adjustment bolt clockwise, and the right bolt counterclockwise, 1/4 of a turn each. Be careful not to overtighten the walking belt. Plug in the power cord, insert the key and run the treadmill for a few minutes. Repeat until the walking belt is centered.

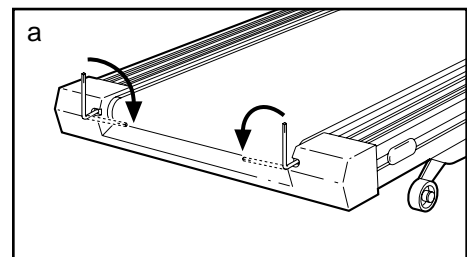

b. **If the walking belt has shifted to the right**, first remove the key and **UNPLUG THE POWER CORD**. Using the allen wrench, turn the left rear roller adjustment bolt counterclockwise, and the right bolt clockwise, 1/4 of a turn each. Be careful not to overtighten the walking belt. Plug in the power cord, insert the key and run the treadmill for a few minutes. Repeat until the walking belt is centered.

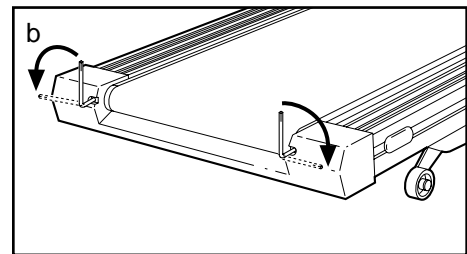

PROBLEM: The walking belt slips when walked on

SOLUTION: a. If the walking belt slips when walked on, first remove the key and **UNPLUG THE POWER CORD**. Using the allen wrench, turn both rear roller adjustment bolts clockwise, 1/4 of a turn. When the walking belt is correctly tightened, you should be able to lift each side of the walking belt 3 to 4 inches off the walking platform. Be careful to keep the walking belt centered. Plug in the power cord, insert the key and run the treadmill for a few minutes. Repeat until the walking belt is properly tightened.

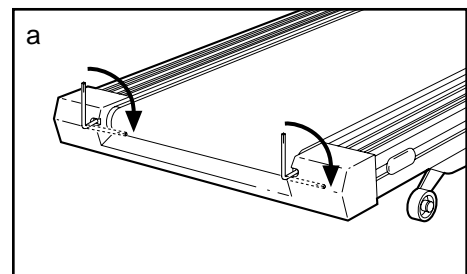

CONDITIONING GUIDELINES

⚠️ WARNING: Before beginning this or any exercise program, consult your physician. This is especially important for individuals over the age of 35 or individuals with pre-existing health problems.

The pulse sensor is not a medical device. Various factors, including your movement, may affect the accuracy of heart rate readings. The sensor is intended only as an exercise aid in determining heart rate trends in general.

The following guidelines will help you to plan your exercise program. Remember—these are general guidelines only. For more detailed exercise information, obtain a reputable book or consult your physician.

EXERCISE INTENSITY

Whether your goal is to burn fat or to strengthen your cardiovascular system, the key to achieving the desired results is to exercise with the proper intensity. The proper intensity level can be found by using your heart rate as a guide. The chart below shows recommended heart rates for fat burning and aerobic exercise.

♥	125	120	115	110	105	95	90
♥	145	138	130	125	118	110	103
♥	165	155	145	140	130	125	115
	20	30	40	50	60	70	80

To find the proper heart rate for you, first find your age on the bottom of the chart (ages are rounded off to the nearest ten years). Next, find the three numbers above your age. The three numbers are your “training zone.” The smaller two numbers are recommended heart rates for fat burning; the larger number is the recommended heart rate for aerobic exercise.

Fat Burning

To burn fat effectively, you must exercise at a relatively low intensity level for a sustained period of time. During the first few minutes of exercise, your body uses easily accessible *carbohydrate calories* for energy. Only after the first few minutes does your body begin to use stored *fat calories* for energy. If your goal is to burn fat, adjust the speed of the treadmill until your heart rate is near the low end of your training zone.

Aerobic Exercise

If your goal is to strengthen your cardiovascular system, your exercise must be “aerobic.” Aerobic exercise is activity that requires large amounts of oxygen for prolonged periods of time. This increases the demand on the heart to pump blood to the muscles, and on the lungs to oxygenate the blood. For aerobic exercise, adjust the speed and incline of the treadmill until your heart rate is near the middle of your training zone.

WORKOUT GUIDELINES

Each workout should include the following three parts:

A Warm-up

Start each workout with 5 to 10 minutes of stretching and light exercise (see **SUGGESTED STRETCHES** on page 17). A proper warm-up increases your body temperature, heart rate, and circulation in preparation for exercise.

Training Zone Exercise

After warming up, increase the intensity of your exercise until your pulse is in your training zone for 20 to 60 minutes. (During the first few weeks of your exercise program, do not keep your pulse in your training zone for longer than 20 minutes.) Breathe regularly and deeply as you exercise—never hold your breath.

A Cool-down

Finish each workout with 5 to 10 minutes of stretching to cool down. This will increase the flexibility of your muscles and will help prevent post-exercise problems.

EXERCISE FREQUENCY

To maintain or improve your condition, complete three workouts each week, with at least one day of rest between workouts. After a few months, you may complete up to five workouts each week if desired.

The key to success is to make exercise a regular and enjoyable part of your everyday life.

SUGGESTED STRETCHES

The correct form for several basic stretches is shown at the right. Move slowly as you stretch—never bounce.

1. Toe Touch Stretch

Stand with your knees bent slightly and slowly bend forward from your hips. Allow your back and shoulders to relax as you reach down toward your toes as far as possible. Hold for 15 counts, then relax. Repeat 3 times. Stretches: Hamstrings, back of knees and back.

2. Hamstring Stretch

Sit with one leg extended. Bring the sole of the opposite foot toward you and rest it against the inner thigh of your extended leg. Reach toward your toes as far as possible. Hold for 15 counts, then relax. Repeat 3 times for each leg. Stretches: Hamstrings, lower back and groin.

3. Calf/Achilles Stretch

With one leg in front of the other, reach forward and place your hands against a wall. Keep your back leg straight and your back foot flat on the floor. Bend your front leg, lean forward and move your hips toward the wall. Hold for 15 counts, then relax. Repeat 3 times for each leg. To cause further stretching of the achilles tendons, bend your back leg as well. Stretches: Calves, achilles tendons and ankles.

4. Quadriceps Stretch

With one hand against a wall for balance, reach back and grasp one foot with your other hand. Bring your heel as close to your buttocks as possible. Hold for 15 counts, then relax. Repeat 3 times for each leg. Stretches: Quadriceps and hip muscles.

5. Inner Thigh Stretch

Sit with the soles of your feet together and your knees outward. Pull your feet toward your groin area as far as possible. Hold for 15 counts, then relax. Repeat 3 times. Stretches: Quadriceps and hip muscles.

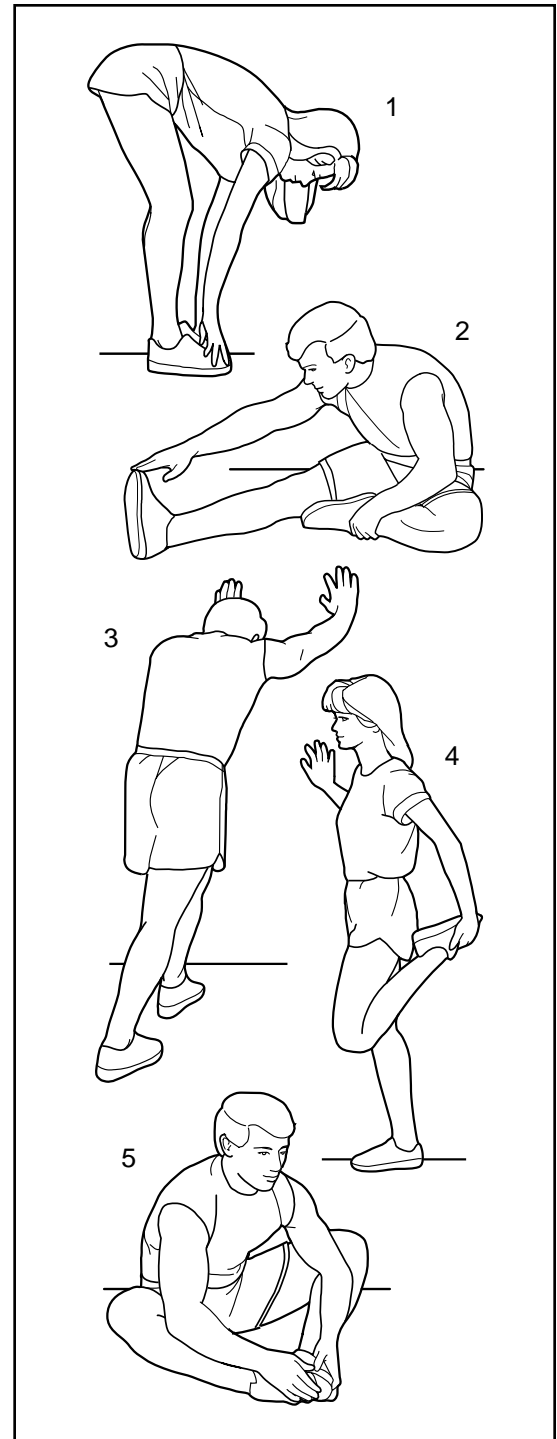

CUSTOMER RECORD

Model No.: _____ Serial No.: _____

Retailer Name: _____ Purchase Date: _____

Retailer Address: _____

ORDERING REPLACEMENT PARTS

To order replacement parts, simply call our Customer Service Department toll-free at 1-888-963-4266 Monday through Friday, 8 a.m. until 6:30 p.m. Eastern Standard Time (excluding holidays). To help us assist you, please be prepared to give the following information when calling:

- The MODEL NUMBER of the product (PCTL53590)
- The NAME of the product (PROFORM EKG)
- The SERIAL NUMBER of the product (see the front cover of this manual)
- The KEY NUMBER and DESCRIPTION of the desired part(s) (see the PART LIST and the EXPLODED DRAWING at the center of this manual).

**PLACE
STAMP
HERE**

ICON of Canada Inc.
900 de l'Industrie
St-Jérôme, Québec
Canada, J7Y 4B8

LIMITED WARRANTY

ICON OF CANADA INC., (ICON), warrants this product to be free from defects in workmanship and material, under normal use and service conditions, for a period of one year from the date of purchase. This warranty extends only to the original purchaser. ICON's obligation under this warranty is limited to replacing or repairing, at ICON's option, the product at one of its authorized service centers. All products for which warranty claim is made must be received by ICON at one of its authorized service centers with all freight and other transportation charges prepaid, accompanied by sufficient proof of purchase. All returns must be pre-authorized by ICON. This warranty does not extend to any product or damage to a product caused by or attributable to freight damage, abuse, misuse, improper or abnormal usage or repairs not provided by an ICON authorized service center, to products used for commercial or rental purposes, or to products used as store display models. No other warranty beyond that specifically set forth above is authorized by ICON.

ICON is not responsible or liable for indirect, special or consequential damages arising out of or in connection with the use or performance of the product or damages with respect to any economic loss, loss of property, loss of revenues or profits, loss of enjoyment or use, costs of removal, installation or other consequential damages of whatsoever nature. Some provinces do not allow the exclusion or limitation of incidental or consequential damages. Accordingly, the above limitation may not apply to you. The warranty extended hereunder is in lieu of any and all other warranties and any implied warranties of merchantability or fitness for a particular purpose is limited in its scope and duration to the terms set forth herein. Some provinces do not allow limitations on how long an implied warranty lasts. Accordingly, the above limitation may not apply to you.

This warranty gives you specific legal rights. You may also have other rights which vary from province to province or so specified by the retailer of your equipment.

ICON OF CANADA, 900 de l'Industrie, St. Jérôme, QC J7Y 4B8

PRO FORM is a registered trademark of ICON Health & Fitness, Inc.



WEIDER PRO-FORM WESLO **PRODUCT WARRANTY REGISTRATION**

IMPORTANT: MAIL WITHIN 14 DAYS OF PURCHASE

NAME: _____ PHONE: _____

ADDRESS: _____

COUNTY: _____ POSTCODE: _____

MODEL NO. _____ SERIAL NO. _____ PURCHASE DATE: _____

RETAILER NAME: _____ RETAILER ADDRESS: _____

<p>1) Primary user(s) of product: <input type="checkbox"/> Male <input type="checkbox"/> Female <input type="checkbox"/> Family</p> <p>2) Age of primary user: <input type="checkbox"/> 0-24 <input type="checkbox"/> 35-44 <input type="checkbox"/> 55-64 <input type="checkbox"/> 25-34 <input type="checkbox"/> 45-54 <input type="checkbox"/> 65 and over</p> <p>3) Annual household income: <input type="checkbox"/> 0-9,999 <input type="checkbox"/> 15,000-19,999 <input type="checkbox"/> 10,000-14,999 <input type="checkbox"/> 20,000+</p> <p>4) How many times a week do you exercise? <input type="checkbox"/> Less than 3 times <input type="checkbox"/> 3 times or more</p> <p>5) Have you ever purchased an ICON product before? <input type="checkbox"/> Yes <input type="checkbox"/> No</p> <p>6) Where did you first see or hear about ICON products? <input type="checkbox"/> Magazine <input type="checkbox"/> Friend/relative <input type="checkbox"/> Newspaper Ad <input type="checkbox"/> Store <input type="checkbox"/> Other</p> <p>7) What was the primary reason for purchasing this ICON product? <input type="checkbox"/> Store Employee <input type="checkbox"/> Television Ads <input type="checkbox"/> Colour <input type="checkbox"/> Electronic Features <input type="checkbox"/> Magazine Ads <input type="checkbox"/> Price <input type="checkbox"/> Product Design <input type="checkbox"/> Product Innovation <input type="checkbox"/> Other Features</p>	<p>8) Did you consider purchasing fitness equipment from another manufacturer? <input type="checkbox"/> No <input type="checkbox"/> Yes What other Manufacturer? _____</p> <p>9) Based on your impression of what you have purchased, would you buy another ICON product? <input type="checkbox"/> Yes <input type="checkbox"/> No <input type="checkbox"/> No Opinion If not, what other brand name equipment would you purchase? _____</p> <p>10) What other type of exercise equipment do you own? <input type="checkbox"/> Bicycle <input type="checkbox"/> Exercise Cycle <input type="checkbox"/> Treadmill <input type="checkbox"/> Home Gym <input type="checkbox"/> Weight Bench <input type="checkbox"/> Stepper <input type="checkbox"/> Cardio Glide <input type="checkbox"/> Other</p> <p>11) Which type of magazines do you read regularly? <input type="checkbox"/> Sports <input type="checkbox"/> Fitness <input type="checkbox"/> Motoring <input type="checkbox"/> Business <input type="checkbox"/> Computer <input type="checkbox"/> General</p> <p>12) Do you wish to be sent further bulletins about ICON products? <input type="checkbox"/> Yes <input type="checkbox"/> No</p>
---	--

THANK YOU FOR YOUR TIME

© 2002 ICON of Canada, Inc. Printed in Canada



**REMOVE THIS EXPLODED DRAWING
AND PART LIST FROM THE MANUAL.
Save this page for future reference.**

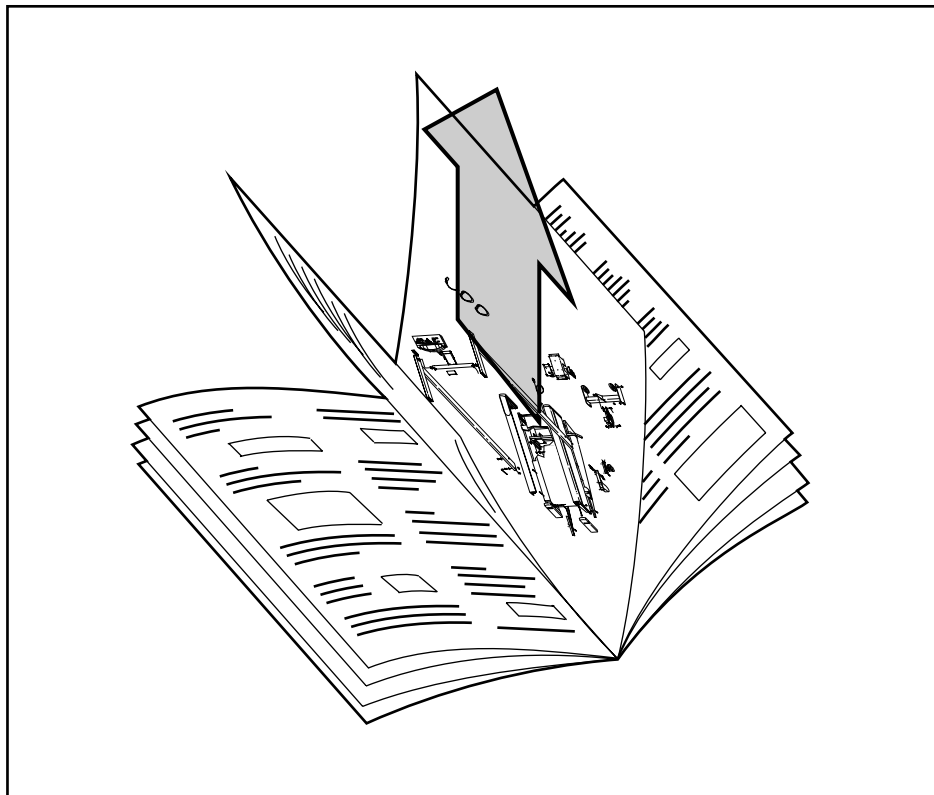

Note: Specifications are subject to change without notice. For information about ordering replacement parts, see page 19 of the User's Manual.

PART LIST—Model No. PCTL53590

R0602A

Key No.	Qty.	Description			
			54	1	Motor Belly Pan
			55	1	11 1/2" Cable Tie
1	1	Key/Clip	56	11	8" Cable Tie
2	1	Left Handrail	57	2	Flange Nut
3	2	Cage Nut	58	1	On/Off Switch
4	4	Stand Off	59	1	Electronics Plate
5	4	Rear Isolator Screw	60	1	Incline Extension
6	1	Console Base	61	4	3/8" Washer
7	1	8" Wire Harness	62	2	Solid Isolator
8	1	Pulse Handrail Assembly	63	7	Incline Nut
9	2	Battery Cover	64	2	Incline Wheel Bolt
10	1	Incline Motor	65	2	Incline Wheel
11*	1	Console Assembly	66	2	Incline Wheel Nut
12	1	Storage Latch	67	2	Small Washer
13	2	1/2" Screw	68	1	Ground Wire
14	1	Upright/Base	69	1	Incline Leg
15	2	Handrail Bolt	70	1	Power Board w/Stand-Offs
16	9	Handrail Washer	71	2	Rear Roller Adj. Bolt
17	1	Motor Belt	72	1	Rear Roller Endcap
18	1	Motor Swivel Nut	73	1	Allen Wrench
19*	1	Motor/Pulley/Flywheel/Fan	74	1	Adhesive Clip
20	1	Pulley/Flywheel/Fan	75	1	Left Foot Rail
21	1	Motor	76	1	Rear Roller
22	4	Motor Tension Bolt/Incline Bolt	77	4	Platform Screw
23	1	Motor Tension Washer	78	1	Latch Catch
24	1	Motor Tension Star Washer	79	1	Walking Platform
25	1	Motor Swivel Bolt	80	1	Walking Belt
26	1	Upright Wire Harness	81	1	Front Roller Adjustment Bolt
27	2	Ground Wire Screw	82	1	Shock
28	1	Hood	83	1	Right Foot Rail
29	1	Hood Shield	84	1	Sensor Clip
30	11	Screw	85	1	Front Roller/Pulley
31	1	Latch Decal	86	1	Reed Switch
32	1	Right Handrail	87	1	Magnet
33	2	Frame Pivot Bolt	88	1	Strain Relief Clip
34	2	Extension Leg Screw	89	2	3 1/2" Handrail Bolt
35	35	Electronics Screw	90	1	Frame
36	4	Base Pad	91	4	3/4" Screw
37	2	Wheel Bolt	92	1	Console Wire Harness
38	2	Wheel	93	10	Reed Switch/Hood Screw
39	4	Wheel Nut/Base Pivot Nut	94	1	Reed Switch Bracket
40	1	Controller	95	2	Roller Guard
41	2	Extension Leg	96	1	51" Incline Wire Harness
42	1	Circuit Breaker	97	2	Pulse Handrail Bolt
43	1	Power Cord Grommet	#	1	8" Blue Wire, Male/Female
44	1	Power Cord	#	1	8" Blue Wire, 2 Female
45	2	Upright Spacer	#	1	4" Blue Wire, 2 Female
46	4	Isolator	#	1	14" White Wire, Pig Tail
47	12	Belly Pan Fastener	#	1	8" White Wire, 2 Female
48	1	Choke	#	1	30" Black Wire, Male/Female
49	1	Motor Locknut	#	1	20" Black Wire, 2 Female
50	2	Belt Guide	#	1	8" Ground Wire, Female/Ring
51	1	Belly Pan	#	1	8" Red Wire, Male/Female
52	2	Releasable Tie	#	1	User's Manual
53	4	Cable Tie Clamp			

* Includes all parts shown in the box

Note: “#” indicates a non-illustrated part. Specifications are subject to change without notice. See page 19 of the user's manual for information about ordering replacement parts.

EXPLODED DRAWING—Model No. PCTL53590

R0602A

