

PRO-FORM[®] CrossTrainer

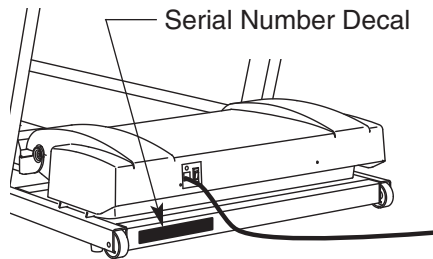

Model No. DTL44950

Serial No. _____



USER'S MANUAL

QUESTIONS?

If you have questions, or if there are missing or damaged parts, we will guarantee complete satisfaction through direct assistance from our factory.

TO AVOID DELAYS, PLEASE CALL DIRECT TO OUR TOLL-FREE CUSTOMER HOT LINE. The trained technicians on our Customer Hot Line will provide immediate assistance, free of charge to you.

CUSTOMER HOT LINE:

1-888-533-1333

Mon.-Fri., 6 a.m.-6 p.m. MST

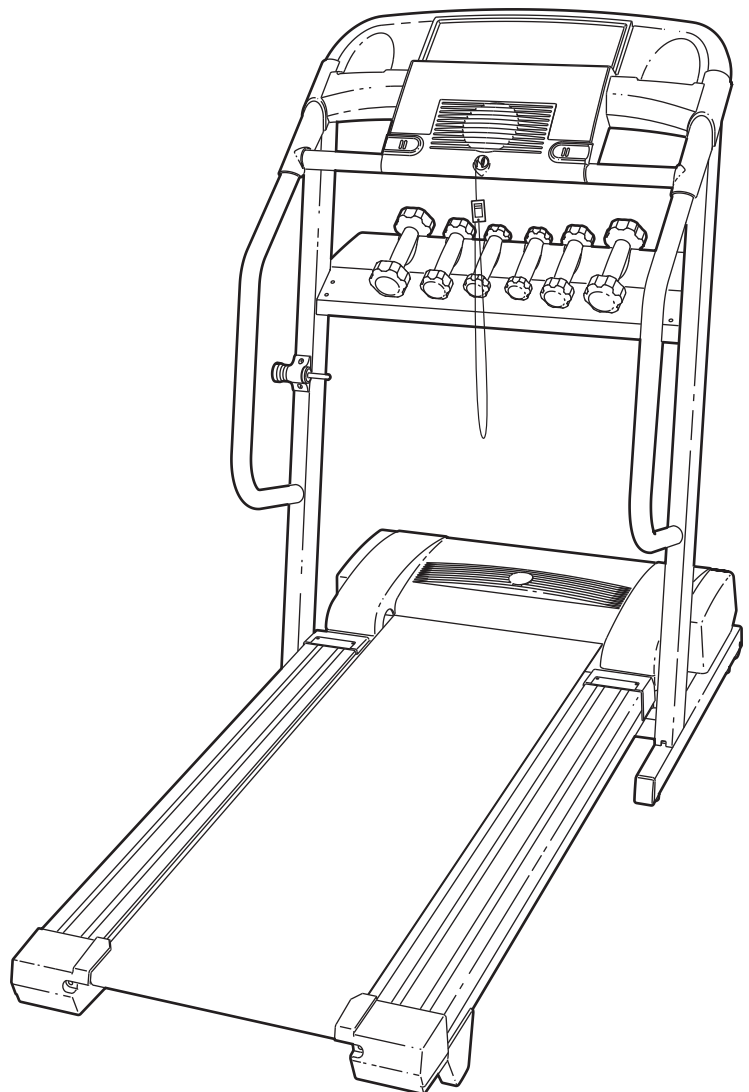

CAUTION

Read all precautions and instructions in this manual before using this equipment. Save this manual for future reference.



Visit our website at

www.proform.com

new products, prizes,
fitness tips, and much more!

PRO-FORM[®] **CrossTrainer**



TABLE OF CONTENTS

IMPORTANT PRECAUTIONS	3
BEFORE YOU BEGIN	5
ASSEMBLY	6
OPERATION AND ADJUSTMENT	10
HOW TO FOLD AND MOVE THE TREADMILL	21
TROUBLESHOOTING	23
CONDITIONING GUIDELINES	25
PART LIST	28
EXPLODED DRAWING	29
ORDERING REPLACEMENT PARTSBack Cover
LIMMITED WARRANTYBack Cover

IMPORTANT PRECAUTIONS

⚠ WARNING: To reduce the risk of burns, fire, electric shock, or injury to persons, read the following important precautions and information before operating the treadmill.

1. It is the responsibility of the owner to ensure that all users of this treadmill are adequately informed of all warnings and precautions.
2. Use the treadmill only as described in this manual.
3. Place the treadmill on a level surface, with at least eight feet of clearance behind it and two feet on each side. Do not place the treadmill on any surface that blocks air openings. To protect the floor or carpet from damage, place a mat under the treadmill.
4. Keep the treadmill indoors, away from moisture and dust. Do not put the treadmill in a garage or covered patio, or near water.
5. Do not operate the treadmill where aerosol products are used or oxygen is administered.
6. Keep children under the age of 12 and pets away from the treadmill at all times.
7. The treadmill should not be used by persons weighing more than 300 pounds. Never allow more than one person on the treadmill at a time.
8. Wear appropriate exercise clothes when using the treadmill. Do not wear loose clothes that could become caught in the treadmill. Athletic support clothes are recommended for both men and women. *Always wear athletic shoes. Never use the treadmill with bare feet, wearing only stockings, or in sandals.*
9. When connecting the power cord (see page 10), plug the power cord into a surge suppressor (not included) and plug the surge suppressor into a grounded circuit capable of carrying 15 or more amps. No other appliance should be on the same circuit. Do not use an extension cord.
10. Use only a single-outlet surge suppressor that meets all of the specifications described on page 10. To purchase a surge suppressor, see your local PROFORM dealer or call 1-888-533-1333 and order part number 146148, or see your local electronics store.
11. Failure to use a properly functioning surge suppressor could result in damage to the control system of the treadmill. If the control system is damaged, the walking belt may change speed, accelerate, or stop unexpectedly, which may result in a fall and serious injury.
12. Keep the power cord and the surge suppressor away from heated surfaces.
13. Never move the walking belt while the power is turned off. Do not operate the treadmill if the power cord or plug is damaged, or if the treadmill is not working properly. (See **BEFORE YOU BEGIN** on page 5 if the treadmill is not working properly.)
14. Never start the treadmill while you are standing on the walking belt. Always hold the handrails while using the treadmill.
15. The treadmill is capable of high speeds. Adjust the speed in small increments to avoid sudden jumps in speed.
16. The pulse sensor is not a medical device. Various factors, including the user's movement, may affect the accuracy of heart rate readings. The pulse sensor is intended only as an exercise aid in determining heart rate trends in general.
17. Never leave the treadmill unattended while it is running. Always remove the key, unplug the power cord, and move the reset/off circuit breaker to the off position when the treadmill is not in use. (See the drawing on page 5 for the location of the circuit breaker.)
18. Do not use the hand weights at speeds faster than walking speeds. Using weights and not holding the handrails may compromise your ability to maintain your balance. Exercises using weights should be attempted only by experienced users.
19. Do not attempt to raise, lower, or move the treadmill until it is properly assembled. (See **ASSEMBLY** on page 6, and **HOW TO FOLD AND MOVE THE TREADMILL** on page 21.) You must be able to safely lift 45 pounds (20 kg) to raise, lower, or move the treadmill.
20. When folding or moving the treadmill, make sure that the storage latch is fully closed.

21. When using iFIT.com CDs and videos, an electronic “chirping” sound will alert you when the speed of the treadmill is about to change. Always listen for the “chirp” and be prepared for speed changes. In some instances, the speed may change before the personal trainer describes the change.

22. When using iFIT.com CDs and videos, you can manually override the speed setting at any time by pressing the speed buttons. However, when the next “chirp” is heard, the speed will change to the next setting of the CD or video program.

23. Always remove iFIT.com CDs and videos from your CD player or VCR when you are not using them.

24. Inspect and properly tighten all parts of the

treadmill every three months.

25. Never drop or insert any object into any opening.

26. **DANGER:** Always unplug the power cord immediately after use, before cleaning the treadmill, and before performing the maintenance and adjustment procedures described in this manual. Never remove the motor hood unless instructed to do so by an authorized service representative. Servicing other than the procedures in this manual should be performed by an authorized service representative only.

27. The treadmill is intended for in-home use only. Do not use the treadmill in any commercial, rental, or institutional setting.

! WARNING: Before beginning this or any exercise program, consult your physician. This is especially important for persons over the age of 35 or persons with pre-existing health problems. Read all instructions before using. ICON assumes no responsibility for personal injury or property damage sustained by or through the use of this product.

SAVE THESE INSTRUCTIONS

The decals shown have been placed on your treadmill. If a decal is missing, or if it is not legible, please call toll-free 1-888-533-1333 to order a free replacement decal. Apply the decal in the location shown. Note: The decals are not shown at actual size.

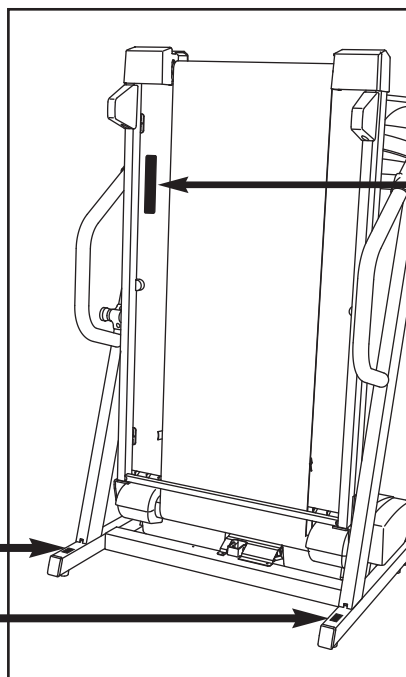

! WARNING:

Protect yourself and others from risk of serious injury. Read the user's manual and:



- Stand only on the side rails when starting or stopping treadmill.

- Change speed in small increments.

- Hold handrails to prevent falling, and always wear the safety clip while operating treadmill.

- Stop if you feel faint, dizzy, or short of breath.

- Fully engage storage latch before treadmill is moved or stored.

- Reduce incline to its lowest level before folding treadmill into storage position.



- Never allow children on or around treadmill.

- Remove key when not in use.



- Keep clothing, fingers, and hair away from moving belt.

- Never try to adjust or fix the belt while it is moving.

- Always wear athletic shoes while operating treadmill.

BEFORE YOU BEGIN

Thank you for selecting the revolutionary PROFORM® CROSS TRAINER VX treadmill. The CROSS TRAINER VX treadmill combines advanced technology with innovative design to help you get the most from your exercise program in the convenience and privacy of your home. And when you're not exercising, the unique CROSS TRAINER VX treadmill can be folded up, requiring less than half the floor space of other treadmills.



For your benefit, read this manual carefully before using the treadmill. If you have questions after reading this manual, please call our Customer Service

Department toll-free at 1-888-533-1333, Monday through Friday, 6 a.m. until 6 p.m. Mountain Time (excluding holidays). To help us assist you, please note the product model number and serial number before calling. The model number of the treadmill is DTL44950. The serial number can be found on a decal attached to the treadmill (see the front cover of this manual for the location).

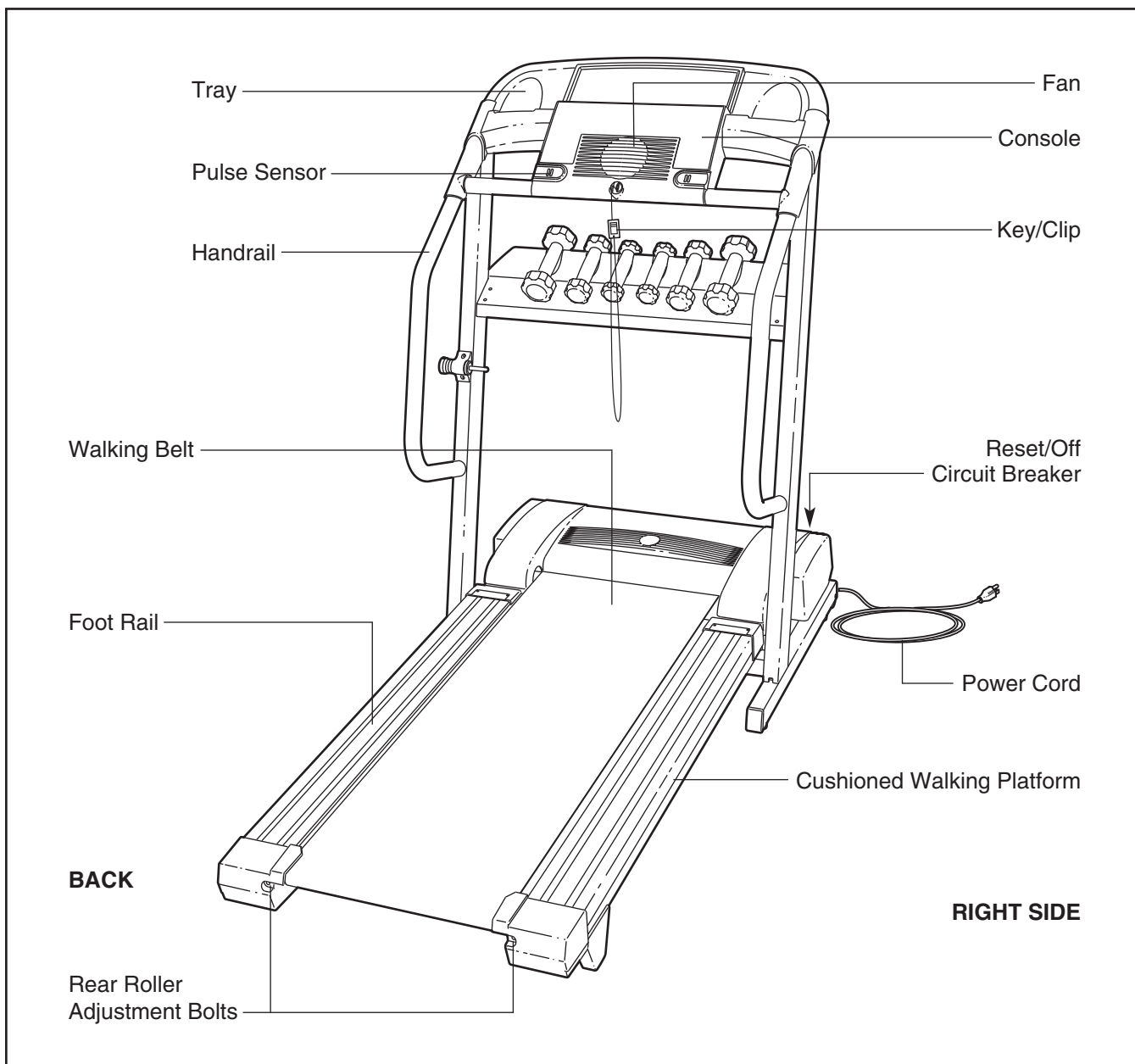
Before reading further, please review the drawing below and familiarize yourself with the labeled parts.

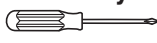

ASSEMBLY

Assembly requires two persons. Set the treadmill in a cleared area and remove all packing materials. Do not dispose of the packing materials until assembly is completed. **Assembly requires the included allen wrench and 90° screwdriver**  **and your own Phillips screwdriver**  **and needlenose pliers** .

Note: The underside of the treadmill walking belt is coated with high-performance lubricant. During shipping, a small amount of lubricant may be transferred to the top of the walking belt or the shipping carton. This is a normal condition and does not affect treadmill performance. If there is lubricant on top of the walking belt, simply wipe off the lubricant with a soft cloth and a mild, non-abrasive cleaner.

For help identifying the assembly hardware, see the drawings below. Note: The assembly hardware and other small parts are packaged in separate part bags.

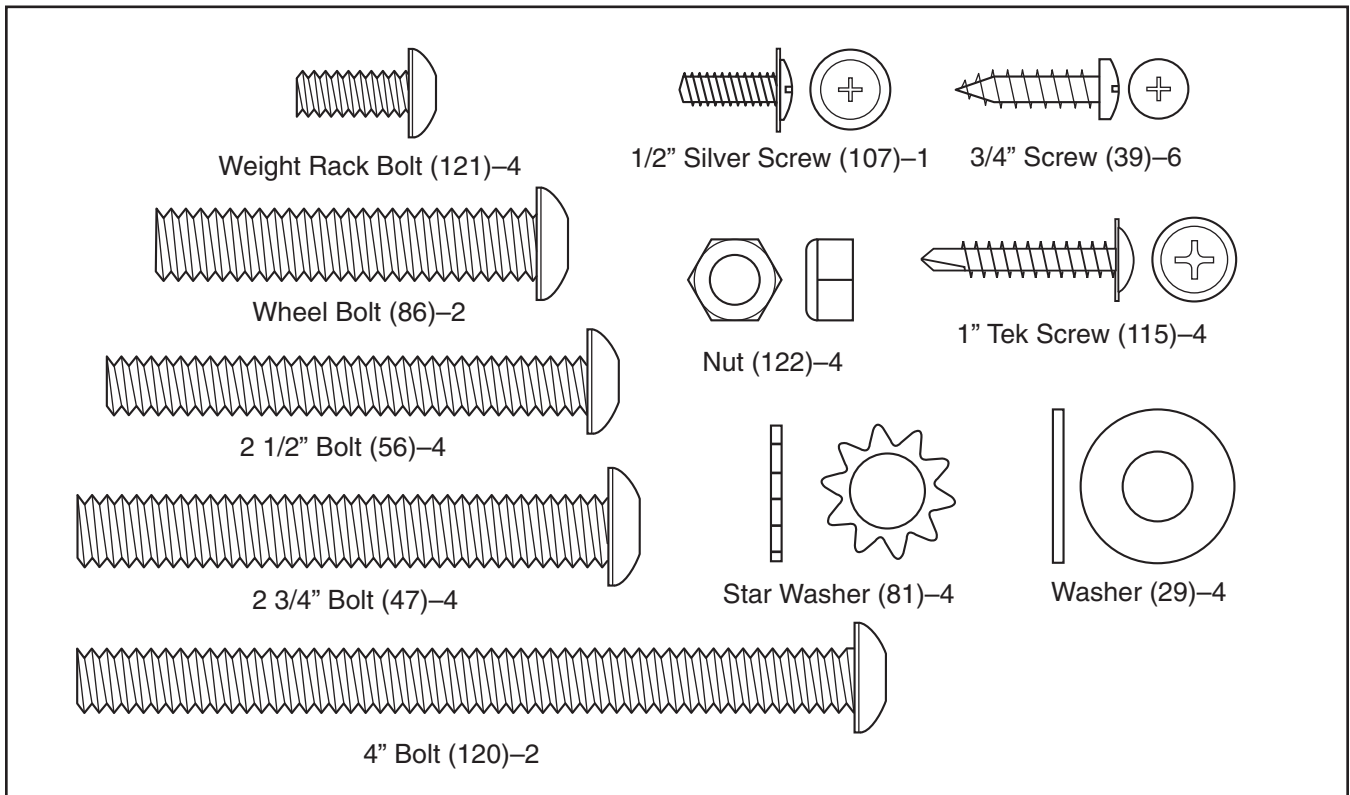

1. Make sure that the power cord is not plugged in.

With the help of a second person, carefully tip the treadmill onto its left side. Partially fold the Frame (12) so that the treadmill will be more stable. **Do not fully fold the treadmill until it is completely assembled.**

Attach the four Base Pads (97) to the bottom of the Base (82) with four 1" Tek Screws (115) (only two Base Pads and 1" Tek Screws are shown).

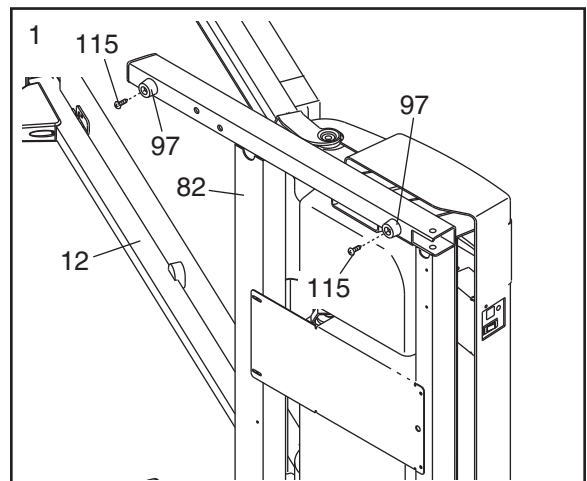

2. Identify the Right Upright (10). Note: The Left Upright (9) has the Latch Housing (77, see step 3) attached to it.

Have a second person hold the Right Upright (10) near the Base (82) as shown. Orient the Right Upright so that it is angled forward (see step 3). Feed the Upright Wire Harness (17) into the lower end of the Right Upright and out of the upper end.

Next, hold the Right Upright (10) against the Base (82). **Be careful not to pinch the wires.** Insert two 2 3/4" Bolts (47), with two Washers (29) and two Star Washers (81), into the Base, and **loosely thread** the Bolts into the lower end of the Right Upright (10).

Attach a Wheel (95) to the Base (82) with a Wheel Bolt (86). **Do not overtighten the Wheel Bolt; the Wheel must be able to turn freely.**

With the help of a second person, tip the treadmill onto its right side. **Be careful not to damage the Upright Wire Harness (17).** Have a second person hold the Left Upright (9) near the Base (82). Orient the Left Upright so that it is angled forward (see step 3). Attach the Left Upright and the other Wheel (not shown) as described above. Note: There are no wires in the Left Upright.

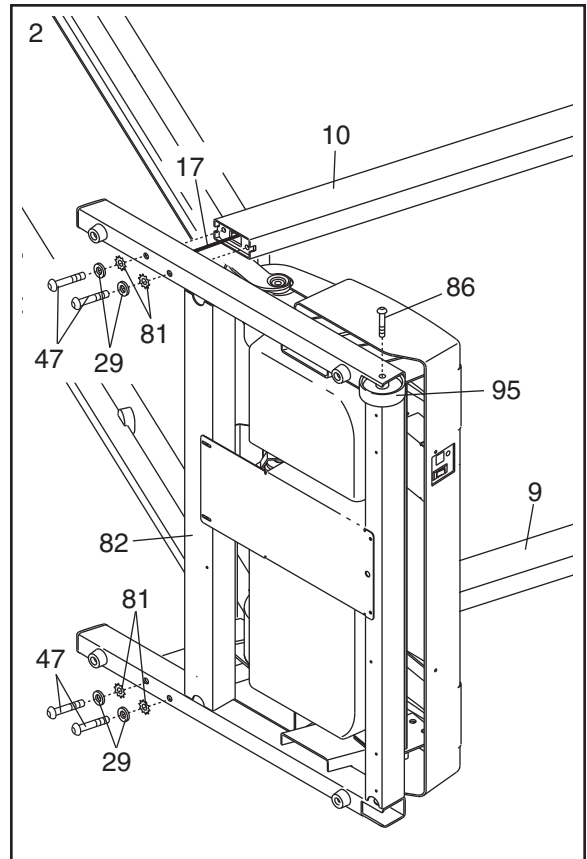

3. With the help of a second person, set the treadmill on the floor with the Left and Right Uprights (9, 10) vertical.

Identify the Right Handrail (124), which has a large hole in the left side. Feed the Wire Harness (17) up through the hole in the bottom of the Right Handrail and out of the large hole in the left side. Note: It may be helpful to use needlenose pliers to pull the Wire Harness out of the large hole.

Set the Right Handrail (124) on the Right Upright (10). Finger tighten a 4" Bolt (120) through the Right Upright into the lower end of the Right Handrail. Attach the upper end of the Right Handrail with a 2 1/2" Bolt (56). **Do not tighten the Bolts yet.**

Attach the Left Handrail (123) as described above. Note: There is not a wire in the Left Handrail.

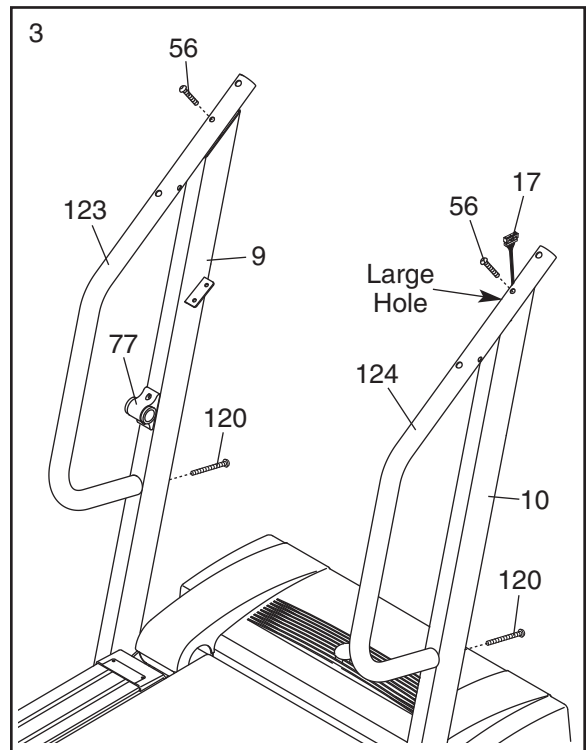

4. Hold the Crossbar (88) between the Handrails (123, 124). Make sure that the square hole in the Crossbar is on top as shown. Attach the Crossbar with two 2 1/2" Bolts (56). **Do not tighten the Crossbar Bolts yet.**

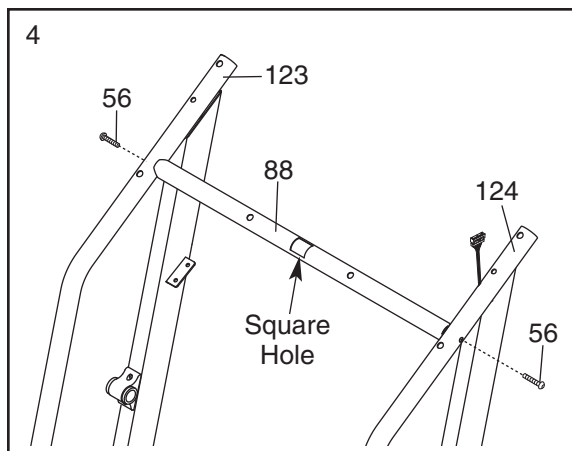

5. Attach the Weight Rack (125) to the brackets on the Left and Right Uprights (9, 10) with four Weight Rack Bolts (121) and four Nuts (122). **Attach all of the Weight Rack Bolts and Nuts before tightening any of them.**

Firmly tighten the four 2 1/2" Bolts (56). Next, firmly tighten the two 4" Bolts (120).

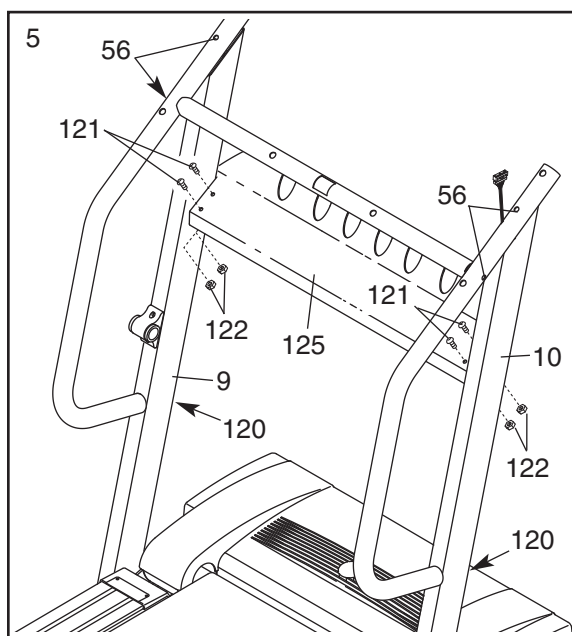

6. Have a second person hold the Console (78) near the Right Upright (10). Attach the ground wire from the Console to the Right Upright with the 1/2" Silver Screw (107).

Connect the Upright Wire Harness (17) to the wire harness on the Console (78). **Make sure to connect the connectors properly (see the inset drawing). The connectors should slide together easily and snap into place. IF THE CONNECTORS ARE NOT CONNECTED PROPERLY, THE CONSOLE MAY BE DAMAGED WHEN THE POWER IS TURNED ON.** Insert the connectors into the Console.

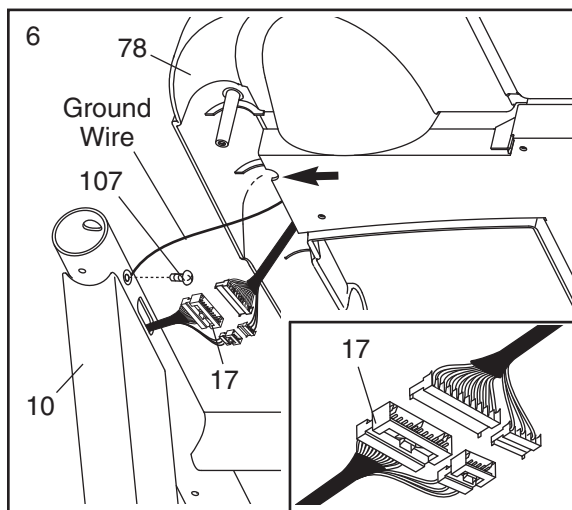

- Set the Console (78) on the Left and Right Uprights (9, 10). **Be careful not to pinch any wires.** See drawing 6 on page 8. Make sure that the Upright Wire Harness (17) is **not** in the small cutout shown by the arrow.

Using the included 90° screwdriver and a phillips screwdriver, attach the Console (78) to the Uprights (9, 10) and the Crossbar (88) with six 3/4" Screws (39). **Start all six Screws before tightening any of them; be careful not to overtighten the Screws.**

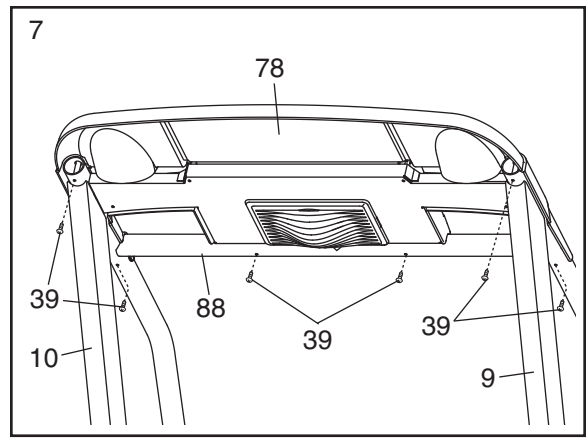

- Lower the Uprights (9, 10) until the handrails are touching the floor.

See the lower drawing. Position the Uprights (9, 10) so that the treadmill Frame (12) is centered between the Uprights.

Firmly tighten the four 2 3/4" Bolts (47). Then, raise the Uprights (9, 10) back to the vertical position.

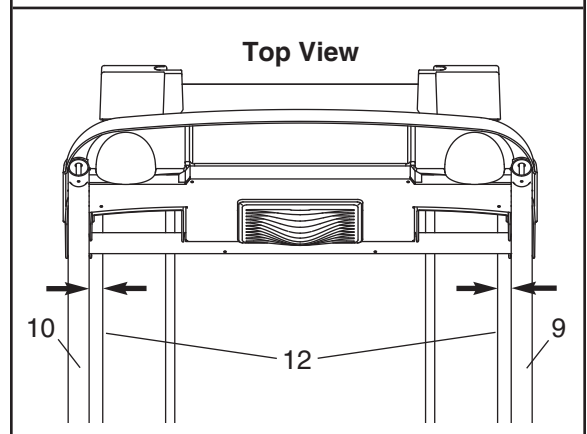
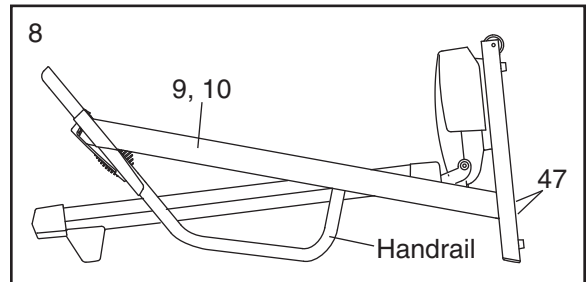

- Remove the knob from the pin. Make sure that the collar and the spring are on the pin as shown. Insert the pin into the Latch Housing (77), and tighten the knob back onto the pin.

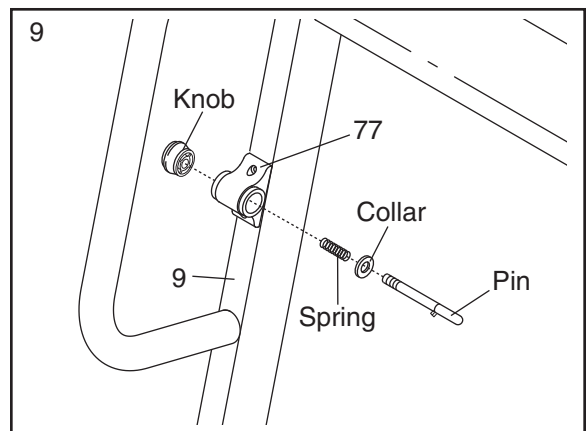

- Make sure that all parts are properly tightened before you use the treadmill.** Note: Extra hardware may be included. Keep the included allen wrench in a secure place. The allen wrench is used to adjust the walking belt (see page 24). To protect the floor or carpet, place a mat under the treadmill.

OPERATION AND ADJUSTMENT

THE PRE-LUBRICATED WALKING BELT

Your treadmill features a walking belt coated with high-performance lubricant. **IMPORTANT: Never apply silicone spray or other substances to the walking belt or the walking platform. Such substances will deteriorate the walking belt and cause excessive wear.**

HOW TO PLUG IN THE POWER CORD

! DANGER: Improper connection of the equipment-grounding conductor can result in an increased risk of electric shock. Check with a qualified electrician or serviceman if you are in doubt as to whether the product is properly grounded. Do not modify the plug provided with the product—if it will not fit the outlet, have a proper outlet installed by a qualified electrician.

Your treadmill, like any other type of sophisticated electronic equipment, can be seriously damaged by sudden voltage changes in your home's power. Voltage surges, spikes, and noise interference can result from weather conditions or from other appliances being turned on or off. **To decrease the possibility of your treadmill being damaged, always use a surge suppressor with your treadmill (see drawing 1 at the right).** To purchase a surge suppressor, see your local PROFORM dealer or call 1-888-533-1333 and order part number 146148, or see your local electronics store.

Use only a single-outlet surge suppressor that is UL 1449 listed as a transient voltage surge suppressor (TVSS). The surge suppressor must have a UL suppressed voltage rating of 400 volts or less and a minimum surge dissipation of 450 joules. The surge suppressor must be electrically rated for 120 volts AC and 15 amps. There must be a monitoring light on the surge suppressor to indicate whether it is functioning properly. Failure to use a properly functioning surge suppressor could result in damage to the control system of the treadmill. If the control system is damaged, the walking belt may change speed, accelerate or stop unexpectedly, which may result in a fall and serious injury.

This product must be grounded. If it should malfunction or break down, grounding provides a path of least resistance for electric current to reduce the risk of elec-

tric shock. This product is equipped with a cord having an equipment-grounding conductor and a grounding plug. **Plug the power cord into a surge suppressor, and plug the surge suppressor into an appropriate outlet that is properly installed and grounded in accordance with all local codes and ordinances. Important: The treadmill is not compatible with GFCI-equipped outlets.**

This product is for use on a nominal 120-volt circuit, and has a grounding plug that looks like the plug illustrated in drawing 1 below. A temporary adapter that looks like the adapter illustrated in drawing 2 may be used to connect the surge suppressor to a 2-pole receptacle as shown in drawing 2 if a properly grounded outlet is not available.

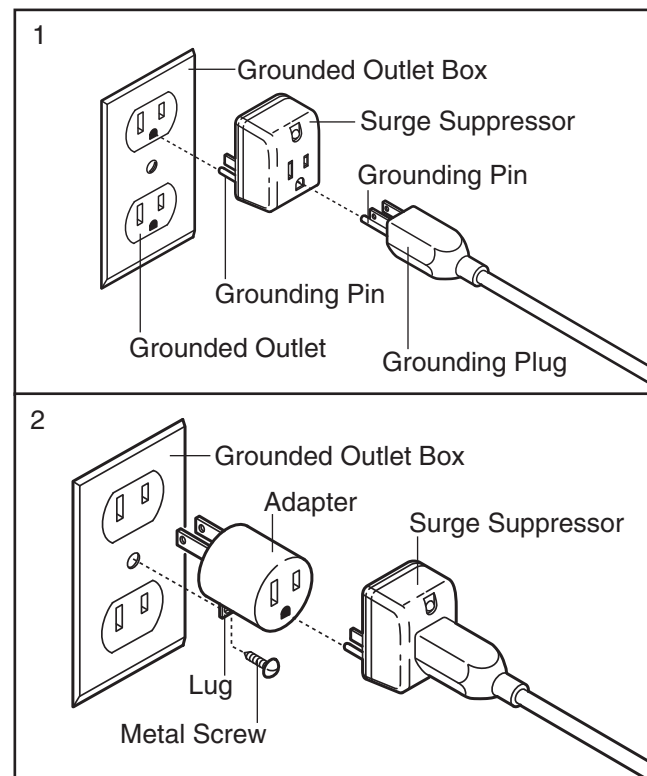

The temporary adapter should be used only until a properly grounded outlet (drawing 1) can be installed by a qualified electrician.

The green-colored rigid ear, lug, or the like extending from the adapter must be connected to a permanent ground such as a properly grounded outlet box cover. Whenever the adapter is used it must be held in place by a metal screw. **Some 2-pole receptacle outlet box covers are not grounded. Contact a qualified electrician to determine if the outlet box cover is grounded before using an adapter.**

CONSOLE DIAGRAM

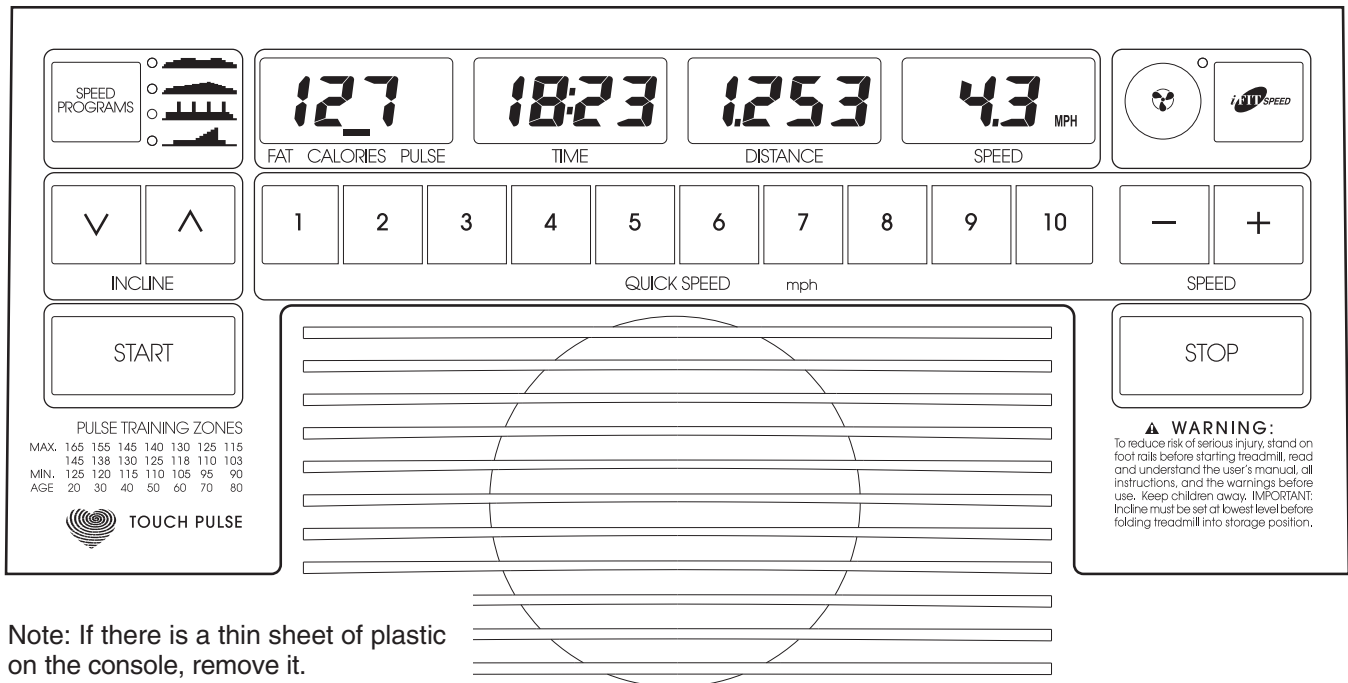

CAUTION: Before operating the console, read the following precautions.

- Do not stand on the walking belt while turning on the power.
- Always wear the clip (see the drawing near the top of page 12) while operating the treadmill.
- Adjust the speed in small increments to avoid sudden jumps in speed.
- To reduce the possibility of electric shock, keep the console dry. Avoid spilling liquids on the console and place only a sealed water bottle in the water bottle holder.

FEATURES OF THE CONSOLE

The console offers a selection of features designed to help you get the most from your exercise. When the manual mode of the console is selected, the speed and incline of the treadmill can be changed with the touch of a button. As you exercise, the console will display continuous exercise feedback. You can even measure your heart rate using the built-in pulse sensor.

Four speed programs are also offered. Each program automatically controls the speed of the treadmill as it guides you through an effective workout.

The console also features new iFIT.com interactive technology. Having iFIT.com technology is like having a personal trainer in your home. Using the included audio cable, you can connect the treadmill to your home stereo, portable stereo, computer, or VCR and play special iFIT.com CD and video programs (iFIT.com CDs and videocassettes are available separately). iFIT.com CD and video programs automatically control the speed of the treadmill as a personal trainer coaches you through every step of your workout. High-energy music provides added motivation. **To purchase iFIT.com CDs or videocassettes, call toll-free 1-888-533-1333.**

With the treadmill connected to your computer, you can also go to our Web site at www.iFIT.com and access programs directly from the internet. Additional options are soon to be available. **See www.iFIT.com for more information.**

To use the manual mode of the console, follow the steps beginning on page 12. **To use a speed program**, see page 14. **To use an iFIT.com CD or video program**, see page 18. **To use an iFIT.com program directly from our Web site**, see page 19.

HOW TO TURN ON THE POWER

- 1 Plug in the power cord (see page 10).
- 2 Stand on the foot rails of the treadmill.
- 3 Find the clip attached to the key, and slide the clip securely onto the waistband of your clothes. Next, insert the key into the console.

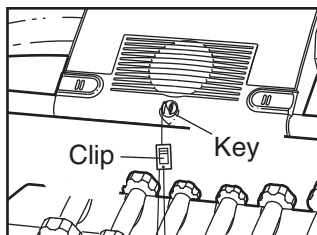

After a moment, the displays will light. **Test the clip by carefully taking a few steps backward until the key is pulled from the console. If the key is not pulled from the console, adjust the position of the clip.**

HOW TO USE THE MANUAL MODE

- 1 **Insert the key into the console.**
See HOW TO TURN ON THE POWER above.
- 2 **Select the manual mode.**
When the key is inserted, the manual mode will be selected. If a program has been selected, press the iFIT Speed button once or twice, until the indicator beside the button is **not** lit.
- 3 **Start the walking belt.**
To start the walking belt, press the Start button, the Speed + button, or one of the ten Quick Speed buttons.

If the Start button or the Speed + button is pressed, the walking belt will begin to move at 1 mph. As you exercise, change the speed of the walking belt as desired by pressing the Speed + and – buttons. Each time a button is pressed, the speed setting will change by 0.1 mph; if a button

is held down, the speed setting will change in increments of 0.5 mph.

If one of the Quick Speed buttons is pressed, the walking belt will gradually increase in speed until it reaches the selected speed setting. **Note: The console can display speed and distance in either miles or kilometers (see SPEED DISPLAY on page 13). For simplicity, all instructions in this section refer to miles.**

To stop the walking belt, press the Stop button. The Time display will begin to flash. To restart the walking belt, press the Start button or the Speed + button.

Note: The first time you use the treadmill, periodically inspect the alignment of the walking belt, and align it if necessary (see page 24).

- 4 **Change the incline of the treadmill as desired.**
To change the incline of the treadmill, press either of the Incline buttons until the desired incline level is reached.
- 5 **Follow your progress with the displays.**

Fat Calories/Calories/Pulse display—This display shows the approximate number of *fat calories* and *calories* you have burned (see FAT BURNING on page 25). The display will change from one number to the next every few seconds, as shown by the indicators in the display. The display will also show your heart rate when you use the pulse sensor (see step 6 on page 13).



Time display—When the manual mode or the iFIT.com mode is selected, this display will show the elapsed time. When a speed program is selected, the display will show the time remaining in the program.



Distance display—This display shows the distance that you have walked or run.

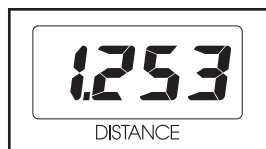

Speed display—This display shows the speed of the walking belt.



Note: The console can show speed and distance in either miles or kilometers. The letters "MPH" or "KPH" will appear in the Speed display to show which unit of measurement is selected. To change the unit of measurement, first hold down the Stop button, insert the key into the console, and continue to hold the Stop button for a few seconds. An "E" (for English) or an "M" (for metric) will appear in the display. Press the Speed + button to change the unit of measurement. When the desired unit of measurement is selected, remove the key and then reinsert it.

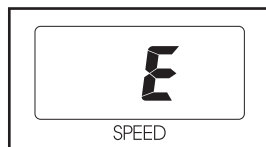

To reset the displays, press the Stop button, remove the key, and then reinsert the key.

6 Measure your heart rate, if desired.

To measure your heart rate, **stand on the foot rails** and place your thumbs on the pulse sensors. **Do not press too hard, or the circulation in your thumbs will be restricted and your pulse will not be detected.**

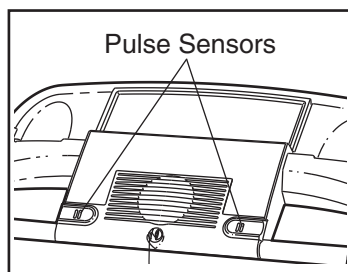

When your pulse is detected, the heart-shaped indicator in the Fat Calories/Calories/Pulse display will flash each time your heart beats, and your heart rate will be shown. **For the most accurate heart rate reading, hold your thumbs on the pulse sensors for about 15 seconds.**



If the displayed heart rate appears to be too high or too low, or if your heart rate is not displayed, lift your thumbs off the pulse sensors for a few seconds. Then, place your thumbs on the pulse sensors as described above. Remember to stand still while measuring your heart rate.

7 Turn on the fan if desired.

To turn on the fan at low speed, press the fan button. To turn on the fan at high speed, press the button a second time. To turn off the fan, press the button a third time. Note: Any time that the walking belt is stopped for a few minutes, the fan will automatically turn off.

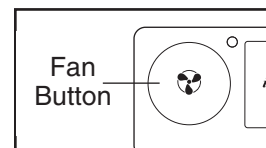

8 When you are finished exercising, remove the key.

Step onto the foot rails and press the Stop button. **Adjust the incline of the treadmill to the lowest setting.** Next, remove the key from the console and put it in a secure place.

HOW TO USE A SPEED PROGRAM

1 Insert the key fully into the console.

See HOW TO TURN ON THE POWER on page 12.

2 Select a speed program.

When the key is inserted, the manual mode will be selected. To select a speed program, press the Speed Programs button repeatedly until one of the four speed program indicators lights. When a speed program is selected, the Time display will show how long the program will last, and the Speed display will flash the maximum speed setting for the program for a few seconds.

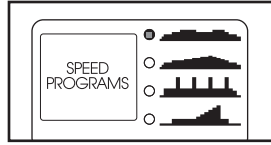

3 Press the Start button or the Speed + button to start the program.

A moment after the button is pressed, the treadmill will automatically adjust to the first speed setting for the program. Hold the handrails and begin walking.

Each program is divided into several time periods of different lengths. One speed setting is programmed for each period. Note: The same speed setting may be programmed for two or more consecutive periods.

When only a few seconds remain in the first period of the program, the Speed display will flash and a series of tones will sound. The treadmill will then automatically adjust to the speed setting for the second period. Note: When the same speed setting is programmed for consecutive periods, the Speed display will not flash during the last three seconds of the current period.

To change the incline of the treadmill during the program, press the Incline buttons until the desired incline level is reached.

The program will continue until no time remains in the Time display. The walking belt will then slow to a stop.

Note: If the speed setting for the current period is too high or too low, you can manually override the setting by pressing the Speed buttons. **Important: When the current period of the program ends, the treadmill will automatically adjust to the speed setting for the next period.**

To stop the program temporarily, press the Stop button. The Time display will begin to flash. To restart the program, press the Start button or the Speed + button. To end the program, press the Stop button, remove the key, and then reinsert the key.

4 Follow your progress with the displays.

See step 5 on page 12.

5 Measure your heart rate, if desired.

See step 6 on page 13.

6 Turn on the fan if desired.

See step 7 on page 13.

7 When the program is completed, remove the key from the console.

When the program has ended, **adjust the incline of the treadmill to the lowest setting.** Next, remove the key from the console and put it in a safe place.

HOW TO CONNECT THE TREADMILL TO YOUR CD PLAYER, VCR, OR COMPUTER

To use **iFIT.com CDs**, the treadmill must be connected to your portable CD player, portable stereo, home stereo, or computer with CD player. See pages 15 and 16 for connecting instructions. To use **iFIT.com video-cassettes**, the treadmill must be connected to your VCR. See page 17 for connecting instructions. To use **iFIT.com programs directly from our internet site**, the treadmill must be connected to your home computer. See page 16 for connecting instructions.

HOW TO CONNECT YOUR PORTABLE CD PLAYER

Note: If your CD player has separate **LINE OUT** and **PHONES** jacks, see instruction A below. If your CD player has only one jack, see instruction B.

- A. Plug one end of the audio cable into the jack on the front of the treadmill near the power cord. Plug the other end of the cable into the **LINE OUT** jack on your CD player. Plug your headphones into the **PHONES** jack.

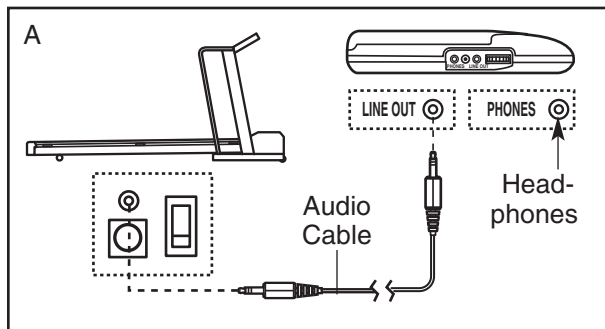

- B. Plug one end of the audio cable into the jack on the front of the treadmill near the power cord. Plug the other end of the cable into a 3.5mm Y-adaptor (available at electronics stores). Plug the Y-adaptor into the **PHONES** jack on your CD player. Plug your headphones into the other side of the Y-adaptor.

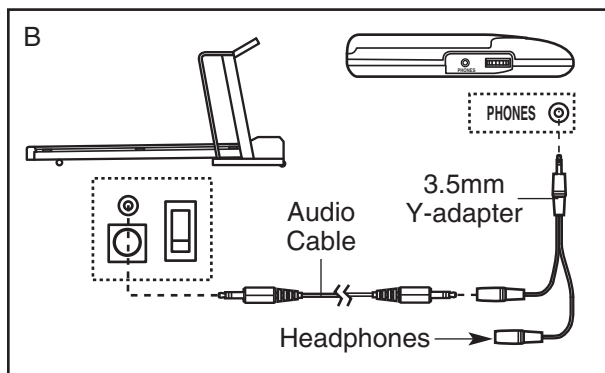

HOW TO CONNECT YOUR PORTABLE STEREO

Note: If your stereo has an **RCA-type AUDIO OUT** jack, see instruction A below. If your stereo has a **3.5mm LINE OUT** jack, see instruction B. If your stereo has only a **PHONES** jack, see instruction C.

- A. Plug one end of the audio cable into the jack on the front of the treadmill near the power cord. Plug the other end of the cable into the included adaptor. Plug the adaptor into an **AUDIO OUT** jack on your stereo.

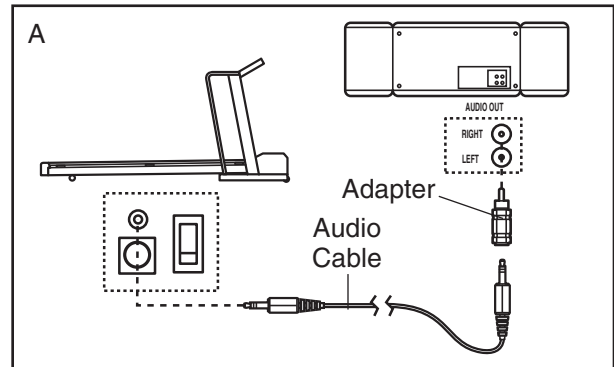

- B. Plug one end of the audio cable into the jack on the front of the treadmill near the power cord. Plug the other end of the cable into the **LINE OUT** jack on your stereo.

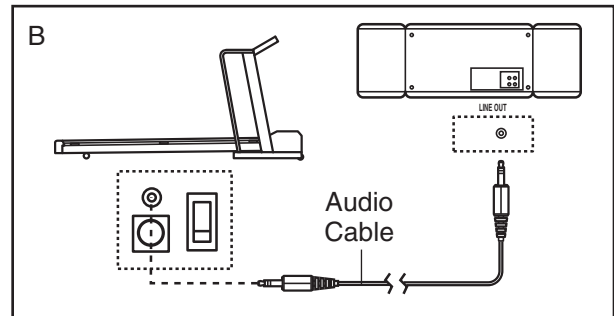

- C. Plug one end of the audio cable into the jack on the front of the treadmill near the power cord. Plug the other end of the cable into a 3.5mm Y-adaptor (available at electronics stores). Plug the Y-adaptor into the **PHONES** jack on your stereo. Plug your headphones into the other side of the Y-adaptor.

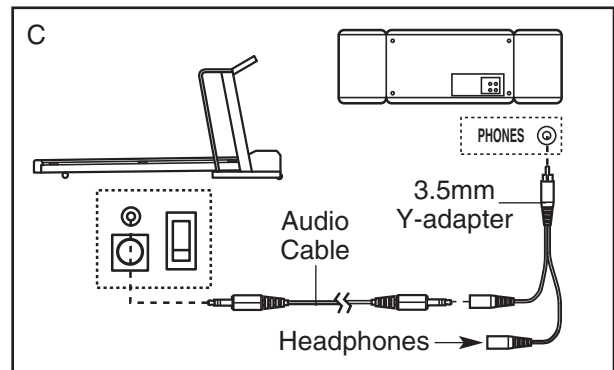

HOW TO CONNECT YOUR HOME STEREO

Note: If your stereo has an unused **LINE OUT** jack, see instruction **A** below. If the **LINE OUT** jack is being used, see instruction **B**.

- A. Plug one end of the audio cable into the jack on the front of the treadmill near the power cord. Plug the other end of the cable into the included adapter. Plug the adapter into the **LINE OUT** jack on your stereo.

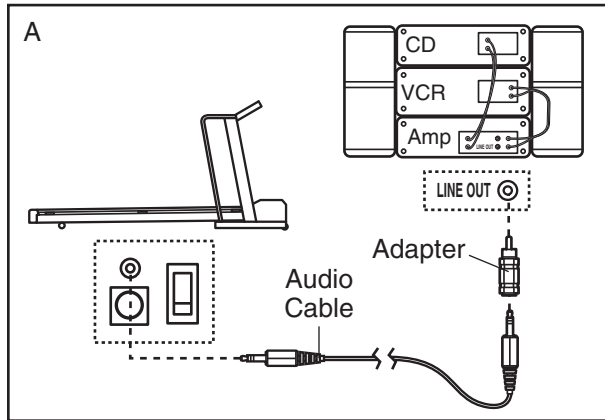

- B. Plug one end of the audio cable into the jack on the front of the treadmill near the power cord. Plug the other end of the cable into the included adapter. Plug the adapter into an **RCA Y-adapter** (available at electronics stores). Next, remove the wire that is currently plugged into the **LINE OUT** jack on your stereo and plug the wire into the unused side of the **Y-adapter**. Plug the **Y-adapter** into the **LINE OUT** jack on your stereo.

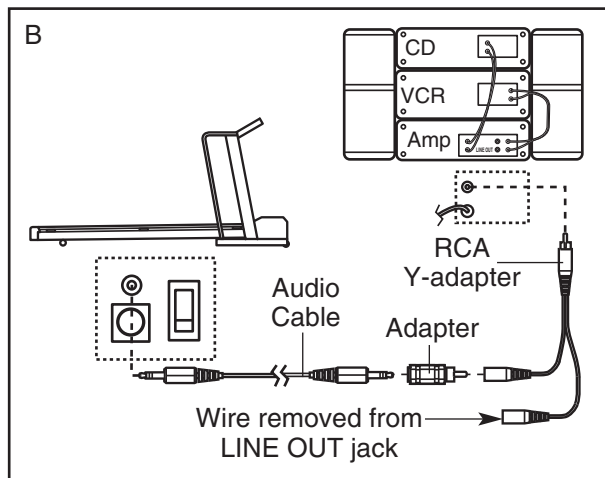

HOW TO CONNECT YOUR COMPUTER

Note: If your computer has a **3.5mm LINE OUT** jack, see instruction **A**. If your computer has only a **PHONES** jack, see instruction **B**.

- A. Plug one end of the audio cable into the jack on the front of the treadmill near the power cord. Plug the other end of the cable into the **LINE OUT** jack on your computer.

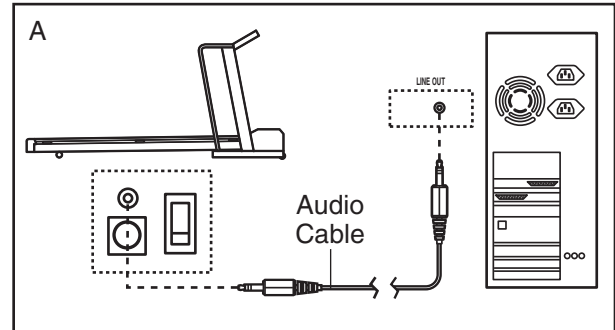

- B. Plug one end of the audio cable into the jack on the front of the treadmill near the power cord. Plug the other end of the cable into a **3.5mm Y-adapter** (available at electronics stores). Plug the **Y-adapter** into the **PHONES** jack on your computer. Plug your headphones or speakers into the other side of the **Y-adapter**.

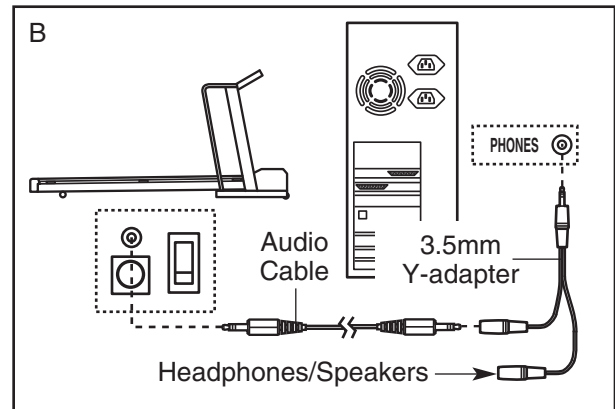

HOW TO CONNECT YOUR VCR

Note: If your VCR has an unused AUDIO OUT jack, see instruction A below. If the AUDIO OUT jack is being used, see instruction B. If you have a TV with a built-in VCR, see instruction B. If your VCR is connected to your home stereo, see HOW TO CONNECT YOUR HOME STEREO on page 16.

- A. Plug one end of the audio cable into the jack on the front of the treadmill near the power cord. Plug the other end of the cable into the included adapter. Plug the adapter into the AUDIO OUT jack on your VCR.

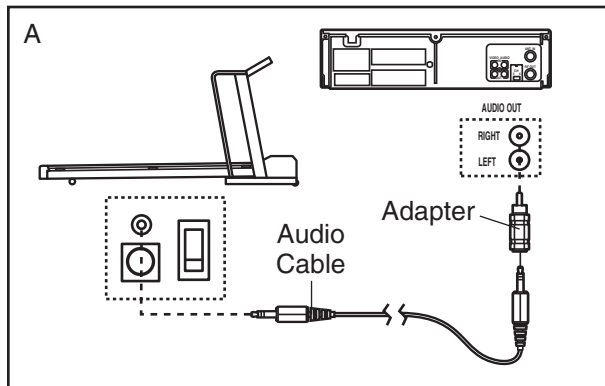

- B. Plug one end of the audio cable into the jack on the front of the treadmill near the power cord. Plug the other end of the cable into the included adapter. Plug the adapter into an RCA Y-adapter (available at electronics stores). Next, remove the wire that is currently plugged into the AUDIO OUT jack on your VCR and plug the wire into the unused side of the Y-adapter. Plug the Y-adapter into the AUDIO OUT jack on your VCR.

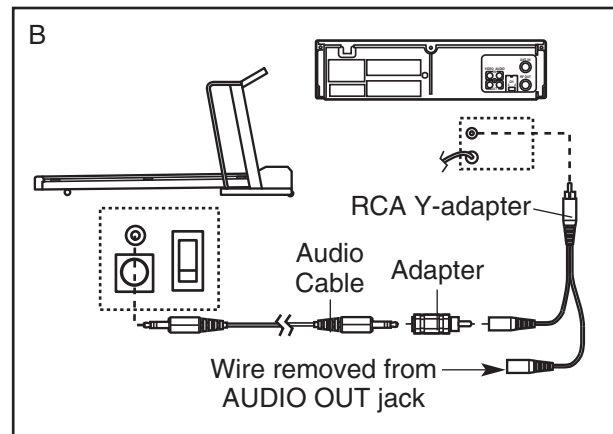

HOW TO USE iFIT.COM CD AND VIDEO PROGRAMS

To use iFIT.com CDs or videocassettes, the treadmill must be connected to your portable CD player, portable stereo, home stereo, computer with CD player, or VCR. See HOW TO CONNECT THE TREADMILL TO YOUR CD PLAYER, VCR, OR COMPUTER on pages 15 to 17. **Note: iFIT.com CD and video programs will control only the speed of your treadmill.**

To purchase iFIT.com CDs or videocassettes, call toll-free 1-888-533-1333.

Follow the steps below to use an iFIT.com CD or video program.

1 Insert the key into the console.

See HOW TO TURN ON THE POWER on page 12.

2 Select the iFIT.com mode.

When the key is inserted, the manual mode will be selected. To use iFIT.com CDs or videocassettes, press the iFIT Speed button. The indicator beside the button will light.

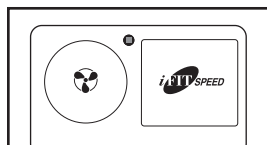

3 Insert the iFIT.com CD or videocassette.

If you are using an iFIT.com CD, insert the CD into your CD player. If you are using an iFIT.com videocassette, insert the videocassette into your VCR.

4 Press the PLAY button on your CD player or VCR.

A moment after the button is pressed, your personal trainer will begin guiding you through your workout. Simply follow your personal trainer's instructions. **Note:** If the Time display is flashing, press the Start button or the Speed + button on the console. The treadmill will not respond to a CD or video program when the Time display is flashing.

During the CD or video program, an electronic "chirping" sound will alert you when the speed of the treadmill is about to change. **CAUTION: Always listen for the "chirp" and be prepared for speed changes. In some instances, the speed may change before the personal trainer describes the change.**

If the speed setting is too high or too low, you can manually override the setting at any time by pressing the Speed buttons on the console. However, **when the next "chirp" is heard, the speed will change to the next setting of the CD or video program.**

To stop the walking belt at any time, press the Stop button on the console. The Time display will begin to flash. To restart the program, press the Start button or the Speed + button. After a moment, the walking belt will begin to move. **When the next "chirp" is heard, the speed will change to the next setting of the CD or video program.**

When the CD or video program is completed, the walking belt will stop and the Time display will begin to flash. **Note:** To use another CD or video program, press the Stop button or remove the key and go to step 1.

Note: If the speed of the treadmill does not change when a "chirp" is heard:

- Make sure that the iFIT.com indicator is lit and that the Time display is not flashing. If the Time display is flashing, press the Start button or the Speed + button on the console.
- Adjust the volume of your CD player or VCR. If the volume is too high or too low, the console may not detect the program signals.
- Make sure that the audio cable is properly connected, that it is fully plugged in, and that it is not wrapped around a power cord.

5 Follow your progress with the displays.

See step 5 on page 12.

6 Measure your heart rate, if desired.

See step 6 on page 13.

7 Turn on the fan if desired.

See step 7 on page 13.

8 When the program is completed, remove the key.

See step 7 on page 14.

CAUTION: Always remove iFIT.com CDs and videocassettes from your CD player or VCR when you are finished using them.

HOW TO USE PROGRAMS DIRECTLY FROM OUR WEB SITE

Our Web site at www.iFIT.com allows you to access programs directly from the internet. See www.iFIT.com for details. **Note: Programs will control only the speed of your treadmill.**

To use programs from our Web site, the treadmill must be connected to your home computer. See HOW TO CONNECT YOUR COMPUTER on page 16. In addition, you must have an internet connection and an internet service provider. A list of specific system requirements is found on our Web site.

Follow the steps below to use a program from our Web site.

1 Insert the key into the console.

See HOW TO TURN ON THE POWER on page 12.

2 Select the iFIT.com mode.

When the key is inserted, the manual mode will be selected. To use a program from our Web site, press the iFIT Speed button. The indicator beside the button will light.

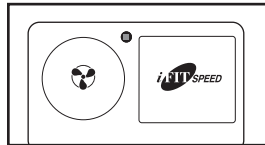

3 Go to your computer and start an internet connection.

4 Start your web browser, if necessary, and go to our Web site at www.iFIT.com.

5 Follow the desired links on our Web site to select a program.

Read and follow the on-line instructions for using a program.

6 Follow the on-line instructions to start the program.

When you start the program, an on-screen countdown will begin.

7 Return to the treadmill and stand on the foot rails. Find the clip attached to the key and slide the clip onto the waistband of your clothes.

When the on-screen countdown ends, the program

will begin and the walking belt will begin to move. Hold the handrails, step onto the walking belt, and begin walking. During the program, an electronic “chirping” sound will alert you when the speed of the treadmill is about to change. **CAUTION: Always listen for the “chirp” and be prepared for speed changes.**

If the speed setting is too high or too low, you can manually override the setting at any time by pressing the Speed buttons on the console. **However, when the next “chirp” is heard, the speed will change to the next setting for the program.**

To stop the walking belt at any time, press the Stop button on the console. The Time display will begin to flash. To restart the program, press the Start button or the Speed + button. After a moment, the walking belt will begin to move. **When the next “chirp” is heard, the speed will change to the next setting for the program.**

When the program is completed, the walking belt will stop and the Time display will begin to flash. Note: To use another program, press the Stop button and go to step 5.

Note: If the speed of the treadmill does not change when a “chirp” is heard, make sure that the iFIT.com indicator is lit and that the Time display is not flashing. In addition, make sure that the audio cable is properly connected, that it is fully plugged in, and that it is not wrapped around a power cord.

8 Follow your progress with the displays.

See step 5 on page 12.

9 Measure your heart rate, if desired.

See step 6 on page 13.

10 Turn on the fan if desired.

See step 7 on page 13.

11 When the program is completed, remove the key.

See step 7 on page 14.

THE INFORMATION MODE

The console features an information mode that keeps track of the total number of hours that the treadmill has been operated and the total number of miles that the walking belt has moved. The information mode also allows you to switch the console from miles per hour to kilometers per hour.

To select the information mode, hold down the Stop button, insert the key into the console, and continue to hold the Stop button for a few seconds. When the information mode is selected, the following information will be shown:

The Time display will show the total number of hours that the treadmill has been used.



The Distance display will show the total number of miles (or kilometers) that the walking belt has moved.



An "E" (for English) or an "M" (for metric) will appear in the Speed display. Press the Speed + button to change the unit of measurement.

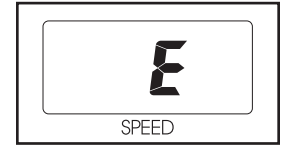

To exit the information mode, remove the key from the console.

HOW TO FOLD AND MOVE THE TREADMILL

HOW TO FOLD THE TREADMILL FOR STORAGE

Before folding the treadmill, adjust the incline to the lowest position. If this is not done, the treadmill may be permanently damaged. Next, unplug the power cord. **CAUTION: You must be able to safely lift 45 pounds (20 kg) to raise, lower, or move the treadmill.**

1. Hold the treadmill with your hands in the locations shown at the right. **CAUTION: To decrease the possibility of injury, bend your legs and keep your back straight. As you raise the treadmill, make sure to lift with your legs rather than your back.** Raise the treadmill about halfway to the vertical position.



2. Move your right hand to the position shown and hold the treadmill firmly. Using your left hand, pull the latch knob to the left and hold it. Raise the treadmill until the hole in the frame is aligned with the pin on the latch knob. Slowly release the latch knob. **Make sure that the frame is held by the pin.**

To protect the floor or carpet from damage, place a mat under the treadmill. Keep the treadmill out of direct sunlight. Do not leave the treadmill in the storage position in temperatures above 85° Fahrenheit.

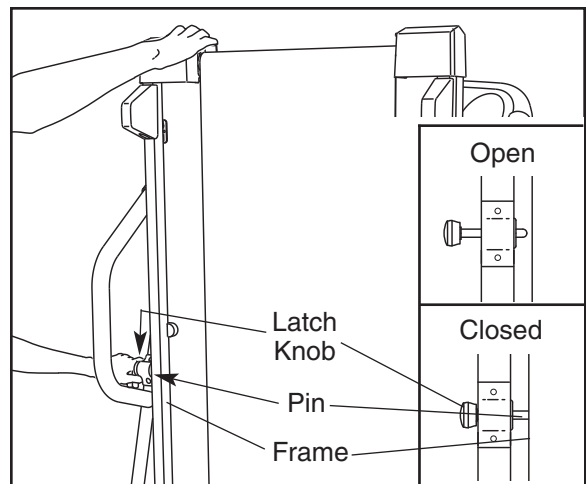

HOW TO MOVE THE TREADMILL

Before moving the treadmill, convert the treadmill to the storage position as described above. **Make sure that the frame is securely held by the pin on the latch knob.**

1. Hold the upright as shown and place one foot against a wheel.
2. Tilt the treadmill back until it rolls freely on the wheels. Carefully move the treadmill to the desired location. **Never move the treadmill without tipping it back. To reduce the risk of injury, use extreme caution while moving the treadmill. Do not attempt to move the treadmill over an uneven surface.**
3. Place one foot on a wheel, and carefully lower the treadmill until it is resting in the storage position.



HOW TO LOWER THE TREADMILL FOR USE

1. Hold the upper end of the treadmill with your right hand as shown. Using your left hand, pull the latch knob to the left and hold it. Pivot the treadmill down until the frame is past the pin. Slowly release the latch knob.

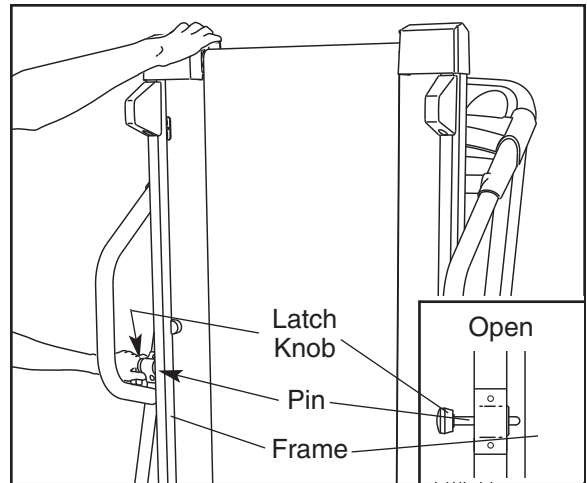

2. Hold the treadmill firmly with both hands, and lower the treadmill to the floor. **Do not drop the treadmill frame to the floor. CAUTION: To decrease the possibility of injury, bend your legs and keep your back straight.**

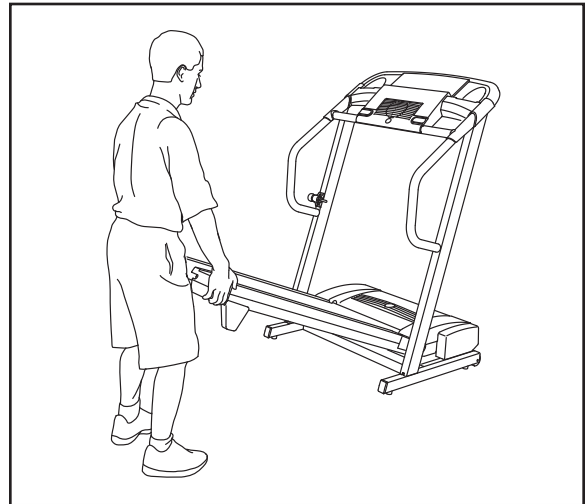

TROUBLESHOOTING

Most treadmill problems can be solved by following the steps below. Find the symptom that applies, and follow the steps listed. If further assistance is needed, please call our Customer Service Department toll-free at 1-888-533-1333, Monday through Friday, 6 a.m. until 6 p.m. Mountain Time (excluding holidays).

PROBLEM: The power does not turn on

SOLUTION: a. Make sure that the power cord is plugged into a surge suppressor, and that the surge suppressor is plugged into a properly grounded outlet (see page 10). Use only a single-outlet surge suppressor that meets all of the specifications described on page 10. Important: The treadmill is not compatible with GFCI-equipped outlets.

b. After the power cord has been plugged in, make sure that the key is fully inserted into the console.

c. Check the reset/off circuit breaker located on the treadmill near the power cord. If the switch protrudes as shown, the circuit breaker has tripped. To reset the circuit breaker, wait for five minutes and then press the switch back in.

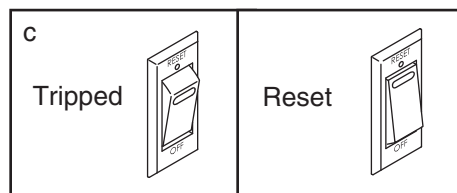

PROBLEM: The power turns off during use

SOLUTION: a. Check the reset/off circuit breaker located on the treadmill frame near the power cord (see c. above). If the circuit breaker has tripped, wait for five minutes and then press the switch back in.

b. Make sure that the power cord is plugged in. If the power cord is plugged in, unplug it, wait for five minutes, and then plug it back in.

c. Remove the key from the console. Reinsert the key into the console.

d. If the treadmill still will not run, please call our Customer Service Department, toll-free.

PROBLEM: The speed display on the console does not function properly

SOLUTION: a. Remove the key and **UNPLUG THE POWER CORD**. Remove the Hood Screws (58) and the Hood (94) from the treadmill.

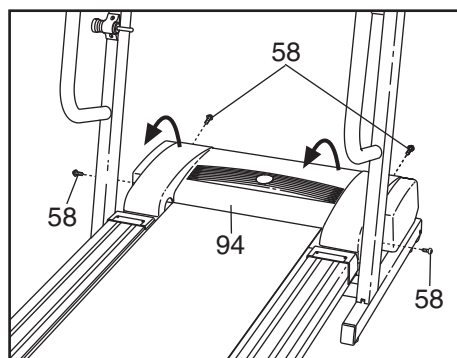

Locate the Reed Switch (21) and the Magnet (43) on the left side of the Pulley (42). Turn the Pulley until the Magnet is aligned with the Reed Switch. **Make sure that the gap between the Magnet and the Reed Switch is about 1/8"**. If necessary, loosen the Screw (62), move the Reed Switch slightly, and then retighten the Screw. Reattach the hood, and run the treadmill for a few minutes to check for a correct speed reading.

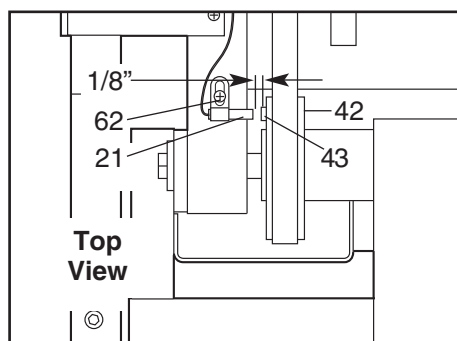

PROBLEM: The walking belt slows when walked on

SOLUTION: a. Use only a single-outlet surge suppressor that meets all of the specifications described on page 10.

b. If the walking belt is overtightened, treadmill performance may decrease and the walking belt may become damaged. Remove the key and **UNPLUG THE POWER CORD**. Using the allen wrench, turn both rear roller adjustment bolts counterclockwise 1/4 of a turn. When the walking belt is properly tightened, you should be able to lift each side of the walking belt 3 to 4 inches off the walking platform. Be careful to keep the walking belt centered. Plug in the power cord, insert the key, and run the treadmill for a few minutes. Repeat until the walking belt is properly tightened.

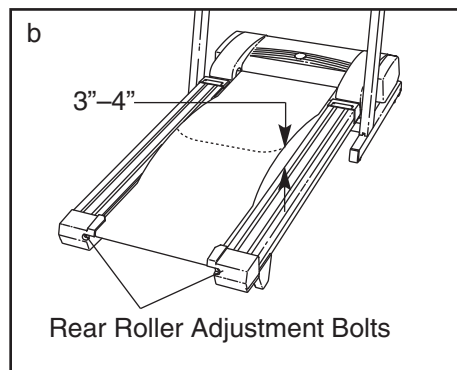

c. If the walking belt still slows when walked on, please call our Customer Service Department, toll-free.

PROBLEM: The walking belt is off-center or slips when walked on

SOLUTION: a. If the walking belt is off-center, first remove the key and **UNPLUG THE POWER CORD**. If the walking belt has shifted to the left, use the allen wrench to turn the left rear roller bolt clockwise 1/2 of a turn; if the walking belt has shifted to the right, turn the bolt counterclockwise 1/2 of a turn. Be careful not to overtighten the walking belt. Plug in the power cord, insert the key, and run the treadmill for a few minutes. Repeat until the walking belt is centered.

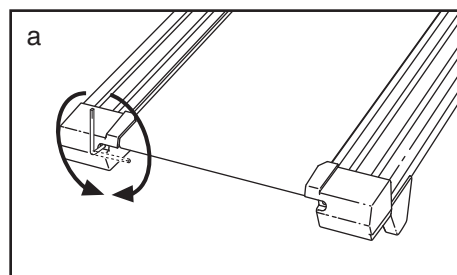

b. If the walking belt slips when walked on, first remove the key and **UNPLUG THE POWER CORD**. Using the allen wrench, turn both rear roller bolts clockwise, 1/4 of a turn. When the walking belt is correctly tightened, you should be able to lift each side of the walking belt 3 to 4 inches off the walking platform. Be careful to keep the walking belt centered. Plug in the power cord, insert the key, and carefully walk on the treadmill for a few minutes. Repeat until the walking belt is properly tightened.

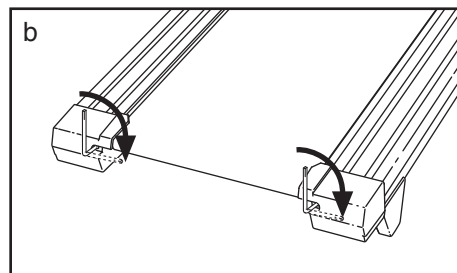

CONDITIONING GUIDELINES

⚠️ WARNING: Before beginning this or any exercise program, consult your physician. This is especially important for individuals over the age of 35 or individuals with pre-existing health problems.

The pulse sensor is not a medical device. Various factors, including the user's movement, may affect the accuracy of heart rate readings. The pulse sensor is intended only as an exercise aid in determining heart rate trends in general.

The following guidelines will help you to plan your exercise program. For more detailed exercise information, obtain a reputable book or consult your physician.

EXERCISE INTENSITY

Whether your goal is to burn fat or to strengthen your cardiovascular system, the key to achieving the desired results is to exercise with the proper intensity. The proper intensity level can be found by using your heart rate as a guide. The chart below shows recommended heart rates for fat burning and aerobic exercise.

HEART RATE TRAINING ZONES							
AEROBIC	165	155	145	140	130	125	115
MAX FAT BURN	145	138	130	125	118	110	103
FAT BURN	125	120	115	110	105	95	90
Age	20	30	40	50	60	70	80

To find the proper heart rate for you, first find your age near the bottom of the chart (ages are rounded off to the nearest ten years). Next, find the three numbers above your age. The three numbers define your “training zone.” The lower two numbers are recommended heart rates for fat burning; the highest number is the recommended heart rate for aerobic exercise.

To measure your heart rate during exercise, use the handgrip pulse sensor.

Fat Burning

To burn fat effectively, you must exercise at a relatively low intensity level for a sustained period of time. During the first few minutes of exercise, your body uses easily accessible *carbohydrate calories* for en-

ergy. Only after the first few minutes does your body begin to use stored *fat calories* for energy. If your goal is to burn fat, adjust the speed or incline of the treadmill until your heart rate is near the lowest number in your training zone.

For maximum fat burning, adjust the speed or incline of the treadmill until your heart rate is near the middle number in your training zone.

Aerobic Exercise

If your goal is to strengthen your cardiovascular system, your exercise must be “aerobic.” Aerobic exercise is activity that requires large amounts of oxygen for prolonged periods of time. This increases the demand on the heart to pump blood to the muscles, and on the lungs to oxygenate the blood. For aerobic exercise, adjust the speed or incline of the treadmill until your heart rate is near the highest number in your training zone.

WORKOUT GUIDELINES

Each workout should include the following three parts:

A Warm-up—Start each workout with 5 to 10 minutes of stretching and light exercise. A proper warm-up increases your body temperature, heart rate and circulation in preparation for exercise.

Training Zone Exercise—After warming up, increase the intensity of your exercise until your pulse is in your training zone for 20 to 60 minutes. (During the first few weeks of your exercise program, do not keep your pulse in your training zone for longer than 20 minutes.) Breathe regularly and deeply as you exercise—never hold your breath.

A Cool-down—Finish each workout with 5 to 10 minutes of stretching to cool down. This will increase the flexibility of your muscles and will help prevent post-exercise problems.

EXERCISE FREQUENCY

To maintain or improve your condition, complete three workouts each week, with at least one day of rest between workouts. After a few months, you may complete up to five workouts each week if desired. The key to success is to make exercise a regular and enjoyable part of your everyday life.

SUGGESTED STRETCHES

The correct form for several basic stretches is shown at the right. Move slowly as you stretch—never bounce.

1. Toe Touch Stretch

Stand with your knees bent slightly and slowly bend forward from your hips. Allow your back and shoulders to relax as you reach down toward your toes as far as possible. Hold for 15 counts, then relax. Repeat 3 times. Stretches: Hamstrings, back of knees, and back.

2. Hamstring Stretch

Sit with one leg extended. Bring the sole of the opposite foot toward you and rest it against the inner thigh of your extended leg. Reach toward your toes as far as possible. Hold for 15 counts, then relax. Repeat 3 times for each leg. Stretches: Hamstrings, lower back, and groin.

3. Calf/Achilles Stretch

With one leg in front of the other, reach forward and place your hands against a wall. Keep your back leg straight and your back foot flat on the floor. Bend your front leg, lean forward and move your hips toward the wall. Hold for 15 counts, then relax. Repeat 3 times for each leg. To cause further stretching of the achilles tendons, bend your back leg as well. Stretches: Calves, achilles tendons, and ankles.

4. Quadriceps Stretch

With one hand against a wall for balance, reach back and grasp one foot with your other hand. Bring your heel as close to your buttocks as possible. Hold for 15 counts, then relax. Repeat 3 times for both legs. Stretches: Quadriceps and hip muscles.

5. Inner Thigh Stretch

Sit with the soles of your feet together and your knees outward. Pull your feet toward your groin area as far as possible. Hold for 15 counts, then relax. Repeat 3 times. Stretches: Quadriceps and hip muscles.

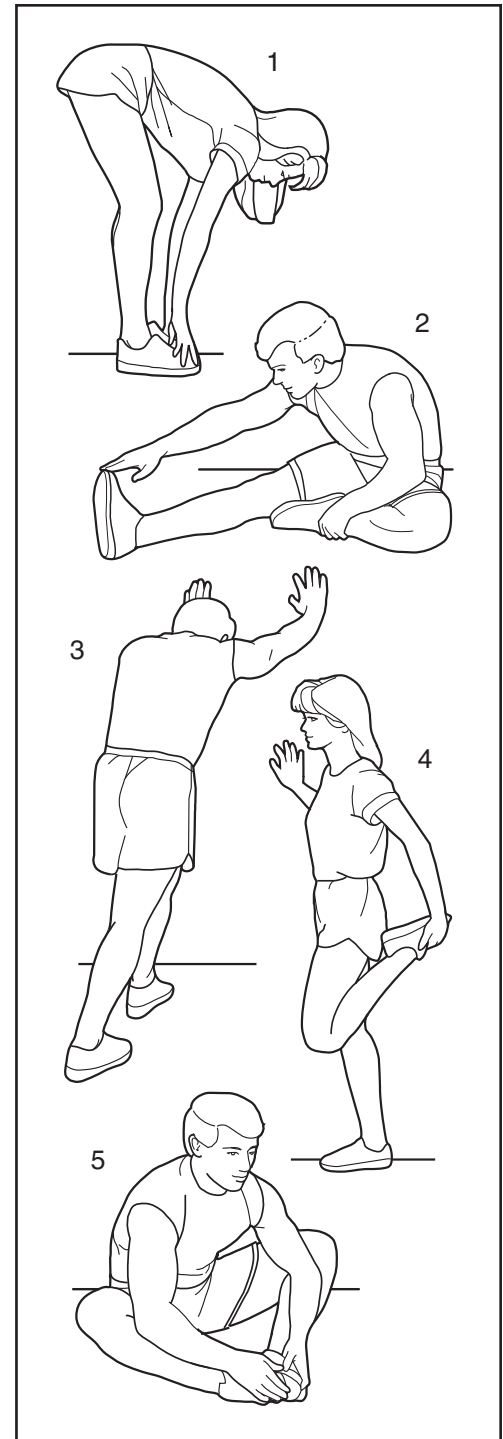

NOTES

PART LIST—Model No. DTL44950

R1104A

To locate the parts listed below, see the EXPLODED DRAWING on pages 29 to 31.

Key No.	Qty.	Description	Key No.	Qty.	Description	Key No.	Qty.	Description
1	1	Motor Belt	44	4	Platform Screw	88	1	Console Crossbar
2	1	Pulley/Flywheel/Fan	45	2	Isolator	89	1	Static Decal
3	4	Motor Nut	46	2	Center Platform Screw	90	1	Key/Clip
4*	1	Motor/Pulley/ Flywheel/ Fan	47	4	2 3/4" Bolt	91	1	Incline Motor Belly Pan
			48	2	3-lb. Weight	92	2	Roller Adj. Washer
5	1	Incline Motor Bolt	49	2	Belt Guide	93	1	Book Holder
6	1	Controller Wire	50	1	Fan	94	1	Motor Hood
7	1	Incline Motor	51	1	Front Belly Pan	95	2	Front Wheel
8	1	Filter Wire	52	1	Small Nut	96	1	Incline Motor Shield
9	1	Left Upright	53	3	Cable Tie Clamp	97	4	Base Pad
10	1	Right Upright	54	4	Cable Tie	98	1	iFIT Wire
11	1	Console Plate	55	1	Walking Belt	99	1	Upright Grommet
12	1	Frame	56	4	2 1/2" Bolt	100	1	Allen Wrench
13	1	Fan Cover	57	1	Rear Roller	101	8	3/4" Tek Screw
14	2	Fan Screw	58	4	Hood Screw	102	2	Controller Screw
15	4	Incline Motor Nut	59	2	Rear Foot	103	1	Power Board Plate
16	4	Belt Guide Screw	60	1	iFIT Jack	104	4	Base Cap
17	1	Upright Wire Harness	61	1	Ground Wire	105	2	Incline Pivot Nut
18	2	Hood Bracket	62	20	Screw	106	2	2-lb. Weight
19	1	Front Hood Bracket	63	1	Left Rear Endcap	107	1	1/2" Silver Screw
20	2	Warning Decal	64	1	Right Rear Endcap	108	1	Audio Wire Nut
21	1	Reed Switch	65	2	Rear Roller Adj. Bolt	109	1	Audio Wire
22	1	Reed Switch Clip	66	1	Motor	110	2	1" Spacer
23	1	Left Handrail	67	1	Latch Decal	111	1	Hood Spacer
24	1	Controller	68	2	Foot Rail Cover	112	2	Bumper
25	1	Electronics Bracket	69	3	Small Star Washer	113	1	Edge Guard
26	1	Reset/Off Circuit Breaker	70	1	Incline Disk	114	2	1/2" Spacer
			71	1	Walking Platform	115	4	1" Tek Screw
27	1	Power Cord	72	5	8" Cable Tie	116	2	Belly Pan Interface
28	1	Power Cord Grommet	73	1	Incline Bolt	117	1	Photo Switch
29	8	Washer	74	1	Motor Tension Bolt	118	1	Small Bolt
30*	1	Latch Assembly	75	2	Right Foot Rail	119	2	U-Nut
31	1	Incline Frame	76	6	Belly Pan Screw	120	2	4" Bolt
32	2	Frame Pivot Bolt	77	1	Latch Housing	121	4	Weight Rack Bolt
33	2	Frame Pivot Spacer	78	1	Console	122	4	Nut
34	1	Tension Bushing	79	1	Stop Bracket	123	1	Left Handrail
35	1	Front Roller Adj. Bolt	80	2	Incline Pivot Nut	124	1	Right Handrail
36	1	Foot Rail Cap (Right)	81	8	Star Washer	125	1	Weight Rack
37	1	Motor Tension Nut	82	1	Base	126	2	1-lb. Weight
38	4	Motor Bolt	83	2	Incline Frame Bolt	#	1	4" Blue Wire, 2F
39	10	3/4" Screw	84	2	Motor Tension Washer	#	1	8" Green Wire, 2 Ring
40	1	Foot Rail Cap (Left)				#	1	User's Manual
41	1	Left Foot Rail	85	2	Latch Screw			
42	1	Front Roller/Pulley	86	2	Wheel Bolt			
43	1	Magnet	87	1	Console Base			

* Includes all parts shown in the box

These parts are not illustrated

EXPLODED DRAWING—Model No. DTL44950

R1104A

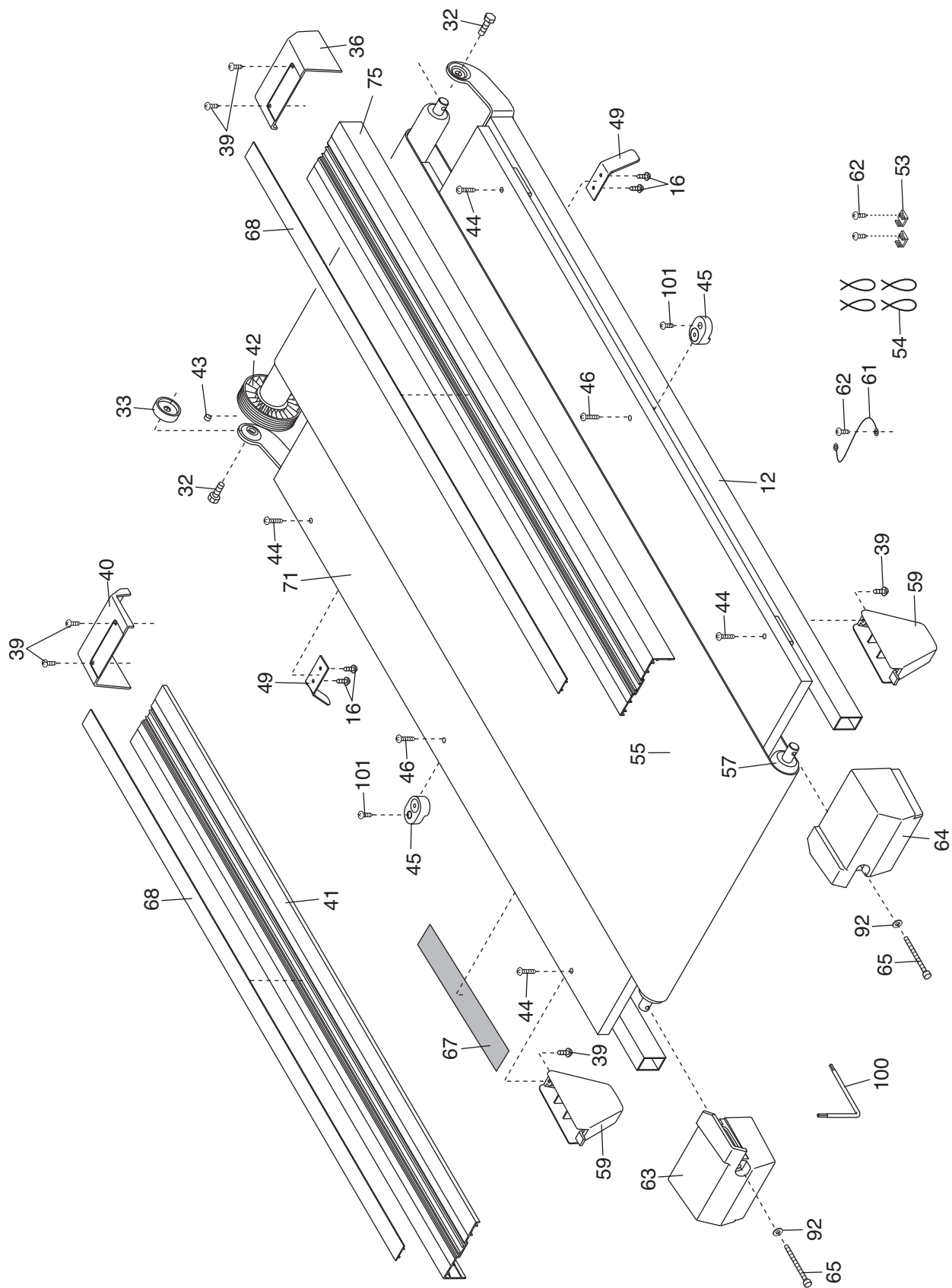

HOW TO ORDER REPLACEMENT PARTS

To order replacement parts, call our Customer Service Department toll-free at 1-888-533-1333, Monday through Friday, 6 a.m. until 6 p.m. Mountain Time (excluding holidays). Before calling, please note the following information:

- The MODEL NUMBER of the product (DTL44950)
- The NAME of the product (PROFORM CROSS TRAINER VX treadmill)
- The SERIAL NUMBER of the product (see the front cover of this manual)
- The KEY NUMBER and DESCRIPTION of the part(s) (see the PART LIST and the EXPLODED DRAWING on pages 28 to 31 of this manual)

LIMITED WARRANTY

ICON Health & Fitness, Inc. (ICON), warrants this product to be free from defects in workmanship and material, under normal use and service conditions. The drive motor is warranted for three (3) years after the date of purchase. The parts and labor are warranted for ninety (90) days after the date of purchase.

This warranty extends only to the original purchaser. ICON's obligation under this warranty is limited to replacing or repairing, at ICON's option, the product through one of its authorized service centers. All repairs for which warranty claims are made must be preauthorized by ICON. This warranty does not extend to any product or damage to a product caused by or attributable to freight damage, abuse, misuse, improper or abnormal usage or repairs not provided by an ICON authorized service center; products used for commercial or rental purposes; or products used as store display models. No other warranty beyond that specifically set forth above is authorized by ICON.

ICON is not responsible or liable for indirect, special or consequential damages arising out of or in connection with the use or performance of the product or damages with respect to any economic loss, loss of property, loss of revenues or profits, loss of enjoyment or use, costs of removal or installation or other consequential damages of whatsoever nature. Some states do not allow the exclusion or limitation of incidental or consequential damages. Accordingly, the above limitation may not apply to you.

The warranty extended hereunder is in lieu of any and all other warranties and any implied warranties of merchantability or fitness for a particular purpose is limited in its scope and duration to the terms set forth herein. Some states do not allow limitations on how long an implied warranty lasts. Accordingly, the above limitation may not apply to you.

This warranty gives you specific legal rights. You may also have other rights which vary from state to state.

ICON HEALTH & FITNESS, INC., 1500 S. 1000 W., LOGAN, UT 84321-9813