

PRO-FORM® 575 CROSSTRAINER

Model No. PFTL54706.0

Serial No. _____

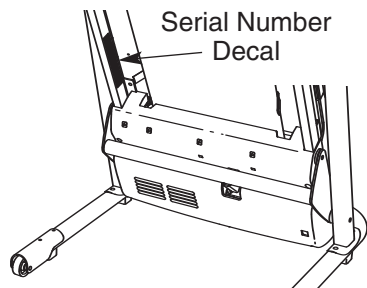

USER'S MANUAL

QUESTIONS?

As a manufacturer, we are committed to providing complete customer satisfaction. If you have questions, or if parts are damaged or missing, PLEASE CONTACT OUR CUSTOMER SERVICE DEPARTMENT DIRECTLY.

CALL TOLL-FREE:

1-888-533-1333

Mon.–Fri., 6 a.m.–6 p.m. MST

ON THE WEB:

www.proformservice.com

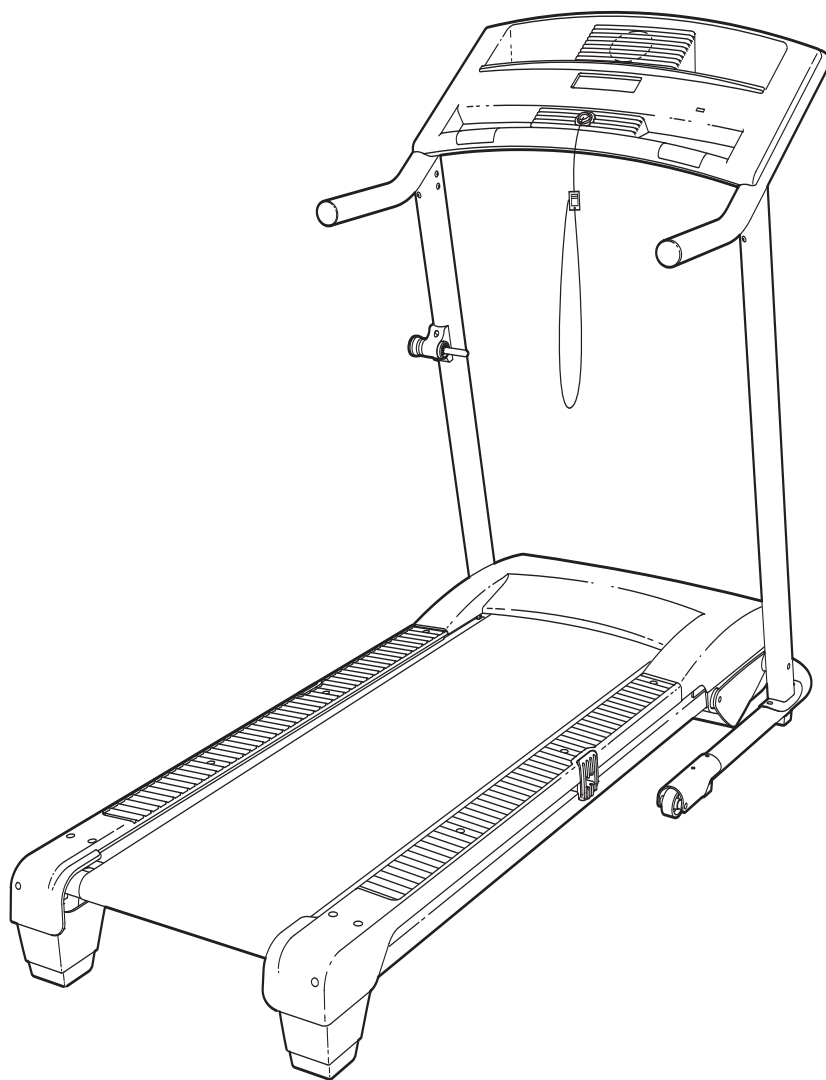

⚠ CAUTION

Read all precautions and instructions in this manual before using this equipment. Save this manual for future reference.



Visit our website at

www.proform.com

new products, prizes,
fitness tips, and much more!

PRO-FORM[®] 575 **CROSSTRAINER**

TABLE OF CONTENTS

IMPORTANT PRECAUTIONS3
BEFORE YOU BEGIN5
ASSEMBLY6
OPERATION AND ADJUSTMENT12
HOW TO FOLD AND MOVE THE TREADMILL21
MAINTENANCE AND TROUBLESHOOTING23
CONDITIONING GUIDELINES25
PART LIST27
EXPLODED DRAWING28
ORDERING REPLACEMENT PARTS	Back Cover
LIMITED WARRANTY	Back Cover

IMPORTANT PRECAUTIONS

⚠ WARNING: To reduce the risk of burns, fire, electric shock, or injury to persons, read the following important precautions and information before operating the treadmill.

1. It is the responsibility of the owner to ensure that all users of this treadmill are adequately informed of all warnings and precautions.
2. Use the treadmill only as described.
3. Place the treadmill on a level surface, with at least eight feet of clearance behind it and two feet on each side. Do not place the treadmill on any surface that blocks air openings. To protect the floor or carpet from damage, place a mat under the treadmill.
4. Keep the treadmill indoors, away from moisture and dust. Do not put the treadmill in a garage or covered patio, or near water.
5. Do not operate the treadmill where aerosol products are used or where oxygen is being administered.
6. Keep children under the age of 12 and pets away from the treadmill at all times.
7. The treadmill should not be used by persons weighing more than 250 pounds.
8. Never allow more than one person on the treadmill at a time.
9. Wear appropriate exercise clothes when using the treadmill. Do not wear loose clothes that could become caught in the treadmill. Athletic support clothes are recommended for both men and women. *Always wear athletic shoes; never use the treadmill with bare feet, wearing only stockings, or in sandals.*
10. When connecting the power cord (see page 12), plug the power cord into a surge suppressor (not included) and plug the surge suppressor into a grounded circuit capable of carrying 15 or more amps. No other appliance should be on the same circuit. Do not use an extension cord.
11. Use only a single-outlet surge suppressor that meets all of the specifications described on page 12. To purchase a surge suppressor, see your local PROFORM dealer or call the toll-free telephone number on the front cover of this manual and order part number 146148, or see your local electronics store.
12. Failure to use a properly functioning surge suppressor could result in damage to the control system of the treadmill. If the control system is damaged, the walking belt may change speed, accelerate, or stop unexpectedly, which may result in a fall and serious injury.
13. Keep the power cord and the surge suppressor away from heated surfaces.
14. Never move the walking belt while the power is turned off. Do not operate the treadmill if the power cord or plug is damaged, or if the treadmill is not working properly. (See **MAINTENANCE AND TROUBLESHOOTING** on page 23 if the treadmill is not working properly.)
15. Read, understand, and test the emergency stop procedure before using the treadmill (see **HOW TO TURN ON THE POWER** on page 13).
16. Never start the treadmill while you are standing on the walking belt. Always hold the handrails while using the treadmill.
17. The pulse sensor is not a medical device. Various factors, including your movement, may affect the accuracy of heart rate readings. The pulse sensor is intended only as an exercise aid in determining heart rate trends in general.
18. Use the included dumbbells only as described in this manual. Properly store the dumbbells in the dumbbell holders on the console when you are not using them. If the dumbbells are improperly stored, they may fall off the console, causing the user to trip.
19. The treadmill is capable of high speeds. Adjust the speed in small increments to avoid sudden jumps in speed.
20. Never leave the treadmill unattended while it is running. Always remove the key and unplug the power cord when the treadmill is not in use.

21. Do not attempt to raise, lower, or move the treadmill until it is properly assembled. (See ASSEMBLY on page 6 and HOW TO FOLD AND MOVE THE TREADMILL on page 21.) You must be able to safely lift 45 pounds (20 kg) to raise, lower, or move the treadmill.
22. When folding or moving the treadmill, make sure that the storage latch is fully closed.
23. Do not change the incline of the treadmill by placing objects under the treadmill.
24. Inspect and properly tighten all parts of the treadmill regularly.
25. Never drop or insert any object into any opening on the treadmill.

26. This treadmill is intended for in-home use only. Do not use this treadmill in a commercial, rental, or institutional setting.

27. **DANGER:** Always unplug the power cord immediately after use, before cleaning the treadmill, and before performing the maintenance and adjustment procedures described in this manual. Never remove the motor hood unless instructed to do so by an authorized service representative. Servicing other than the procedures in this manual should be performed by an authorized service representative only.

⚠ WARNING: Before beginning this or any exercise program, consult your physician. This is especially important for persons over the age of 35 or persons with pre-existing health problems. Read all instructions before using. ICON assumes no responsibility for personal injury or property damage sustained by or through the use of this product.

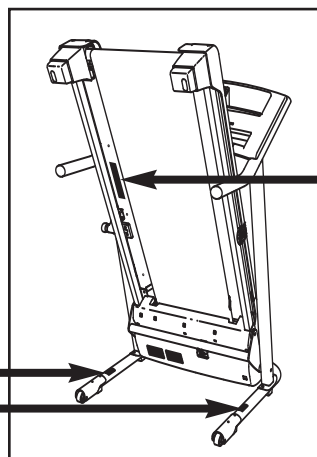

SAVE THESE INSTRUCTIONS

The decals shown here have been placed on the treadmill. If a decal is missing, or if it is not legible, call the toll-free telephone number on the front cover of this manual and order a free replacement decal. Apply the decal in the location shown. Note: The decals are not shown at actual size.



⚠ WARNING:

Protect yourself and others from risk of serious injury. Read the user's manual and :

-  *Stand only on the side rails when starting or stopping treadmill.
- *Change speed in small increments.
- *Hold handrails to prevent falling, and always wear the safety clip while operating treadmill.
- *Stop if you feel faint, dizzy, or short of breath.
- *Fully engage storage latch before treadmill is moved or stored.
- *Reduce incline to its lowest level before folding treadmill into storage position.
-  *Never allow children on or around treadmill.
- *Remove key when not in use.
-  *Keep clothing, fingers, and hair away from moving belt.
- *Never try to adjust or fix the belt while it is moving.
- *Always wear athletic shoes while operating treadmill.

BEFORE YOU BEGIN

Thank you for selecting the new PROFORM® 575 CROSSTRAINER treadmill. The 575 CROSS-TRAINER treadmill combines advanced technology with innovative design to let you enjoy an excellent form of cardiovascular exercise in the convenience and privacy of your home. And when you're not exercising, the unique 575 CROSSTRAINER treadmill can be folded up, requiring less than half the floor space of other treadmills.

For your benefit, read this manual carefully before you use the treadmill. If you have questions after reading this manual, please see the front cover of this

manual. To help us assist you, note the product model number and serial number before contacting us. The model number of the treadmill is PFTL54706.0. The serial number can be found on a decal attached to the treadmill (see the front cover of this manual for the location).

To avoid a registration fee for any service needed under warranty, you must register the treadmill at www.proformservice.com/registration.



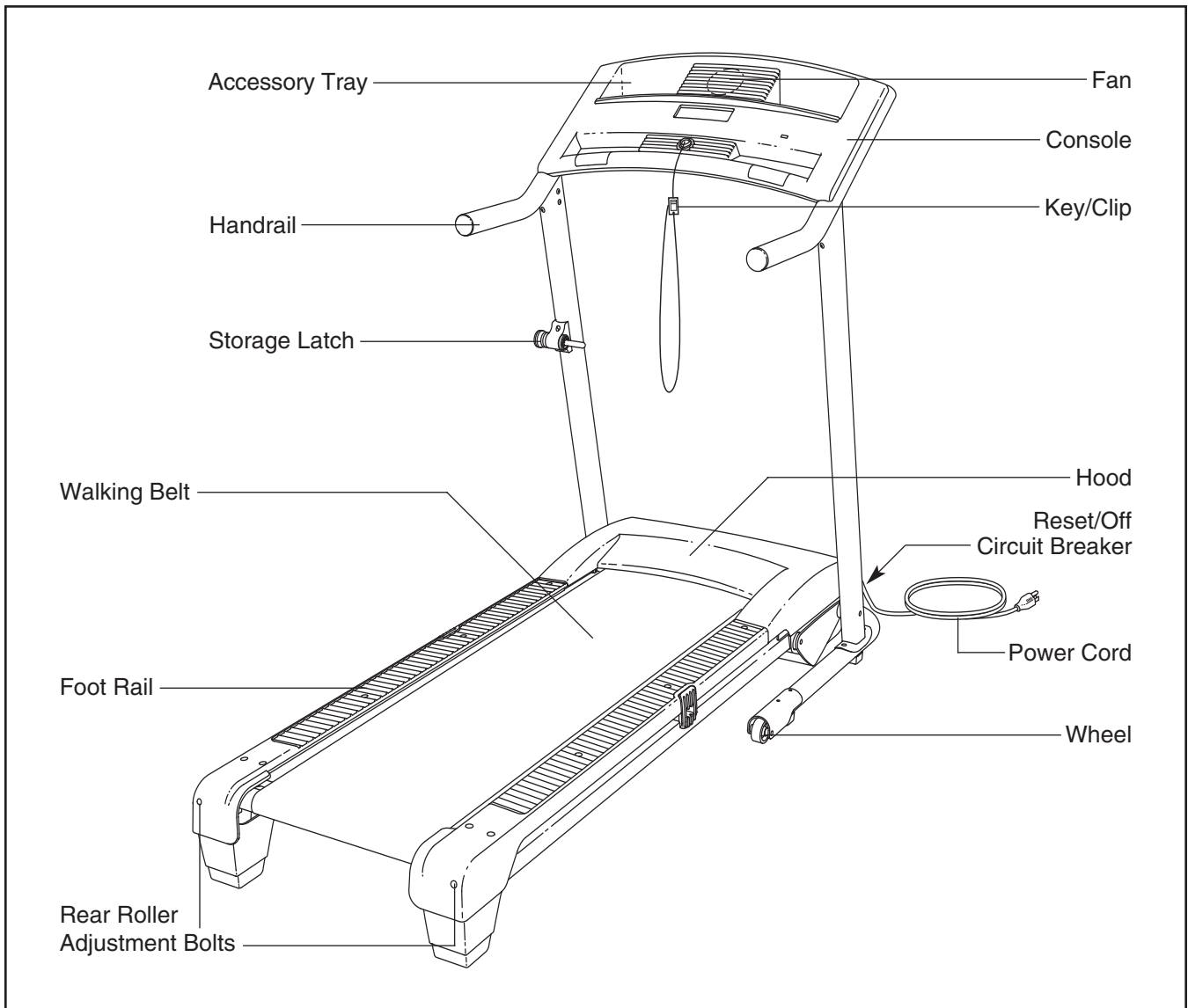

Before reading further, please review the drawing below and familiarize yourself with the labeled parts.



ASSEMBLY

To hire an authorized service technician to assemble the treadmill, call toll-free 1-800-445-2480.

Assembly requires two persons. Set the treadmill in a cleared area and remove all packing materials; **do not dispose of the packing materials until assembly is completed.** Note: The underside of the treadmill walking belt is coated with high-performance lubricant. During shipping, a small amount of lubricant may be transferred to the top of the walking belt or the shipping carton. This does not affect treadmill performance. If there is lubricant on top of the walking belt, simply wipe off the lubricant with a soft cloth and a mild, non-abrasive cleaner.

In addition to the included hex keys , assembly requires a phillips screwdriver , an adjustable wrench , and needlenose pliers .

Use the drawings below to identify the hardware used during assembly. **Note: If a part is not in the parts bag, check to see if it has been preattached to one of the parts to be assembled.** Extra hardware may be included. **To avoid damaging plastic parts, do not use power tools for assembly.**

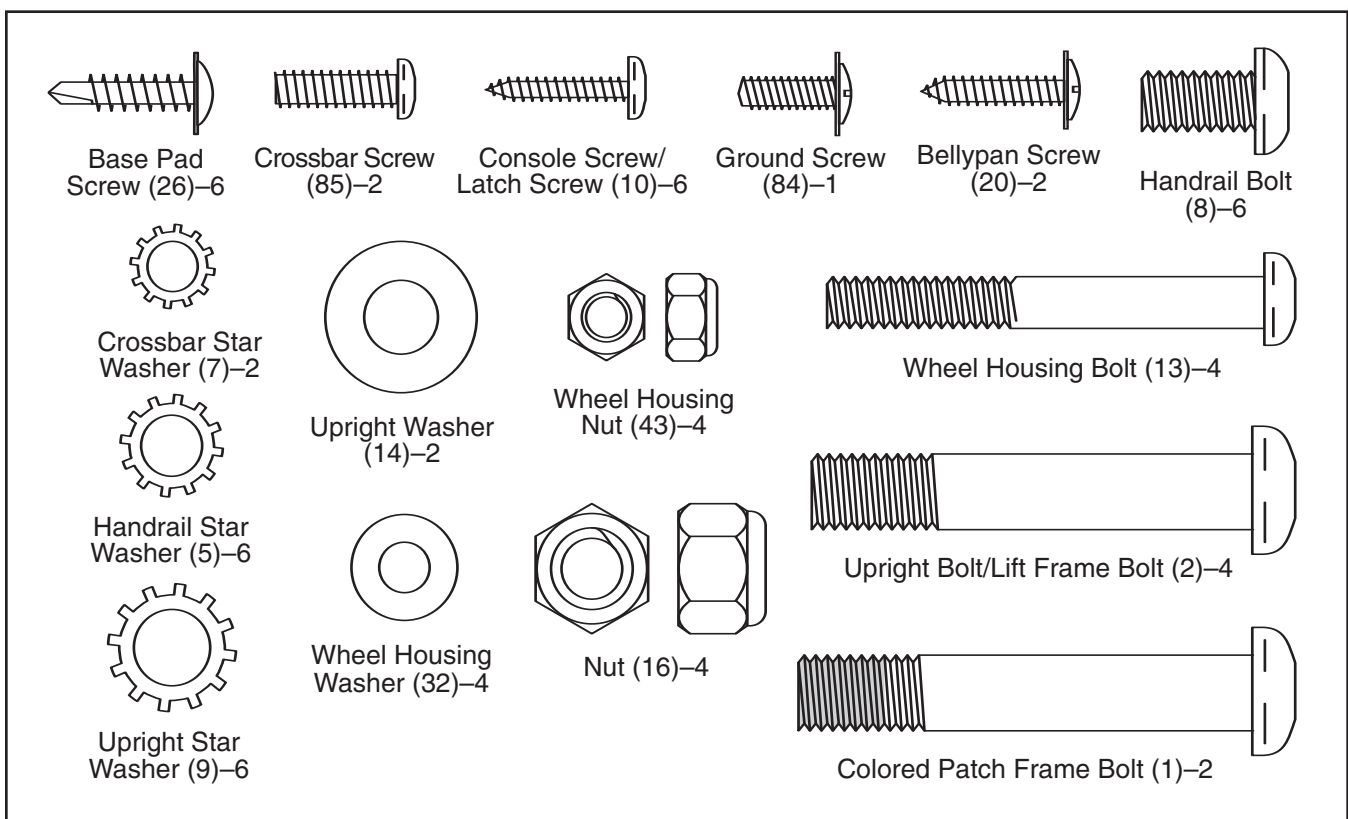

1. Make sure that the power cord is unplugged.

Have a second person hold the Base (52) in the position shown.

Attach six Base Pads (63) to the Base (52) with six Base Pad Screws (26).

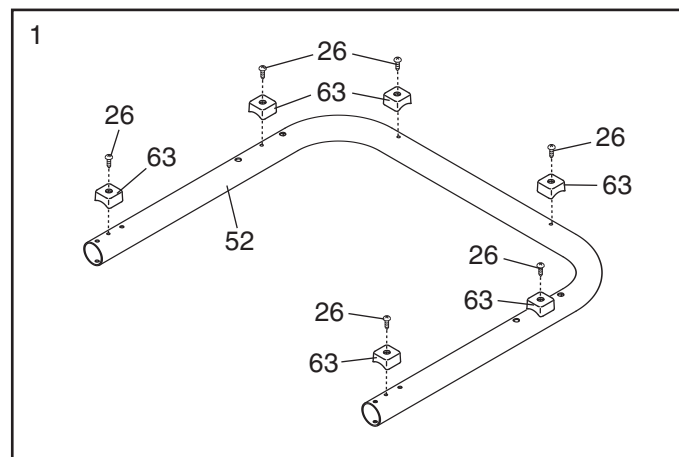

- Have a second person hold the Base (52) in the position shown.

Identify the Left Upright (53) (the Right Upright [54] has a large hole near the lower end).

Hold the Left Upright (53) so the two small holes for the latch assembly are on top as shown. Insert two Upright Bolts (2) into the bracket on the Left Upright. Attach the Left Upright to the Base (52) with the Upright Bolts, two Upright Star Washers (9) and two Nuts (16). Do not tighten the Nuts yet.

Attach the Right Upright (54) to the Base (52) in the same way.

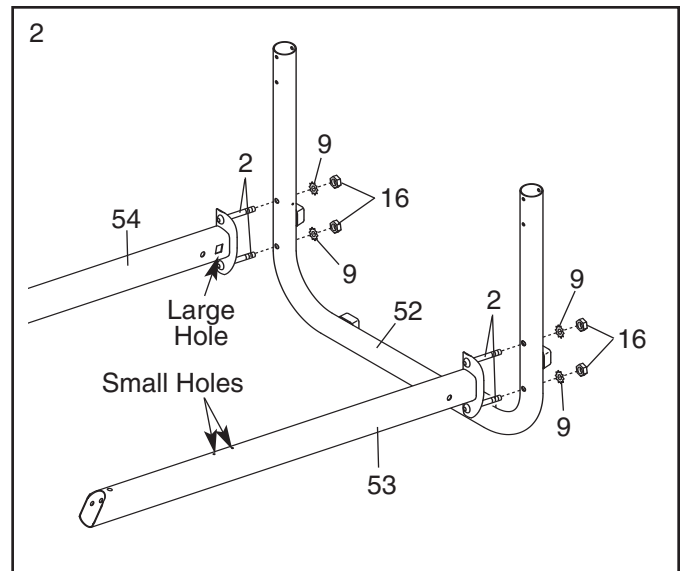

- Slide the two Wheel Housings (45) onto the Base (52). Attach each Wheel Housing with two Wheel Housing Bolts (13), two Wheel Housing Washers (32), and two Wheel Housing Nuts (43).

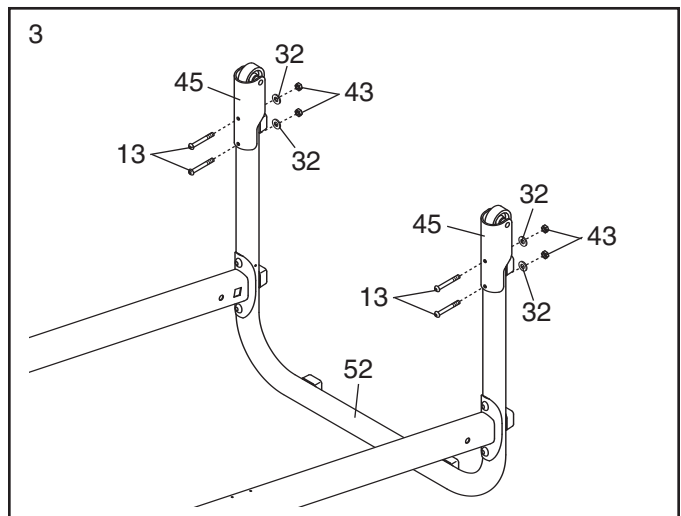

- Position the Base (52) as close to the front of the treadmill as possible, as shown.

See drawing 4a. Locate the wire tie in the lower end of the Right Upright (54). Tie the wire tie securely around the end of the Wire Harness (39). Then, locate the other end of the wire tie in the upper end of the Right Upright. Pull that end of the wire tie until the Wire Harness is extending from the upper end of the Right Upright. Secure the Wire Harness to the Right Upright so that it will not fall inside.

See drawing 4b. Press the indicated Grommet (49) into the Right Upright (54).

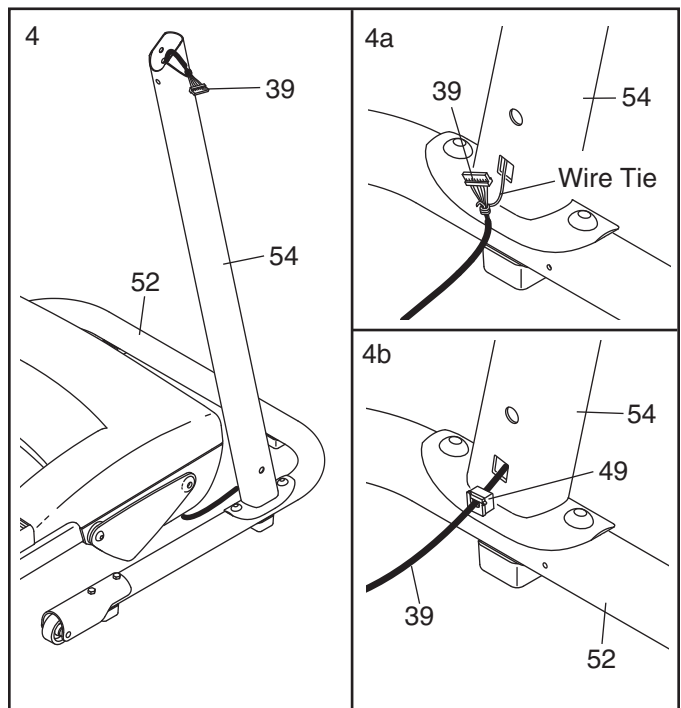

- See the left inset drawing. Identify the two Frame Spacers (11). Open the included packet of grease, and apply grease to both sides of both Frame Spacers. Then, identify the outer side of each Frame Spacer.

Hold a Frame Spacer (11) between the Right Upright (54) and the Lift Frame (23), **with the outer side of the Frame Spacer facing the Right Upright**. Attach the Right Upright to the Lift Frame with a Colored Patch Frame Bolt (1), an Upright Washer (14), and an Upright Star Washer (9); **do not tighten the Colored Patch Frame Bolt yet**.

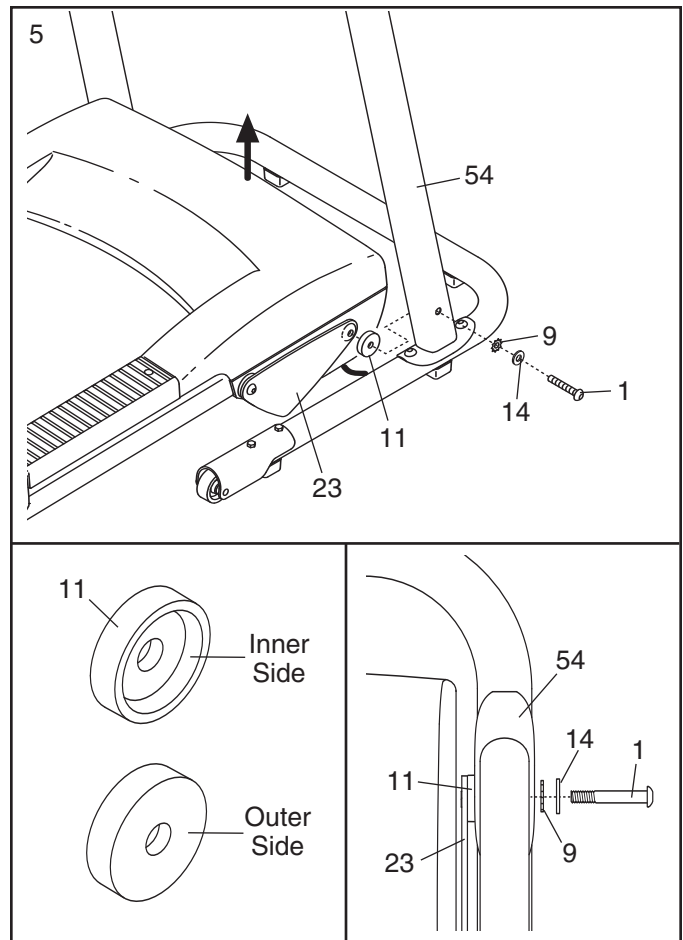

- See the left inset drawing. Identify the outer side of the remaining Frame Spacer (11).

Hold the Frame Spacer (11) between the Left Upright (53) and the Lift Frame (23), **with the outer side of the Frame Spacer facing the Left Upright**. Attach the Left Upright to the Lift Frame with a Colored Patch Frame Bolt (1), an Upright Washer (14), and an Upright Star Washer (9); **do not tighten the Colored Patch Frame Bolt yet**.

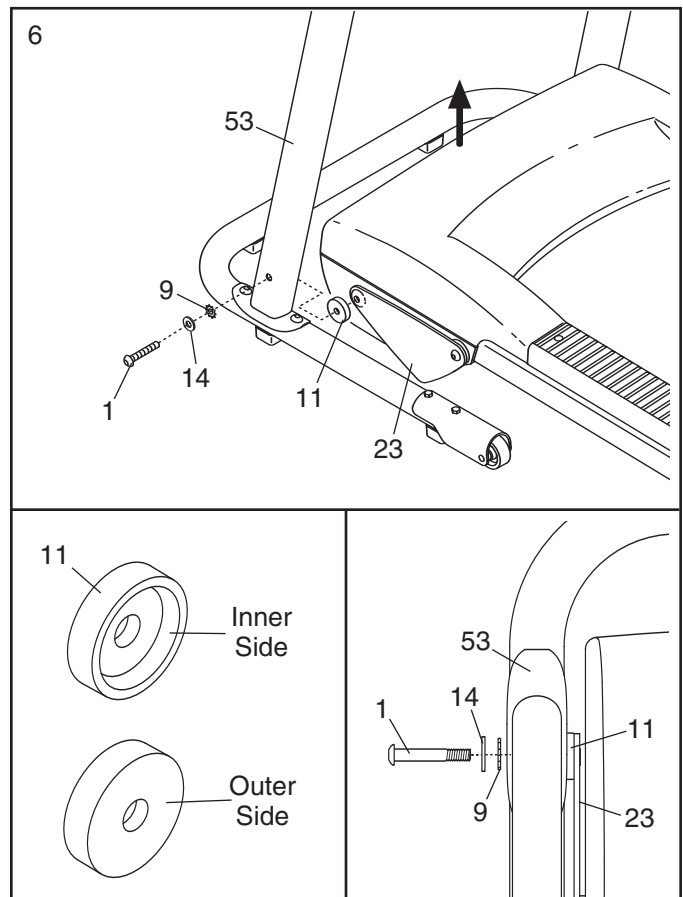

- Set the Console Assembly (91) face down on a soft surface to avoid scratching the Console Assembly. Hold the Right Handrail (33), which has a large hole in one side, near the Console.

Next, insert the console wire and the tie into the hole in the side of the Right Handrail (33). Using needlenose pliers, pull the console wire out of the hole near the bracket on the Right Handrail.

Then, set the Right Handrail (33) on the Console Assembly (91). **Make sure that no wires are pinched.** Start a Crossbar Screw (85) with a Crossbar Star Washer (7) into the Right Handrail, and then start two Console Screws (10) into the Right Handrail. **Tighten the Crossbar Screw and then tighten the two Console Screws; do not overtighten the Screws.**

Attach the Left Handrail (not shown) to the Console Assembly (91) in the same way. Note: There are no wires on the left side.

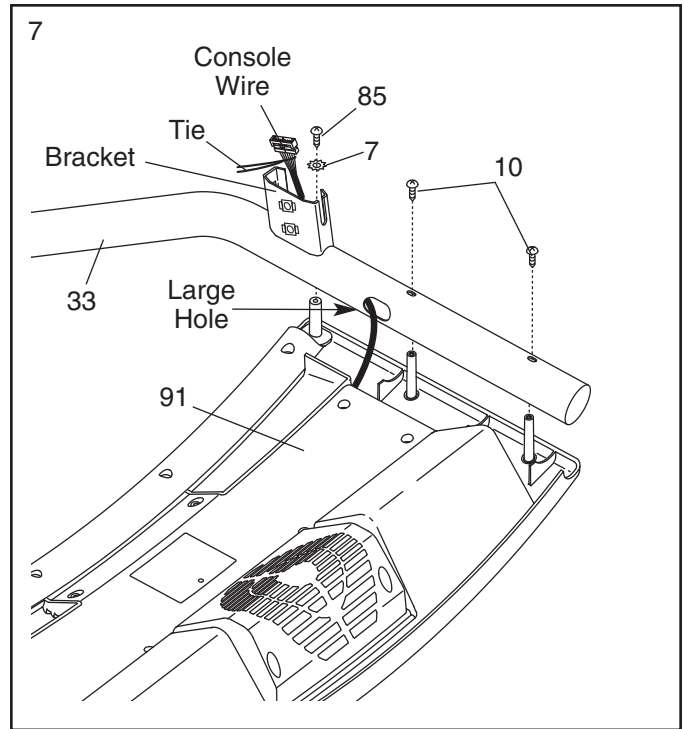

- See drawing 8a. If there is a guard on the end of the Console Wire, press the indicated tab and remove the guard with needlenose pliers. Discard the guard.

With the help of a second person, hold the Console Assembly (91) near the Right Upright (54).

Remove the wire tie from the Wire Harness (39). Connect the Wire Harness to the console wire harness. **Make sure to connect the connectors properly (see drawing 8b). The connectors should slide together easily and snap into place.** If they do not, turn one connector and try again. **IF THE CONNECTORS ARE NOT CONNECTED PROPERLY, THE CONSOLE MAY BE DAMAGED WHEN THE POWER IS TURNED ON.** Insert the connectors and the excess wire downward into the Right Upright (54).

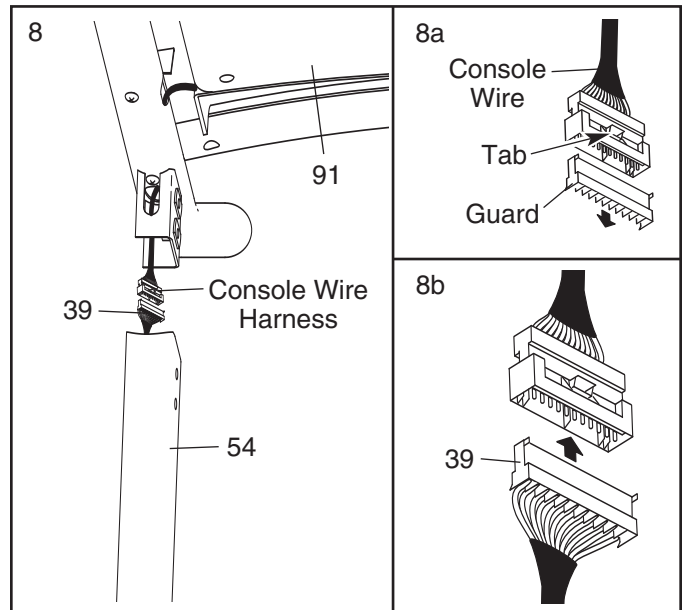

- Attach the Console Assembly (91) to the Right Upright (54) and the Left Upright (53) with four four Handrail Bolts (8) and four Handrail Star Washers (5). **Make sure that no wires are pinched. Start all four Handrail Bolts but do not tighten them yet.**

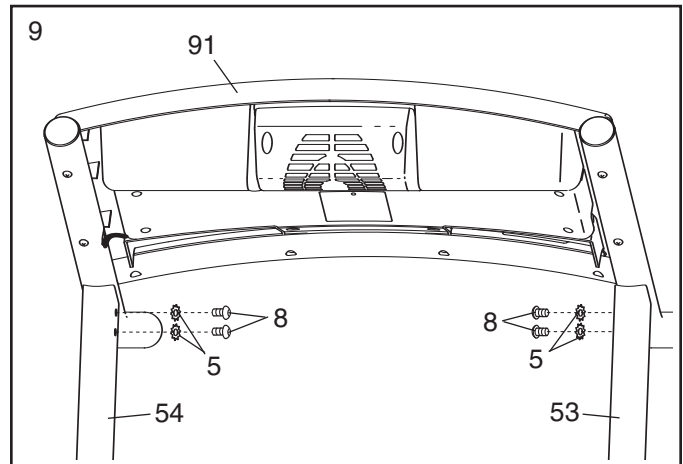

10. Start two Handrail Bolts (8) with two Handrail Star Washers (5) into the Uprights (53, 54). Then, firmly tighten all six Handrail Bolts.

With the help of a second person, carefully lower the Uprights (53, 54) to the floor.

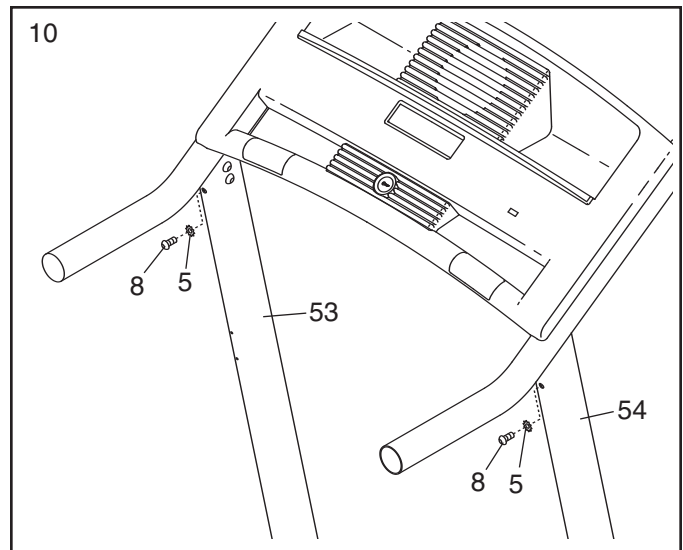

11. Attach the ground wire on the Wire Harness (39) to the indicated hole in the Base (52) with a Ground Screw (84).

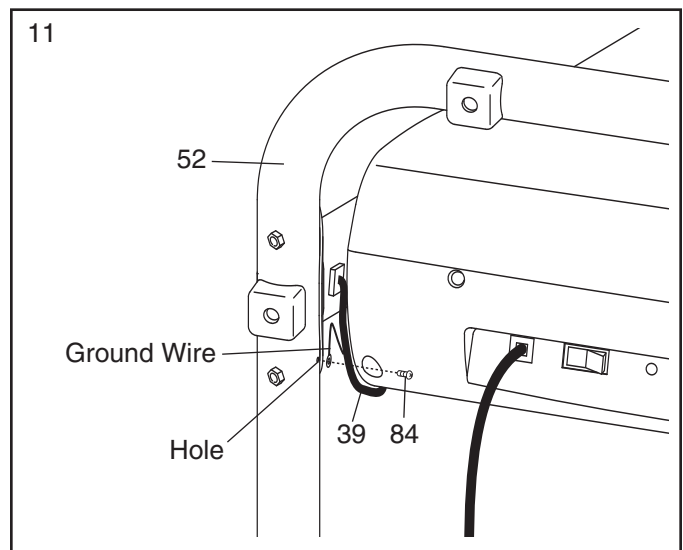

12. Tighten two Belly Pan Screws (20) into the Belly Pan (66) and the Hood (65). **Be careful not to overtighten the Belly Pan Screws.**

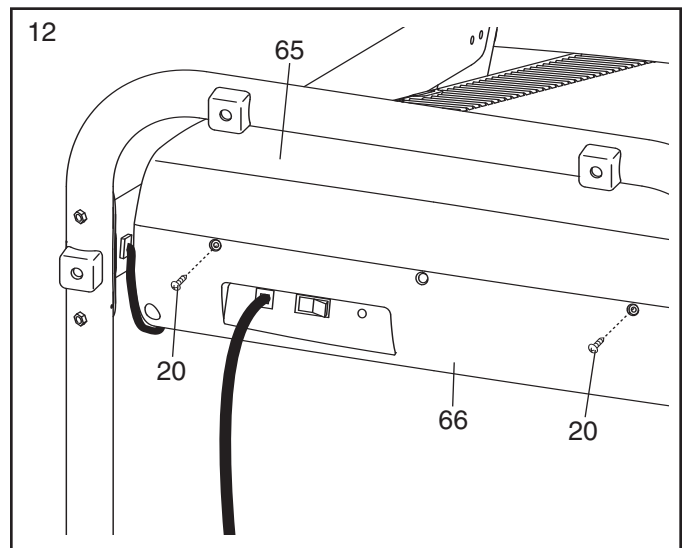

13. See the lower drawing. Position the Uprights (53, 54) so that the treadmill Frame (51) is centered between them.

Firmly tighten the two Colored Patch Frame Bolts (1) and the four Upright Bolts (2). **Be careful not to overtighten the Colored Patch Frame Bolts.**

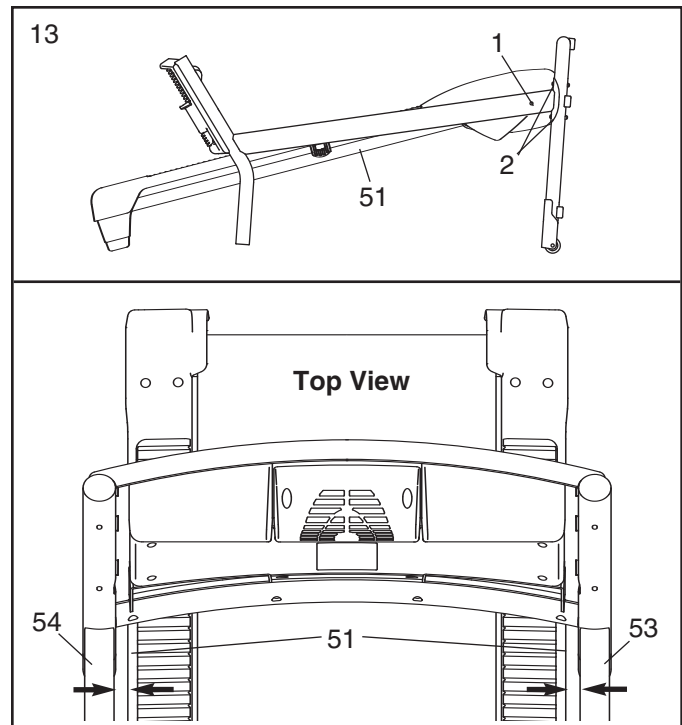

14. Attach the Latch Housing (48) to the Left Upright (53) with two Latch Screws (10); **start both Latch Screws before tightening them. Make sure that the large hole in the Latch Housing is on the indicated side.**

Remove the knob from the pin. Make sure that the collar and the spring are on the pin. (Note: If there are two collars, place one on each side of the spring.) Insert the pin into the Latch Housing (48). Then, tighten the knob onto the pin.

Plug in the power cord (see OPERATION AND ADJUSTMENT on page 12). Next, **change the incline of the treadmill to the lowest level as described on page 14. If this is not done, the latch may not hold the treadmill in the storage position.**

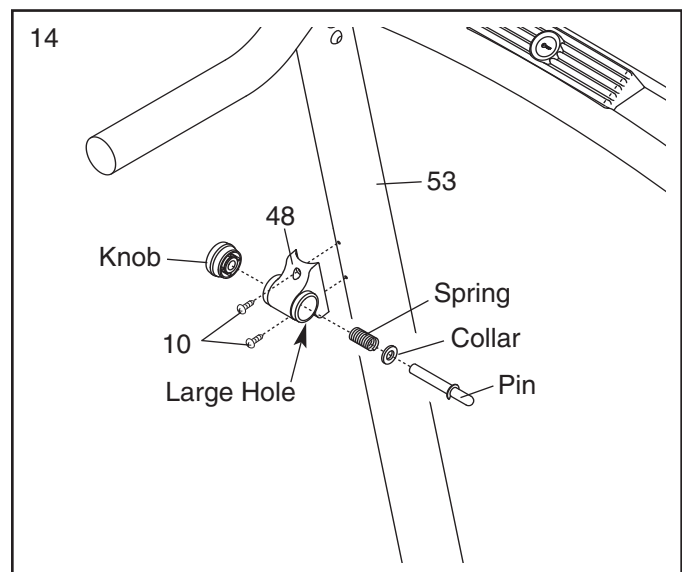

15. **Make sure that all parts are properly tightened before you use the treadmill.** Keep the included hex key in a secure place. The hex key is used to adjust the walking belt (see page 24). To protect the floor or carpet, place a mat under the treadmill.

OPERATION AND ADJUSTMENT

THE PRE-LUBRICATED WALKING BELT

Your treadmill features a walking belt coated with high-performance lubricant. **IMPORTANT: Never apply silicone spray or other substances to the walking belt or the walking platform. Such substances will deteriorate the walking belt and cause excessive wear.**

HOW TO PLUG IN THE POWER CORD

⚠ DANGER: Improper connection of the equipment-grounding conductor can result in an increased risk of electric shock. Check with a qualified electrician or serviceman if you are in doubt as to whether the product is properly grounded. Do not modify the plug provided with the product—if it will not fit the outlet, have a proper outlet installed by a qualified electrician.

Your treadmill, like any other type of sophisticated electronic equipment, can be seriously damaged by sudden voltage changes in your home's power. Voltage surges, spikes, and noise interference can result from weather conditions or from other appliances being turned on or off. **To decrease the possibility of your treadmill being damaged, always use a surge suppressor with your treadmill (see drawing 1 at the right). To purchase a surge suppressor, see your local PROFORM dealer or call the toll-free telephone number on the front cover of this manual and order part number 146148, or see your local electronics store.**

Use only a single-outlet surge suppressor that is UL 1449 listed as a transient voltage surge suppressor (TVSS). The surge suppressor must have a UL suppressed voltage rating of 400 volts or less and a minimum surge dissipation of 450 joules. The surge suppressor must be electrically rated for 120 volts AC and 15 amps. There must be a monitoring light on the surge suppressor to indicate whether it is functioning properly. Failure to use a properly functioning surge suppressor could result in damage to the control system of the treadmill. If the control system is damaged, the walking belt may change speed, accelerate or stop unexpectedly, which may result in a fall and serious injury.

This product must be grounded. If it should malfunction or break down, grounding provides a path of least resistance for electric current to reduce the risk of elec-

tric shock. This product is equipped with a cord having an equipment-grounding conductor and a grounding plug. **Plug the power cord into a surge suppressor, and plug the surge suppressor into an appropriate outlet that is properly installed and grounded in accordance with all local codes and ordinances. Important: The treadmill is not compatible with GFCI-equipped outlets.**

This product is for use on a nominal 120-volt circuit, and has a grounding plug that looks like the plug illustrated in drawing 1 below. A temporary adapter that looks like the adapter illustrated in drawing 2 may be used to connect the surge suppressor to a 2-pole receptacle as shown in drawing 2 if a properly grounded outlet is not available.

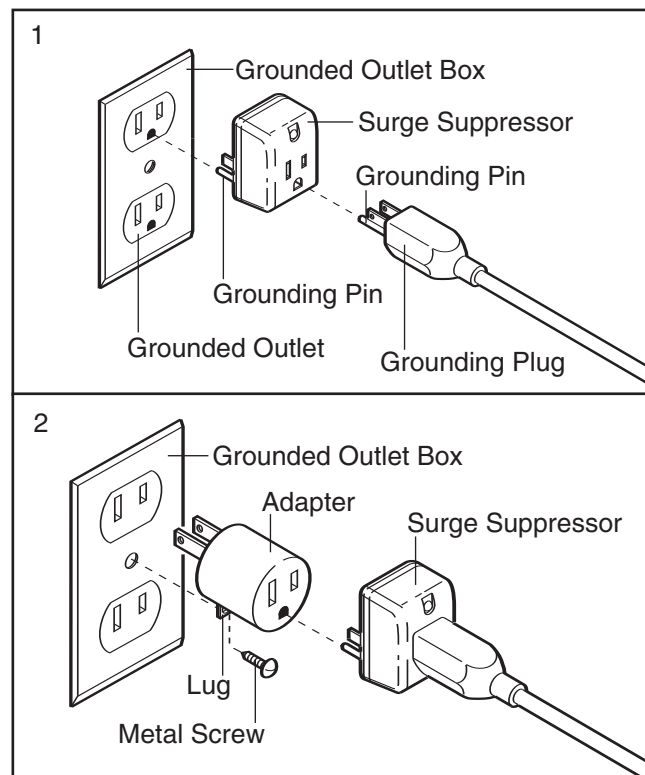

The temporary adapter should be used only until a properly grounded outlet (drawing 1) can be installed by a qualified electrician.

The green-colored rigid ear, lug, or the like extending from the adapter must be connected to a permanent ground such as a properly grounded outlet box cover. Whenever the adapter is used it must be held in place by a metal screw. **Some 2-pole receptacle outlet box covers are not grounded. Contact a qualified electrician to determine if the outlet box cover is grounded before using an adapter.**

CONSOLE DIAGRAM

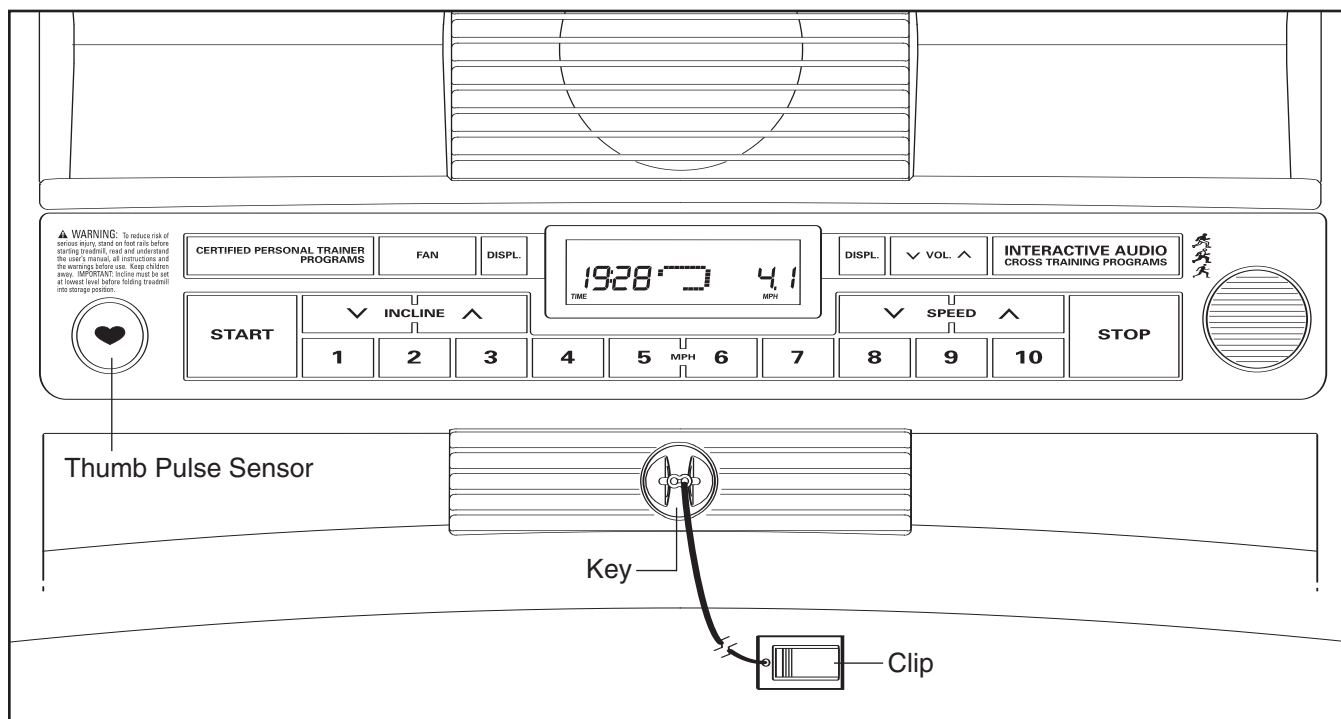

FEATURES OF THE CONSOLE

The revolutionary treadmill console offers a selection of features designed to make your workouts more effective.

When you select the manual mode of the console, you can change the speed and incline of the treadmill with the touch of a button. As you exercise, the console will display continuous exercise feedback. You can even measure your heart rate using the thumb pulse sensor or the optional chest pulse sensor (see page 20 for information about the optional chest pulse sensor).

The console also features six interactive cross training programs designed to help you to burn calories and enhance your cardiovascular system while toning and strengthening your muscles. The cross training programs automatically control the speed and incline of the treadmill and prompt you to perform a variety of strength exercises during your workout. There are two whole body, two upper body, and two lower body cross training programs to choose among. Note: The

strength exercises require the use of dumbbells and an inflatable exercise ball (not included). **To purchase an exercise ball or additional dumbbells, call the toll-free telephone number on the front cover of this manual.**

In addition, the console offers two preset programs that automatically control the speed and incline of the treadmill while guiding you through an effective workout.

To use the manual mode of the console, follow the steps beginning on page 14. **To use a cross training program**, see page 16. **To use a preset program**, see page 18.

Note: If there is a sheet of clear plastic on the face of the console, remove the plastic. To prevent damage to the walking platform, wear clean athletic shoes while using the treadmill. The first time the treadmill is used, observe the alignment of the walking belt, and center the walking belt if necessary (see page 24).

HOW TO TURN ON THE POWER

Plug in the power cord (see page 12). Next, locate the reset/off circuit breaker near the power cord. Make sure that the circuit breaker is in the reset position.

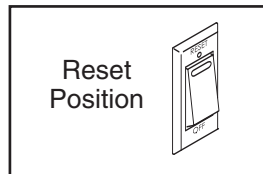

Next, stand on the foot rails of the treadmill. Find the clip attached to the key (see the drawing on page 13) and slide the clip onto the waistband of your clothes. Then, insert the key into the console. After a moment, the display will light. **Important: In an emergency situation, the key can be pulled from the console, causing the walking belt to slow to a stop. Test the clip by carefully taking a few steps backward; if the key is not pulled from the console, adjust the position of the clip.**

HOW TO USE THE MANUAL MODE

1 Insert the key into the console.

See HOW TO TURN ON THE POWER above.

2 Select the manual mode.

When the key is inserted, the manual mode will be selected. If you have

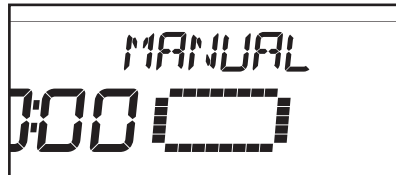

selected a program, reselect the manual mode by pressing either of the two Programs buttons repeatedly until the word "MANUAL" and a track appear in the display.

3 Start the walking belt.

To start the walking belt, press the Start button, the Speed increase button, or one of the speed buttons numbered 1 to 10.

If the Start button or the Speed increase button is pressed, the walking belt

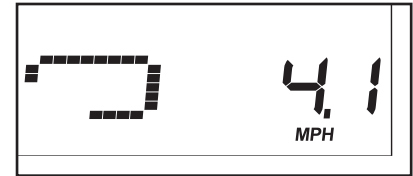

will begin to move at 1 mph. As you exercise, change the speed of the walking belt as desired by pressing the Speed increase and decrease buttons. Each time a button is pressed, the speed setting will change by 0.1 mph; if a button is held down, the speed setting will change in increments of 0.5 mph. Note: After the buttons are pressed, it may take a moment for the walking belt to reach the selected speed setting.

If one of the numbered speed buttons is pressed, the walking belt will gradually change speed until it reaches the selected speed setting.

To stop the walking belt, press the Stop button. The time will begin to flash in the display. To restart the walking belt, press the Start button, the Speed increase button, or one of the numbered speed buttons.

4 Change the incline of the treadmill as desired.

To change the incline of the treadmill, press the Incline increase and decrease



buttons. Each time a button is pressed, the incline will change by 0.5%. Note: After the buttons are pressed, it may take a moment for the treadmill to reach the selected incline setting.

5 Follow your progress with the display.

When the manual mode is selected, the display will show a track that represents 1/4 mile. As you walk or run, indicators will appear in succession around the track until the entire track appears. The track will then disappear and the indicators will again begin to appear in succession.

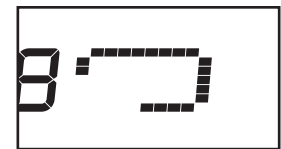

The left side of the display can show the elapsed time or the approximate number of calories you have burned while walking or running. Press the left Display (DISPL.) button once or twice to select the information that you want to view. Note: When a program is selected, the display will show the time remaining in the program instead of the elapsed time. The left side of the display will also show your heart rate when you use the thumb pulse sensor or the optional chest pulse sensor.



The right side of the display can show the speed of the walking belt or the distance that you have walked or run. Press the right Display (DISPL.) button once or twice to select the information that you want to view.



When the manual mode is selected, the upper part of the display will show the incline level of the treadmill whenever you press the Incline increase or decrease button.



Note: The console can display speed and distance in either miles or kilometers. To change the unit of measurement, see THE INFORMATION MODE on page 20. **Note: For simplicity, all instructions in this section refer to miles.**

To reset the display, press the Stop button, remove the key, and then reinsert the key.

6 Measure your heart rate if desired.

Note: If you use the thumb pulse sensor and the optional chest pulse sensor at the same time, the console will not display your heart rate accurately.

To measure your heart rate, **stand on the foot rails** and place your left thumb on the pulse sensor (see the drawing on page 13). **Do not press too hard, or the circulation in your thumb will be restricted and your pulse may not be detected.** When your pulse is detected, a heart-shaped indicator in the left side of the display will flash each time your heart beats, one or two dashes will appear, and then your heart rate will be shown. **For the most accurate heart rate reading, hold your thumb on the pulse sensor for at least 15 seconds.**

If the displayed heart rate appears to be too high or too low, or if your heart rate is not displayed, lift your thumb for a few seconds, and then reposition your thumb on the pulse sensor. Remember to stand still while measuring your heart rate.

7 Turn on the fan if desired.

To turn on the fan at high speed, press the Fan button; the words FAN: HIGH will appear in the upper part of the display. To turn on the fan at low speed, press the button a second time; the words FAN: LOW will appear in the display. To turn off the fan, press the button a third time; the words FAN: OFF will appear in the display. Note: If the fan is on when the walking belt stops, the fan will automatically turn off after a few minutes.

8 When you are finished exercising, remove the key from the console.

Step onto the foot rails, press the Stop button, and **adjust the incline of the treadmill to the lowest setting. The incline must be at the lowest setting when you fold the treadmill to the storage position or you will damage the treadmill.** Next, remove the key from the console and put it in a secure place. **Note: If the display remains lit after the key is removed, the console is in the “demo” mode. See page 20 and turn off the demo mode.**

When you are finished using the treadmill, switch the reset/off circuit breaker to the “off” position and unplug the power cord.

HOW TO USE A CROSS TRAINING PROGRAM

1 Insert the key into the console.

See HOW TO TURN ON THE POWER on page 14.

2 Select one of the six cross training programs.

To select a cross training program, press the Interactive Audio Cross Training Programs button repeatedly until the desired program is selected. When a cross training program is selected, the name of the program and the program time will appear in the display, a profile of the speed settings of the program will scroll across the display, and the maximum speed setting of the program will flash in the display for a few seconds.

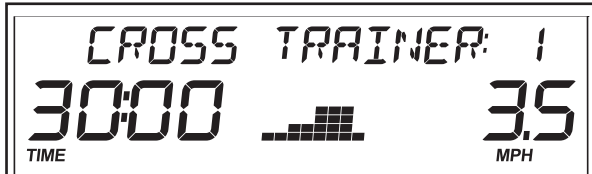

3 Press the Start button to start the program.

A moment after the button is pressed, the treadmill will automatically adjust to the first speed and incline settings of the program. Hold the handrails and begin walking.

The voice of a personal trainer will guide you through the program. To adjust the sound level, press the volume (VOL.) increase and decrease buttons. Note: If you do not hear the voice of the personal trainer when you press the volume buttons, see THE INFORMATION MODE on page 20.

Each program is divided into 25, 30, or 45 one-minute segments. One speed setting and one incline setting are programmed for most segments. (Note: The same speed setting and/or incline setting may be programmed for two or more consecutive segments.) During other segments, the console will prompt you to perform strength exercises.

The speed setting for the first segment will be shown in the flashing Current Segment

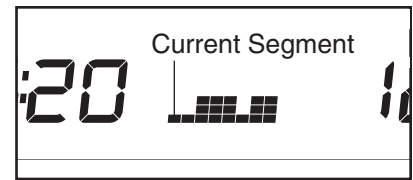

Column of the profile. (The incline settings are not shown in the profile.) The speed settings for the next several segments will be shown in the columns to the right.

When only three seconds remain in the first segment of the program, both the Current Segment column and the column to the right will flash and a series of tones will sound. If the speed and/or incline of the treadmill is about to change, the speed setting and/or incline setting will flash in the display to alert you.

When the first segment is completed, *all speed settings will move one column to the left.* The speed setting for the second segment will then be shown in the flashing Current Segment column and the treadmill will automatically adjust to the speed and incline settings for the second segment. Note: If all the indicators in the Current Segment column are lit, *the speed settings may move downward* so that only the highest indicators appear in the display.

If the speed or incline setting for the current segment is too high or too low, you can manually override the setting by pressing the Speed and Incline buttons. Every few times a Speed button is pressed, an additional indicator will appear or disappear in the Current Segment column; if any of the columns to the right of the Current Segment column have the same number of lit indicators as the Current Segment column, an additional indicator may appear or disappear in those columns as well. **Important: When the current segment of the program ends, the treadmill will automatically adjust to the speed and incline settings for the next segment.**

To stop the program at any time, press the Stop button. The time will begin to flash in the display. To restart the program, press the Start button. The walking belt will begin to move at 1 mph. When the next segment of the program begins, the treadmill will automatically adjust to the speed and incline settings for that segment.

4 Perform the first strength exercise when prompted.

When the first strength exercise segment begins (only one indicator will flash in the Current Segment column), the walking belt will slow to a stop and the name of the first strength exercise will appear in the display for a few seconds.



Next, the personal trainer will tell you the recommended number of repetitions for the first strength exercise.

Remove the clip from the waistband of your clothes, step off the treadmill, and prepare to begin the first strength exercise. The personal trainer and the display will count the repetitions; perform one repetition of the exercise on each count. Exercise with a slow, steady motion; do not perform more than one repetition for each count.

Note: Refer to the accompanying exercise chart to see the correct form for each exercise. When performing lunges, alternate legs with each repetition. When performing dumbbell rows, perform half the repetitions with your right arm and half the repetitions with your left arm. The strength exercises require the use of dumbbells and an inflatable exercise ball (not included). **To purchase an exercise ball or additional dumbbells, call the toll-free telephone number on the front cover of this manual.**

5 Continue the cross training program.

When you have performed the recommended number of repetitions, the words PRESS START will appear in the display. To continue the cross training program, step onto the treadmill, **slide the clip back onto the waistband of your clothes**, and press the Start button. The treadmill will automatically adjust to the speed and incline settings for the next segment.



The program will continue in this way until the last segment ends. The walking belt will then slow to a stop.

6 Follow your progress with the display.

See step 5 on pages 14 and 15.

7 Measure your heart rate if desired.

See step 6 on page 15.

8 Turn on the fan if desired.

See step 7 on page 15.

9 When you are finished exercising, remove the key from the console.

See step 8 on page 15.

HOW TO USE A PRESET PROGRAM

1 Insert the key into the console.

See HOW TO TURN ON THE POWER on page 14.

2 Select a preset program.

To select one of the two preset programs, press the Certified Personal Trainer Programs button once or twice. When a preset program is selected, the name of the program and the program time will appear in the display and a profile of the speed settings of the program will scroll across the display. In addition, the maximum speed setting of the program will flash in the display for a few seconds.

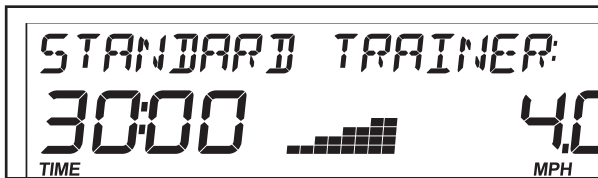

3 Press the Start button to start the program.

A moment after the button is pressed, the treadmill will automatically adjust to the first speed and incline settings of the program. Hold the handrails and begin walking.

Each program is divided into 30 one-minute segments. One speed setting and one incline setting are programmed for each segment. Note: The same speed setting and/or incline setting may be programmed for two or more consecutive segments.

The speed setting for the first segment will be shown in the flashing Current Segment column in the display. (The incline settings are not shown in

the display.) The speed settings for the next several segments will be shown in the columns to the right.

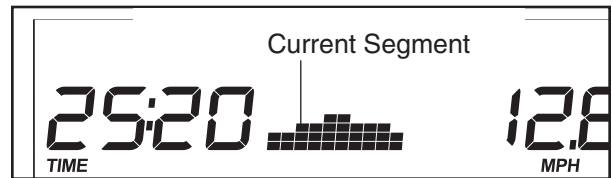

When only three seconds remain in the first segment of the program, both the Current Segment column and the column to the right will flash and a series of tones will sound. If the speed and/or incline of the treadmill is about to change, the speed setting and/or incline setting will flash in the display to alert you.

When the first segment is completed, *all speed settings will move one column to the left.* The speed setting for the second segment will then be shown in the flashing Current Segment column and the treadmill will automatically adjust to the speed and incline settings for the second segment. Note: If all the indicators in the Current Segment column are lit, the speed settings may move downward so that only the highest indicators appear in the display.

If the speed or incline setting for the current segment is too high or too low, you can manually override the setting by pressing the Speed and Incline buttons. Every few times a Speed button is pressed, an additional indicator will appear or disappear in the Current Segment column.

Important: When the current segment of the program ends, the treadmill will automatically adjust to the speed and incline settings for the next segment.

To stop the program at any time, press the Stop button. The time will begin to flash in the display. To restart the program, press the Start button. The walking belt will begin to move at 1 mph. When the next segment of the program begins, the treadmill will automatically adjust to the speed and incline settings for that segment.

The program will continue in this way until the last segment ends. The walking belt will then slow to a stop.

4 Follow your progress with the display.

See step 5 on pages 14 and 15.

5 Measure your heart rate if desired.

See step 6 on page 15.

6 Turn on the fan if desired.

See step 7 on page 15.

7 When you are finished exercising, remove the key from the console.

See step 8 on page 15.

THE INFORMATION MODE

The console features an information mode that keeps track of treadmill usage information. The information mode also allows you to select miles or kilometers as the unit of measurement and to turn on and turn off the demo mode.

When the information mode is selected, you can also choose an audio setting for your cross training workouts.

To select the information mode, hold down the Stop button, insert the key into the console, and then release the Stop button. When the information mode is selected, the following information will appear in the display:

The lower right part of the display will show the total number of miles or kilometers that the walking belt has moved. The lower left part of the display will show the total number of hours that the treadmill has been operated. In addition, the word "ENGLISH" for miles or the word "METRIC" for kilometers will appear in the upper left part of the display. To change the unit of measurement, press the Speed increase button.

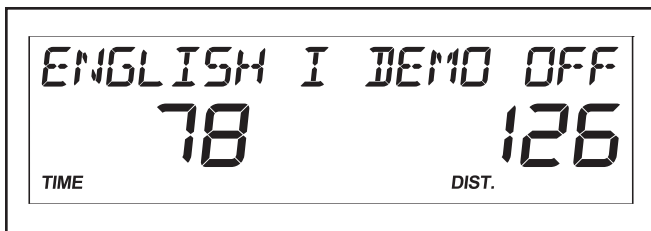

When you use a cross training program, a personal trainer can guide you through your workouts; you can select any of three audio settings while the information mode is selected. In the center of the upper part of the display, an "I" (for Instruction), an "N" (for No), or a "Y" (for Yes) will appear. When "I" is selected, the voice of a personal trainer will guide you through your workouts and give detailed instructions. When "N" is selected, you will not hear the voice of the personal trainer. When "Y" is selected, the voice of the personal trainer will guide you through your workouts but will not give detailed instructions. Press the Incline decrease button to change the audio setting if desired.

IMPORTANT: If the words "DEMO ON" appear in the display, the console is in the "demo" mode. This mode is intended to be used only when a treadmill is displayed in a store. When the console is in the demo mode, the power cord can be plugged in, the key can be removed from the console, and the indicators in the display will automatically appear in a preset sequence; the buttons on the console will not operate. **If "DEMO ON" appears when the information mode is selected, press the Speed decrease button so that "DEMO OFF" appears.**

To exit the information mode, remove the key from the console.

THE OPTIONAL CHEST PULSE SENSOR

An optional chest pulse sensor offers hands-free operation as it tracks your heart rate during your workouts. **To purchase the optional chest pulse sensor, call the toll-free telephone number on the front cover of this manual.**

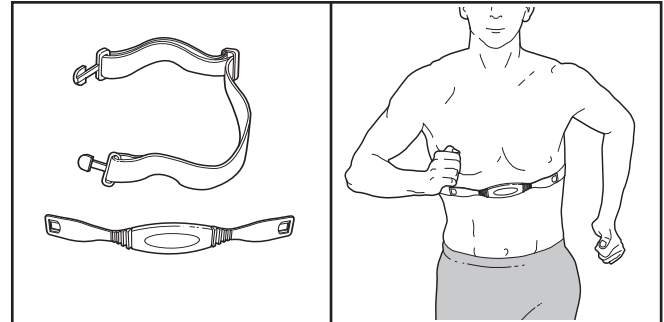

If you purchase the optional chest pulse sensor, follow the steps below to install the receiver included with the chest pulse sensor.

1. **Make sure that the key is removed from the console and that the power cord is unplugged.**

Remove the indicated Console Screw (4) and the Access Door (73) from the back of the Console (91).

2. Connect the wire on the receiver (A) to the indicated wire extending from the Console (91). **Hold the receiver so the small cylinder is oriented as shown and is facing the Console Back.** Attach the receiver to the plastic posts on the Access Door (73) with the two included small screws.
3. **Make sure that no wires are pinched.** Reattach the Access Door (73) with the Console Screw (4). Discard the other wires included with the receiver.

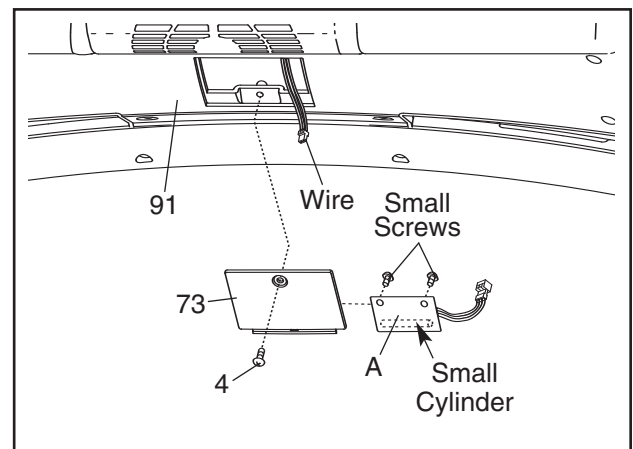

HOW TO FOLD AND MOVE THE TREADMILL

HOW TO FOLD THE TREADMILL FOR STORAGE

Before folding the treadmill, adjust the incline to the lowest position. If you do not do this, you may damage the treadmill when you fold it. Next, unplug the power cord. **CAUTION:** You must be able to safely lift 45 lbs. (20 kg) to raise, lower, or move the treadmill.

1. Hold the metal frame firmly in the location shown by the arrow at the right. **CAUTION:** To decrease the possibility of injury, do not lift the frame by the plastic foot rails. Bend your legs and keep your back straight as you raise the frame—do not lift with your back. Raise the frame about halfway to the vertical position.

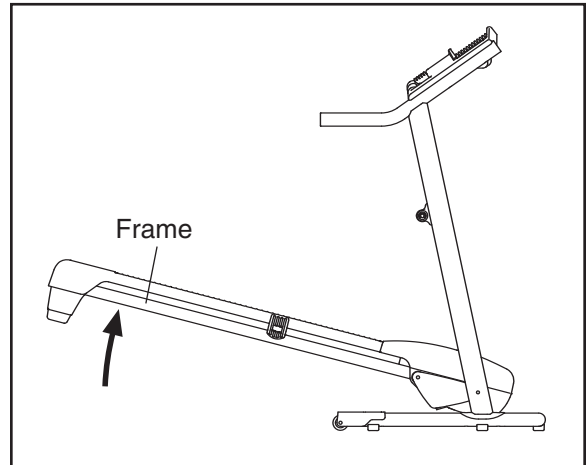

2. Move your right hand to the position shown and hold the treadmill firmly. Using your left hand, pull the latch knob to the left and hold it. Raise the frame until the catch is past the latch pin. Then, slowly release the latch knob; make sure that the catch is resting against the latch pin.

To protect the floor or carpet from damage, place a mat under the treadmill. Keep the treadmill out of direct sunlight. Do not leave the treadmill in the storage position in temperatures above 85°F (30°C).

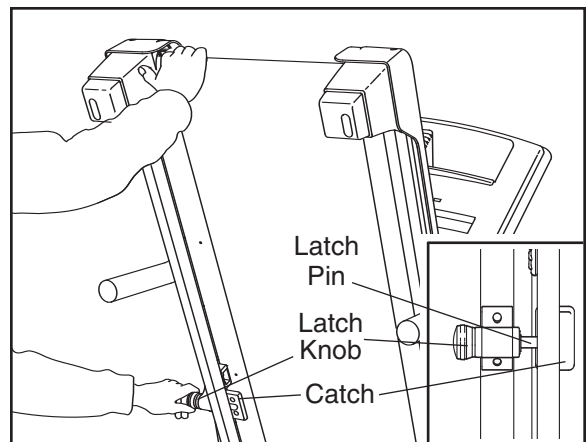

HOW TO MOVE THE TREADMILL

Before moving the treadmill, convert the treadmill to the storage position as described above. **Make sure that the catch is resting against the latch pin.**

1. Hold the handrails and place one foot against one of the wheels. **Do not pull back on the frame.**
2. Tilt the treadmill backward until it rolls freely on the wheels, and carefully move the treadmill to the desired location. **Never move the treadmill without tipping it backward. To reduce the risk of injury, use extreme caution while moving the treadmill. Do not attempt to move the treadmill over an uneven surface.**
3. Place one foot against one of the wheels, and carefully lower the treadmill until it is in the storage position.

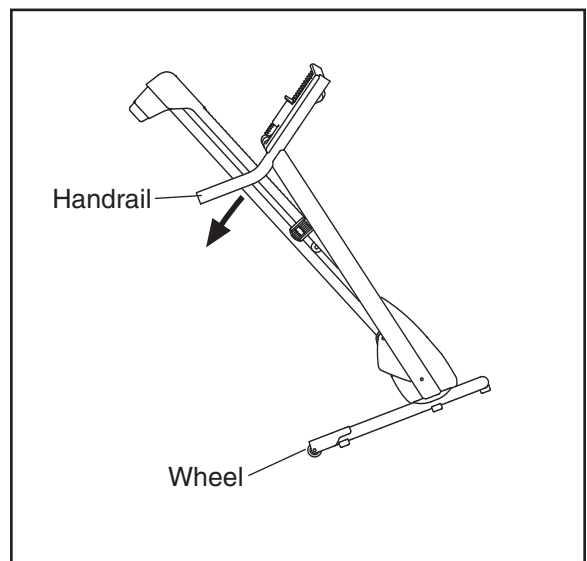

HOW TO LOWER THE TREADMILL FOR USE

1. Hold the upper end of the treadmill with your right hand as shown. Using your left hand, pull the latch knob to the left and hold it. Next, lower the frame until it is past the latch pin. Then, release the latch knob.

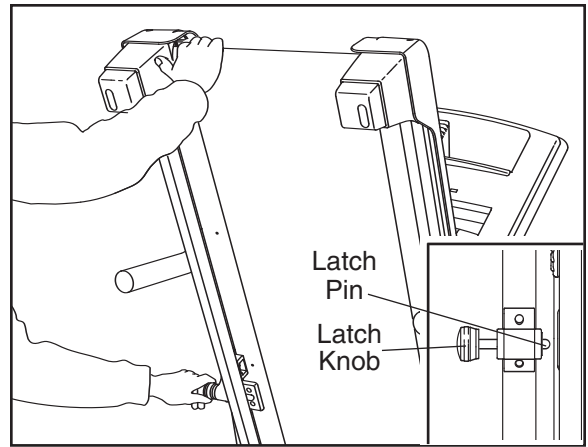

2. Hold the frame firmly with both hands, and lower it to the floor. **To decrease the possibility of injury, bend your legs and keep your back straight.**

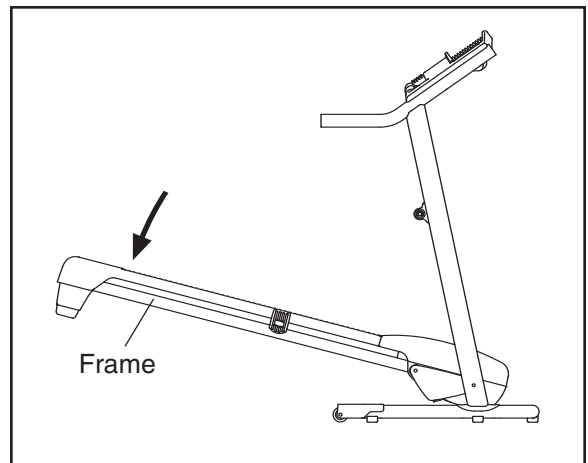

MAINTENANCE AND TROUBLESHOOTING

Most treadmill problems can be solved by following the steps below. Find the symptom that applies, and follow the steps listed. If further assistance is needed, please see the front cover of this manual.

PROBLEM: The power does not turn on

SOLUTION: a. Make sure that the power cord is plugged into a surge suppressor, and that the surge suppressor is plugged into a properly grounded outlet (see page 12). Use only a single-outlet surge suppressor that meets all of the specifications described on page 12. Important: The treadmill is not compatible with GFCI-equipped outlets.

b. After the power cord has been plugged in, make sure that the key is inserted into the console.

c. Check the reset/off circuit breaker located on the treadmill frame near the power cord. If the switch protrudes as shown, the circuit breaker has tripped. To reset the circuit breaker, wait for five minutes, and then press the switch back in.

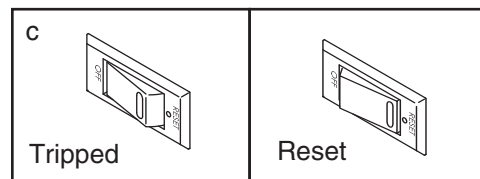

PROBLEM: The power turns off during use

SOLUTION: a. Check the reset/off circuit breaker (see the drawing above). If the circuit breaker has tripped, wait for five minutes and then press the switch back in.

b. Make sure that the power cord is plugged in.

c. Remove the key from the console. Reinsert the key into the console.

d. If the treadmill still will not run, please see the front cover of this manual.

PROBLEM: The displays of the console do not function properly

SOLUTION: a. Remove the key from the console and **UNPLUG THE POWER CORD**. Remove the three indicated Hood Screws (20) and two Foot Rail Screws (25). Then, carefully remove the Hood (65).

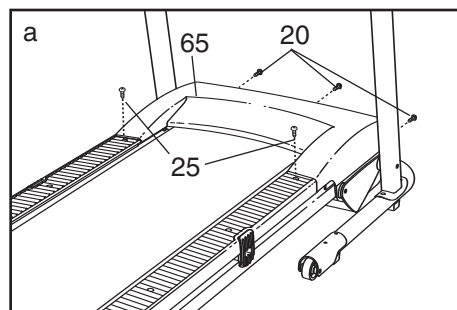

Locate the Reed Switch (89) and the Magnet (62) on the left side of the Pulley (71). Turn the Pulley until the Magnet is aligned with the Reed Switch. **Make sure that the gap between the Magnet and the Reed Switch is about 1/8"**. If necessary, loosen the Screw (3), move the Reed Switch slightly, and then retighten the Screw. Reattach the Hood (not shown), and run the treadmill for a few minutes to check for a correct speed reading.

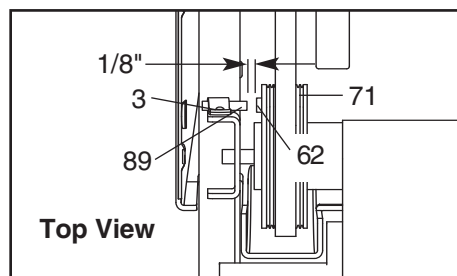

PROBLEM: The walking belt slows when walked on

SOLUTION: a. Use only a single-outlet surge suppressor that meets all of the specifications described on page 12.

b. If the walking belt is overtightened, treadmill performance may decrease and the walking belt may become damaged. Remove the key and **UNPLUG THE POWER CORD**. Using the hex key, turn both rear roller bolts counterclockwise, 1/4 of a turn. When the walking belt is properly tightened, you should be able to lift each edge of the walking belt 2 to 3 inches off the walking platform. Be careful to keep the walking belt centered. Then, plug in the power cord, insert the key, and run the treadmill for a few minutes. Repeat until the walking belt is properly tightened.

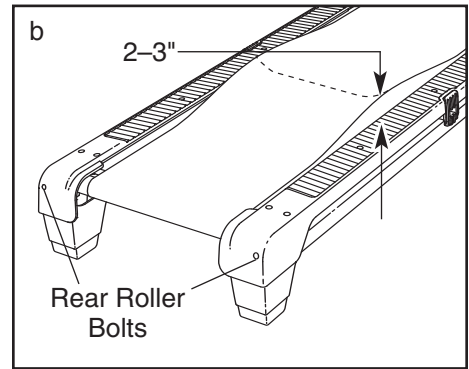

c. If the walking belt still slows when walked on, please see the front cover of this manual.

PROBLEM: The walking belt is off-center or slips when walked on

SOLUTION: a. **If the walking belt has shifted to the left**, first remove the key and **UNPLUG THE POWER CORD**. Using the hex key, turn the left rear roller bolt clockwise 1/2 of a turn. Be careful not to overtighten the walking belt. **If the walking belt has shifted to the right**, turn the left rear roller bolt counterclockwise 1/2 of a turn. Then, plug in the power cord, insert the key, and run the treadmill for a few minutes. Repeat until the walking belt is centered.

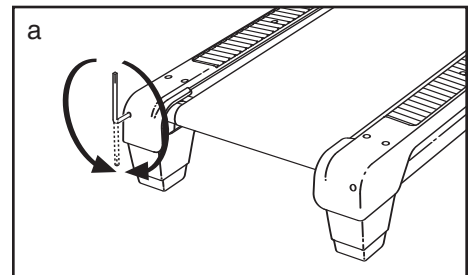

b. **If the walking belt slips when walked on**, first remove the key and **UNPLUG THE POWER CORD**. Using the hex key, turn both rear roller bolts clockwise, 1/4 of a turn. When the walking belt is correctly tightened, you should be able to lift each edge of the walking belt 2 to 3 inches off the walking platform. Be careful to keep the walking belt centered. Then, plug in the power cord, insert the key, and carefully walk on the treadmill for a few minutes. Repeat until the walking belt is properly tightened.

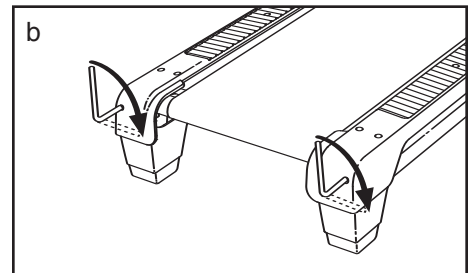

CONDITIONING GUIDELINES

⚠️ WARNING: Before beginning this or any exercise program, consult your physician. This is especially important for individuals over the age of 35 or individuals with pre-existing health problems.

The pulse sensor is not a medical device. Various factors, including your movement, may affect the accuracy of heart rate readings. The sensor is intended only as an exercise aid in determining heart rate trends in general.

The following guidelines will help you to plan your exercise program. For more detailed exercise information, obtain a reputable book or consult your physician.

EXERCISE INTENSITY

Whether your goal is to burn fat or to strengthen your cardiovascular system, the key to achieving the desired results is to exercise with the proper intensity. The proper intensity level can be found by using your heart rate as a guide. The chart below shows recommended heart rates for fat burning and aerobic exercise.

165	155	145	140	130	125	115	♥
145	138	130	125	118	110	103	♥
125	120	115	110	105	95	90	♥
20	30	40	50	60	70	80	

To find the proper heart rate for you, first find your age near the bottom of the chart (ages are rounded off to the nearest ten years). Next, find the three numbers above your age. The three numbers define your “training zone.” The lower two numbers are recommended heart rates for fat burning; the higher number is the recommended heart rate for aerobic exercise.

To measure your heart rate during exercise, use the pulse sensor on the console.

Fat Burning

To burn fat effectively, you must exercise at a relatively low intensity level for a sustained period of time. During the first few minutes of exercise, your body

uses easily accessible *carbohydrate calories* for energy. Only after the first few minutes does your body begin to use stored *fat calories* for energy. If your goal is to burn fat, adjust the speed and incline of the treadmill until your heart rate is near the lowest number in your training zone.

For maximum fat burning, adjust the speed and incline of the treadmill until your heart rate is near the middle number in your training zone.

Aerobic Exercise

If your goal is to strengthen your cardiovascular system, your exercise must be “aerobic.” Aerobic exercise is activity that requires large amounts of oxygen for prolonged periods of time. This increases the demand on the heart to pump blood to the muscles, and on the lungs to oxygenate the blood. For aerobic exercise, adjust the speed and incline of the treadmill until your heart rate is near the highest number in your training zone.

WORKOUT GUIDELINES

Each workout should include the following three parts:

A Warm-up—Start each workout with 5 to 10 minutes of stretching and light exercise. A proper warm-up increases your body temperature, heart rate and circulation in preparation for exercise.

Training Zone Exercise—After warming up, increase the intensity of your exercise until your pulse is in your training zone for 20 to 60 minutes. (During the first few weeks of your exercise program, do not keep your pulse in your training zone for longer than 20 minutes.) Breathe regularly and deeply as you exercise—never hold your breath.

A Cool-down—Finish each workout with 5 to 10 minutes of stretching to cool down. This will increase the flexibility of your muscles and will help prevent post-exercise problems.

EXERCISE FREQUENCY

To maintain or improve your condition, complete three workouts each week, with at least one day of rest between workouts. After a few months, you may complete up to five workouts each week if desired. The key to success is to make exercise a regular and enjoyable part of your everyday life.

SUGGESTED STRETCHES

The correct form for several basic stretches is shown at the right. Move slowly as you stretch—never bounce.

1. Toe Touch Stretch

Stand with your knees bent slightly and slowly bend forward from your hips. Allow your back and shoulders to relax as you reach down toward your toes as far as possible. Hold for 15 counts, then relax. Repeat 3 times. Stretches: Hamstrings, back of knees and back.

2. Hamstring Stretch

Sit with one leg extended. Bring the sole of the opposite foot toward you and rest it against the inner thigh of your extended leg. Reach toward your toes as far as possible. Hold for 15 counts, then relax. Repeat 3 times for each leg. Stretches: Hamstrings, lower back and groin.

3. Calf/Achilles Stretch

With one leg in front of the other, reach forward and place your hands against a wall. Keep your back leg straight and your back foot flat on the floor. Bend your front leg, lean forward and move your hips toward the wall. Hold for 15 counts, then relax. Repeat 3 times for each leg. To cause further stretching of the achilles tendons, bend your back leg as well. Stretches: Calves, achilles tendons and ankles.

4. Quadriceps Stretch

With one hand against a wall for balance, reach back and grasp one foot with your other hand. Bring your heel as close to your buttocks as possible. Hold for 15 counts, then relax. Repeat 3 times for each leg. Stretches: Quadriceps and hip muscles.

5. Inner Thigh Stretch

Sit with the soles of your feet together and your knees outward. Pull your feet toward your groin area as far as possible. Hold for 15 counts, then relax. Repeat 3 times. Stretches: Quadriceps and hip muscles.

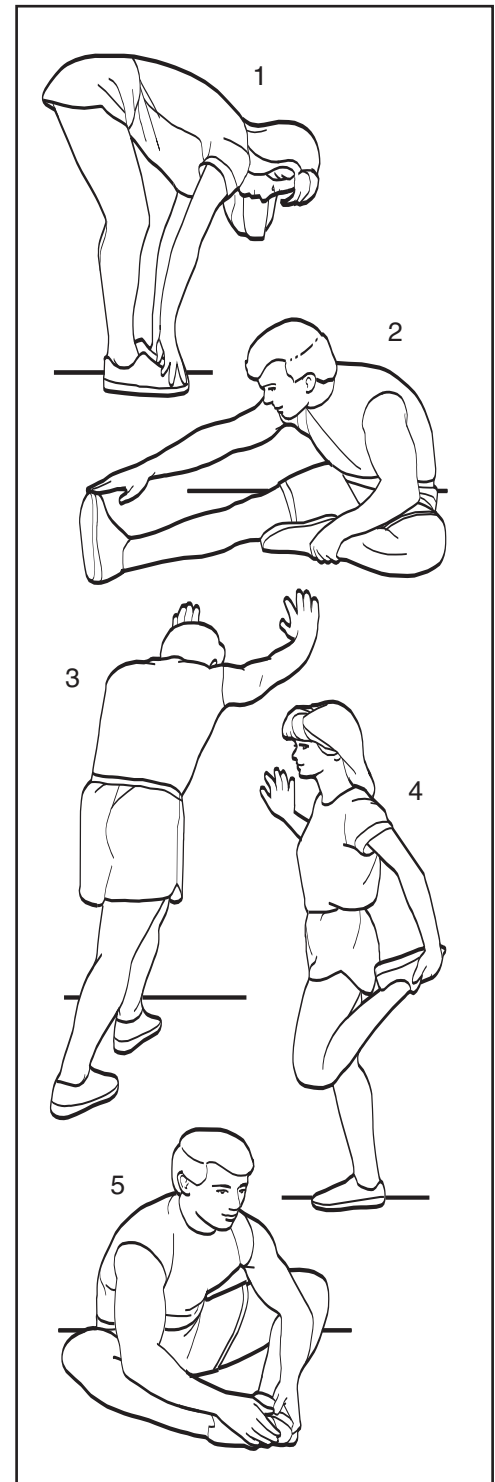

PART LIST—Model No. PFTL54706.0

R1006A

To locate the parts listed below, see the EXPLODED DRAWING on pages 28 to 31.

Key No.	Qty.	Description	Key No.	Qty.	Description	Key No.	Qty.	Description
1	2	Colored Patch	36	2	Rear Roller Star	76	1	Walking Belt
		Frame Bolt			Washer	77	4	Handrail Endcap
2	6	Upright Bolt/ Lift Frame Bolt	37	1	Reset/Off Circuit Breaker	78	2	Platform Cushion
3	2	Tie Screw/Reed Switch Screw	38	2	Motor Star Washer	79	1	Drive Motor
4	13	Console Back Screw	39	1	Wire Harness	80	2	Wire Tie
5	6	Handrail Star Washer	40	1	Incline Motor	81	12	8" Tie
6	1	Latch Warning Decal	41	4	Screw	82	1	Incline Motor Nut, Upper
7	2	Crossbar Star Washer	42	4	Electronics Star Washer	83	1	Reed Switch Clip
8	6	Handrail Bolt	43	4	Wheel Housing Nut	84	3	Ground Screw/ Controller Screw
9	6	Upright Star Washer	44	6	Motor TensionNut/ Platform Nut	85	2	Crossbar Screw
10	16	Console Screw/ Latch Screw	45	2	Wheel Housing	86	1	Walking Platform
11	4	Frame Spacer	46	1	Motor Pivot Nut	87	1	Controller
12	1	Console Back	47	3	Hood Clip	88	1	Console Crossbar
13	4	Wheel Housing Bolt	48	1	Latch Housing	89	1	Reed Switch
14	2	Upright Washer	49	2	Grommet	90	1	Power Cord
15	1	Key/Clip	50	2	Isolator Fastener	91	1	Console Assembly
16	8	Nut	51	1	Frame	92	1	Incline Motor Nut, Lower
17	1	6 mm Hex Key	52	1	Base	93	2	Belt Guide
18	1	4 mm Hex Key	53	1	Left Upright	94	1	5 mm Hex Key
19	4	Bracket Screw/ Platform Screw	54	1	Right Upright	95	2	Frame Endcap
20	3	Belly Pan Screw	55	1	Rear Roller	96	1	Releasable Tie
21	6	Screw	56	1	Motor Belt	97	1	Rear Foot, Right
22	1	Left Handrail	57	1	Electronics Bracket	98	1	Filter Wire
23	1	Lift Frame	58	1	Incline Motor	99	1	Power Cord Grommet
24	1	Latch Pin Assembly	59	1	Bolt, Upper	100	1	Incline Motor Wire
25	6	Foot Rail Screw	60	1	Motor Bracket	101	2	Front Roller Washer
26	6	Base Pad Screw	61	1	Left Rear Roller Bracket	102	1	M4 Screw
27	2	Rear Roller Bracket Screw	62	1	Right Rear Roller Bracket	103	1	Console Fan
28	4	Belt Guide Screw	63	6	Magnet	104	2	Hand Weight
29	2	Rear Roller Adj. Bolt	64	1	Base Pad	105	6	Cage Nut
30	2	Motor Bolt	65	1	Latch Catch	106	2	Caution Decal
31	1	Motor Pivot Bolt	66	1	Hood	#	1	6" Red Wire, M/F
32	4	Wheel Housing Washer	67	1	Belly Pan	#	1	8" Black Wire, M/F
33	1	Right Handrail	68	1	Left Foot Rail	#	1	4" Blue Wire, 2F
34	2	Motor Tension Bolt	69	1	Right Foot Rail	#	1	16" Blue Wire, 2F
35	2	Wheel Bolt	70	1	Wheel Spacer	#	1	4" White Wire, M/F
			71	2	Wheel	#	1	4" Black Wire, M/F
			72	1	Front Roller/Pulley			User's Manual
			73	1	Incline Motor Bolt, Lower			
			74	1	Access Door			
			75	4	Rear Foot, Left			
					Long Foot			
					Rail Screw			

These parts are not illustrated.
Specifications are subject to change
without notice.

EXPLODED DRAWING A—Model No. PFTL54706.0

R1006A

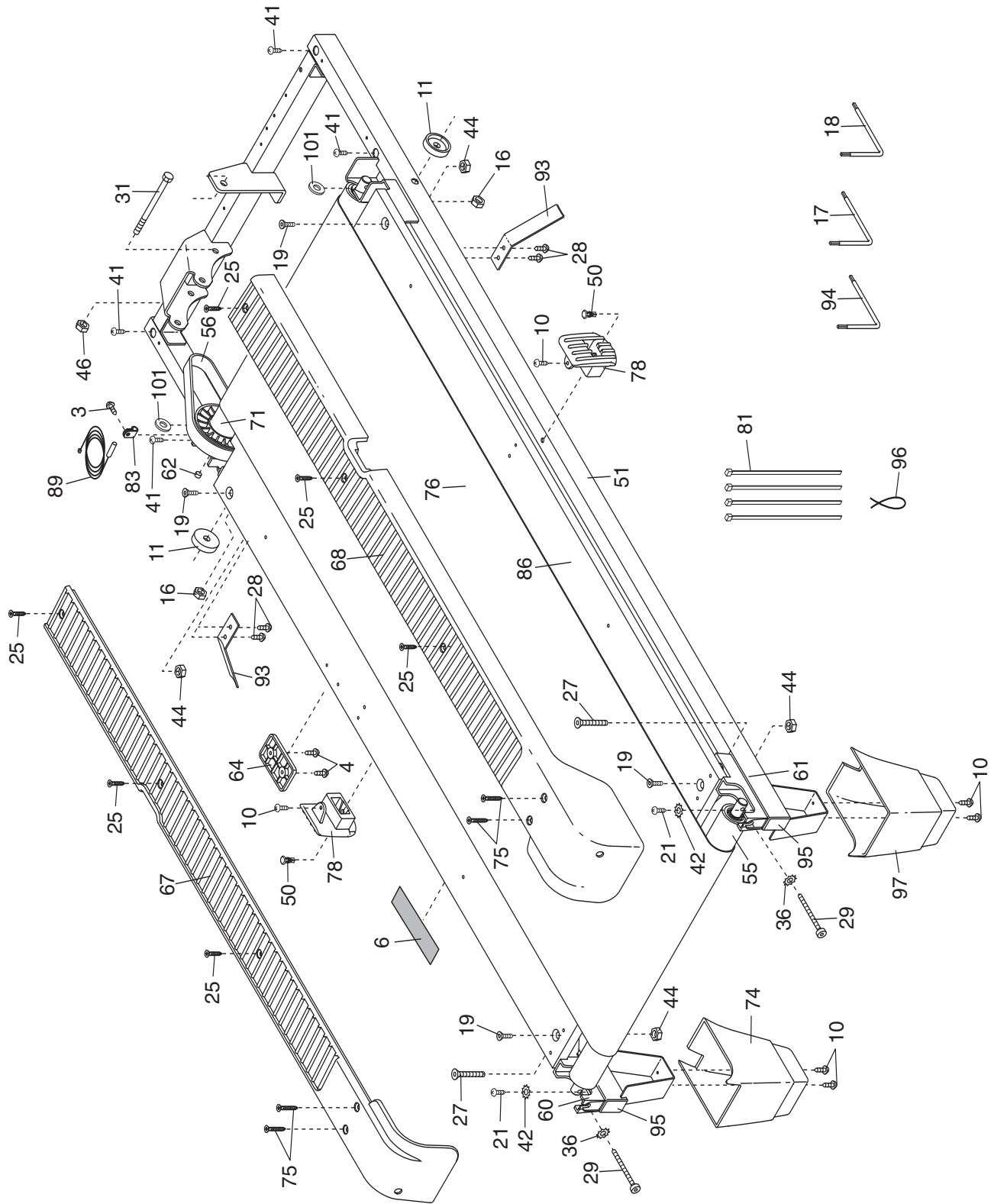

EXPLODED DRAWING B—Model No. PFTL54706.0

R1006A

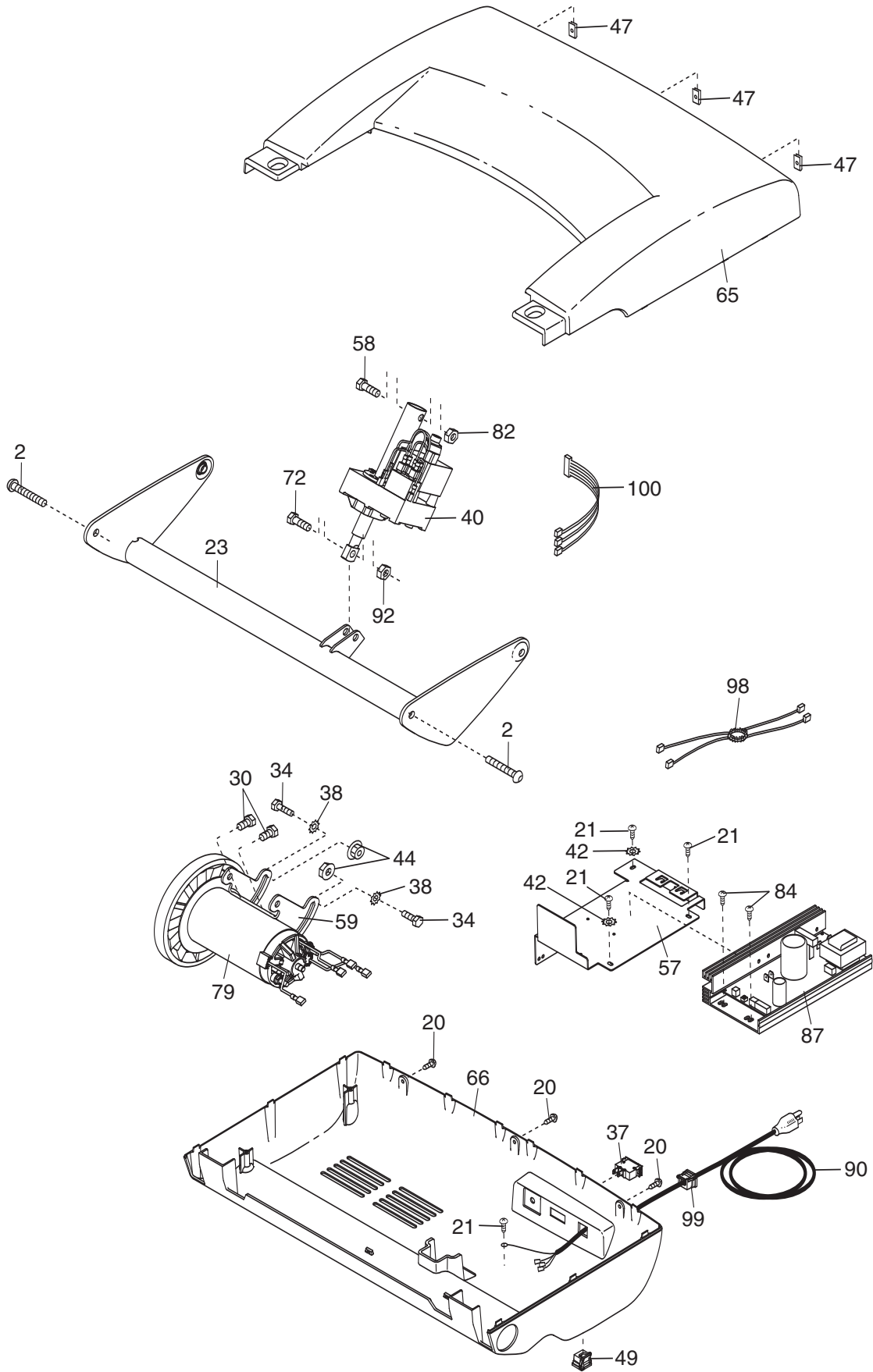

EXPLODED DRAWING C—Model No. PFTL54706.0

R1006A

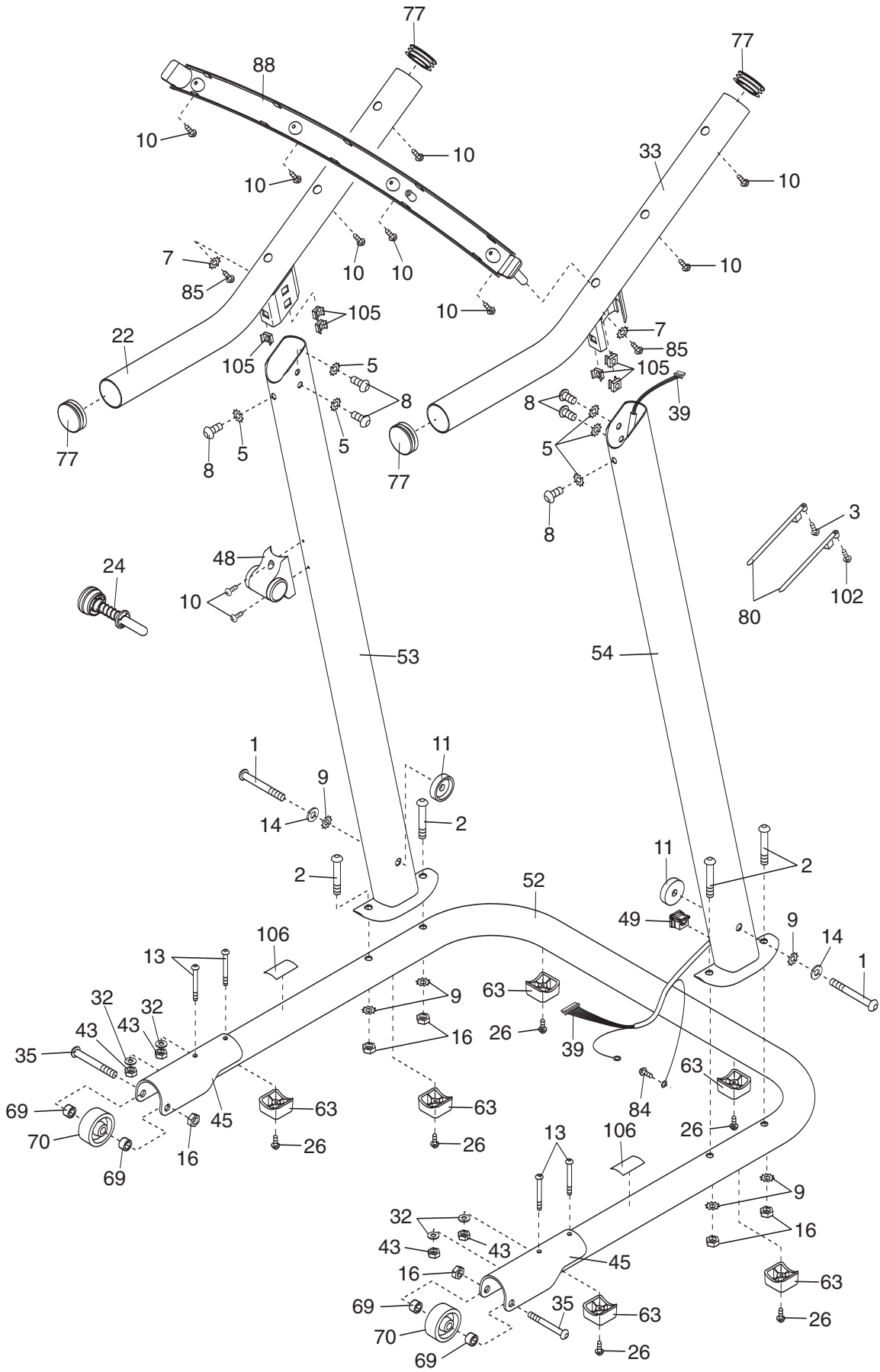

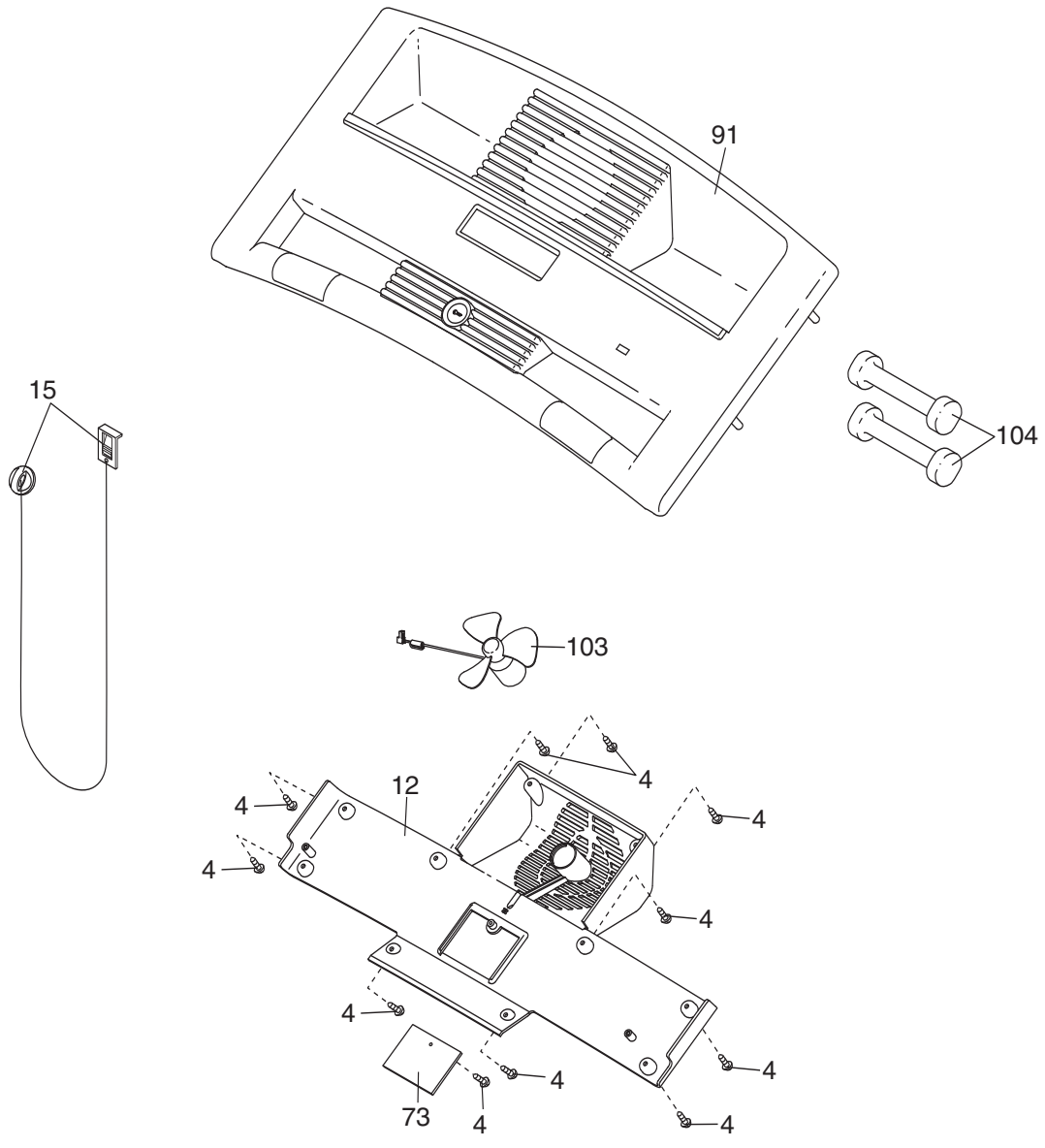

ORDERING REPLACEMENT PARTS

To order replacement parts, please see the front cover of this manual. To help us assist you, be prepared to provide the following information when calling:

- the MODEL NUMBER of the product (PFTL54706.0)
- the NAME of the product (PROFORM 575 CROSSTRAINER treadmill)
- the SERIAL NUMBER of the product (see the front cover of this manual)
- the KEY NUMBER and DESCRIPTION of the desired part(s) (see the PART LIST and the EXPLODED DRAWING on pages 27 to 31)

LIMITED WARRANTY

ICON Health & Fitness, Inc. (ICON) warrants this product to be free from defects in workmanship and material under normal use and service conditions. The drive motor is warranted for ten (10) years after the date of purchase. Parts and labor are warranted for ninety (90) days after the date of purchase.

This warranty extends only to the original purchaser. ICON's obligation under this warranty is limited to replacing or repairing, at ICON's option, the product through one of its authorized service centers. All repairs for which warranty claims are made must be pre-authorized by ICON. If the product is shipped to a service center, freight charges to and from the service center will be the customer's responsibility. For in-home service, the customer will be responsible for a minimal trip charge. This warranty does not extend to any product or damage to a product caused by or attributable to freight damage, abuse, misuse, improper or abnormal usage or repairs not provided by an ICON authorized service center; products used for commercial or rental purposes; or products used as store display models. No other warranty beyond that specifically set forth above is authorized by ICON.

ICON is not responsible or liable for indirect, special or consequential damages arising out of or in connection with the use or performance of the product or damages with respect to any economic loss, loss of property, loss of revenues or profits, loss of enjoyment or use, costs of removal or installation or other consequential damages of whatsoever nature. Some states do not allow the exclusion or limitation of incidental or consequential damages. Accordingly, the above limitation may not apply to you.

The warranty extended hereunder is in lieu of any and all other warranties and any implied warranties of merchantability or fitness for a particular purpose is limited in its scope and duration to the terms set forth herein. Some states do not allow limitations on how long an implied warranty lasts. Accordingly, the above limitation may not apply to you.

This warranty gives you specific legal rights. You may also have other rights which vary from state to state.

ICON HEALTH & FITNESS, INC., 1500 S. 1000 W., LOGAN, UT 84321-9813