

Product Owner's Manual

Commercial Products

Treadmills:

- 932i
- 954i

Ellipticals:

- EFX534i
- EFX532i

Cycle:

- 842i



Important Safety Instructions

When using Precor equipment, always take basic precautions, including the following:

- Read all instructions before using the equipment. These instructions are written to educate patrons and other users in the proper use of the equipment.
- Other sections in this manual provide more details of safety features. Be sure to read these sections and observe all safety notices.
- Before beginning any fitness program, make sure all users see a physician for a complete physical examination.

Il est conseillé de subir un examen médical complet avant d'entreprendre tout programme d'exercice. Si vous avez des étourdissements ou des faiblesses, arrêtez les exercices immédiatement.

DANGER Before cleaning it, always unplug the equipment from its power source to reduce the risk of electric shock. Before cleaning self-powered equipment, disconnect the optional power adapter.

WARNING To reduce the risk of burns, fire, electric shock, or injury, take the following precautions:

- Do not allow children or people unfamiliar with its operation on or near the equipment. Do not leave children unsupervised around the equipment.
- Never leave the equipment unattended when it is plugged in. Unplug the equipment from the power source when it is not in use, before cleaning it, and before providing authorized service.
Note: The optional power adapter is considered an electrical power source for self-powered equipment.
- Keep all electrical components away from liquids to prevent shock.
- Assemble and operate the equipment on a solid, level surface. Locate the equipment a few feet from walls or furniture.
- Maintain the equipment in good working condition. Refer to *Maintenance*.
- If you plan to move the equipment, obtain help and use proper lifting techniques. For more information, refer to *Moving the Equipment*.
- Use the equipment only for its intended purpose as described in this manual. Do not use accessory attachments that are not recommended by the manufacturer, as such attachments may cause injuries.

- Never operate the equipment if it is damaged, not working properly, when it has been dropped, or has been immersed in water. Return the equipment to a service center for examination and repair.
- Keep the power cord or optional power adapter and plug away from heated surfaces.
- Do not operate the equipment where aerosol (spray) products are being used or where oxygen is being administered.
- Do not use outdoors.
- Do not attempt to service the equipment yourself except to follow the maintenance instructions found in this manual.
- Never drop or insert objects into any opening. Keep hands away from moving parts.
- Do not set anything on the stationary handrails or handlebars, display console, or covers. Place liquids, magazines, and books in the appropriate receptacles.

Safety Code

The club owner or manager has the option to enable the safety code. The code involves entering four number keys in sequence. If the correct keys are not pressed within two minutes, further user access is denied. For more information, refer to *Treadmill Safety Features* and *Club Features*.

Safety Approval

When identified with the ETL-c logo, the equipment has been tested and conforms to the requirements of CAN/CSA-E-335-1/3-04, EN 60335-1: 2002 Safety of Household and Similar Electrical Appliances. This equipment is a Class S/B or C certified machine according to applicable EN957 standards.

Educating Users

Take time to educate users on the safety instructions found in both the *User's Reference Manual* and *Product Owner's Manual*.

Explain to your club or facility patrons that they should:

- Hold onto a stationary handrail or handlebar while stepping onto the equipment or when getting comfortably seated on the cycle.
- Face the display at all times.
- Hold on to a stationary handrail or handlebar with one hand whenever reaching with the other hand to touch the display keys.
- On treadmills: straddle the running belt and attach the safety clip to clothing at waist level before touching the display.

Important: For safety, make sure users step onto the running belt while it is moving at or below 1 mile per hour (1 kilometer per hour).

Hazardous Materials and Proper Disposal

The self-powered equipment has an internal battery which contains materials that are considered hazardous to the environment. Proper disposal of the battery is required by federal law.

If you plan to dispose of your equipment, contact Precor Commercial Products Customer Support for information regarding battery removal. Refer to *Obtaining Service*.

Product Recycling and Disposal

This equipment must be recycled or discarded according to applicable local and national regulations.

Product labels, in accordance with European Directive 2002/96/EC concerning waste electrical and electronic equipment (WEEE), determine the framework for the return and recycling of used equipment as applicable throughout the European Union. The WEEE label indicates that the product is not to be thrown away, but rather reclaimed upon end of life per this Directive.

In accordance with the European WEEE Directive, electrical and electronic equipment (EEE) is to be collected separately and to be reused, recycled, or recovered at end of life. Users of EEE with the WEEE label per Annex IV of the WEEE Directive must not dispose of end of life EEE as unsorted municipal waste, but use the collection framework available to customers for the return, recycling, and recovery of WEEE. Customer participation is important to minimize any potential effects of EEE on the environment and human health due to the potential presence of hazardous substances in EEE. For proper collection and treatment, refer to *Obtaining Service*.

Radio Frequency Interference (RFI)

Federal Communications Commission, Part 15

This equipment has been tested and found to comply with the limits for a Class A digital device, pursuant to Part 15 of the FCC Rules. These limits are designed to provide reasonable protection against harmful interference in a commercial installation. The equipment generates, uses, and can radiate radio frequency energy and, if not installed and used in accordance with the owner's manual instructions, may cause harmful interference to radio communications.

WARNING *Per FCC rules, changes or modifications not expressly approved by Precor could void the user's authority to operate the equipment.*

Industry Canada

This Class A digital apparatus complies with Canadian ICES-003.

Cet appareil numérique de la classe A est conforme à la norme NMB-003 du Canada.

ATTENTION: Haute Tension
Débranchez avant de réparer

European Applications

This product is compliant to:

- 2004/108/EC Electromagnetic Compatibility Directive.
- 2006/95/EC Low Voltage Directive.
- 2002/95/EC Restriction of Hazardous Substances Directive.

This product conforms to the requirements of the European Council Directive 89/336/EEC, 2004/108/EC Electromagnetic Compatibility and has been tested to the following standards:

- EN55022, Limits & Methods of Measurement of Radio Interference, Information Technology Equipment.
- EN55024, Immunity of Information Technology Equipment.

This product also conforms to the requirements of the European Council Directive 73/23/EEC, 2006/95/EC Low Voltage Directive and has been tested to the following standard:

- IEC 335-1, EN60335-1 Safety of Household and similar Electrical Appliances.

Treadmill Grounding Instructions

The treadmill must be grounded. If the equipment malfunctions or breaks down, grounding provides a path of least resistance for electric current, which reduces the risk of electrical shock. The treadmill has a power cord having an equipment-grounding conductor and a grounding plug. The plug must be inserted into an outlet that is properly installed and grounded in accordance with all local codes and ordinances. Failure to properly ground the treadmill could void the Precor Limited Warranty.

DANGER Improper connection of the equipment-grounding conductor can result in a risk of electric shock. Check with a qualified electrician or service person if you are in doubt as to whether the equipment is properly grounded. Do not modify the plug provided with the treadmill. If it does not fit the outlet, get a proper outlet installed by a qualified electrician.

120 V and 240 V Equipment Designated for U.S. Markets

The treadmill must be connected to a dedicated, grounded circuit. A 20-amp dedicated circuit is recommended. The equipment's grounding plug looks like the plug shown in one of the following figures. The power outlet must have the same configuration as the plug. No adapter should be used with this product.

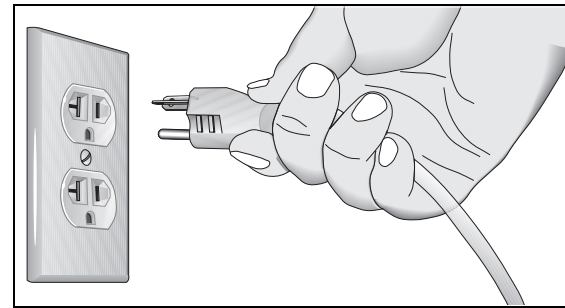

Figure 1: 120-volt power plug

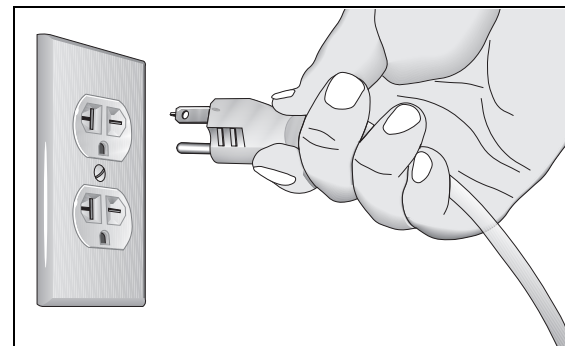

Figure 2: 240-volt power plug

Obtaining Service

You should not attempt to service the equipment except for maintenance tasks described in this manual. For information about product operation or service, see the Precor web site at www.precor.com. Should you need more information regarding customer support numbers or a list of Precor authorized service centers, visit the Precor web site at www.precor.com/corp/contact.

For future reference, write the model, serial number, and date of purchase for all your equipment in the space provided. The serial number is printed on a label located near the power cord connection (treadmills) or receptacle (self-powered equipment).

Model #: _____	Base Serial #: _____
	Display Serial #: _____
	Date purchased: _____
Model #: _____	Base Serial #: _____
	Display Serial #: _____
	Date purchased: _____
Model #: _____	Base Serial #: _____
	Display Serial #: _____
	Date purchased: _____
Model #: _____	Base Serial #: _____
	Display Serial #: _____
	Date purchased: _____

Table of Contents

Important Safety Instructions.....	1	Choosing a Language.....	19
Safety Code.....	2	Selecting a U.S. Standard or Metric Display.....	20
Safety Approval	2	Setting an Exercise Session Time Limit.....	20
Educating Users	3	Setting a Pause Time Limit.....	21
Hazardous Materials and Proper Disposal.....	3	Setting a Cool-Down Time Limit	21
Product Recycling and Disposal	3	Treadmill: Determining the Club Speed Limit	22
Radio Frequency Interference (RFI).....	4	Treadmill: Setting an Incline Limit	22
European Applications.....	4	Treadmill: Accessing Performance Programs.....	23
Treadmill Grounding Instructions	5	Treadmill: Changing Remote Control Access.....	23
Obtaining Service	6	EFX: Changing the Auto-Level Setting.....	24
Treadmill Safety Features	8	Cycle: Setting a Resistance Range.....	24
Entering the Safety Code.....	8	Informational Displays	26
Using the Safety Clip.....	8	User ID Entry with CSAFE Equipment.....	29
Turning the Treadmill On and Off.....	9	Maintenance.....	30
Weight Limit	9	Daily Inspection	30
Location	9	Daily Cleaning.....	30
Self-Powered Features.....	10	EFX: Cleaning the Ramp.....	31
Informational Displays Prior to Shutdown.....	10	Storing the Chest Strap.....	31
Symptoms of a Low Battery.....	11	Treadmill: Checking the Alignment of the	
Using the Optional Power Adapter.....	11	Running Belt	32
The Optional Power Adapter Kit.....	12	Treadmill: Adjusting the Running Belt.....	33
Replacing the Battery.....	12	Upright Cycle: Adjusting the Seat Tilt.....	34
Club Features.....	13	Recumbent Cycle: Realigning the Seat.....	35
Club Programming Tips.....	14	Moving the Equipment.....	36
Accessing Club Programming Mode and		Long-Term Storage	36
Changing the Settings	16	Precor Commercial Equipment	
Treadmill: Selecting Safety Code Protection.....	19	Limited Warranty.....	37

Treadmill Safety Features

Before allowing users on Precor equipment, review the *Important Safety Instructions* found at the beginning of this manual. You should also teach your patrons how to safely use the equipment following the guidelines in *Educating Users*.

Entering the Safety Code

When the equipment is shipped from the factory, the safety code protection feature is disabled. If you wish to enable the safety code, refer to *Club Features*. Inform users that the equipment requests a safety code to help prevent unauthorized use. When users select a program or press QUICKSTART at the PRECOR banner, the following prompt appears:

ENTER SAFETY CODE

Users have two minutes to press the following number key sequence and continue their workout: 1, 2, 3, 4.

Important: Tell users to hold onto the handrail with one hand before entering the safety code with the other hand.

If the correct keys are pressed, the program selection process begins. If the code is incorrect, the display prompts the user to reenter the code after a 2-minute time out.

Note: On the treadmill, a 3-second countdown appears on the display, and then the running belt starts moving. Refer to *Workout Options* in the *User's Reference Manual*.

Using the Safety Clip

Instruct users how important it is to use the safety clip while exercising on the treadmill. Instruct them on how to attach it to their clothing near their waistline. If any complications occur, a strong tug on the safety lanyard will stop the running belt.

If the safety switch trips while users are exercising, have them reattach the safety clip, press the SPEED up key or QUICKSTART and reenter the safety code, if necessary.

Note: The treadmill retains users' workout statistics if they resume their workout within the limit set for pause mode.

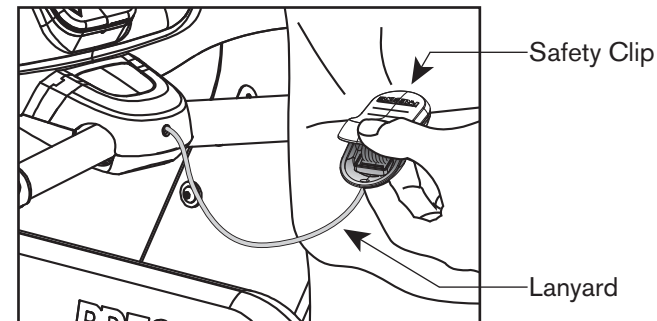

Figure 3: Attaching the safety clip

Turning the Treadmill On and Off

To turn the treadmill On and Off, use the power switch located beneath the hood, near the power cord receptacle.

Important: When it is not being used, turn the treadmill Off.

Weight Limit

You should not allow runners over 350 lb. (160 kg) or walkers heavier than 500 lb. (225 kg) on the treadmill.

Location

It is important to keep the area around the treadmill open and free from encumbrances such as other equipment. The minimum space requirement needed for user safety and proper maintenance is three feet wide by six feet deep (one meter wide by two meters deep), directly behind the running belt.

Self-Powered Features

On self-powered equipment, the battery initializes and displays the Precor banner when a user starts exercising. A minimum rate of motion must be maintained for the banner to appear, as shown in the following table. When a person meets the requirements, the power that is generated allows the equipment to function properly.

Table 1. Minimum requirements for operation

Equipment	Rate of Motion
EFX	40 strides per minute (SPM)
Cycle	20 revolutions per minute (RPM)

Informational displays appear when the battery is low or when the rate of motion drops below the minimum requirements. The display explains what to do to retain power. If the messages are ignored, the equipment begins shutdown procedures to maintain the charge of the battery. Refer to *Informational Displays Prior to Shutdown*.

An optional power adapter can be purchased and provides sustained power to the equipment. If you plan to change the club settings, the power adapter is highly recommended. To purchase the optional power adapter, check with your dealer. Refer to *Obtaining Service*.

Informational Displays Prior to Shutdown

The equipment saves its battery charge by moving into a shutdown mode. If the user does not maintain the minimum rate of motion, a 30-second shutdown process begins.

Dots appear in the display and all key presses are ignored. If no movement is detected or the rate of motion remains below the minimum, the dots steadily disappear as the countdown continues.

Note: The user can resume exercising if he or she begins before the countdown period elapses.

Important: *If the equipment is connected to a CSAFE master device, a slightly different scenario occurs. When ten seconds remain before the equipment shuts off, the exercise session ends. **RESETTING** appears in the display while the equipment disconnects from the CSAFE master device. All key presses are ignored.*

Symptoms of a Low Battery

If no one has used the equipment for an extended period of time, the battery may need recharging.

Symptoms of a low battery include:

- A flickering or erratic display
- User and program information is lost once the user stops exercising. No workout summary or notification of pending shutdown occurs.

Important: *To maintain a constant power source, use the optional power adapter.*

Using the Optional Power Adapter

After connecting the power adapter to the equipment, plug the opposite end into the appropriate power source 120 V or 240 V.

CAUTION: When the optional power adapter is in use, make sure that the power supply cord does not create a safety hazard. Keep it out of the way of traffic and moving parts. If the power supply cord or power conversion module is damaged, it must be replaced.

The display functions differently when the power adapter is connected. Because the power adapter provides a constant source of power, a user can pause for brief periods without initiating shutdown procedures. When the pause time limit expires and the user has not resumed exercising, the display returns to the Precor banner. Refer to *Setting a Pause Time Limit*. To learn how to install the power adapter, refer to *The Optional Power Adapter Kit*.

The Optional Power Adapter Kit

If you purchase the optional power adapter, you must also purchase the internal cable kit. The kit supplies the cable, bracket, and fasteners that connect the power adapter to the lower electronics board.

CAUTION: The internal cable kit must be installed by authorized service personnel. Do not attempt installation on your own as you could void the Precor Limited Warranty. For more information, refer to *Obtaining Service*.

Once the internal cable kit is installed, you can plug the optional power adapter into the equipment. Plug the opposite end into the appropriate power source for your equipment 120 V or 240 V. Review the safety instructions found at the beginning of this manual before using the power adapter.

Replacing the Battery

The equipment's battery is built to last for a long time. However, if you feel that the battery may need replacing, check with an authorized service technician. Refer to *Obtaining Service*.

CAUTION: The battery stored inside the equipment contains hazardous materials and must be disposed of according to Hazardous Waste Regulations. Refer to *Hazardous Materials and Proper Disposal*.

Club Features

These next few pages explain how to customize the equipment for your club or facility and view useful product information. All these features remain hidden to the patrons and can only be accessed using special key presses. Read this section if you want to:

- Enable or disable the safety code (treadmill)
- Change the display to a different language
- Change the display to show U.S. standard or metric measurements
- Set the maximum exercise and pause times
- Set a cool-down time limit
- Set the maximum speed and incline (treadmill)
- Enable or disable hidden programs or remote access (treadmill)

- Change the auto-level setting (EFX)
- Set the resistance range (cycle)
- View the odometer
- Display the number of hours the equipment has been in use
- View the software versions and part numbers
- Display the serial number
- Check the program usage and error logs

Note: To review the club programming prompts and factory default settings that can be changed through club programming mode, refer to the following table.

Club Programming Tips

- Always start at the Precor banner.
- Electrical power must be supplied. For self-powered equipment, a constant power source is available if you use the optional power adapter, otherwise you will have to maintain the minimum rate of motion. Refer to *Self-Powered Features*. If you plan to program self-powered equipment, purchasing the optional power adapter is highly recommended.

Note: If you do not use the optional power adapter during club programming mode, and the rate of motion falls below the minimum requirements, no warning is given when the equipment moves into its 30-second shutdown procedure.

- The club programming mode is accessed by pressing the RESET key at the Precor banner. The remaining key presses must occur quickly and without pause.
Note: Treadmill keys that can be used interchangeably in club programming mode are: PAUSE/RESET and the red STOP button. On the EFX, the CLEAR and ENTER keys perform specific functions, but the number keypad is disabled once you enter club programming mode.
- The changes made in club programming mode become the default settings whenever the display resets to the Precor banner.

Table 2. Club custom features and settings

Equipment	Club Programming Prompt	Factory Default Setting	Changes you can make
Treadmill	SAFETY CODE	Disabled	An <i>enabled</i> safety code requires a 4-digit entry code before users can access any exercise programs.
All *	SELECT LANGUAGE	English	Several languages affect the display prompts. Choose one.
All *	SELECT UNITS	U.S.	Two standard units of measure affect the display prompts. Choose between U.S. or Metric.
All *	SET MAX WORKOUT TIME	60 minutes	Exercise session time limits range from 1 to 240 minutes. NO LIMIT is accessible beyond 240 minutes.
All *	SET MAX PAUSE TIME	120 seconds	Pause time limits range from 1 to 120 seconds (2 minutes). Restrictions exist for self-powered equipment.
All *	SET COOL DOWN TIME	5 minutes	Cool-down time limits range from 1 to 5 minutes.
Treadmill	SET SPEED LIMIT	Maximum speed available.	Refer to <i>Treadmill: Determining the Club Speed Limit</i> .
Treadmill	SET INCLINE LIMIT	Maximum grade possible.	Refer to <i>Treadmill: Setting an Incline Limit</i> .
Treadmill	HIDDEN PROGRAMS	Hide programs	Two options are available: Show Programs or Hide Programs. Choose one.
Treadmill	REMOTE SPEED CONTROL	Disabled	A computer must be connected through the CSAFE port to enable this feature and change the speed or incline for a specific user.
EFX	SET CROSSRAMP AUTO-LEVEL	Mid-level of ramp incline range	This prompt appears on equipment with adjustable ramps. Settings range from 1 to 20. Refer to <i>EFX: Changing the Auto-Level Setting</i> .
Cycle	SET RESISTANCE RANGE	High	Settings range from High, Medium, and Low. Refer to <i>Cycle: Setting a Resistance Range</i> .

* This feature is available in all Precor club equipment.

Note: When you make changes in club programming mode, the new settings replace the factory defaults.

Accessing Club Programming Mode and Changing the Settings

Read the *Club Programming Tips* to identify useful information about customizing your Precor equipment.

To access the available menus and change the program settings, perform the following steps:

1. At the Precor banner, press the following keys in sequence without pausing between selections:

RESET, 5, 6, 5, 1, 5, 6, 5

Note: A PAUSE/REST key appears on some products and functions the same as the RESET key.

The club programming prompts appear sequentially and in a menu format. The following table describes which keys to use in club programming mode.

Table 3. Club Programming Mode keys

Key	Description	Function
▲ or ▼	Navigational arrow keys	Moves you through the programs and selections.
OK	OK key	Lets you choose or accept the displayed selection.
CLEAR	Number keypad CLEAR key	Returns to the previous menu level without saving any changes.
RESET	RESET key or PAUSE/RESET key	Exits Club Programming Mode and returns to the Precor banner.

Note: The number keypad is disabled once you enter club programming mode.

Use the following flowchart to navigate through the menu settings on treadmills.

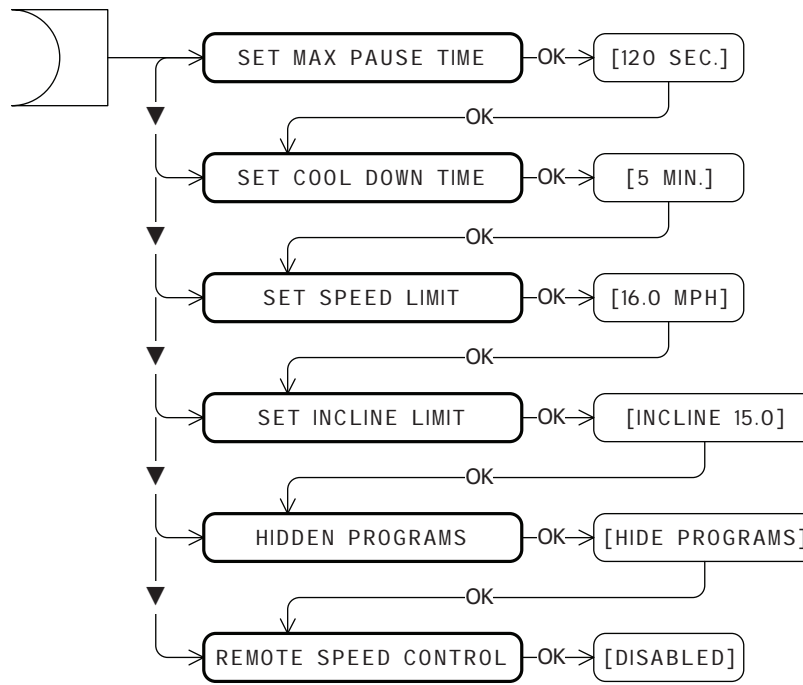
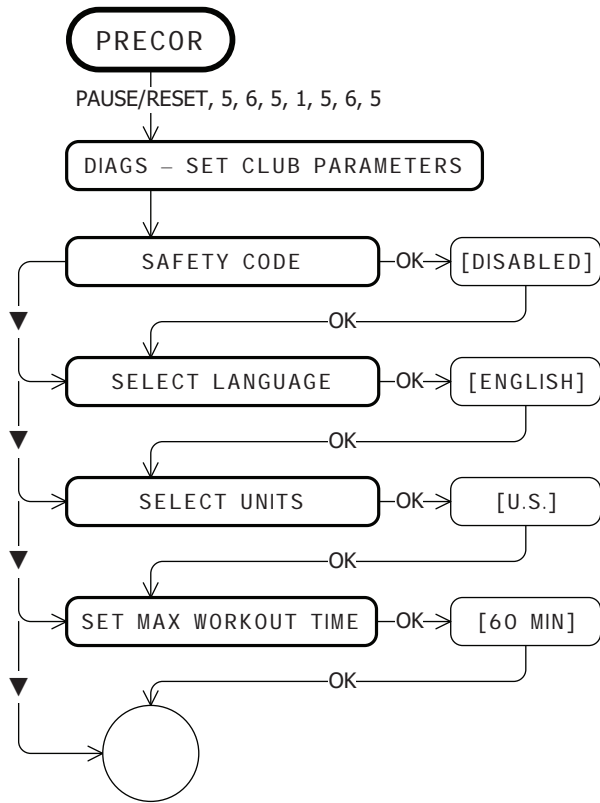

Use the following flowchart to navigate through the menu settings on ellipticals.

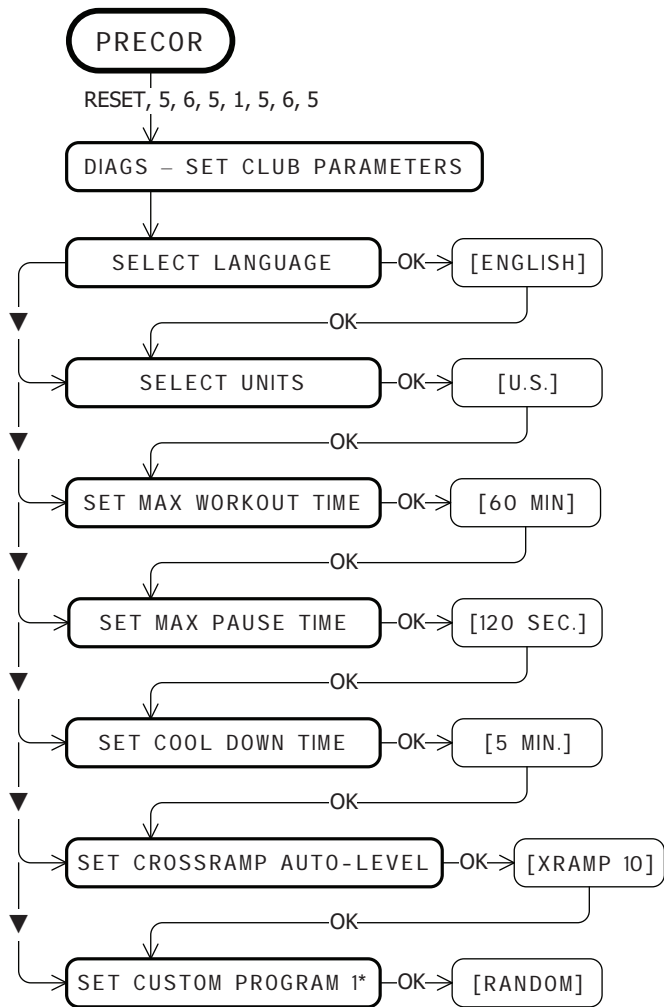

Use the following flowchart to navigate through the menu settings on cycles.

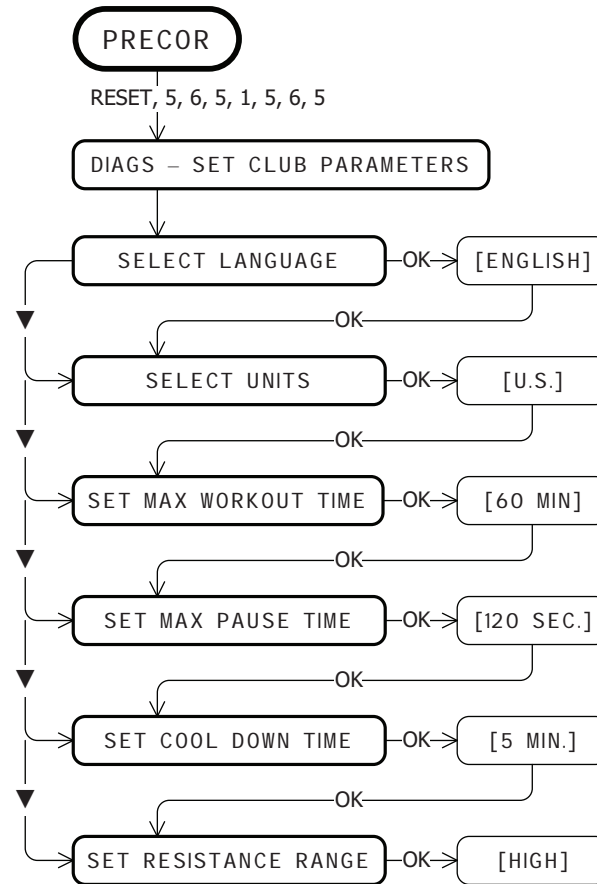

Treadmill: Selecting Safety Code Protection

When the equipment is shipped from the factory, the safety code protection feature is disabled. If you enable the safety code, your patrons will need to enter four number keys in sequence to begin their exercise session and, on the treadmill, start the running belt. If the correct keys are not pressed within two minutes, further access is denied. For more information, refer to *Entering the Safety Code*.

1. At the SAFETY CODE prompt, press OK. Use the navigational arrow keys to alternate between the two selections.

Setting	Description
ENABLED	Causes the safety code prompt to appear prior to a workout and when returning from pause mode.
DISABLED	Does not require a safety code to operate.

CAUTION: Do not assume the equipment is safe because of safety code protection. Never leave children unsupervised around the equipment.

2. When you are ready, press OK to accept the displayed setting and move to the next feature. For further options, refer to the table in *Accessing Club Programming Mode and Changing the Settings*.

Choosing a Language

The equipment can display user prompts, text, and user entries in several different languages. When the equipment is shipped from the factory, it is set to display English.

Note: Programming prompts are not affected by language selection. The prompts in this section continue to appear in English.

1. At the SELECT LANGUAGE prompt, press OK. Use the navigational arrow keys to choose a language.
2. When you are ready, press OK to accept the displayed setting and move to the next feature. For other options, refer to the table in *Accessing Club Programming Mode and Changing the Settings*.

Selecting a U.S. Standard or Metric Display

The equipment can display measurements in either Metric or U.S. Standard. The default factory setting is to display U.S. Standard. To change this setting, perform the following steps:

1. At the SELECT UNITS prompt, press OK. Use the navigational arrow keys to select a unit of measure (US or METRIC).

CAUTION: If you change the Unit of Measure display on a treadmill, be sure to check the speed setting to verify that it is correct. Refer to *Treadmill: Determining the Club Speed Limit*.

2. When you are ready, press OK to accept the displayed setting and move to the next feature. For other options, refer to the table in *Accessing Club Programming Mode and Changing the Settings*.

Setting an Exercise Session Time Limit

You can limit how long a user can exercise on the equipment. For example, if you set the time limit to 20 minutes, users can only enter a session time between 1 and 20 minutes.

Note: The automatic cool-down period is appended to the end of any time-based program, so adjust the time limit accordingly.

You can also let a user exercise indefinitely by selecting NO LIMIT. However, you will need to instruct the users that once they select a program and the workout time appears in the display, they need to use the Number Keypad to type in 240. They must then press the up arrow key to display NO LIMIT, and press OK.

The exercise session times available are between 1 and 240 minutes.

1. At the SET MAX WORKOUT TIME prompt, press OK. Use the navigational arrow keys to change the displayed time limit.

Note: When you press and hold a navigational arrow key, the number increments by five, for example, 1, 5, 10, 15, 20. When you tap an arrow key, the number increments by one.

2. When you are ready, press OK to accept the displayed setting and move to the next feature. For other options, refer to the table in *Accessing Club Programming Mode and Changing the Settings*.

Setting a Pause Time Limit

You can limit how long a user can pause while exercising on the equipment by entering a time between 1 and 120 seconds (two minutes). For example, if you set a pause time limit of 60 seconds, the display automatically resets to the Precor banner if no movement is detected and no key press occurs for one minute.

Important: *The optional power adapter must be connected on self-powered equipment to establish a definitive pause time limit. If the optional power adapter is not attached and the rate of motion drops below the minimum requirements, the equipment begins its 30-second shutdown, effectively eliminating pause mode. Refer to the table in Self-Powered Features.*

1. At the SET MAX PAUSE TIME prompt, press OK. Use the navigational arrow keys to change the time limit. Choose between 1 and 120 seconds (two minutes).
2. When you are ready, press OK to accept the displayed setting and move to the next feature. For other options, refer to the table in *Accessing Club Programming Mode and Changing the Settings*.

Setting a Cool-Down Time Limit

You can limit how long a user cools down after exercising on the equipment by entering a time between 0 and 5 minutes.

Important: *It is highly recommended that you set the cool-down period at or above three minutes. It takes time for a user's heart rate to return to a resting state after vigorous exercise. An effective cool-down period also reduces the amount of lactic acid in muscle tissue.*

1. At the SET COOL DOWN TIME prompt, press OK. Use the navigational arrow keys to display the available time limits. Choose between 0 and 5 minutes. The default setting is 5 minutes.
2. When you are ready, press OK to accept the displayed setting and move to the next feature. For other options, refer to the table in *Accessing Club Programming Mode and Changing the Settings*.

Treadmill: Determining the Club Speed Limit

You can set a maximum speed for the treadmill. This limits how fast the running belt moves and, consequently, the number of speed settings that are available to the user. The speed is displayed in miles per hour (mph) or kilometers per hour (kph) depending upon the units of measure (U.S. standard or Metric) selected earlier. The speed ranges from 0.5 to 12 mph (0.8 to 20kph).

Important: *If you select a number that limits the miles per hour, your change will not affect the kilometers per hour (and vice versa). The treadmill does not convert the speed entered in mph (U.S. standard) to kph (Metric). It stores separate numbers for the different units of measure. To enter both values, you must first reset the display to the appropriate unit of measure, and then change the speed limit in this program. Refer to Selecting a U.S. Standard or Metric Display.*

1. At the SET SPEED LIMIT prompt, press OK. Use the navigational arrow keys to select the desired running belt speed limit.
2. When you are ready, press OK to accept the displayed setting and move to the next feature. For other options, refer to the table in *Accessing Club Programming Mode and Changing the Settings*.

Treadmill: Setting an Incline Limit

You can set the maximum grade (percent of incline) for the treadmill. This limits the degree of incline and, consequently, the number of incline settings that are available to the user. The available range is 0% to 15% grade.

1. At the SET INCLINE LIMIT prompt, press OK. Use the navigational arrow keys to select the desired grade.
2. When you are ready, press OK to accept the displayed setting and move to the next program. For other options, refer to the table in *Accessing Club Programming Mode and Changing the Settings*.

Treadmill: Accessing Performance Programs

The performance-based Gerkin Fitness Test on the treadmill can be hidden from the user's view and, consequently, be unavailable during an exercise session.

If you keep the default factory setting, the Track program appears when the PERFORMANCE key is pressed.

If you wish to change this setting, perform the following steps:

1. Press OK to review the current HIDDEN PROGRAMS selection. Use the navigational arrow keys to alternate between the two selections.

Setting	Description
SHOW PROGRAMS	Causes the Fitness Test to appear and replace the Track program when a user presses the PERFORMANCE key.
HIDE PROGRAMS	Hides the Fitness Test and makes it inaccessible to the user. The Track Program appears when a user presses the PERFORMANCE key.

2. When you are ready, press OK to accept the displayed setting and move to the next program. For other options, refer to the table in *Accessing Club Programming Mode and Changing the Settings*.

Treadmill: Changing Remote Control Access

Important: To affect this setting, the treadmill must be connected to a computer and you will need to be familiar with CSAFE commands.

When you enable this program, you can set a user's speed and incline through a computer software program which interfaces with the CSAFE port on the treadmill.

The default factory setting is set to DISABLED. To change this setting, perform the following steps:

1. At the REMOTE SPEED CONTROL prompt, press OK. Use the navigational arrow keys to alternate between the two selections.

Setting	Description
ENABLED	Lets you set the speed and incline for individual users and their selected program using CSAFE commands through a computer connection.
DISABLED	Disconnects remote access so you cannot use the remote capabilities of a CSAFE connection. You would also use this setting when the treadmill is not connected to a computer.

2. When you are ready, press OK to accept the displayed setting and move to the next program. For other options, refer to the table in *Accessing Club Programming Mode and Changing the Settings*.

EFX: Changing the Auto-Level Setting

You can set a specific ramp incline so that the EFX automatically returns to it at the end of a workout session. Whatever incline you set, the EFX ramp returns to the setting if a user continues pedaling, once the program session has ended, and presses RESET to return to the Precor banner.

Note: This setting is available on equipment with adjustable ramps.

Important: *If you use this feature, connecting the optional power adapter is recommended. Instruct users about the auto-leveling feature and ask that they hold onto a stationary handrail with one hand while the equipment automatically moves to the set incline.*

1. At the SET CROSSRAMP AUTO-LEVEL prompt, press OK.
2. XRAMP *n* appears, where *n* is the ramp incline setting. Some displays only show a number without prefacing it with XRAMP. Use the navigational arrow keys to select the desired ramp incline setting from 1 to 20.
3. When you are ready, press OK to accept the displayed setting and move to the next feature. For other options, refer to the table in *Accessing Club Programming Mode and Changing the Settings*.

Cycle: Setting a Resistance Range

You can set a low, medium or high range of resistance on the recumbent or upright cycles. Within each setting, 25 levels of resistance are available, but the chosen setting affects the overall resistance range.

Physical therapy conditioning is an example where you might use this programming feature. If a user has an injury that needs low levels of resistance, you might set the resistance range to low to make sure that the user does not induce further injury by exceeding your recommended levels of resistance.

The following table provides short descriptions of each group.

Table 4. Resistance range settings on cycles

Setting	Description
HI or HIGH	Provides the full range of resistance available. If an upright cycle user chooses the high-end resistance levels, the cycle provides enough resistance to simulate sprinting or hill climbing for users wishing to stand on the upright cycle. It also provides enough resistance for elite riders that are capable of spinning at high speed with high resistance.
MED or MEDIUM	Provides approximately two thirds of the resistance that is available within the high group setting. Club owners may want to select the medium range for recumbent cycles. Since users cannot stand on recumbent cycles, less resistance is needed by the average (non-elite) user. A medium range may provide more comfort. It also allows users to make easier resistance changes in the preset programs.
LO or LOW	Provides approximately one third of the resistance that is available within the high group setting. The low range may be appropriate in special situations where poorly conditioned users are anticipated. The low range is not recommended for the club environment.

1. At the SET RESISTANCE RANGE prompt, press OK. Use the navigational arrow keys, to choose LOW, MEDIUM or HIGH (LO, MED, or HI on some equipment).
2. When you are ready, press OK to accept the displayed setting and move to the next feature. For other options, refer to the table in *Accessing Club Programming Mode and Changing the Settings*.

Informational Displays

The equipment provides information about its use (odometer and hour meter), as well as software versions and part numbers, serial number, usage log, and error log. In general, you would only access this information if directed to do so by Precor Customer Support.

To navigate through the informational displays, use the following flowchart. Descriptions for these displays are shown in the following table.

Note: The CLEAR key is located on the Number Keypad. If your product has a PAUSE/RESET key, use it in place of the RESET key called out in the flowchart.

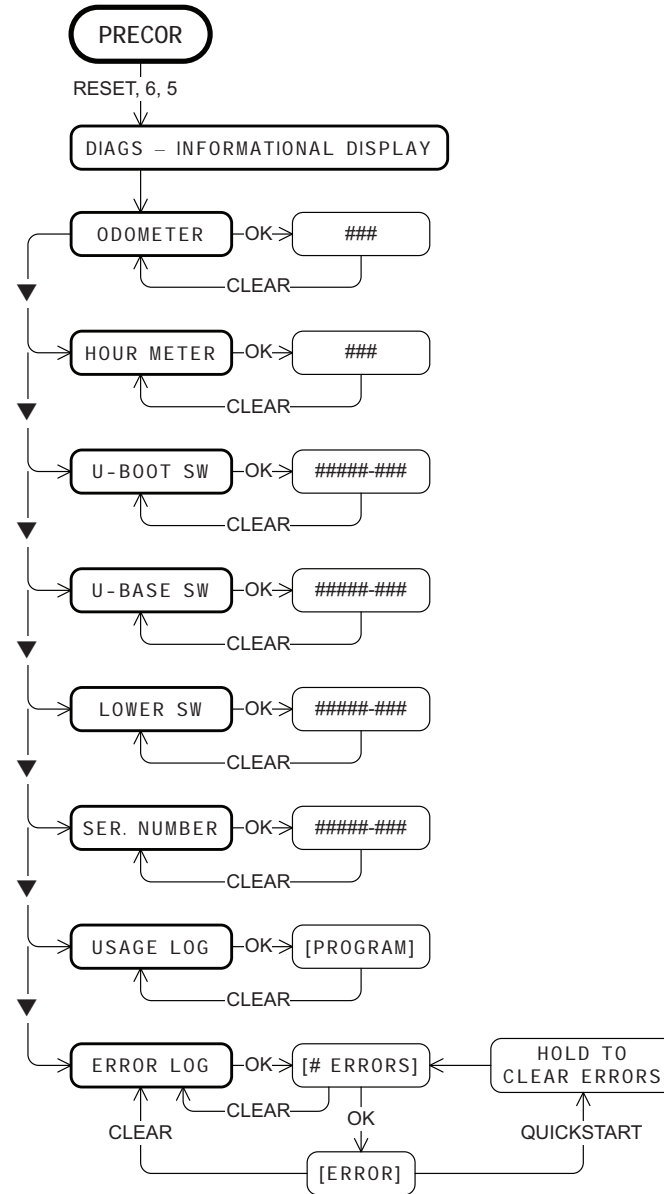

Table 5. Informational Displays

Product	Display	Description
All	ODOMETER	The odometer value correlates to the type of Precor product and the standard of units, U.S. or Metric, selected in the club programs. Treadmill shows the number of cumulative miles or kilometers logged to date. EFX or AMT shows the number of total strides logged to date. Cycle shows the number of total revolutions logged to date. Climber indicates the number of floors climbed.
All	HOUR METER	The number of hours that the equipment has been in use. The equipment tracks the elapsed minutes, but the value that appears is truncated to the nearest full hour.
All	U - BOOT SW	Upper board application software part number and version. Note: Some displays show UPPER BOOT SW PART NUMBER.
All	U - BASE SW	Upper base application software version. Note: Some displays show UPPER BASE SW PART NUMBER.
All	LOWER SW	Lower application software version. Note: Some displays show LOWER BASE SW PART NUMBER.
534i, 532i, AMT	METRICS BOARD SW PART NUMBER	Metrics board software part number and version.
AMT	STRIDE DIAL SW PART NUMBER	Stride dial software part number.
All	SER. NUMBER	The serial number is helpful when you contact Customer Support. You can also find the serial number located on a label on the front hood (treadmills) or optional power receptacle (self-powered equipment) if one does not appear in the display. Note: Some displays show SERIAL NUMBER.
All	USAGE LOG	The software logs the number of times each program has been used and displays the associated cumulative minutes. The usage log is helpful in determining user preferences in program selection.
All	ERROR LOG	The error log displays any error codes that may have been detected by the software. Copy the error code information to paper so you can provide it to Customer Support, if needed. Be sure to copy it exactly as shown. Refer to <i>Error Log</i> .

Error Log

Quick access to the informational display is available if error messages have appeared on the display and have been recorded in the error log. This feature is usually reserved for service personnel. At the Precor banner, press and hold RESET for 4 seconds. If `DIAGS - INFORMATION DISPLAY` or `ERROR LOG` appears, press OK.

If no errors are logged, `STOP KEY` or `STUCK KEY` appears. When you release the key, the Precor banner returns.

Note: On treadmills, the red STOP button can be used instead of the PAUSE/RESET key.

Erasing the Error Log

When you no longer need the error log information, you may erase all entries in the error log by pressing the QUICKSTART key while any error description is scrolling across the display. Continue to maintain light pressure on the key until the message, `HOLD TO CLEAR ERRORS`, scrolls off the display. When the key is released, `NO ERRORS` appears on the display, which indicates the error log has been deleted.

Important: You cannot retrieve the error log once you have deleted it. You may want to resolve any issues you are experiencing with the equipment before erasing the error log.

When you are ready, press RESET to return to the Precor banner.

User ID Entry with CSAFE Equipment

The equipment is fully compatible with CSAFE protocols. When the equipment is connected to a CSAFE master device, the user is prompted to press ENTER and begin an identification process.

The user ID is displayed as five zeros and indicates the starting point. The following table describes key functions while in CSAFE mode.

Table 6. CSAFE access keys

Keypad	Description
Number keypad	Use the number keys to enter a user ID. The number that is pressed appears on the right. As the user continues, the numbers fill in the display from right to left. When all five numbers are in place, the user must press ENTER or OK to submit the user ID.
CLEAR or BACK	Erases individual numbers in the user ID from right to left.
ENTER or OK	Submits the user ID. Note: User ID entry is bypassed when the user enters five zeros. No workout statistics are recorded.
RESET or PAUSE/RESET	Resets the display to the banner.

A message appears on the display and indicates when the user ID is accepted by the CSAFE master device. Once program selection is complete, the user can begin exercising.

To review information about CSAFE specifications, visit the web site at: www.fitlinxx.com/csafes

If you have questions or need technical support, refer to *Obtaining Service*.

Maintenance

It is important to perform the minor maintenance tasks described below. Failure to maintain the equipment as described in this section could void the Precor Limited Warranty.

DANGER To reduce the risk of electrical shock, always unplug the equipment from its power source (an optional power adapter in the case of self-powered equipment) before cleaning it or performing any maintenance tasks.

Daily Inspection

Look and listen for slipping belts, loose fasteners, unusual noises, worn or frayed power cords, and any other indications that the equipment may be in need of service. If you notice any of these, obtain service.

On treadmills, check for worn, frayed or missing safety lanyards. Replace missing or worn safety lanyards immediately. Make sure users attach the safety clip to their clothing before exercising on the treadmill.

Important: If you determine that the equipment needs service, disconnect any power connections and move the equipment away from the exercising area. Place an **OUT OF SERVICE** sign on it and make sure all patrons and users know that they must not use the equipment.

To order parts or to contact a Precor authorized service provider in your area, refer to *Obtaining Service*.

Daily Cleaning

Precor recommends the equipment be cleaned before and after each exercise session. Use mild soap and water to dampen a clean, soft cloth and wipe all exposed surfaces. This helps remove dust and dirt.

CAUTION: Do not use any acidic cleaners. Doing so will weaken the paint or powder coatings and void the Precor Limited Warranty. Never pour water or spray liquids on any part of the equipment. Allow the equipment to dry completely before using.

Frequently vacuum the floor underneath the equipment to prevent the accumulation of dust and dirt, which can affect the smooth operation of the equipment. Use a soft nylon scrub brush to clean the running belt on treadmills or the grooves on equipment with foot pedals.

CAUTION: On treadmills, as you clean the hood or side rails, be aware of the handrail extensions so you do not inadvertently hit your head or injure yourself.

EFX: Cleaning the Ramp

Whenever the ramp becomes soiled, clean the exposed surfaces of the ramp and roller wheels by taking the following steps.

Note: If your equipment has a ramp cover, remove it before performing the following steps. Refer to the *EFX Assembly Guide*.

1. Moisten a clean, soft cloth in a mild solution of soap and water.
2. Position one foot pedal at the top of the ramp (the other will automatically be positioned at the bottom).
3. Clean the exposed portions of the ramp.
4. Gently lift the roller wheels. Rotate each wheel while wiping it with the clean, soft cloth.
5. Switch the foot pedal position and finish cleaning the ramp.

Storing the Chest Strap

If you purchased the optional heart rate chest strap, store it in a place where it remains free of dust and dirt (for example, in a closet or drawer). Be sure to protect the chest strap from extremes in temperature. Do not store it in a place that may be exposed to temperatures below 32° F (0° C).

To clean the chest strap, use a sponge or soft cloth dampened in mild soap and water. Dry the surface thoroughly with a clean towel.

Treadmill: Checking the Alignment of the Running Belt

Proper belt alignment allows the belt to remain centered and ensures smooth operation. Realigning the belt takes a few simple adjustments. If you are unsure about this procedure, call Precor Customer Support. Refer to *Obtaining Service*.

CAUTION: Special care must be taken when aligning the running belt. Turn Off the treadmill while adjusting or working near the rear roller. Remove any loose clothing and tie back your hair. Be very careful to keep your fingers and any other object clear of the belt and rollers, especially in front of the roller and behind the deck. The treadmill will not stop immediately if an object becomes caught in the belt or rollers.

1. Make sure that the running surface is level. To operate correctly, the treadmill needs to be as level as possible. If needed, the rear feet can be adjusted to level the treadmill (refer to the *Assembly Guide*).
2. Turn the equipment On.
3. Stand beside the treadmill and press QUICKSTART.
4. If needed, enter the safety code by pressing the number keys in sequence: 1, 2, 3, 4.

The running belt starts automatically after a 3-second countdown appears on the display.

5. Press the SPEED up key until the display shows a speed of 3 mph (5 kph).

CAUTION: If you hear any chafing or the running belt appears to be getting damaged, stop the running belt immediately by pressing the red STOP button. Contact Precor Customer Support.

6. Walk around to the rear of the equipment and observe the belt for a few minutes. The belt should run centered along the running bed. If the belt drifts off center, you must make adjustments. Refer to *Treadmill: Adjusting the Running Belt*.

Important: Failure to align the belt may cause the belt to tear or fray, which is not covered by the Precor Limited Warranty.

7. To stop the running belt, press the red STOP button.
8. Turn the treadmill Off.

Treadmill: Adjusting the Running Belt

If you are unsure about adjusting the running belt, call Precor Customer Support (refer to *Obtaining Service*).

CAUTION: For your safety, use the power switch to turn Off the treadmill before making any adjustments. Do not adjust the running belt when someone is standing on the equipment.

1. Locate the right belt adjustment bolt in the rear end cap of the treadmill as shown in the following figure.

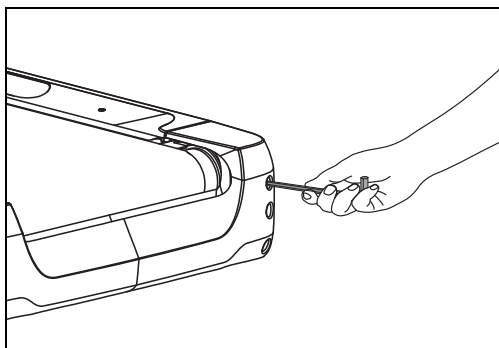

Figure 4: Location of the adjustment bolt

To determine left and right, stand at the rear of the treadmill and face the display. Make all belt adjustments on the right rear corner bolt using the hex key provided.

- If the belt is off center to the LEFT, turn the adjusting bolt $\frac{1}{4}$ turn *counterclockwise*, which moves the running belt to the right.
- If the belt tracks off center to the RIGHT, turn the bolt $\frac{1}{4}$ turn *clockwise*; this moves the belt to the left.

Important: Do not turn the adjusting bolt more than $\frac{1}{4}$ turn at a time. Overtightening the bolt can damage the treadmill.

2. Recheck the alignment of the running belt by repeating the steps found in *Treadmill: Checking the Alignment of the Running Belt*.

Upright Cycle: Adjusting the Seat Tilt

To adjust the seat tilt on an upright cycle, take the following steps.

1. Use a $1\frac{1}{16}$ -inch (17 mm) box-end wrench or crescent wrench to loosen the nut beneath the seat as shown in the following figure.

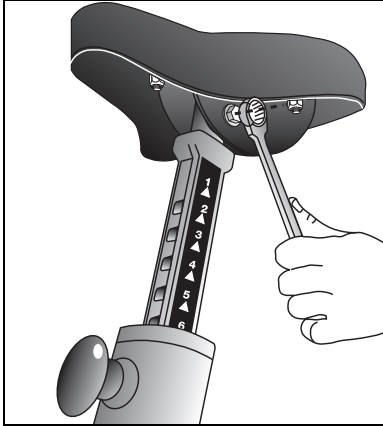

Figure 5: Loosen nut to adjust seat tilt

2. Adjust the seat tilt (forward or backward) as shown in the following figure.

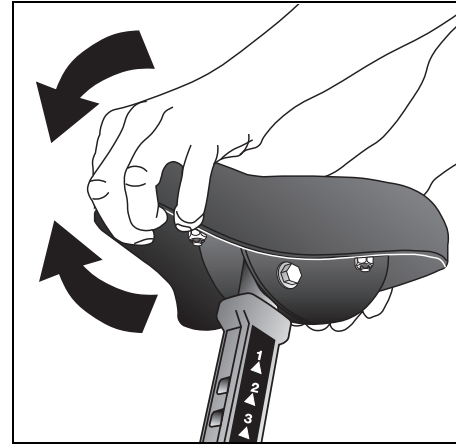

Figure 6: Tilt the seat forward or backward

3. Wrench tighten the nut
4. Apply pressure to the seat and make sure that it does not move. Readjust and retighten the nut, if needed.

Recumbent Cycle: Realigning the Seat

If the seat rocks side-to-side, you need to realign the center wheel underneath the seat. Adjustment screws are located on the left side of the seat rail.

To remove seat wobble (side-to-side movement), take the following steps.

1. Obtain a $\frac{3}{16}$ -inch and $\frac{5}{16}$ -inch hex key.
2. Use the $\frac{3}{16}$ -inch hex key to loosen the two adjustment screws as shown in the following figure.

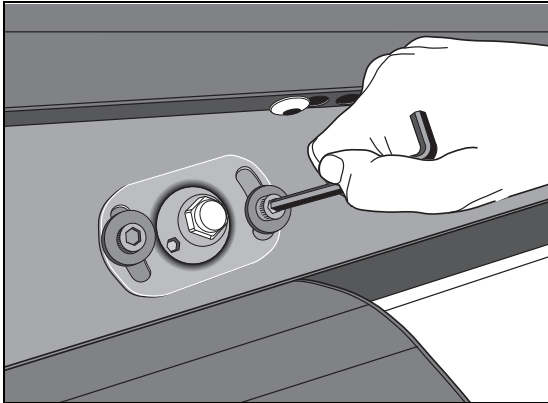

Figure 7: Loosen the two adjustment screws

3. Use the $\frac{5}{16}$ -inch hex key to turn the wheel lock adjustment key clockwise $\frac{1}{4}$ turn as shown in the following figure. This process realigns the center wheel inside the top rail. Leave the $\frac{5}{16}$ -inch hex key in place while you tighten the adjustment screws with the $\frac{3}{16}$ -inch hex key.

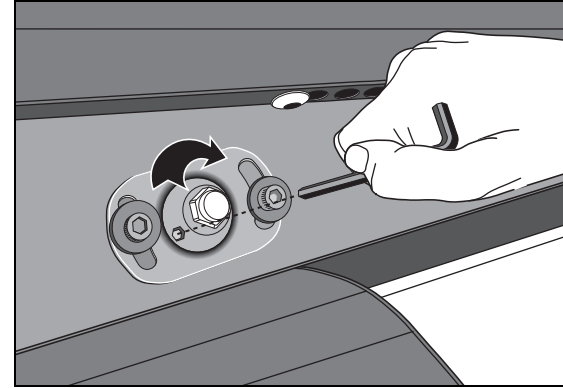

Figure 8: Wheel lock adjustment

4. Remove the hex keys and check that the seat no longer rocks side-to-side. If the rocking movement continues, you need to repeat steps 2 and 3.

Moving the Equipment

It is important, if you plan to move the equipment, that you obtain adult help and use proper lifting techniques. The equipment is very heavy. Take advantage of the roller wheels on the equipment when moving it to a new location.

Important: *The plastic end cap, on the treadmill, is specifically designed for lifting. To avoid injury to yourself or damage to the equipment, ask for help in placing the treadmill where you plan to use it. Place a hand under each end of the end cap and, using proper lifting techniques, lift the rear of the treadmill so that it rolls on its front wheels.*

Long-Term Storage

When the equipment is not in use for any length of time, make sure it is turned Off (treadmill only) and the power cord or optional power adapter (self-powered equipment) is unplugged from its power source and is positioned so that it will not become damaged or interfere with people or other equipment.

Precor Commercial Equipment Limited Warranty

PLEASE READ THESE WARRANTY TERMS AND CONDITIONS CAREFULLY BEFORE USING YOUR PRECOR INCORPORATED PRODUCT. BY USING THE EQUIPMENT, YOU ARE CONSENTING TO BE BOUND BY THE FOLLOWING WARRANTY TERMS AND CONDITIONS.

Limited Warranty.

Precor Incorporated warrants all new Precor products to be free from defects in materials and manufacture for the warranty periods set forth below. The warranty periods commence on the invoice date of the original purchase. This warranty applies only against defects discovered within the warranty period and extends only to the original purchaser of the product. Parts repaired or replaced under the terms of this warranty will be warranted for the remainder of the original warranty period only. To claim under this warranty, the buyer must notify Precor or your authorized Precor dealer within 30 days after the date of discovery of any nonconformity and make the affected product available for inspection by Precor or its service representative. Precor's obligations under this warranty are limited as set forth below.

Warranty Periods and Coverage.

Commercial Cardiovascular Products, also known as C-Series Products, (excluding StretchTrainer, Strength Products).

- Seven years frame, five years display face assembly, three years motor controller, one year durable wear parts, two years parts, one year labor.
- For treadmills, five years drive motor.
- For self-powered ellipticals and bikes, one year battery.
- For InSite, one year parts and labor.
- Labor coverage for options as defined below.

StretchTrainer

Five years frame, two years parts, 90 days upholstery, no labor.

Strength Products (S3.45 and S3.25 only)

Ten years frame; three years bearings, guide rods, cams, pulleys; one year belts, cables, hand grips, miscellaneous parts; 90 days upholstery; no labor.

Options / Accessories / Battery-powered or Self-Operated Devices

Many options or accessories have components that are connected internally or mounted inside the electronic console. The following guidelines determine the warranty for these components. If the internal components are installed by the factory or by an authorized dealer as part of the original sale and delivery, they have a warranty that is identical to the warranty of the equipment in which they are connected or mounted. If the internal components are not installed by the factory or by an authorized dealer as part of the original sale and delivery, they have a 90 days parts and labor limited warranty. All components that are not internally connected have a 90 days parts only limited warranty. Satisfactory proof of purchase is required in all cases.

Conditions and Restrictions.

This warranty is valid only in accordance with the conditions set forth below:

1. The warranty applies to the Precor product only while
 - a. it remains in the possession of the original purchaser and proof of purchase is demonstrated,
 - b. it has not been subjected to accident, misuse, abuse, improper service, or non-Precor modification.
 - c. claims are made within the warranty period.
2. Certain products are warranted for standard commercial use only (defined as use in non-fee paying clubs or facilities and less than 6 hours daily use. Unapproved use voids the warranty. Current standard commercial products include C936i, C932i, EFX524i, EFX534i.).
3. This warranty does not cover damage or equipment failure caused by electrical wiring not in compliance with electrical codes or Precor owner's manual specifications, or failure to provide reasonable and necessary maintenance as outlined in the owner's manual.
4. Except in Canada, Precor does not pay labor outside the United States.
5. Warranties outside the United States and Canada may vary. Please contact your local Dealer for details.

This Limited Warranty shall not apply to:

1. Software (PROM) version upgrades.
2. Normal wear and tear, consumables and cosmetic items, including, but not limited to the following: grips, seats, and labels.
3. Repairs performed on Precor equipment missing a serial number or with a serial tag that has been altered or defaced.
4. Service calls to correct installation of the equipment or instruct owners on how to use the equipment.
5. Pickup and delivery involved with repairs.
6. Any labor costs incurred beyond the applicable labor warranty period.

Disclaimer and Release.

The warranties provided herein are the exclusive warranties given by Precor and supersede any prior, contrary or additional representations, whether oral or written. ANY IMPLIED WARRANTIES, INCLUDING THE WARRANTY OF MERCHANTABILITY OR FITNESS FOR A PARTICULAR PURPOSE THAT APPLY TO ANY PARTS DESCRIBED ABOVE ARE LIMITED IN DURATION TO THE PERIODS OF EXPRESS WARRANTIES GIVEN ABOVE FOR THOSE SAME PARTS. PRECOR HEREBY DISCLAIMS AND EXCLUDES THOSE WARRANTIES THEREAFTER. Some States do not allow limitations on how long an implied warranty lasts, so the above limitation may not apply to you. PRECOR ALSO HEREBY DISCLAIMS AND EXCLUDES ALL OTHER OBLIGATIONS OR LIABILITIES, EXPRESS OR IMPLIED, ARISING BY LAW OR OTHERWISE, WITH RESPECT TO ANY NONCONFORMANCE OR DEFECT IN ANY PRODUCT, INCLUDING BUT NOT LIMITED TO: (A) ANY OBLIGATION, LIABILITY, RIGHT, CLAIM OR REMEDY IN TORT, WHETHER OR NOT ARISING FROM THE NEGLIGENCE OF PRECOR OR ITS SUPPLIERS (WHETHER ACTIVE, PASSIVE OR IMPUTED); AND (B) ANY OBLIGATION, LIABILITY, RIGHT, CLAIM OR REMEDY FOR LOSS OF OR DAMAGE TO ANY EQUIPMENT. This disclaimer and release shall apply even if the express warranty set forth above fails of its essential purpose.

Exclusive Remedies.

For any product described above that fails to conform to its warranty, Precor will provide, at their option, one of the following: (1) repair; (2) replacement; or (3) refund of the purchase price. Precor Limited Warranty service may be obtained by contacting the authorized dealer from whom you purchased the item. Precor compensates Servicicers for warranty trips within their normal service area to repair commercial equipment at the customer's location. You may be charged a trip charge outside the service area. THESE SHALL BE THE SOLE AND EXCLUSIVE REMEDIES OF THE BUYER FOR ANY BREACH OF WARRANTY.

EXCLUSION OF CONSEQUENTIAL AND INCIDENTAL DAMAGES.

PRECOR AND/OR ITS SUPPLIERS SHALL HAVE NO OBLIGATION OR LIABILITY, WHETHER ARISING IN CONTRACT (INCLUDING WARRANTY), TORT (INCLUDING ACTIVE, PASSIVE, OR IMPUTED NEGLIGENCE AND STRICT LIABILITY), OR OTHERWISE, FOR DAMAGE TO THE EQUIPMENT, PROPERTY DAMAGE, LOSS OF USE, REVENUE OR PROFIT, COST OF CAPITAL, COST OF SUBSTITUTE EQUIPMENT, ADDITIONAL COSTS INCURRED BY BUYER (BY WAY OF CORRECTION OR OTHERWISE) OR ANY OTHER INCIDENTAL, SPECIAL, INDIRECT, OR CONSEQUENTIAL DAMAGES, WHETHER RESULTING FROM NONDELIVERY OR FROM THE USE, MISUSE OR INABILITY TO USE THE PRODUCT. This exclusion applies even if the above warranty fails of its essential purposes and regardless of whether such damages are sought for breach of warranty, breach of contract, negligence, or strict liability in tort or under any other legal theory. Some states do not allow the exclusion or limitation of incidental or consequential damages, so the above limitation may not apply to you.

This warranty gives you specific legal rights, and you may also have other rights, which vary from state to state.

Complete this portion and keep for your records.

Purchased From: _____
(Dealer or store name)

Phone Number: _____
(Dealer or store telephone number)

Product/Model: : _____
(For example: EFX534i or C966i)

Serial Number: : _____
(The serial number is found on the shipping container.)

Effective 27 March, 2006
P/N 36286-112

Thank You and Welcome to Precor



We are confident that you will be pleased with your purchase and that your new Precor equipment will help satisfy your customers' fitness needs, while helping you meet your business goals.

To allow us to serve you better, please take a few moments to complete and return your warranty registration.

YOU MAY ALSO REGISTER ONLINE AT
www.precor.com/warranty

If you have questions or need additional information, contact your local dealer or call Precor Commercial Products Customer Support at 888-665-4404.

Fold along dotted line and tape closed before mailing.

COMM.

Woodinville, WA 98072-4002

PO Box 7202

20031 142nd Avenue NE

Precor Incorporated



PLACE
STAMP
HERE

TELL US ABOUT YOUR NEW PRECOR PRODUCTS

Date of Purchase:

Month Day Year

Purchased from (Dealer name):

Product Serial Number(s):

Please indicate the type and number of products purchased:

#: _____ Elliptical Fitness CrossTrainer (EFX®)
 #: _____ Treadmill #: _____ Stair Climber
 #: _____ Cycle #: _____ Strength Station
 #: _____ StretchTrainer™

The serial number is located on the shipping box and on the product.

Add additional sheets of paper or register online at www.precor.com/warranty

TELL US ABOUT YOUR FACILITY

Name of Facility _____

Mr. M/s. Ms.
 Contact Person — First Name _____ Last Name _____

Facility Address _____ Apt./Suite _____

City _____ State _____ Zip Code _____

Area Code _____ Facility Telephone Number _____

Your Business Email Address _____

How many members do you have?

Less than 100 100 – 500 500 – 1000 1000 – 2000 2001 +

What percentage of floor space do you allocate for cardio equipment?

0% to 20% 20% to 40% 40% to 60% 60% to 80% 80% to 100%

What type of equipment makes up your cardio offering (check all that apply)?

Treadmills Ellipticals Cycles Stair Climbers Rowing Machines Other _____

What other brands of cardio equipment do you currently offer (check all that apply):

Life Fitness True Cybex StarTrac Other _____

What other Precor equipment do you currently offer (check all that apply):

EFX Cycle StretchTrainer™ Treadmill Stair Climber Strength Machine Other _____

TELL US ABOUT YOUR PURCHASE

Which best describes this purchase (check all that apply):

First Precor product Replaces a Precor product of the same type
 Replaces same type of product – different brand Enhancement to equipment already owned

How did you FIRST become aware of this product (choose only one):

Authorized Precor dealer Precor sales representative Trade show/conference
 Internet News report or product review Club/fitness magazine advertisement
 Trade/consumer magazine article Other _____

What factors MOST influenced your decision to purchase this product (choose up to three):

Precor reputation Prior product experience Design/appearance Value for the price
 Special product features Warranty Service Rebate or sale price

Please detach and mail in the warranty registration within ten days of purchase.



Precor Incorporated
20031 142nd Ave NE
P.O. Box 7202
Woodinville, WA USA 98072-4002
1-800-347-4404

Precor, C, CrossRamp, EFX, M, Move Beyond, and SmartRate are registered trademarks of Precor Incorporated.
Crosstrainer, QuickStart, and StretchTrainer are trademarks of Precor Incorporated.
Copyright 2008 Precor Incorporated.
Specifications subject to change without notice.
www.precor.com

NOTICE:

Precor is widely recognized for its innovative, award winning designs of exercise equipment. Precor aggressively seeks U.S. and foreign patents for both the mechanical construction and the visual aspects of its product design. Any party contemplating the use of Precor's product designs is hereby forewarned that Precor considers the unauthorized appropriation of its proprietary rights to be a very serious matter. Precor will vigorously pursue all unauthorized appropriation of its proprietary rights.



POM C-V 49336-104, en
Warranty # 36286-112, en
Registration Card# 45622-101, en
03 March 2008

User's Reference Manual

C842i

Commercial Cycle



PRECOR[®] USA
move beyond[®]

Important Safety Instructions

When using the C842i Upright or Recumbent Cycle, always take basic precautions, including the following:

- Read all instructions before using the cycle. These instructions are written for your safety and to protect the unit.
- Take time to discuss proper safety and exercise equipment etiquette with the club or facility manager.
- Before beginning any fitness program, see your physician for a complete physical examination.

Il est conseillé de subir un examen médical complet avant d'entreprendre tout programme d'exercice. Si vous avez des étourdissements ou des faiblesses, arrêtez les exercices immédiatement.

- Do not allow children or those unfamiliar with its operation on or near the cycle. Do not leave children unsupervised around the unit.
- Wear proper exercise clothing and shoes for your workout and avoid loose clothing. Do not wear shoes with heels or leather soles. Check the soles of your shoes and remove any dirt and embedded stones. Tie long hair back.
- Use care when getting on or off the cycle. Use the handlebar for stability.
- For safety, hold onto the handlebar while mounting the cycle, getting comfortably situated on the seat, and dismounting the cycle.

- Keep your body and head facing forward. Never attempt to turn around on the cycle.
- Do not rock the unit. Do not stand on the handlebars, display console, or covers.
- Never place your hands or feet in the path of the pedals because injury may occur to you or damage may occur to the unit.
- Do not overexert yourself or work to exhaustion. If you feel any pain or abnormal symptoms, stop your workout immediately and consult your physician.

Obtaining Service

The club owner or facility manager can help you with most questions regarding the cycle. For additional information about product operation or exercise routines, refer to the Precor web site at www.precor.com.

Table of Contents

Important Safety Instructions	1	Workout Options	15
Obtaining Service	1	Choosing QUICKSTART	16
Cycle Features	3	Selecting a Program	17
Self-Powered Features	3	Changing Programs in Mid-session	17
Using the Handlebars	3	Cooling Down After a Workout	18
Adjusting the Seat	3	Pausing During a Workout or the Cool-Down Period	18
Heart Rate Features	4	Ending a Workout	19
Important Use and Safety Information	4	Programs	20
Using SmartRate	5	Choosing a Program	20
Exercise to Your Target Heart Rate	7	Program Tips	20
Heart Rate Analysis	7	Manual Program	21
Display Console	8	Interval Program	21
More Information about the Center Display	9	Random Program	21
More Information about the Lower Display	9	Basic HRC Program	22
Keypads	11	Weight Loss Program	23
		Hill Climb Program	23

Cycle Features

The cycle is equipped with certain items that, when used properly, help sustain an enjoyable workout. These items include:

- Self-powered features
- Seat adjustments

Important: Before exercising, review the Important Safety Instructions found at the beginning of this manual.

Self-Powered Features

The cycle does not require an electrical power connection. It has an internal battery that is recharged every time you exercise for a reasonable period of time. A pedaling speed above 20 RPM must be maintained for several seconds before information appears on the display. Once the Precor banner appears, you can press QUICKSTART or a PROGRAMS key to begin exercising. For more information, refer to *Workout Options*.

Using the Handlebars

To maintain your balance on the cycle, always grasp a handlebar while getting comfortably situated on the seat. Maintain your comfort and balance by grasping a handlebar when you use the keypad or when you dismount.

Adjusting the Seat

Information on how to adjust the seat and seat tilt is found in the *Product Owner's Manual*. Refer to that manual or ask club personnel to show you the proper techniques.

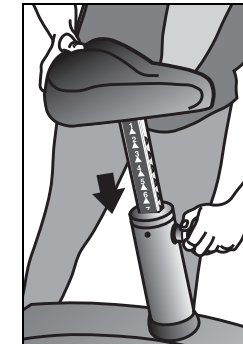
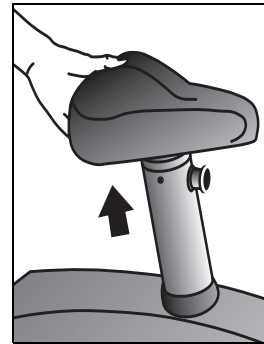

Diagram 1: Adjusting the seat on the C842i Upright Cycle

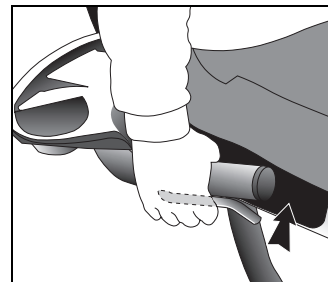
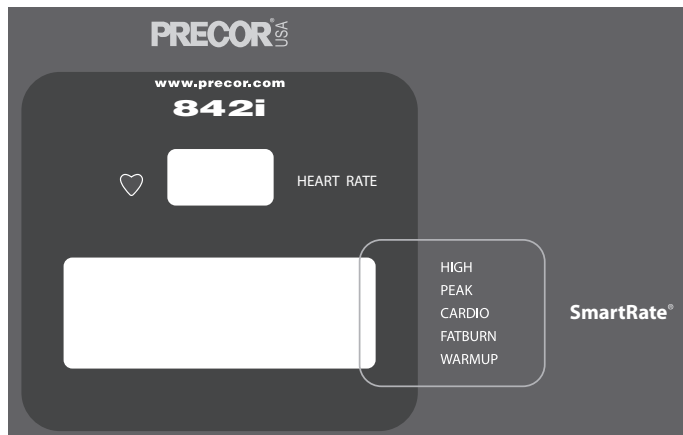

Diagram 2: Adjusting the seat on the C842i Recumbent Cycle

Heart Rate Features



Heart rate and SmartRate® features are available when you wear the chest strap. When a heartbeat is detected, the HEART RATE display shows your heart rate and, if your age has been entered, the SmartRate LED pulses and indicates your target zone.

Important Use and Safety Information

Read the following before using the heart rate or SmartRate features.

- Consult your physician before engaging in any vigorous exercise. Do not use the heart rate program until authorized by your physician.
- Know your heart rate and your physician-recommended heart rate target zone. Individual heart rates vary according to several physiological factors and may not correspond directly with Diagram 3.

- The calculation used for the heart rate target zone is:
(220 minus your age) multiplied by a percent.

Refer to Table 1 in *Using SmartRate*.

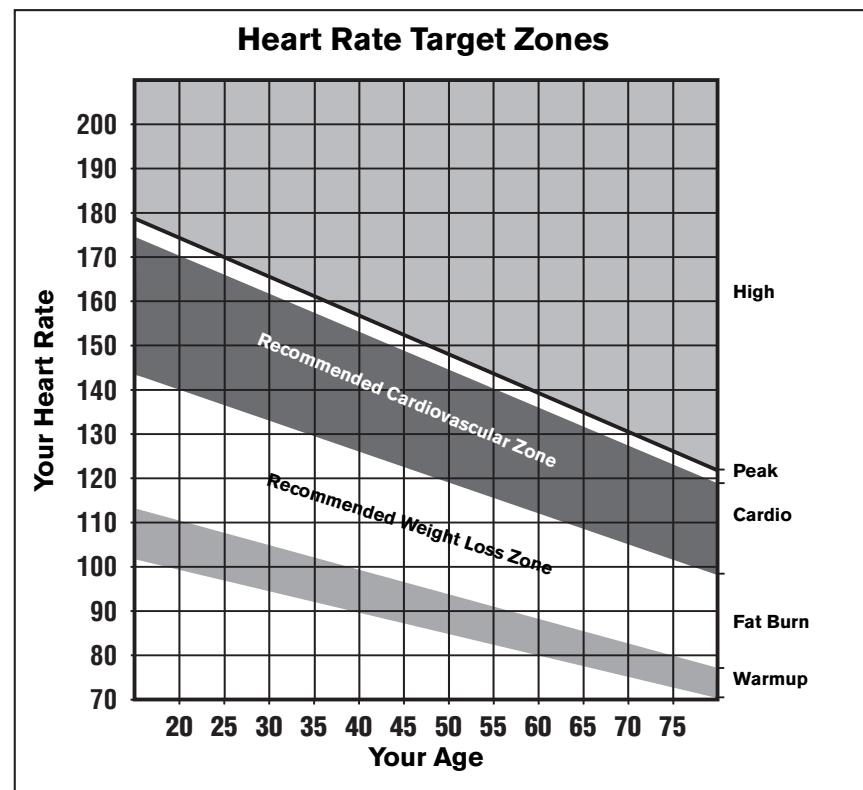

Diagram 3: Heart rate target zones

- After you put on the chest strap, face the display console for a minimum of 15 seconds. This allows the receiver in the console to recognize the signal from the chest strap. If **Hr** blinks in the HEART RATE display, the cycle is detecting a signal, but has not yet determined your heart rate. Make sure the chest strap is positioned properly around your chest and against your skin.
- When a signal is detected, a number flashes in the HEART RATE display and indicates your heart rate. The heart rate indicator blinks in rhythm to your heart rate. If no signal is detected, the HEART RATE display appears blank and the heart rate indicator remains lit without blinking.
- Always face forward on the cycle and use the handlebars for balance.
- Maintain a consistent pedaling speed while exercising. Find a comfortable pedaling speed between 20 and 150 revolutions per minute.

Using SmartRate

The SmartRate feature helps you monitor and maintain your heart rate in the target zone best suited to your specific needs. When the cycle detects a heart rate, a single LED blinks and indicates the zone that your heart rate is in.

Important: To use the SmartRate feature, you must enter your age during program selection. Refer to Selecting a Program.

The 7 LEDs in the SmartRate display are color-coded. Pulsating orange LEDs indicate you are exercising outside the recommended heart rate target zone. Green LEDs indicate when you are exercising within the recommended fat burn or cardio fitness zones.

Table 1 shows the percents used in calculating the heart rate target zones. While your heart rate remains within these zones, the corresponding lights blink and provide a visual cue.

The calculation used to determine your maximum aerobic heart rate is (220 minus your age). When you multiply it by the percent indicated in Table 1, you can understand the relationship between the pulsating LED and your target heart rate.

CAUTION: Your heart rate should never exceed 85% of your maximum aerobic heart rate or go above PEAK. If it does, immediately reduce your pedaling speed or adjust the resistance to return your heart rate to your physician-recommended target zone.

Table 1. Heart rate target zones and SmartRate LEDs

<i>Heart Rate Zone Percent</i>	<i>LED Lit</i>	<i>LED Blinking</i>	<i>Zone Label</i>
Below 55	First	Orange	WARMUP
55 to 61	Second	Green	FAT BURN
62 to 69	Third	Green	FAT BURN
70 to 77	Fourth	Green	CARDIO
78 to 84	Fifth	Green	CARDIO
85 to 87	Sixth	Orange	PEAK
Above 87	Seventh	Orange	HIGH

The SmartRate indicator lights do not blink when:

- You do not wear or improperly position the chest strap.
- You do not enter your age before or during an exercise session.

For example, pressing QUICKSTART at the Precor banner causes the Manual Program to begin. Your age has not been entered and is considered a null value. All LEDs in the SmartRate display appear, but none blink, because the appropriate calculations have not been made.

Note: You can remedy this situation by choosing a program using one of the PROGRAMS keys and entering your workout time, weight, and age.

Refer to *Fitness Tools* on the Precor web site www.precor.com for exercise suggestions and routines.

Exercise to Your Target Heart Rate

A heart rate receiver is an integral part of the display so you can monitor your heart rate while exercising. If you wear a chest strap, your heart rate (beats per minute) appears on the display.

The Precor web site (www.precor.com) has several suggestions for workouts with varying levels of intensity. It provides many workout details that include the appropriate target heart rate.

The cycle includes a heart rate program that lets you exercise based on a specified target heart rate. As you exercise, the program monitors your heart rate and automatically maintains it within a few beats per minute of your selected target. To use this program, press the PROGRAMS - HEART RATE key. For more information, refer to *Programs*.

Heart Rate Analysis

Every time you complete a program using the chest strap, the display provides a heart rate analysis after the workout summary. The heart rate analysis is based on how often your heart rate signal is received while exercising.

Your average heart rate appears followed by the maximum heart rate achieved during your workout. A third display appears, if you entered your age, and indicates the amount of time your heart rate remained between the target zones shown.

Display Console

Center display: Initially shows the Precor banner. It changes to the program profile. A blinking column in the profile indicates your position. During an exercise session, additional information appears depending on program and user selections.

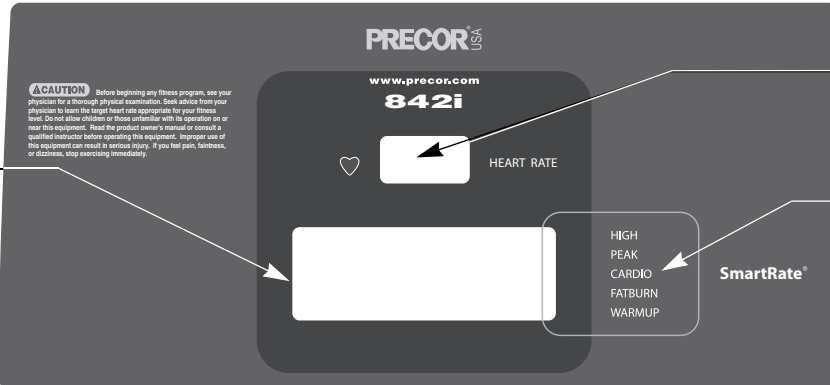

Heart Rate display: Your heart rate appears when you wear a chest strap. The heart rate indicator blinks in rhythm to your heart rate.

SmartRate display: The zone, that you are exercising in, appears when you enter your age after selecting a program, and wear a chest strap.

PROGRAMS keypad: To begin an exercise session, press the PROGRAMS keys to view a menu of programs within each category. For program descriptions, refer to Programs.

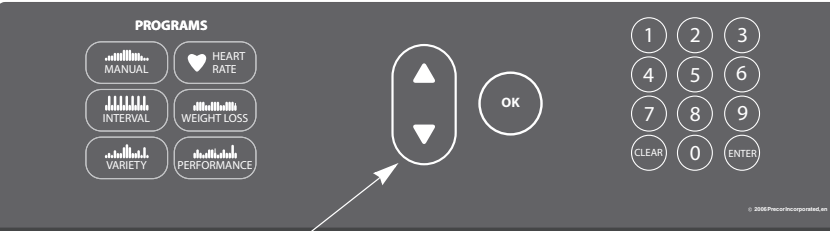

Number keys: During an exercise session, use the number keys to answer prompts or update information. If the entertainment option is attached, the number keys act as TV channel controls.

Navigational arrow keys: Lets you display exercise information prior to selecting it with the OK key.

Selection keys: Each key moves through the information in each column, choosing what you want to display during your session. Indicator lights appear next to the item that is displayed.

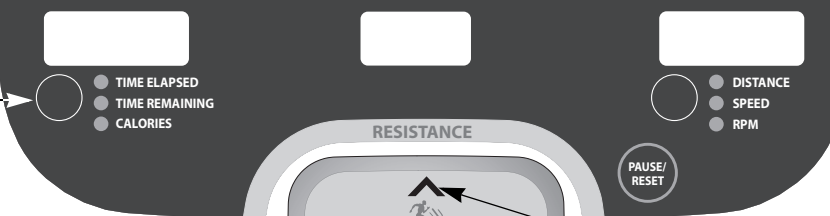

Lower display: While you exercise, three sets of numbers show information about your session.

QUICKSTART: Press QUICKSTART to begin your workout immediately.

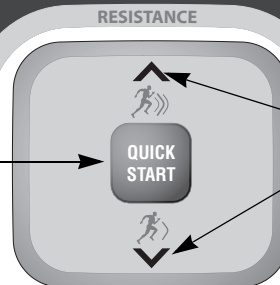

RESISTANCE arrow keys: Use the arrow keys to adjust the resistance.

More Information about the Center Display

The program profile appears during an exercise session in the center portion of the display. Your heart rate appears if you are using the chest strap. Refer to *Heart Rate Features*.

During a workout, the program profile raises or lowers according to which arrow key (▲ or ▼) is pressed. In most programs, the program profile is affected by the RESISTANCE arrow keys with the exception of the Basic HRC Program. The column height changes according to the settings shown in Diagram 4.

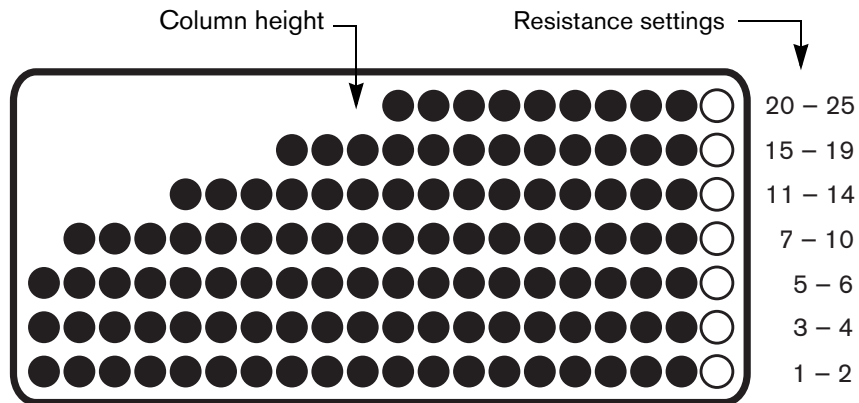

Diagram 4: Column height in the program profile

During an exercise session, the display becomes a message bar showing additional information depending on user selections and program interludes.

More Information about the Lower Display

The lower display provides information about your workout session. You can choose the type of information displayed in Column 1 and Column 3 by pressing the adjacent Selection key. The numbers that appear over each column of information relate to your workout statistics and are described below.

Note: If you choose to rest a book or magazine on the display, you can still view these workout statistics.

Column 1: TIME ELAPSED and TIME REMAINING

TIME ELAPSED—displays workout time in minutes and seconds and indicates the amount of time you have been exercising. When you exceed 60 minutes during a single workout, the TIME ELAPSED display converts to hours and minutes.

Note: The club can place limits on workout time.

TIME REMAINING—shows the amount of time remaining in a workout. If the selected workout time is less than 60 minutes, the display shows time in minutes and seconds. If you select a workout time greater than 60 minutes, the display reflects hours and minutes until the countdown reaches 60 minutes, at which time the display reverts to minutes and seconds.

CALORIES—indicates the estimated cumulative number of calories being burned.

Column 2: RESISTANCE

RESISTANCE—displays the resistance you feel while pedaling. The RESISTANCE arrow keys affect the brake and let you set a resistance between 1 and 25.

Column 3: DISTANCE, SPEED, RPM

DISTANCE—shows the linear distance in either miles or kilometers. The distance calculation is determined by the revolutions per minute.

SPEED—shows the “linear speed” even though the cycle is stationary. The value is determined by converting the current revolutions per minute and resistance setting. The calculation appears as miles per hour or kilometers per hour.

RPM—indicates the number of pedal revolutions completed per minute. The value can range between 20 and 150.

Keypads

Use the keypads to enter your workout session selections to affect what appears on the display and to establish the pedal resistance.

Four distinct keypads exist on the display and are discussed in this section:

- Lower Display keypad and the Selection keys
- Navigational keypad in the center of the display
- PROGRAMS keypad
- Number keypad with the ENTER and CLEAR keys

Lower Display Keypad and the Selection Keys

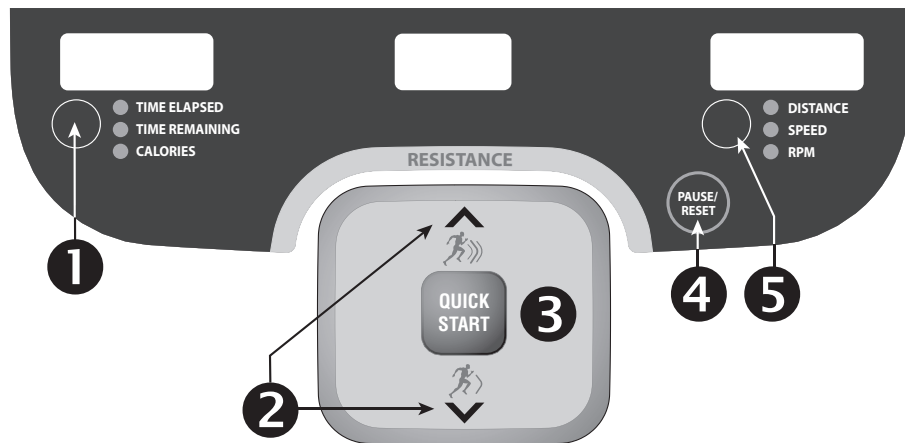

Diagram 5: Lower Display keypad and the Selection keys

- 1 Left selection key:** Every time you press this key, the display reflects either the amount of time elapsed since you began your exercise session, your time remaining, or your estimated number of calories burned. An LED lights and indicates which information is being displayed.
- 2 RESISTANCE:** Press and hold the RESISTANCE arrow keys to increase or decrease the resistance you feel against the pedals. The RESISTANCE arrow keys affect the brake and let you set a resistance between 1 and 25.

When you press the arrow keys, a target resistance appears in the display, but the change you feel in the pedal resistance occurs gradually so the transition is smooth.
- 3 QUICKSTART:** Press QUICKSTART to start your workout immediately using the Manual Program. Refer to *Choosing QUICKSTART*.

- 4 PAUSE/RESET:** Press this key to end the exercise session and view your workout summary. An exception to this rule exists if you have entered the 30-second shutdown period. When you press PAUSE/RESET, the display returns to the banner. Refer to *Pausing During a Workout or the Cool-Down Period*.
- 5 Right selection key:** Every time you press this key, the display reflects either the distance travelled since you began your exercise session, your speed, or the revolutions per minute (RPM). An LED lights and indicates which information is being displayed.

Navigational Keypad



Diagram 6: Navigational keypad

The navigational keypad provides several ways to change your exercise session and to display various workout statistics. The OK key, which allows you to confirm display selections, is also part of the navigational keypad.

OK: Use the OK key to confirm responses to specific prompts.

Up and Down Arrows: These up and down arrows present the available selections and affect what appears on the display.

PROGRAMS Keypad

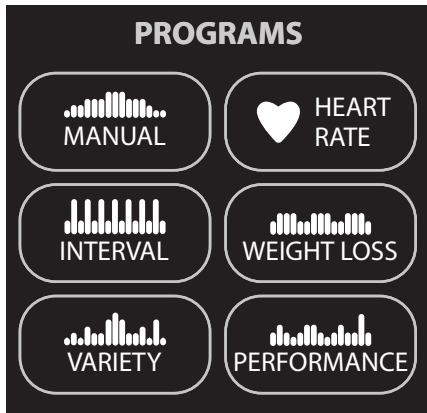

Diagram 7: PROGRAMS keypad

The PROGRAMS keypad provides access to all the exercise programs. Choosing a category and pressing the associated PROGRAMS key, accesses the menu selections. Refer to Table 2. For a description of each program, refer to *Programs*.

Note: Use the OK key to confirm your selection. For more information, refer to *Workout Options*.

Table 2. Available programs

<i>PROGRAMS</i> key	<i>Program Menu</i>
MANUAL	Manual
INTERVAL	Interval
VARIETY	Random
HEART RATE	Basic HRC*
WEIGHT LOSS	Weight Loss
PERFORMANCE	Hill Climb

* Use of a chest strap is required.

Number Keypad

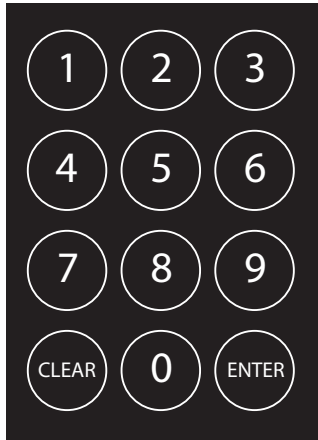

Diagram 8: Number keypad

The number keypad has several functions depending on what is connected to the cycle.

Connection	Description
Entertainment Option	If an entertainment option is connected to the display, the number keypad acts as a remote control which you use to select the available channels. You can also enter number values in answer to exercise session prompts.
Nothing	Whether or not peripheral devices are attached to the unit, the keypad lets you enter number values in answer to exercise session prompts. You need to press ENTER or OK to confirm the selection.

The CLEAR and ENTER keys provide the following functions:

CLEAR: Use the CLEAR key to remove the last number being displayed.

ENTER: Use the ENTER key to accept the number being displayed.

Note: The OK and ENTER keys are usually interchangeable and provide the same function when no peripheral devices are attached to the cycle. peripheral connection, use the ENTER key.

Workout Options

CAUTION: Before beginning any fitness program, see your physician for a complete physical examination. Know your physician-recommended heart rate target zone.

1. Sit on the seat and place your shoes inside the pedal straps.
2. When you are comfortably situated, begin pedaling.

3. Select one of the following options:

<i>Option...</i>	<i>Steps...</i>
To start exercising immediately	<ul style="list-style-type: none">• Use the QUICKSTART key.• Refer to <i>Choosing QUICKSTART</i>.
To select a program	<ul style="list-style-type: none">• Press a PROGRAMS key.• Refer to <i>Selecting a Program</i>.

Note: The QUICKSTART key is disabled when you press a PROGRAMS key. You need to confirm each workout session selection (program, workout time, weight, and age) using the OK key.

Choosing QUICKSTART



1. While the Precor banner scrolls, press QUICKSTART to begin the Manual Program.

QUICKSTART applies the following defaults:

Prompts	Default Value
Program	Manual
Time	Club setting
Weight	150 lb (68 kg)
Age	0

2. Use the RESISTANCE arrow keys to change the resistance.

3. Maintain a consistent pedaling speed while exercising. Find a comfortable pedaling speed between 20 and 150 revolutions per minute.

To use the SmartRate feature, you need to specify your age and wear a chest strap. In this case, press MANUAL, as the Precor banner scrolls, and follow the prompts to address your weight and age. You can use the number keypad to change the blinking prompts. Refer to *Selecting a Program*.

Selecting a Program

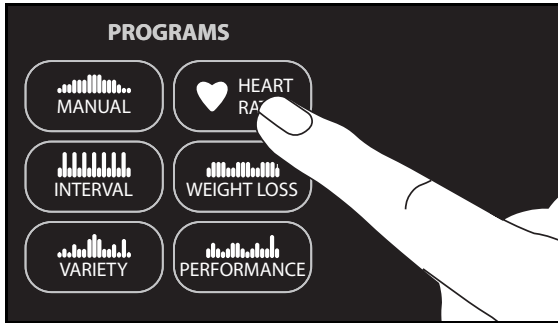

1. While the Precor banner scrolls, press a PROGRAMS key and then, press OK.
2. A workout time blinks in the center display. Use the navigational arrow keys or the number keys to adjust the minutes (1 - 60) and then press OK.

Note: The workout time prompt is skipped if you press the WEIGHT LOSS key.

You may be able to exercise indefinitely in any program (except Weight Loss). Once you select a program, a workout time blinks in the center display. Press the number 0 and then press OK. If you choose this option, the automatic cool-down period is eliminated. You will need to incorporate a cool-down period by accessing the Manual Program.

Note: The club can set limits for workout, pause, and cool-down times. So, selecting an unlimited workout time may not be allowed. Check with your club or facility manager.

3. Enter your weight (1 - 999) and then your age (1 - 99).

Note: To change a value (program, workout time, weight, or age) that you have already entered, continue pedaling and press PAUSE/RESET to return to the Precor banner. Select a program and reenter the appropriate values.

4. Maintain a consistent pedaling speed while exercising. Find a comfortable pedaling speed between 20 and 150 revolutions per minute.
5. Use the RESISTANCE arrow keys to change the resistance. The program profile changes accordingly.

Changing Programs in Mid-session

You can change programs in the middle of a session by selecting a new program from the PROGRAMS key menu and pressing OK. All accumulated workout statistics are transferred to the new program as you continue exercising.

Note: You cannot select a different program if you are in the cool-down period or if you stop pedaling and the cycle begins its 30-second shutdown. Refer to *Pausing During a Workout or the Cool-Down Period*.

Certain programs, such as Basic HRC and Weight Loss, are not available for mid-session transfers due to set goals and program preferences. If this occurs, a message scrolls across the center display.

Cooling Down After a Workout

Incorporate a cool-down period into your workout to help lower your heart rate and minimize muscle stiffness or soreness.

When you complete a program with a time limit or specified goal, you automatically enter a cool-down period. The resistance is reduced by 20%. To adjust the resistance, press the arrow keys.

Note: You cannot switch to a different program during the cool-down period. Any pressure on the PROGRAMS keys are ignored.

A workout summary appears at the end of the cool-down period. Refer to *Ending a Workout*.

A cool-down period will not be appended to your workout session if the following occurs:

- The club allows the NO LIMIT option for a user's workout time and, you enter a time goal of zero, essentially setting an unlimited workout time.
- The club sets a cool-down time of zero, which eliminates the cool-down phase.
- You exit a program before completing it.

If you specify an unlimited workout time or the club removed the cool-down phase, remember to incorporate a cool-down period at the end of your workout.

Pausing During a Workout or the Cool-Down Period

If you stop pedaling anytime during a workout or during a cool-down period, the cycle begins a 30-second shutdown. You cannot pause for a longer period of time or change to a different program unless the club has the optional power adapter attached to the unit.

When the optional power adapter is attached, you can pause for a set time, usually two minutes. If you do not resume pedaling during that time, the display returns to the banner.

1. To pause, stop pedaling.
2. To resume exercising from pause mode, begin pedaling.

Note: In pause mode, you have the ability to change your program selection. Refer to *Changing Programs in Mid-session*.

Ending a Workout

CAUTION: Hold on to a handlebar when you near the end of your exercise session.

1. You can slow your pedaling when you complete the cool-down period, but maintain, at minimum, 20 revolutions per minute to view your workout summary.

The workout summary appears and shows your cumulative workout statistics including warm-up and cool-down periods. You can review your workout statistics as long as you continue pedaling.

2. While **WORKOUT SUMMARY** scrolls across the display, press the left selection key to highlight **CALORIES**. The **CALORIES** display shows the estimated calories burned during your exercise session. To view your cumulative distance, highlight **DISTANCE** using the right selection key.
3. End your workout by pressing the **PAUSE/RESET** key and return to the Precor banner.
4. Stop pedaling.
5. Hold on to a handlebar as you dismount.

Note: If the optional power adapter is attached, you do not have to continue pedaling to view your workout statistics. When you complete the cool-down period, the workout summary appears. Press **PAUSE/RESET** again to return to the Precor banner.

If you wear a chest strap while exercising, a heart rate analysis appears during the workout summary. Refer to *Heart Rate Analysis*.

Programs

This section describes the programs available on the C842i Upright and Recumbent Cycles. Use this section as a reference tool to better understand each program's purpose.

Choosing a Program

Choosing a program depends on your goals. If you are a beginner or returning to regular exercise, you can start a cardio-conditioning program to slowly return your body to a comfortable level of exercise. If you have been exercising and feel that you have an intermediate or advanced fitness level, you probably have established goals. The Precor web site (www.precor.com) can give you many ideas about fitness routines and advice from the experts.

Several exercise choices on the cycle are preprogrammed with recommendations for resistance and alternating rest or work intervals. You always have the option to override the suggested levels with the exception of the Basic HRC Program.

If your level of exertion becomes too great, reduce your pedaling speed or use the RESISTANCE arrow keys to override each upcoming column in the program profile. If you use the arrow keys, the profile changes accordingly.

Program Tips

- While exercising, you need to pedal above 20 revolutions per minute (RPM). Dropping below 20 RPM causes the cycle to shut down to conserve battery power. The cycle displays a 30-second countdown before it shuts off. If you move the pedals during the countdown period, you can resume exercising where you left off.
- Begin at the Precor banner and choose a program by pressing PROGRAMS or QUICKSTART. Refer to *Workout Options*.
- A blinking column indicates your position as you progress through a program.
- To use the SmartRate feature, you need to specify your age through the program selection process and wear a chest strap.
- The club can set limits on workout, pause, and cool-down times. Check with your club or facility manager to learn if any club limits are in place that might affect your program selections.

Manual Program



The Manual Program profile, available by pressing the MANUAL key, begins as a flat line. You control resistance settings using the RESISTANCE arrow keys. The program profile reflects any changes. The blinking column indicates your position in the program.

The workout time reflects the club default setting. A cool-down period occurs automatically when you end your workout.

Note: An exception to the cool-down period exists if the club allows it. Refer to *Cooling Down After a Workout* for more information.

To use the SmartRate feature, you need to specify your age by accessing the Manual Program through the PROGRAMS key.

Interval Program



The Interval Program, available by pressing the INTERVAL key, is among the best for conditioning your cardiovascular system. The program raises and lowers your level of exertion repeatedly for the specified period of time.

When you begin the program, the resistance for the rest and work intervals is preprogrammed. The settings are repeated throughout the program unless you change them.

To change the settings, press the appropriate RESISTANCE arrow key and continue. The changes are applied to the remaining intervals. The display lets you know when the resistance is about to change, and indicates the level of the next interval.

Random Program



Everytime the Random Program is selected, by pressing the VARIETY key, a different program profile appears. The columns that appear in the program profile show the preprogrammed resistance. To override the settings for each column, press the RESISTANCE arrow keys. The changes raise or lower the columns on the remaining portion of the program profile.

The resistance is preset to 1 for the first column. The maximum resistance change allowed between columns is plus or minus 4.

Basic HRC Program



The Basic Heart Rate Program, available by pressing the HEART RATE key, lets you set a target for your heart rate. The program adjusts the resistance to maintain your heart rate within two beats per minute of the target heart rate while you exercise. To use this program, you must enter your age and wear a chest strap so your heart rate can be monitored throughout the session.

Important: Consult your physician to determine the appropriate target heart rate for your age and fitness level. If your physician recommends a different target heart rate than the one that appears on the display, use the navigational arrow keys to change the target heart rate once you finish the warm-up period. Do not exercise over the recommended range.

Basic HRC Program Tips

The Basic HRC Program enhances your overall cardiovascular fitness levels to help you achieve your weight loss and fitness goals. Read through the following tips before selecting the Basic HRC Program. These tips provide general information regarding how the program functions. For more information and exercise suggestions, refer to the Precor web site at www.precor.com.

Important: Maintain a consistent pedaling speed between 20 and 150 RPM. Automatic adjustments to the resistance cannot take place if you drop below 20 RPM.

- The workout time is set to the club limit. To adjust the time, select a different time at the blinking time prompt. You can use the number keys followed by OK to change the workout time.

- The program provides a 3-minute warm-up period. During this time, you may change the resistance.

Note: When your target heart rate is achieved or the 3-minute period elapses, the warm-up period ends and the program begins.

- The program automatically adjusts the resistance to keep your heart rate at the selected target. After the warm-up period, pressing the RESISTANCE arrow keys no longer affects the resistance. Check the SmartRate display to see if you are maintaining your preferred zone. Check the HEART RATE display to determine your actual heart rate. For information about understanding your target heart rate, refer to *Heart Rate Features*.
- You can change the target heart rate or your RPM, but doing so affects the unit's ability to maintain your target heart rate in the preferred zone. It takes time for the cycle to readjust the resistance so that your heart rate remains on target.
- If you wish to quit the Basic HRC Program, you can make a mid-session transfer to another program, but you cannot return or transfer mid-session to the Basic HRC Program.
- A cool down period is automatically added to the end of the program.

If you are having difficulty with the heart rate features, talk to your club or facility manager.

Weight Loss Program



With the Weight Loss Program, the workout time is fixed at 28 minutes and consists of seven 4-minute intervals. You are not prompted for a workout time. Use the arrow keys to change the resistance for the rest or work interval. When you make changes, the program repeats the settings for the remaining intervals.

The display lets you know when the resistance levels are about to change.

Note: You cannot transfer mid-session to the Weight Loss Program.

For the ideal weight loss range, your heart rate should remain between 55% and 70% of your maximum aerobic heart rate. If you wear a chest strap, you can use SmartRate as a visual cue.

- Set a comfortable pedaling speed and then adjust the resistance.
- Maintain a level of exertion so that the SmartRate LEDs in the FATBURN target zone blink in the display during the rest intervals.
- During the work intervals, increase your level of exertion so that the LEDs in the CARDIO target zone blink.

For more information about the SmartRate display, refer to *Using SmartRate*.

Hill Climb Program



The Hill Climb Program, available by pressing the PERFORMANCE key, is a variable resistance program that works several different muscle groups. The resistance in the Hill Climb Program is preprogrammed. To override the resistance settings for each column, press the RESISTANCE arrow keys. The changes raise or lower the columns on the remaining portion of the program profile.

Notes:

C842i Commercial Cycles

Product Specifications

	C842i Upright	C842i Recumbent
Length:	54 in (137 cm)	56 in (142 cm)
Width	24 in (62 cm) ¹	24 in (62 cm)
Height	59 in (150 cm)	49 in (125 cm)
Weight	147 lb (67 kg)	195 lb (88 kg)
Shipping weight	154 lb (70 kg)	205 lb (93 kg)
Power	Self-powered	Self-powered
Resistance levels	1–25	1–25
Frame	Powder-coated steel	Powder-coated steel
Regulatory Approvals	FCC, ETL, CE	FCC, ETL, CE

Product Features

Entertainment Option Available
Heart Rate Telemetry*
QuickStart™
SmartRate®

Programs

Manual
Interval
Variety
Random
Heart Rate
Basic HRC*
Weight Loss
Weight Loss
Performance
Hill Climb

Electronic Readouts

% Complete
Average Heart Rate*
Average Speed
Calories
Distance
Heart Rate*
Language
Maximum Heart Rate*
Profile
Resistance Levels
RPM
SmartRate*
Speed
Target Heart Rate
Time
Time Elapsed
Time in Heart Rate Zone*
Time Remaining
Units
Workout Summary

^s Use of a chest strap is required.

Precor, C, CrossRamp, EFX, M, Move Beyond, and SmartRate are registered trademarks of Precor Incorporated. Crosstrainer, QuickStart, and StretchTrainer are trademarks of Precor Incorporated. Copyright 2006 Precor Incorporated. Specifications subject to change without notice. www.precor.com

NOTICE:

Precor is widely recognized for its innovative, award winning designs of exercise equipment. Precor aggressively seeks U.S. and foreign patents for both the mechanical construction and the visual aspects of its product design. Any party contemplating the use of Precor's product designs is hereby forewarned that Precor considers the unauthorized appropriation of its proprietary rights to be a very serious matter. Precor will vigorously pursue all unauthorized appropriation of its proprietary rights.

PRECOR^{USA}
move beyond®

Precor Incorporated
20031 142nd Ave NE
P.O. Box 7202
Woodinville, WA USA 98072-4002



C842i URM 49335-102, en
14 August 2006

Assembly Guide



C846i

PRECOR[®]
USA
move beyond[®]

C842i

C846i

Commercial Upright Cycle

Thank you for choosing Precor. For proper installation, please read this guide thoroughly and follow the assembly instructions. If you do not assemble the cycle according to these guidelines, you could void the Precor Limited Warranty.

Obtaining Service

You should not attempt to service the cycle except for maintenance tasks as described in the *Product Owner's Manual*. If any items are missing, contact your dealer. Should you need more information regarding customer support numbers or a list of Precor authorized service centers, visit the Precor web site at www.precor.com/corp/contact.

Unpacking the Equipment

Ask for help from two or more people to unpack and assemble the cycle.

Required Tools

- Wire tie cutter
- Phillips-head screwdriver
- One ¾-inch combination wrench (box-end or crescent)

Cardio Theater PVS Assembly Instructions



If the Cardio Theater Personal Viewing System (PVS) accompanies this Precor unit, review the PVS assembly instructions found in the Cardio Theater box. Alleviate additional assembly or disassembly steps by combining the two assemblies as needed.

Installation Requirements

Follow these installation requirements when assembling the unit:

- **Assemble the unit near the location where you plan to use it.**
- **Provide ample space around the unit.**
Open space around the unit allows for easier access.
- **Set up the unit on a solid, flat surface.**
A smooth, flat surface under the unit helps keep it level. A level unit has fewer malfunctions.
- **Open the box and assemble the components in the sequence presented in this guide.**
- **Insert all fasteners with your fingers.**
Use your fingers to properly align and thread the fasteners. This helps alleviate cross-threading. Do not fully wrench tighten fasteners until instructed to do so.
***Important:** When wrench tightening, the head of the fastener should be flush with the product. If it is not, cross-threading has occurred. Do not attempt to rework the assembly as more damage to the equipment will occur. Contact Customer Support. Refer to Obtaining Service.*
- **If you plan to move the unit, obtain help and use a hand truck.**
Do not grasp any plastic parts while lifting or moving the unit. The plastic parts are not capable of supporting the weight of the unit and they may break.

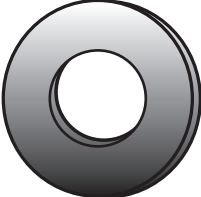
Hardware Kit (not to scale)

Fasteners		Quantity
	(A) Hex head cap screw (5-inch)	2
	(B) Washer (1/2-inch)	2
	(C) Buttonhead screw (1 3/4-inch) <i>Important: You can discard the buttonhead screws because they are not used in this assembly.</i>	4
	(D) Phillips-head screw (3/4-inch)	3

1 – Rubber bib (E)

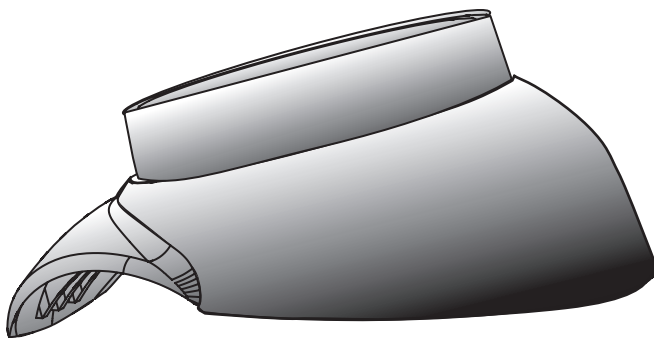

Assembly Steps

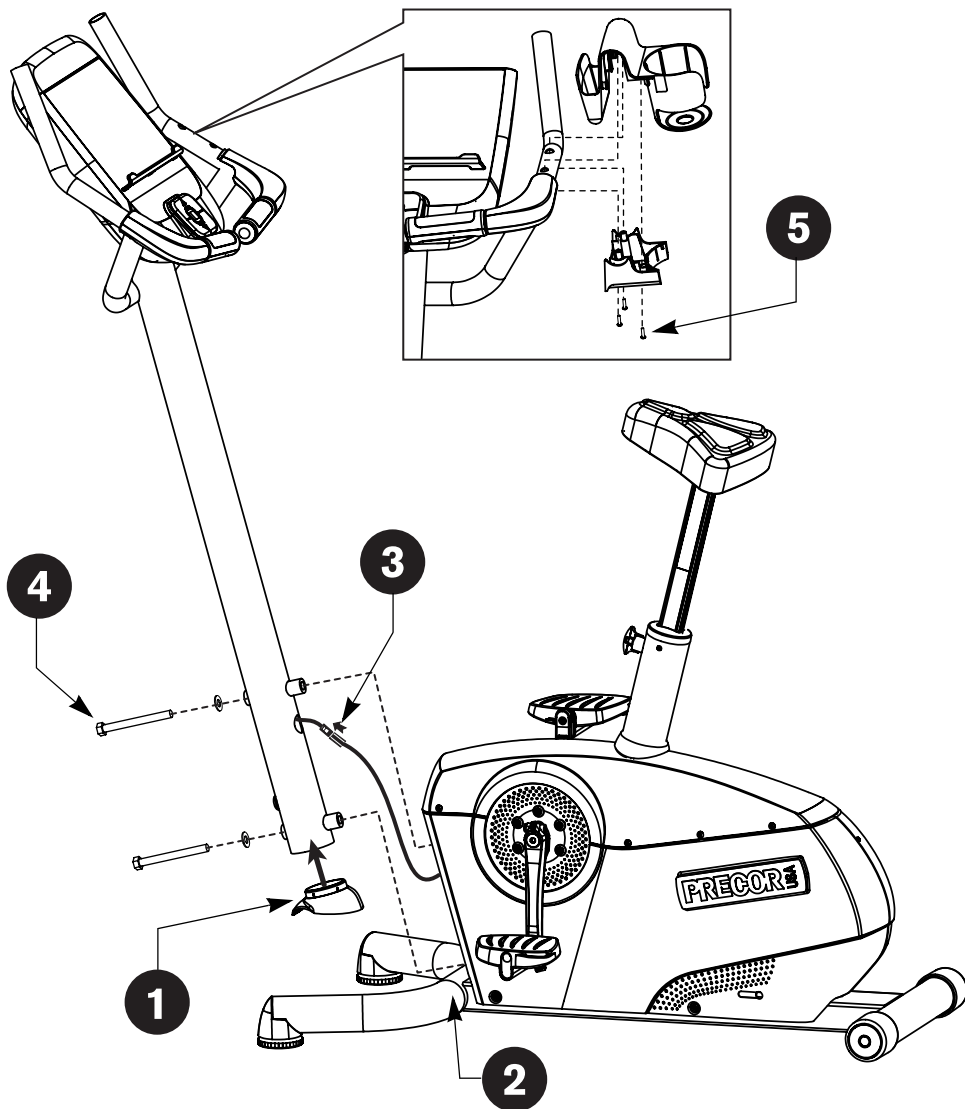

- 1 Position the rubber bib (E) so the flared side faces the floor (as shown in the illustration) and slide it into the base of the upright support.
- 2 Place the upright support on the base crossbar so that the lip of the rubber bib rests on the crossbar and is parallel to the floor.
- 3 Have your assistant hold the upright support while you connect the cable. Place excess cable inside the base assembly.

Important: Do not stretch, crimp, or damage the cable. Any cable damaged by improper installation will not be covered by the Precor Limited Warranty.

CAUTION: Before tightening the screws, make sure the cable is not in danger of being crimped or pinched.

- 4 Secure the upright support to the base assembly using two hex head cap screws (A) and two washers (B). Alternately tighten each screw using a $\frac{3}{4}$ -inch box-end or crescent wrench. Check the upright support to make sure it is securely fastened.
- 5 Position the water bottle holder as shown and attach it to the right handlebar. Secure the holder using three Phillips-head screws (D) and a Phillips-head screwdriver.

6

Adjust the seat. Pull up on the seat to raise it. To lower the seat, hold onto the seat pad while you pull out the pop pin. Slide the seat into position and reinsert the pop pin.

CAUTION: Always apply downward pressure to the upright cycle seat to make sure it is securely in place before a user sits on the seat.

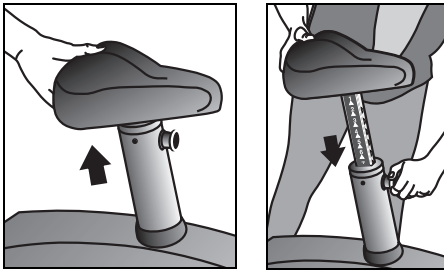

7

Level the cycle.

Before allowing users on the cycle, make sure it does not wobble from side to side.

To remove any side-to-side movement, take the following steps.

1. Ask your assistant to tip the unit on its side.
2. Locate the two height adjusters at the front of the unit.
3. Rotate the height adjusters to raise or lower the unit.

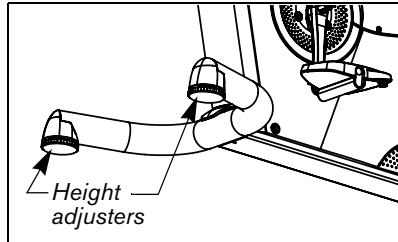

Important: If the unit is placed on a slightly uneven surface, rotating the height adjusters can help, but will not compensate for extremely uneven surfaces.

4. When you are finished adjusting the cycle, ask your assistant to gently lower the unit to the floor.

8

Verify that the C846i heart rate display is operational.

Note: To check the heart rate display on the C842i, you need to wear a chest strap and skip step 2.

1. Sit on the cycle. When you are comfortably situated, begin pedaling. Pedaling above 20 revolutions per minute (RPM) must be maintained for several seconds.
2. Grasp both touch-sensitive handlebar grips.
3. Look at the HEART RATE display. After a few seconds, a number appears indicating your heart rate.

Note: If a number does not appear in the HEART RATE display, you may need to disassemble the unit and check the cable connection. For troubleshooting tips, refer to the *Product Owner's Manual*.

PRECOR[®]USA
move beyond[®]

Precor Incorporated
20031 142nd Avenue NE
P.O. Box 7202
Woodinville, WA USA 98072-4002



©2007 Precor Incorporated
www.precor.com
C846i/C842i Upright AG 49101-103, en
19 February 2007