



Precision Electronic  
Treadmill\*

\*Several versions of this owner's manual exist. This is a copy of the last version published. If the assembly instructions do not coincide with your treadmill, please call Precor Customer Service.

# Owner's Manual

**PRECOR**<sup>®</sup> USA

# IMPORTANT SAFETY INSTRUCTIONS

When using an electrical appliance, basic precautions should always be taken, including the following:

- Read all instructions before using the M9.1 or M9.2s Precision Electronic Treadmill. These instructions are written to ensure your safety and to protect the treadmill.

Before beginning any fitness program, you should obtain a complete physical examination by your physician.

*Il est conseillé de subir un examen médical complet avant d'entreprendre tout programme d'exercice. Si vous avez des étourdissements ou des faiblesses, arrêtez les exercices immédiatement.*

## DANGER

To reduce the risk of electrical shock always unplug the M9.1 or M9.2s Precision Electronic Treadmill from the electrical outlet immediately after using and before cleaning.

## WARNING

To reduce the risk of burns, fire, electric shock, or injury to persons, take the following precautions:

- When it is plugged in, do not leave the M9.1 or M9.2s treadmill unattended. Unplug the treadmill from the power source when it is not in use, and before putting on or taking off parts.
- Close supervision is necessary when the M9.1 or M9.2s is used by, on, or near children, invalids, or disabled persons.
- Use the M9.1 or M9.2s treadmill only for its intended use as described in this manual. Do not use accessory attachments that are not recommended by the manufacturer—such attachments might cause injuries.
- Never operate the treadmill if it has a damaged cord or plug, if it is not working properly, if it has been dropped or damaged, or dropped in water. Return the treadmill to a service center for examination and repair.
- Turn OFF and unplug the treadmill when adjusting or working near the rear roller. Do not make adjustments to the running belt when someone is standing on the unit.
- Keep the power cord and plug away from heated surfaces.
- Never drop or insert objects into any opening. Keep hands away from moving parts.
- Do not use outdoors.
- Do not operate where aerosol (spray) products are being used or where oxygen is being administered.
- To disconnect, turn the power switch to the OFF (O) position, then remove the power plug from the wall outlet.

## WARNING

Connect the M9.1 or M9.2s to a properly grounded outlet only. See *Grounding Instructions*.

**SAVE THESE INSTRUCTIONS**

## Personal Safety

- Always attach the safety clip to your clothing at waist level prior to beginning your workout. The safety clip is connected by a cord to the magnetic safety key in the electronic console. If you encounter difficulties, you can stop the running belt by pulling on the cord to disengage the magnetic safety key from inside the console. To resume operation, the magnetic safety key must be replaced.
- When the treadmill is not being used, remove the magnetic safety key and store it in a safe place to prevent unauthorized use.
- Check the M9.1 or M9.2s treadmill before each use. Completely assemble the treadmill before using it.
- Assemble and operate the M9.1 or M9.2s on a solid, level surface. Locate the treadmill at least 4 feet from walls or furniture. Keep the area behind the treadmill clear.
- Wear proper exercise clothing and shoes for your workout—no loose clothing. Do not wear shoes with heels or leather soles. Check the soles of your shoes and remove any dirt and embedded stones. Tie long hair back.
- Keep all loose clothing and towels away from the running surface. The running belt will not stop immediately if an object becomes caught in the belt or rollers.
- Use care when getting on or off the treadmill. Use the handrails whenever possible. Step onto the running belt when the speed is at or below 1 mile per hour (1.6 kilometers per hour). Never step off the treadmill while the running belt is moving.
- Before the running belt begins moving (prior to your workout), and after it stops (at the end of your workout), straddle the belt by placing your feet firmly on the right and left side platforms.
- Never turn ON the treadmill when someone is standing on the machine.
- Keep your body and head facing forward. Never attempt to turn around on the treadmill when the running belt is moving.
- Do not rock the unit. Do not stand or climb on the handrails, electronic console, or hood.
- Keep all electrical components, such as the motor, power cord, and ON/OFF switch, away from water or other liquids to prevent shock. Do not set anything on the handrail, electronic console, or hood. Never place liquids on any part of the unit.
- Do not attempt to service the M9.1 or M9.2s treadmill yourself other than the assembly and maintenance instructions found in this manual. The M9.1 or M9.2s treadmill is for household use only. See *Obtaining Service* in the maintenance section of this manual.
- Do not overexert yourself or work to exhaustion.
- Stop your workout immediately if you feel any pain or abnormal symptoms, and consult your physician.

## Precor Smart Weights—Safety Guidelines

The Precor Smart Weights were created and designed exclusively for Precor products. Please take time to read the following guidelines:

- Handle Precor Smart Weights with care. Do not drop the equipment. It might damage the weights and you could void the manufacturer's limited warranty.
- Keep the equipment dry. Do not immerse the equipment in water.
- With every use, check that the remote signal is working before you begin your workout. After extensive use, the battery in the remote head may wear out. See *Replacing the Battery* in your Precor Smart Weights Owner's Manual.

Precor treadmills are designed for the enjoyment of the serious runner as well as the dedicated walker. By following the above precautions and using good common sense, you will have many safe and pleasurable hours of healthful exercise with your Precor treadmill.

## Information Regarding International Use

### FCC Communications Commission, part 15

The M9.1 or M9.2s treadmill has tested and it complies with the limits for a Class B digital device, pursuant to part 15 of the FCC Rules. These limits are designed to provide reasonable protection against harmful interference in a residential installation. The M9.1 or M9.2s treadmill generates, uses, and can radiate radio frequency energy and, if not installed and used in accordance with the owner's manual instructions, may cause harmful interference to radio communications. However, there is no guarantee that interference will not occur in a particular installation.

If the M9.1 or M9.2s treadmill does cause harmful interference to radio or television reception, which can be determined by turning the M9.1 or M9.2s treadmill OFF and ON, you are encouraged to try to correct the interference using one or more of the following measures:

- Reorient or relocate the receiving antenna for your TV, radio, VCR, etc.
- Increase separation between the M9.1 or M9.2s treadmill and the receiver (TV, radio, etc.).
- Connect the M9.1 or M9.2s treadmill into a different power outlet—on a dedicated circuit different from the one used by the receiver (TV, radio, etc.). No other appliance should be plugged into the same power outlet that the treadmill is connected to.
- Consult your dealer or an experienced radio/TV technician for help.

### Canadian Department of Communications

"This digital apparatus does not exceed the Class B limits for radio noise emissions from digital apparatus set out in the Radio Interference Regulations of the Canadian Department of Communications."

"Le présent appareil numérique n'émet pas de bruits radioélectriques dépassant les limites applicables aux appareils numériques de la class B prescrites dans le Règlement sur le brouillage radioélectrique édicté par le ministère des Communications du Canada."

\*Indiquer seulement la classe du appareils numériques correspondent à l'application visée.

## Grounding Instructions

The M9.1 or M9.2s Precision Electronic Treadmill must be grounded. If it should malfunction or break down, grounding provides a path of least resistance for electric current which reduces the risk of electrical shock. The treadmill is equipped with a power cord having an equipment-grounding conductor and a grounding plug. The plug must be inserted into an appropriate outlet that is properly installed and grounded in accordance with all local codes and ordinances.

## DANGER

Improper connection of the equipment-grounding conductor can result in a risk of electric shock. Check with a qualified electrician or service person if you are in doubt as to whether the treadmill is properly grounded. Do not modify the plug provided with the treadmill—if it doesn't fit the outlet, get a proper outlet installed by a qualified technician.

Diagram A

Proper grounding plug and power outlet for 120v connection

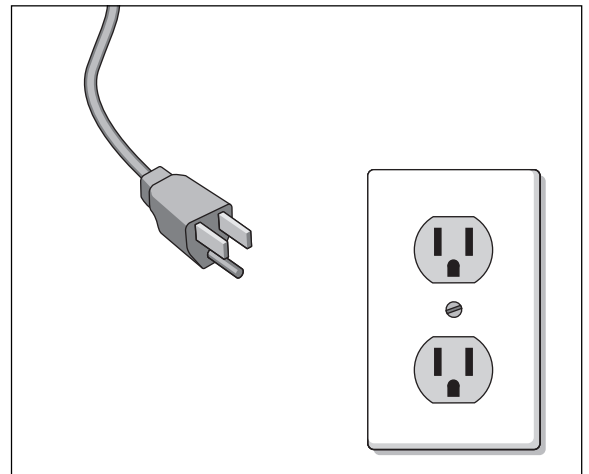

The treadmill is for use on a nominal 120-volt circuit (refer to the WARNING below and to the *Installation Requirements* on page 3) and has a grounding plug that looks like the plug illustrated in Diagram A.

## WARNING

This product is rated for **more** than 15 amps and is for use on a circuit having a nominal rating of 120 volts and is factory-equipped with a specific electric cord and plug to permit connection to a proper electric circuit. Make sure that the product is connected to an outlet having the same configuration as the plug. No adapter should be used with this product. If the treadmill must be reconnected for use on a different type of electric circuit, the reconnection should be made by qualified service personnel.

## ATTENTION: Haute Tension

Débranchez avant de réparer

## Table of Contents

	<b>Safety Information</b> .....	<b>ii</b>
	Important Safety Instructions .....	ii
	Personal Safety .....	iii
	Precor Smart Weight Option—Safety Guidelines .....	iii
	Information Regarding International Use .....	iv
	Grounding Instructions .....	v
<b>1</b>	<b>Before You Begin</b> .....	<b>1</b>
	Unpacking the Treadmill .....	1
	Optional Equipment: Smart Weights .....	1
<b>2</b>	<b>Setting Up the M9.1 or M9.2s Treadmill</b> .....	<b>3</b>
	Installation Requirements .....	3
	Assembly Instructions .....	3
	Checking the Alignment of the Running Belt .....	9
<b>3</b>	<b>Using the M9.1 or M9.2s Treadmill</b> .....	<b>10</b>
	Locating the ON and OFF Switch .....	10
	Using the Magnetic Safety Key .....	10
	Understanding the Electronic Console .....	11
	Displays on the Electronic Console .....	11
	Keys on the Electronic Console .....	12
	Changing the Display to U.S. Standard or Metric .....	13
	Selecting the TIME or DISTANCE prompt on the M9.2s .....	13
<b>4</b>	<b>Working Out on Your Treadmill</b> .....	<b>14</b>
	Changing Incline on the M9.1 .....	16
	Retrieving the Previous Workout Program .....	16
	Pausing Your Workout .....	16
	Cooling Down After a Workout .....	16
	Ending Your Workout .....	16
	Using the Manual Course Mode .....	17
	Changing the Interval Course Profile .....	17
	Using the M9.2s Preprogrammed Courses .....	18
<b>5</b>	<b>Getting the Most Out of Your Workout</b> .....	<b>20</b>
	How Hard Should I Exercise? .....	21
	How Long Should I Exercise? .....	22
	How Often Should I Exercise? .....	22
<b>6</b>	<b>Maintaining Your Treadmill</b> .....	<b>23</b>
	Cleaning the Equipment .....	23
	Aligning the Running Belt .....	23
	Adjusting the Tension of the Belt .....	24
	Servicing the Treadmill .....	25
	Power Cord Maintenance .....	25
	M9.1 and M9.2s Long Term Storage .....	25
	Obtaining Service .....	25

# 1

## Before You Begin

*This manual explains how to assemble, use, and maintain the M9.1 or M9.2s Precision Electronic Treadmill. The following conventions are used in this manual:*

**“Note:”** Contains additional information that applies to the preceding text.

**“Important:”** Indicates information to which you should pay special attention.

**“CAUTION:”** Indicates steps or information necessary to prevent harm to yourself or damage to the equipment.

**“WARNING:”** Provides instructions to prevent electrical damage to the equipment and prevent injuries to yourself or others.

**“DANGER:”** Indicates steps you must take to prevent electrical shock.

**CAUTION:** This unit weighs over 160 pounds. To avoid injury and to ensure the safety of the unit and yourself, get adequate assistance before dropping the sidewalls of the box and sliding the running bed assembly out of the box. Do not lift the running bed from the box.

Thank you for purchasing the Precor M9.1 or M9.2s Precision Electronic Treadmill. These treadmills feature one of the most sophisticated and beneficial technologies Precor has ever created: *Integrated Footplant Technology*.

Integrated Footplant Technology (IFT) is a microprocessor-regulated motor control system. This patented technology collects motor and belt speed data and uses it to monitor your workout and enhance your safety and comfort. It replicates the natural walking and running motion of your feet. By allowing slight, natural speed variations throughout your stride, Precor treadmills reduce shock and pounding to your body.

The easy-to-understand electronic console provides motivating feedback about your workout which includes: distance covered, elapsed time, current speed, calories burned, and percent of incline. On the M9.1, use the easy-to-reach incline crank handle on the console to change incline. On the M9.2s you can change inclines by pressing the INCLINE key on the electronic console. Inclines from 0 to 10 percent are available.

Two exercise modes come with the M9.1 treadmill: Manual and Interval. **Manual Mode** lets you control your workload throughout your workout session. In the **Interval Mode**, the treadmill reminds you to raise and lower the workload during your session in interval training fashion, helping you to achieve aerobic fitness in a shorter period of time.

Three different modes come with the M9.2s, **Manual**, **Interval**, (same as the M9.1) and **Program**. Program mode provides ten factory-programmed courses with predetermined inclines where you choose the speed and distance of your workout. All three modes provide variety to help entice and motivate you during your workout.

## Unpacking the M9.1 or M9.2s Treadmill

The M9.1 or M9.2s Precision Electronic Treadmill is intended for household use only and has many unique features which set it apart from conventional treadmills. To maximize your use of the treadmill, please study this manual thoroughly. Your treadmill is carefully inspected before shipment. Precor ships the unit in seven pieces as listed below:

- running bed assembly
- lift column assembly
- electronic console display
- owner’s manual, limited warranty card, and hardware kit (hardware kit shown in Diagram 1.)
- handrails
- lift column trim
- incline crank handle (**M9.1 only**)

Carefully unpack the pieces of the treadmill and lay them on the floor near the location where you plan to use the treadmill.

**Important:** If you have a **M9.2s**, do not cut the cable tie that runs through the elevation tube and the lift column. The elevation tube is calibrated at the factory and the plastic cable tie prevents excessive movement during shipment. While you are unpacking the treadmill, do not cut this cable tie. It will be cut, when you perform step 7 in the assembly process.

## Optional Equipment

- Precor Smart Weights™

The optional Precor Smart Weights are now available from your local dealer. Smart Weights can provide variety and intensity to your workout. Its remote capability allows you to work out with a combination of 1- or 2-pound hand weights and change the treadmill’s incline and speed, or stop the running belt, without ever touching the electronic console! Handrail carriers provide convenient locations to store your Smart Weights. Call your local dealer to find out about the details. To locate the dealer nearest you, call 1-800-4-PRECOR.

Diagram 1

Hardware kit

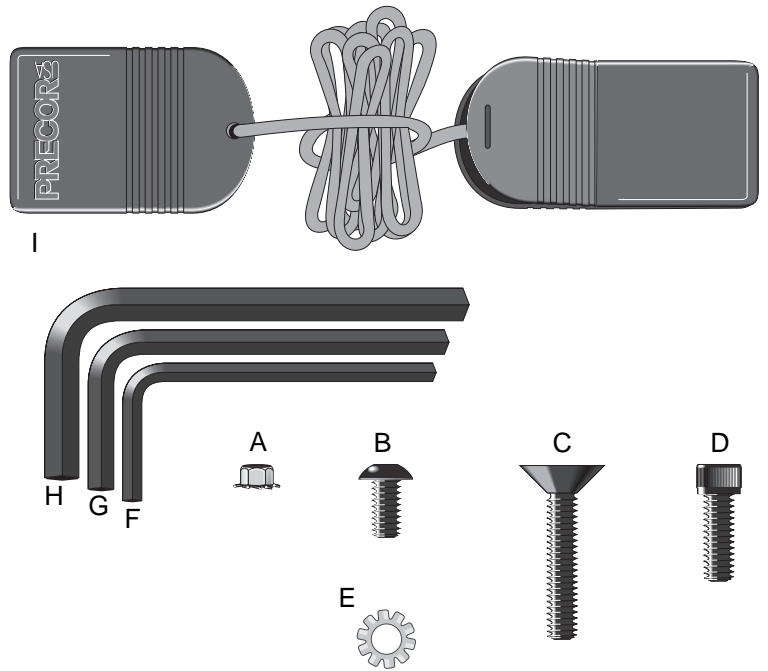

After unpacking the treadmill, open the hardware kit (refer to Diagram 1) and make sure that you have the following items:

- (A) Five flanged nuts — for installing the base plate
- (B) four upper handrail console screws
- (C) four upper handrail clamp screws
- (D) one crank handle screw (M9.1 only)
- (E) two external star washers — handrail clamp to column
- (F) one 5/32" hex key — upper handrail clamp and display console
- (G) one 3/16" hex key — crank handle and lower handrail clamp
- (H) one 1/4" hex key — belt tracking and tension adjustment
- (I) one magnetic safety key, cord, and clip

If any items are missing, contact the dealer from whom you purchased the treadmill, or call 1-800-4-PRECOR for the authorized Precor dealer nearest you.

**Important:** The packaging for this equipment was designed to protect it during shipment. If you plan on moving in the near future, please store the original packaging in a safe place.



# 2

## Setting Up the M9.1 or M9.2s Treadmill

You do not need any special knowledge or experience to set up the M9.1 or M9.2s treadmill. However, you must carefully review and follow the instructions in this manual. If you do not assemble and use this treadmill according to the following guidelines, you could void the Precor limited warranty.

### Installation Requirements

Follow these installation requirements when installing the treadmill:

- **Fill out and mail the limited warranty card.** The serial number is written on a label located underneath the treadmill on the left, rear corner of the running bed. The best time to locate and write the serial number onto the limited warranty card and in this owner's manual is while the treadmill is on its side during the assembly process. Refer to *Obtaining Service*, page 25.
- **Additional tools required.** To assist with the assembly process, acquire a 7/16" socket and ratchet with a 3" extension.
- **Set up the treadmill on a solid, flat surface.** Do not install the treadmill on deeply padded, plush, or shag carpeting due to possible damage to the carpet and machine. If the treadmill is placed on a carpeted surface, place a piece of heavy cardboard, plywood, or other smooth, flat surface under the unit to protect the carpet and treadmill. If the floor is not even, the running belt will not track properly. Refer to *Checking the Alignment of the Running Belt*, page 9.
- **Locate the treadmill at least 4 feet from walls and furniture.** Be sure to provide ample space in front of the machine to allow easy access to the ON/OFF switch. Open space to the sides and rear of the machine makes for a safer mount and dismount and easier belt adjustment.
- **Use a standard 120-volt household outlet.** Precor recommends that you plug your unit into a grounded outlet dedicated to a 20 amp house circuit breaker. The treadmill is equipped with a 20 amp circuit breaker to protect the electrical and electronic components from sustained overloads. An integral 3-prong plug protects the machine and is grounded for your safety.

**CAUTION:** Do not remove the 3-prong plug or otherwise bypass it with an adapter or extension cord in order to use a non-grounded outlet.

### Assembly Instructions

**CAUTION:** Do not try to assemble the treadmill by yourself. Because of the weight of the treadmill and its parts, get additional help before performing the following steps.

To assist you in the assembly of the treadmill, the items in the hardware kit, shown in Diagram 1, correspond to a particular letter in the alphabet. These letters appear throughout the assembly instructions. Refer to Diagram 1 while performing the steps below.

To assemble the M9.1 or M9.2s treadmill, take the following steps:

1. Locate the power switch at the front of the treadmill. Make sure that the power switch is in the OFF position and the treadmill's power cord is unplugged. Do not assemble the treadmill if it is plugged in and turned ON.
2. Obtain appropriate assistance to lay the treadmill on its left-hand side. Placing the foam blocks on the hood of the treadmill, as shown in Diagram 2 (on the next page), helps elevate the treadmill and keep pressure off the hood and side rail during assembly.

**Note:** Right and left are determined while standing to the rear of the treadmill facing toward the hood.

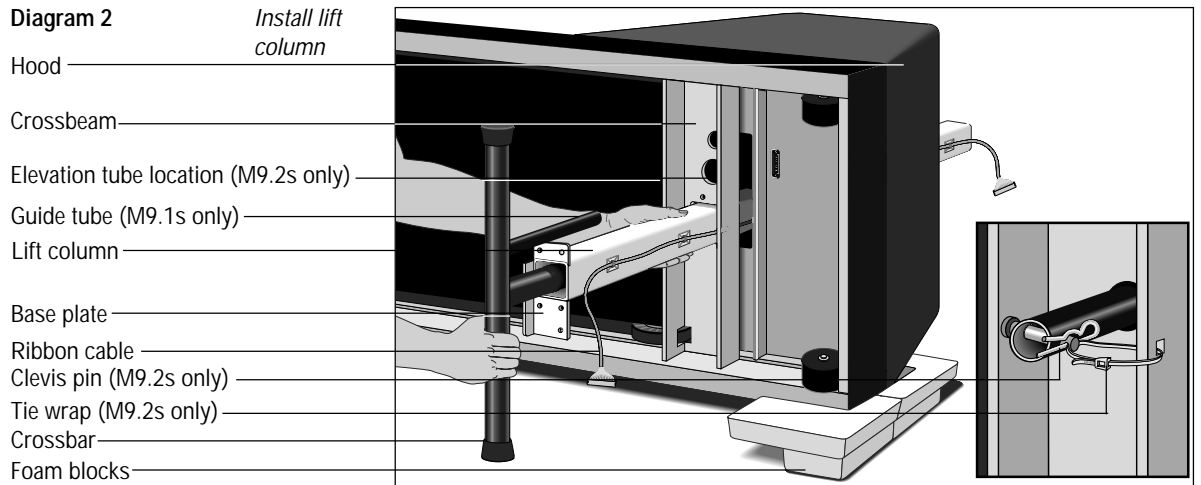

3. Pick up and rotate the lift column so that the crossbar is at a 90 degree angle to the base of the treadmill. The guide tube, **on the M9.1 only**, should align with the grommet hole in the crossbeam. Refer to Diagram 2. If necessary, remove the lower cable connector from inside the crossbar.
4. Slide the crossbar a few inches out of the lift column. Insert the top of the lift column into the crossbeam. Push the lift column through until the base plate is flush with the crossbeam. See Diagram 2. Have your assistant support the far end of the lift column.
5. Align the five holes in the lift column's base plate with the studs in the crossbeam. Have your assistant slide and hold the lift column into place while you put a flanged nut (A) on each of the five studs. Finger-tighten the nuts onto the studs.
6. Using your 7/16" socket wrench (a 3" extension ratchet is helpful), begin to tighten the flanged nuts. Alternate between each one, until the base plate is snug up against the crossbeam. Do not overtighten the nuts.
 

**Note — M9.1 owners:** Skip steps 7 and 8 if you have an M9.1 treadmill. Continue to step 9.
7. On the **M9.2s**, clip the tie wrap holding the clevis pin in the elevation tube. Remove the clevis and hitch pins. Due to the sensitivity of the lift calibrations, do not rotate the elevation tube more than 90 degrees in either direction.
8. Carefully align the mounting holes on the crossbar and elevation tube and slide the crossbar onto the elevation tube. Insert the clevis pin (head of the clevis pin should be toward the rear of the treadmill) through both holes and re-attach the hitch pin.

**Note:** The **M9.2s** lift is elevated to a 1 percent incline for ease of assembly. The functioning and accuracy the lift mechanism depends on properly installing the clevis and hitch pins.

Diagram 3

*Plug  
connector  
into lower  
board*

- Ribbon cable receptacle
- Ribbon cable connector
- Flanged nuts (A)
- Base plate
- Motor chassis
- Cross beam

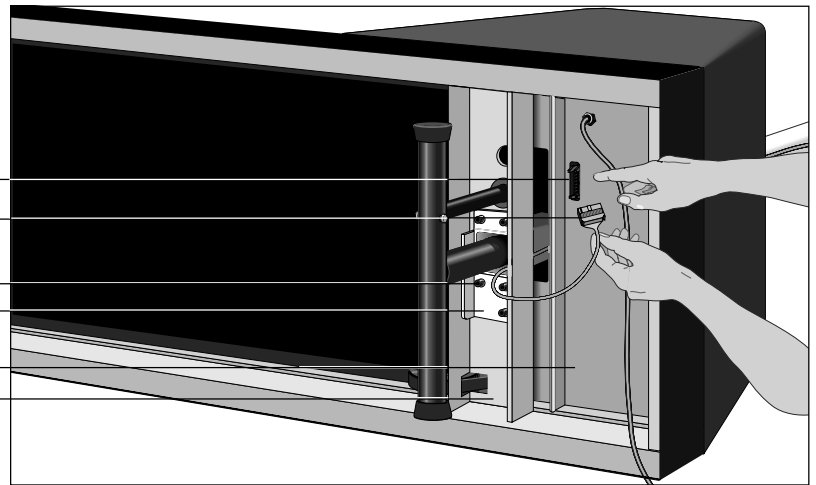

9. Route the ribbon cable as shown in Diagram 3, so that you have easy access to the receptacle on the motor chassis.
10. Align the tab on the ribbon cable connector with its counterpart located on the receptacle in the motor chassis. Plug the connector into the receptacle. See Diagram 3. The plastic flanges on the receptacle should clip onto the connector when you plug it in. Since the connector is designed to engage in one direction only, do not force the connector into the receptacle.
11. Have your assistants help you return the treadmill to an upright position, so that the base is flat on the floor.

Diagram 4

*Install upper  
handrail  
clamp*

- Handrail clamp
- External star washers (E)
- Handrail console screws (B)
- Lift column
- Ribbon cable
- Incline crank shaft (M9.1 only)

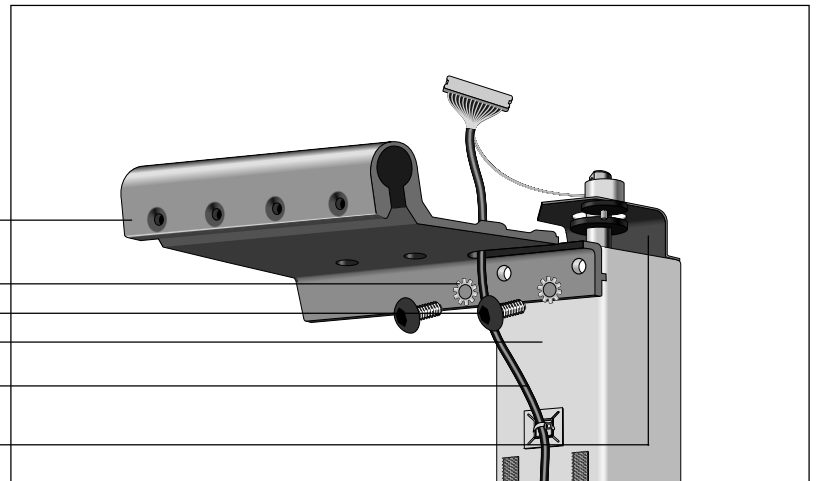

12. Place two external star washers (E) onto two of the upper handrail console screws (B) and align the upper handrail clamp with the mounting holes on the lift column. See Diagram 4.
13. Insert the screws (B) through the handrail clamp and into the lift column. Tighten the screws securely with the hex key (F) provided.
14. Carefully route the ribbon cable through the slot on the left-hand side of the handrail clamp.  
**Note:** Right and left are determined while standing to the rear of the treadmill facing toward the hood.
15. If your hands are dirty, wash your hands before continuing to the next step. This will help keep the electronic console display clean.

**Diagram 5**      *Attach cable to display*

Connector  
Plastic flange on receptacle

Ribbon cable  
Potentiometer cable (M9.1 only)

*Handrail clamp not shown*

Incline crank shaft (M9.1 only)

Lift column

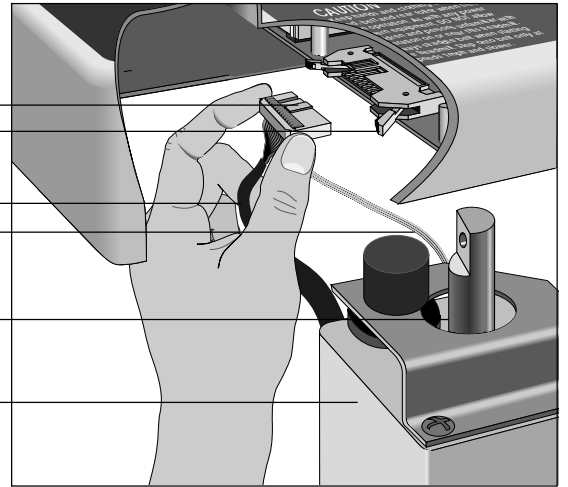

16. Hold the electronic console over the handrail clamp to attach the ribbon cable connector into its receptacle. On the **M9.1**, make sure that you hold the potentiometer cable away from the receptacle as you push the connector into place. See Diagram 5. Align the tab on the ribbon cable connector with its counterpart located on the receptacle and plug the connector into the receptacle using your fingers as shown in Diagram 5. The plastic flanges on the receptacle should clip onto the connector when you plug it in. The connector is designed to engage in one direction only. Do not force the connection.

If, at a later date, you need to disengage the connector, push the flanges off of the connector and use your fingers to pull the connector away from its receptacle.

**Diagram 6**      *Attach electronic console to handrail clamp*

Handrail clamp

Handrail console screws (B)

Electronic console

Ribbon cable

Lift column

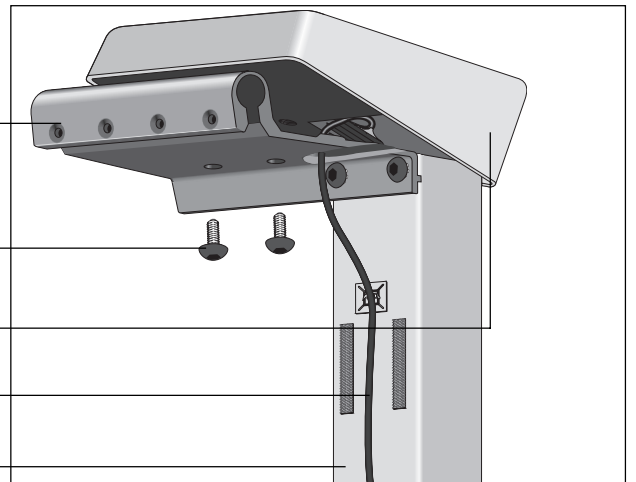

17. Align the electronic console mounting holes with the handrail clamp. Mount the electronic console onto the handrail clamp by inserting the two remaining handrail console screws (B). See Diagram 6. Insert the screws through the base of the handrail clamp and into the electronic console. Tighten the screws securely with the hex key (F) provided.
18. Carefully push the excess cable up inside the handrail console compartment. Check to be sure the cable forms a smooth loop. If the cable is pinched or damaged by improper installation, it will not be covered by the limited warranty.

**Note:** M9.2s owners skip to step 20.

Diagram 7

Install incline crank handle

Incline crank handle  
Incline handle screw  
Incline crank shaft

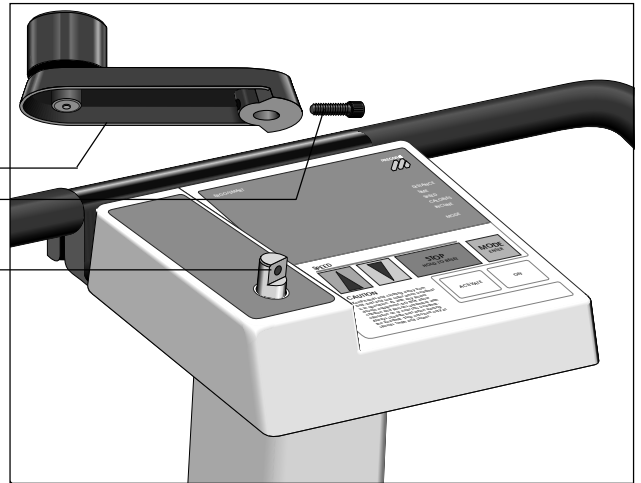

19. Install the incline crank handle (**M9.1 only**) onto the lift column shaft as shown in Diagram 7. Align the handle with the *flat* portion of the shaft end. Insert a screw (D) through the handle and crank shaft and tighten the screw securely with the hex key (G) provided. *Do not overtighten.*

Diagram 8

Attach trim strip to lift column

Notched end of trim strip  
Velcro strip  
Ribbon cable  
Lift column  
Trim strip

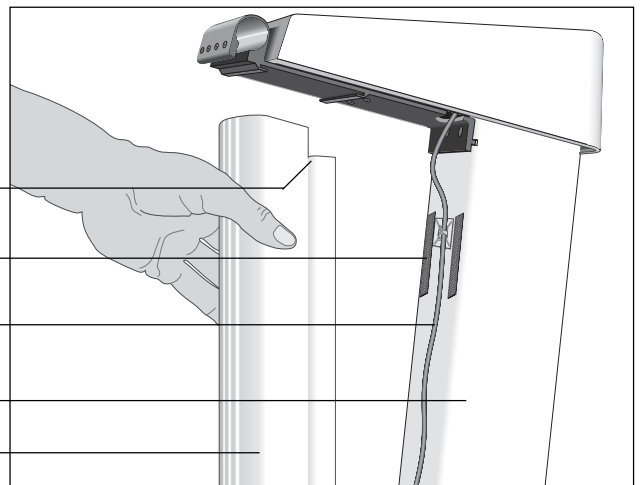

20. Attach the lift column trim by following these steps. While performing these steps, refer to Diagram 8 for further clarification.
- Position the trim strip so that the notched end points up. See Diagram 8.
  - Insert the base of the trim through the opening in the hood.
  - Raise the trim until the notched end of the trim touches the underside of the upper handrail clamp. Be careful to maintain vertical alignment of the trim with the lift column.
  - While maintaining alignment, attach the trim by pressing firmly against the lift column until the Velcro pads fasten securely to each other.

**CAUTION:** Make sure that the ribbon cable is situated in the trim strip's center slot before you take the next step. Cables crimped or pinched due to inaccurate assembly may not be covered by the limited warranty.

**Diagram 9**

*Install upper handrails*

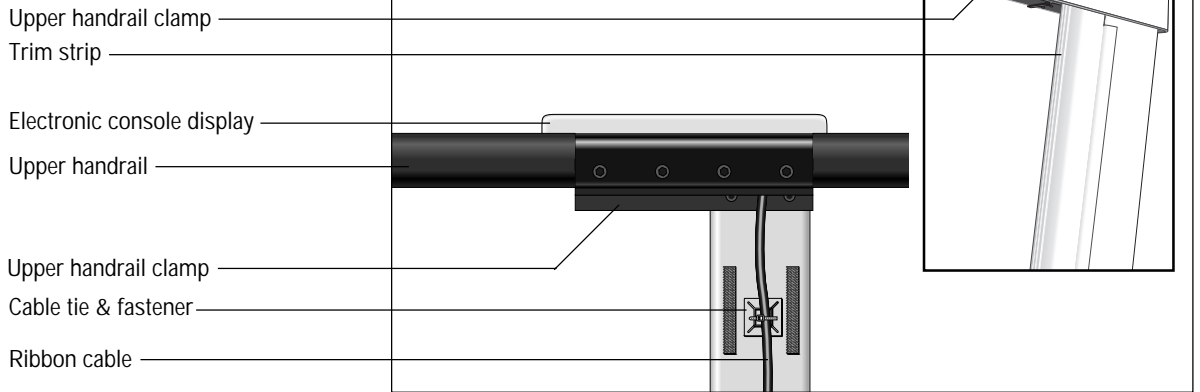

21. Insert the upper end of a handrail into the upper handrail clamp until the black foam wrap just touches the clamp. See Diagram 9. Set the base of the handrail on the floor. Repeat this step for the other handrail.

**Note:** Look underneath the upper handrail clamp to be sure that the handrail ends meet in the middle of the clamp.

22. Insert the four upper handrail clamp screws (C) into the upper handrail clamp and finger-tighten. *Do not tighten the screws more than finger tight at this point.*

**Diagram 10**

*Attach lower handrails*



23. To mount the lower portion of the handrails to the treadmill, refer to Diagram 10 while taking the following steps:

**Note:** Perform these steps on one side of the treadmill before proceeding to the other side.

- a. Use the supplied hex key (G) to remove the screws that hold the lower handrail clamp in place.
- b. Place the lower portion of the handrail onto the plastic cradle. You may need to gently flex the lower portion of the handrail toward the front of the treadmill to securely seat the end of the tube onto the projecting ledge of the cradle.
- c. Re-install the handrail clamp over the tube, align the screw holes, insert and finger-tighten each screw.
- d. To secure the handrail inside the clamp, use the hex key (G) provided. Do not overtighten the screw or damage may occur to the clamp.

**Note:** After extensive use, vibrations from the treadmill may cause the clamp to loosen. You may need to periodically inspect the screws and, if necessary, tighten the handrail clamp screws using the hex key (G) provided.

- e. Proceed to the other side of the treadmill and follow steps a through d to complete the installation of the lower handrails.
24. Return to the upper handrail clamp, look underneath the clamp to be sure that the handrail ends meet in the middle of the clamp, readjust the handrails if necessary, and *tighten the screws securely using the hex key (F) provided.*
25. If you need to move the treadmill, ask for additional assistance. Check to be sure the treadmill is turned OFF and the power cord is unplugged from the power outlet. Roll the treadmill on its front wheels to the new location by lifting the rear end of the unit.
26. Plug the treadmill into a standard 120v household outlet. Make sure that no other appliances use the same circuit as the treadmill.
27. Continue on to *Checking the Alignment of the Running Belt* on the following page to complete the installation of the treadmill.

**CAUTION:** Do not remove the 3-prong plug or otherwise bypass it with an adapter in order to use a non-grounded outlet.

### Checking the Alignment of the Running Belt

The belt is aligned at the factory before shipment. However, during shipment or by using the treadmill on an uneven surface, the belt might move off center. Proper belt alignment is important because it allows the belt to remain centered and assures smooth operation. Follow these steps to check the alignment:

**CAUTION:** Do not walk on the running belt during this procedure.

1. On the electronic console, move the magnetic safety key to the ACTIVATE position. Locate the ON/OFF switch at the front of the treadmill and turn ON the treadmill.
2. Stand beside the treadmill and answer the standard start-up questions as instructed below:
  - a. At the "ENTER WEIGHT" prompt, specify a weight and press the SCAN/ENTER key.
  - b. At the "SELECT COURSE" prompt, use the arrow keys to select "MANL" (Manual) mode and press SCAN/ENTER.
3. Continue standing next to the treadmill and bring the running belt up to a speed of 2 miles per hour by pressing the SPEED ▲ key.
4. Walk to the back of the treadmill and observe the belt as it moves (watch for a couple of minutes).

**CAUTION:** If you hear or notice any chafing or the running belt appears to be getting damaged, stop the running belt immediately by pressing the STOP key. Contact a Precor Service Representative.

If the running belt, ...	Then, ...
tracks within the green portion of the label	the belt is functioning correctly and no adjustment is necessary.
runs or drifts into the red portion of the label	you need to adjust the belt; see <i>Aligning the Running Belt</i> in Chapter 6.

**Important:** If you notice that the belt needs alignment, make the adjustments at once. Failure to do so might cause the belt to tear or fray which is not covered by the **Precor limited warranty.**

5. Press STOP or SPEED ▼ until the running belt stops.  
If the belt is functioning correctly, the treadmill is ready to use.

# 3

## Using the M9.1 or M9.2s Treadmill

As simple as using the M9.1 or M9.2s treadmill might seem, you should read this section so that you can use it safely and effectively. This section provides information about the electronic console features which include the following:

- information about the ON/OFF (I/O) switch
- instructions for using the magnetic safety key
- a brief description of the electronic console
- instructions for changing the display from U.S. Standard to Metric
- **M9.2s only** — instructions for selecting the Time or Distance prompt

### Locating the ON and OFF Switch

Use the ON/OFF (I/O) power switch to turn the treadmill ON or OFF. This switch is located at the front of the treadmill, near the power cord.

**Note:** You cannot turn ON (I) the treadmill until the magnetic safety key is placed in the ACTIVATE position.

### Using the Magnetic Safety Key

The magnetic safety key lets you stop the treadmill's running belt. Use this key in an emergency or when you are finished exercising. Pulling the key off the console or moving it to the OFF position, has the same effect as turning OFF the treadmill using the ON/OFF switch. Once you remove the key from the ACTIVATE position, the running belt slows to a gradual stop.

**Important:** Always attach the magnetic safety key to your clothing before each workout. Use the clip provided on the end of the cord.

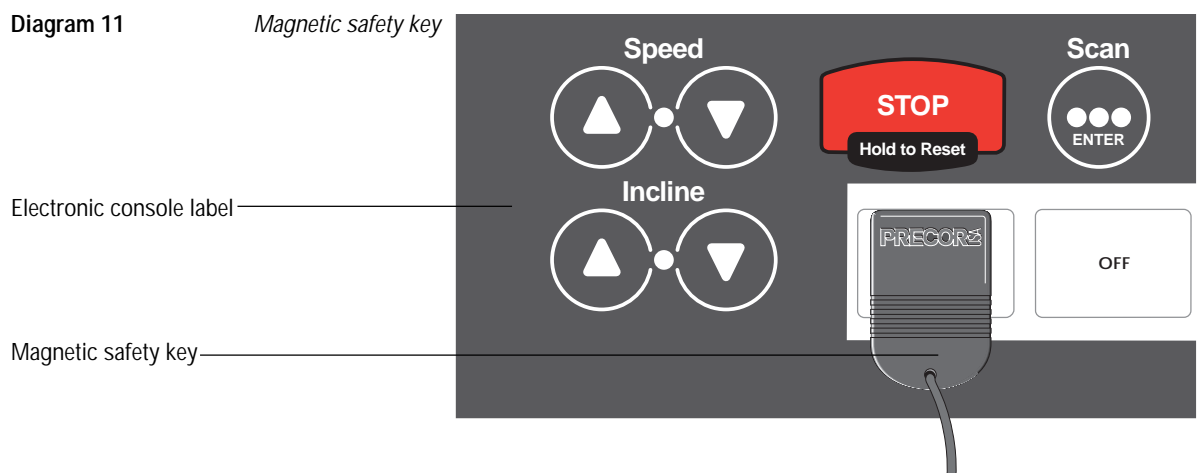

Before you can operate the treadmill, you must move the magnetic safety key to the ACTIVATE position on the electronic console. See Diagram 11. The treadmill will not turn ON unless the safety key is in this position.



## Understanding the Electronic Console

The electronic console lets you control your workout session. As you work out, the electronic display provides constant feedback about your progress. Information about distance covered, elapsed time, speed, calories burned, and degree of incline is available at any time. Diagram 12 shows an example of the M9.2s electronic console display.

## Displays on the Electronic Console

The indicator lights on the electronic console show you what information is being displayed. Information from five distinct fields (shown in Diagram 12) can appear: DISTANCE, TIME, SPEED, CALORIES, and INCLINE.

Diagram 12

*M9.2s electronic console display*



**DISTANCE:** The distance you have travelled appears once you begin a workout. Distance can appear in miles or kilometers. If you bought your treadmill in the U.S., it is programmed at the factory to display the U.S. standard unit of measure. If you wish to change the display, you can follow the instructions found in *Changing the Display to U.S. Standard or Metric*. The maximum distance you can travel in a single workout is 99.99 miles (161 km) before the odometer resets at 00.00 and begins over again.

**TIME:** During your workout, a time (00:00) display appears automatically and stops whenever you stop walking or running. As you work out, you will notice that the time starts at zero and counts up when you use manual or interval modes.

**SPEED:** Once you begin a workout, the speed at which you are travelling appears in this display. Your speed can appear in miles per hour (.5 to 9 mph) or kilometers per hour (.8 to 14 kph). If you wish to change the display, see *Changing the Display to U.S. Standard or Metric*.

**CALORIES:** When you enter your accurate weight, the number of calories you are burning appears in this display while you work out. At the end of your workout, the total calories burned is displayed.

**INCLINE:** The M9.1 and M9.2s treadmills provide a range of inclines from 1% to 10%. On the M9.1 you have to use the incline crank to adjust the incline. On the M9.2s, you press the INCLINE ▲▼ keys to increase or decrease the incline level of your workout.

## Keys on the Electronic Console

The keys on the electronic console let you change the speed, stop the treadmill, reset the displays, or control which features appear on the display. Each key and its function is explained below:

**SPEED ▲▼:** Use the SPEED ▲▼ keys to change belt speed. Belt speed starts at .5 miles per hour (mph) and increases in .1 mph (.2 kph) increments while you hold the ▲ key. You can increase speed up to 9 mph (14 kph). When you decrease speed, belt speed decreases at a rate of .1 mph (.2 kph) while you hold the ▼ key. You can stop the running belt in this way.

Anytime during your workout, you can view your speed in minutes per mile (or kilometer). In other words, you can see how many minutes it takes you to walk or jog a mile (or kilometer). To use this feature, simultaneously press both SPEED ▲▼ keys and the information will appear on the screen. When you release both keys, the speed display returns to the per hour measurement you originally set. See *Changing the Display to U.S. Standard or Metric*.

**STOP:** To pause or end your workout, press the STOP key. The running belt stops and the displays on the console freeze.

**SCAN/ENTER:** The SCAN/ENTER key has three functions which let you:

- alternate between the displays every few seconds (SCAN).
- accept specific prompt selections (ENTER).
- highlight specific displays (ENTER).

### SCAN

In general, the electronic console display is set to scan, so the different features (DISTANCE, TIME, SPEED, CALORIES, and INCLINE) alternately appear in sequence every few seconds. If the display is set to "scan," two indicator lights appear to the left of the word SCAN on the display and remain stationary while you are in the SCAN mode. Another two indicator lights appear next to the field that is being displayed. The indicator lights move sequentially through each field every time a new field appears on the display.

### ENTER

To cause a specific feature, such as the SPEED, to continuously appear on the display, press the ENTER key until the two round indicator lights appear next to the word "SPEED."

To specify a weight, select a workout mode (INTV or MANL), or reset U.S. Standard or Metric configurations, you need to use the ENTER key.

If you wish to display a particular feature during your workout, press the ENTER key until the pair of lights appear next to the feature you want to display. The pair of lights next to a particular feature, such as TIME, indicate which feature is currently being displayed.

**ACTIVATE:** If the magnetic safety key is not in the ACTIVATE position, you cannot turn ON the treadmill. If used properly, the magnetic safety key helps to protect you from injury during your workout. Attach the magnetic safety key to your clothing prior to stepping onto the running bed and beginning your workout. If you encounter a problem during your workout, simply pull on the safety key's cord to stop the running belt. When the magnetic safety key is removed from the ACTIVATE position, it trips the treadmill's circuit breaker, turns OFF the treadmill, and stops the running belt.

**OFF:** After completing your workout by pressing the STOP key, place the magnetic safety key on the OFF position. This turns OFF the treadmill. Remove the magnetic safety key and store it in a safe place to ensure that children or an unauthorized person will not be able to activate or use the treadmill.

## Changing the Display to U.S. Standard or Metric

The M9.1 or M9.2s treadmill can display speed in either miles per hour (mph) or kilometers per hour (kph). When the treadmill is shipped from the factory, it is set to display in U.S. Standard units of measure. You can easily change these settings by taking the following steps:

**Note:** The treadmill will retain your selection even when it is turned OFF and unplugged. You can change your selection at any time, simply by repeating the following steps.

1. Place the magnetic safety key in the ACTIVATE position on the electronic console. Walk to the front of the treadmill and turn the power switch ON. (The magnetic safety key must be placed in the ACTIVATE position before you can turn ON the treadmill.)
2. Straddle the running belt with your feet firmly planted on the right and left side platforms. (Stand close enough to the electronic console, so that you can extend your arm and touch the keypad.) Use the clip on the magnetic safety key and attach it to your clothing at your waistline.
3. At the "ENTER WEIGHT" prompt, simultaneously press and hold the SPEED ▲ key and the SCAN key. The prompt, "PRESS ▲ FOR MPH & MILES MODE OR ▼ FOR KPH & KILOMETERS MODE" appears on the display. Release both keys.
4. Use the appropriate SPEED ▲ or ▼ key to indicate your selection.

You can continue your workout by following the appropriate steps found in Quick Steps to Working Out or turn OFF the treadmill by moving the magnetic safety key to the OFF position.

## Selecting the Time or Distance Prompt on the M9.2s

When using a M9.2s preprogrammed course, you can measure your workout by distance or time. You see the "SELECT DISTANCE" or "SELECT TIME" prompt after you enter a course selection. The default measurement is distance.

To change the prompt, follow the steps above in *Changing the Display to U.S. Standard or Metric*.

1. After step 4 above, two messages scroll across the display: one confirms your mph or kph selection and the other states, "PUSH ▲ FOR DISTANCE ▼ FOR TIME OR 'STOP' FOR ASK." Press the appropriate key after answering one of the following if/then scenarios:

If you want,...	Then,...
your workout measured by distance	press the ▲ key
your workout measured by time	press the ▼ key
the option of selecting time or distance prior to each workout	press STOP

After you press an arrow key, a message scrolls across the display confirming your selection.

2. Continue with your workout or turn OFF the treadmill by removing the magnetic safety key from the ACTIVATE position on the electronic console. If you turn OFF the treadmill, be sure to store the safety key in a safe place to prevent unauthorized use.

# 4

## Working Out on Your Treadmill

A variety of exercise options are available on the M9.1 and M9.2s treadmills which are discussed in this section and include:

- instructions for exercising on the treadmill
- an explanation of how to change incline on the M9.1
- information about how to retrieve a previous workout
- instructions for pausing or ending your workout
- information about how to incorporate a cool-down period
- information about using Manual, Interval, and Program modes

Before using your treadmill, we recommend that you read these instructions and go through a preliminary demonstration of the treadmill. Then, you will be familiar with the treadmill when you begin your workout.

***CAUTION: If this is the first time you have operated this treadmill, DO NOT STAND on the running belt until you become familiar its operation.***

When using the treadmill, follow these general guidelines:

- At the beginning of a workout, take several minutes to bring your heart rate into your training zone, which is shown in Diagram 14 later in this manual.
- After your workout, walk slowly for several minutes to cool down your body and lower your heart rate.
- Using the clip provided, attach the magnetic safety key to your clothing before each workout. Then, if you encounter difficulties or want to end your workout, you can easily stop the running belt by pulling on the cord.
- Gently stretch your lower body and back before and after a workout to help prevent stiffness or soreness.

---

**Photo 1**

*Working out on  
the treadmill*

## Quick Steps to Working Out

1 Position the Safety Key on **ACTIVATE**. Turn ON treadmill.

2 Straddle belt.

3 Attach safety clip to clothing.

4 Enter Weight

**Tip**—If you want to access the last course stored in memory, at the “ENTER WEIGHT” prompt, tap the ENTER key 3 times.

5 Select Course.

6 Start working out.

**Tip**—Use the optional Smart Weights to enjoy the added benefit of an upper body workout. **(Pause)**  
To purchase Smart Weights, call your local dealer 1-800-4-PRECOR.

7 End workout.

**(Cool down)**

8 Review workout statistics.  
**(Press HOLD TO RESET)**

9 Remove Safety Key and store it in a secure place. Turn OFF the treadmill.

To workout on the treadmill, follow these instructions.

1. On the electronic console, place the magnetic safety key in the **ACTIVATE** position. Walk to the front of the treadmill and turn ON the treadmill using the ON/OFF switch. The safety key must be in the **ACTIVATE** position before you can turn ON the treadmill.
2. Straddle the running belt with your feet firmly planted on the right and left side platforms. Stand close enough to the electronic console so you can extend your arms and touch the keypad.
3. Using the clip provided, securely attach the magnetic safety key to your clothing at your waistline where it will not interfere with your workout.
4. When you see “**ENTER WEIGHT**” scroll across the display, specify your weight using the ▲▼ keys. When the correct weight is displayed, press ENTER.

The number on the display moves in 5-pound (2-kilogram) increments. You must select the weight closest to your actual weight so that the treadmill can provide accurate feedback about calories burned during a workout.

Once your weight is specified, you may not need to enter it again. The treadmill automatically remembers the last weight entered. At your next workout, simply press ENTER at the “**ENTER WEIGHT**” prompt. (If another person has used the machine and changed the weight, you will need to re-enter your weight as described in this step.)

5. At the “**SELECT COURSE**” prompt, choose your workout mode, either Interval (INTV), Manual (MANL), or one of the preprogrammed courses (**M9.2s only**). Press the ▲▼ keys until you see the desired mode, then press ENTER. For more information about the two different modes, read the following pages.

Once you specify the mode, the treadmill automatically remembers it. If no one else uses the treadmill or makes any changes before your next workout, you can simply press ENTER at the “**SELECT COURSE**” prompt and activate the same mode.

**Important:** If you choose “INTV” mode, refer to *Changing the Interval Course Profile* before continuing on to the next steps.

6. Hold onto the handrail with one hand and press the SPEED ▲ key with the other hand. Step onto the running belt while it is at or below 1 mph. Once you are comfortable with the walking or running speed, you may remove your hands from the handrail.

**Note:** To pause during your workout session, press the STOP key. The features on the display remain, but your workout statistics stop accumulating. See *Pausing Your Workout* or *Ending Your Workout* for more information. Remember to hold onto the handrail when using the electronic console and when slowing down or stopping the running belt.

7. When you are finished exercising, hold onto the handrail and press STOP or press SPEED ▼. The running belt slows to a stop. You can then review your workout results as the display scans through DISTANCE, TIME, and CALORIES.

**Important:** Always allow yourself a cool-down period of a few minutes before bringing the running belt to a complete stop. On the M9.2s, press STOP twice in quick succession at the end of a course to access Manual mode and begin a cool-down period.

8. If desired, after reviewing the displays, reset them to zero by pressing and holding STOP for several seconds.
9. Detach the magnetic safety key cord from your clothing and place the safety key in the OFF position on the electronic console. The treadmill turns OFF. To prevent unauthorized use, remove the safety key from the treadmill and store it in a safe place.

## Changing Incline on the M9.1

When you use the incline crank handle, you can change the incline, up to 10 %.

- to **raise** the incline, rotate the handle *clockwise*
- to **lower** the incline, rotate the handle *counterclockwise*

Incline changes occur in 1% increments. Whenever you change the incline, the percent of incline automatically appears on the console display.

You can change incline anytime during your workout. However, you should stand on the sides of the treadmill (the side platforms) and straddle the running belt when you change the incline.

## Retrieving the Previous Workout Program

To retrieve the previous workout program, simply tap the ENTER key successively three times while the start-up prompt “ENTER WEIGHT” is being displayed. Note that if someone else has exercised on the treadmill after your workout, whatever program he or she used will be the one that is restored from memory.

## Pausing Your Workout

You can pause at any time during your workout. Use this feature to rest or take a short break. To pause while working out, press the STOP key. The running belt stops. Remove the safety key clip and straddle the running belt so that you can safely step off the treadmill. Your workout statistics freeze and remain displayed on the console until you resume your workout.

Do not rely on the Pause feature as a way to end your workout. If you wish to end your workout, follow the instructions in *Ending Your Workout*.

To resume your workout, straddle the running belt, attach the safety key clip to your clothing, press the SPEED ▲ key to start the running belt, hold the handrail, and step onto the running belt while the speed is at or below 1 mph. Your workout statistics continue from where you left off. Continue to press the SPEED ▲ key, to increase the speed to a comfortable level. Once you are comfortable with the walking or running speed, you can remove your hands from the handrail.

## Cooling Down After a Workout

Cooling down after your workout is important because it helps reduce muscle stiffness and soreness by transporting excess lactic acid out of the working muscles. It also provides a smooth transition that allows your heart rate to return to its normal (non-exercising) state.

You can cool down after a workout by accessing manual mode (MANL). Manual mode lets you change the speed and incline and adapt a cool-down period to your particular workout. Tapping STOP twice in quick succession accesses MANL mode from any of the treadmill's programs.

## Ending Your Workout

To end your workout, take the following steps:

1. Hold onto the handrail and press the STOP key or press the SPEED ▼ key until the running belt slows to a gradual stop. The displays on the console freeze which lets you review your workout statistics.
2. Continue to press STOP (HOLD TO RESET) for a few more seconds to add your workout statistics to the cumulative totals and return to the “ENTER WEIGHT” prompt.
3. Straddle the running belt and step off the treadmill.
4. To prevent unauthorized use, remove the magnetic safety key and store it in a safe place. To access the same program the next time you workout, tap the ENTER key successively three times.

## Using the Manual Course Mode

Manual mode lets you use the treadmill for an indefinite period of time while controlling the speed and incline of your workout. All of your workout statistics are compiled and displayed on the electronic console.

To use Manual mode, follow the steps in *Working Out on Your Precor Treadmill*. At the “**SELECT COURSE**” prompt, choose “**MANL.**”

On the M9.2s, if the “**SELECT MILES**” or “**SELECT TIME**” prompt scrolls across the display, specify the length of your course or the length of your workout using the ▲▼ keys, and then, press ENTER.

**Note:** On the M9.2s, you can choose a distance from .5 to 99.5 miles (kilometers) or a length of time from 5 to 99 minutes. You can select which prompt appears by following the instructions in *Selecting the Time or Distance Prompt*.

## Changing the Interval Course Profile

Interval training provides numerous benefits. Since interval training segments the workout into smaller components, a 20- or 30-minute workout seems to pass more quickly. In addition, studies have shown that it is a more efficient method for achieving aerobic benefits—you start seeing improved cardiovascular fitness much sooner with less effort. Studies also show that people who interval train are more likely to stick with their fitness program.

The interval course on the M9.1 or M9.2s treadmill lets you set course intervals according to your training regimen. It alternates between 60 seconds of “Rest” and 60 seconds of “Work.” During the Rest interval, you can walk or jog slowly; during the Work interval, you can stride quickly or run. You set the speed for the first rest and work interval and the software takes over from there, repeating the intervals throughout the course until you press the STOP key.

At any point during the workout, you can change the speed of the current interval. For example, if 8 mph is a little faster than you prefer during a Work interval, simply use the SPEED ▼ key to reduce speed. The software remembers the new speed for the next Work interval.

To help you monitor your workout, you can set the treadmill’s electronic display to SCAN by pressing the SCAN key until the indicator lights appear next to the word SCAN on the display. This mode displays a sequential readout on DISTANCE, TIME, SPEED, CALORIES, and INCLINE.

**Note:** If you pause your workout during an Interval mode, you must reset the speed of the mode you were in when you paused your workout. For example, if you paused your workout during the Rest interval, you must reset the speed for that interval. In this example, you would not need to reset the speed for the Work interval since it is still stored in memory.

Below are some suggestions that may help you incorporate the Interval mode into your workout:

- If you are starting an exercise program, the Interval mode option can help you increase your workload gradually. For example, in the beginning, you may simply want to specify the same speed and incline for both Work and Rest intervals. Then, to increase your effort level, change to a higher speed and/or incline for your Work interval.
- If you are training with the goal of maintaining a constant pace when on level ground or grade, specify the same speed for both Work and Rest intervals. Then, gradually increase the incline during the Work interval until you can maintain a constant pace.

To use the interval course, follow the steps in *Quick Steps to Working Out*. “**SELECT COURSE**” prompt, use the ▲▼ keys to display “**INTV,**” and press ENTER.

To set the interval for the course, take the following steps:

1. When you see the scrolling prompt requesting that you enter your **rest** speed (*and incline — M9.2s only*), stand on the running belt with one hand on the handrail, prepared to start walking. With your other hand, press the SPEED ▲ key until you reach a comfortable rest speed, either running or walking. When the desired speed is displayed, simply continue working out—you do not need to press ENTER.

Once you reach your desired rest speed, the treadmill remembers that speed and returns to it at the beginning of each rest interval, until you change the speed or end your workout.

2. The next scrolling prompt requests that you specify your **work** speed (*and work incline — M9.2s only*). With one hand on the handrail, use the other hand to press the SPEED ▲▼ keys until the desired work speed (up to 9 mph) is shown. When you are comfortable with the rest and work speeds, you can let go of the handrail.

**Note:** On the M9.1, use the incline crank handle to change the degree of incline. Hold onto the handrail with one hand while you rotate the crank in a *clockwise* direction to raise the incline with the other hand. To lower the incline, rotate the handle *counterclockwise*.

Each rest and work interval lasts 60 seconds. The display automatically counts down to the next interval. When the count reaches 30 seconds, the display changes and gives information about distance travelled, time elapsed, speed, calories burned, and percent of incline.

When the treadmill changes intervals, it informs you by scrolling a message across the display.

Using the interval course mode, you can cool down before ending your workout by pressing STOP twice in quick succession. The treadmill enters manual mode, letting you specify the speed of your cool-down period.

## Using the M9.2s Preprogrammed Courses

**CAUTION:** *If this is the first time you have operated this treadmill, DO NOT STAND on the running belt until you become familiar the M9.2s operation. Be sure to read and follow the general guidelines found in “Working Out on Your Precor Treadmill.”*

To use a preprogrammed course, follow the instructions below. Remember, when you use the electronic console, hold onto the handrail to maintain your balance. You should also use the handrail whenever you speed up, slow down, or stop the treadmill.

1. On the electronic console, move the magnetic safety key to the ACTIVATE position as shown in Diagram 11, page 10. Walk to the front of the treadmill and turn ON the treadmill using the ON/OFF switch. The treadmill switch will not turn ON unless the safety key is seated securely in the ACTIVATE position.
2. Straddle the running belt with your feet firmly planted on the right and left side platforms. Stand close enough to the electronic console so that you can extend your arms and activate the keys.
3. Using the clip provided, securely attach the magnetic safety key to your clothing at your waistline, where it will not interfere with your workout.
4. When you see “ENTER WEIGHT” scroll across the display, specify your weight using any ▲▼ key. When the correct weight is displayed, press ENTER. This information allows the M9.2s to calculate how many calories you use during your workout.

The number on the display moves in 5-pound increments up or down, depending on the arrow key pressed. Use ▲ to increase and ▼ to decrease the weight displayed.

**CAUTION:** *Before beginning any fitness program, you should have a complete physical examination by your physician. If you are unsure about your level of fitness, consult your physician. Always start your workout at the low or “WALK 1” level and work to increase your level of fitness before performing moderate or advanced workout routines.*

Once your weight is specified, you may not need to enter it again. The treadmill automatically remembers the last weight entered (unless the treadmill is turned OFF). At your next workout, you restore your weight from the treadmill’s memory by simply pressing ENTER at the “ENTER WEIGHT” prompt. However, if someone else has used the treadmill and made changes prior to your workout, you will need to re-enter your weight.

**Note:** The prompt “PRESS ENTER TO BEGIN” appears after a few seconds if you have not chosen a course and pressed ENTER. This prompt continues to scroll across the display every few seconds until you press ENTER.



5. At the **"SELECT COURSE"** prompt, choose your workout course using the ▲▼ keys: either WALK 1 through WALK 5 or RUN 1 through RUN 5 and then press ENTER. The course you choose takes you through a set series of incline intervals with inclines varying according to the level of the course.

The label on the electronic console shows the available courses. The courses combine .5-mile segments with a set series of inclines. The percent of incline and the frequency with which inclines are encountered indicate the difficulty of the course. For example, WALK 1 takes the user through inclines ranging from 0 to 3 percent grade, while RUN 5 uses inclines in the minimum to maximum range on a more frequent basis. The program repeats the .5-mile segments until the distance or time limit you set is reached, or you press the STOP key.

**Note:** If you do not press ENTER to select a course, after 10 seconds the prompt **"PRESS ENTER TO BEGIN"** appears. This prompt continues to scroll across the display every few seconds until ENTER is pressed.

6. At the **"SELECT MILES (kilometers)"** prompt, specify the length of your course. Press the arrow keys to choose distance; the display moves in .5 increments, from .5 to 99.5 miles (.8 to 160 kilometers). Press ENTER when the desired distance appears.

**Note:** You can change the **"SELECT TIME"** prompt to **"SELECT DISTANCE"** if you prefer to measure your workout by distance. Follow the procedure in *Selecting the Time or Distance Prompt*.

If you see **"SELECT TIME"** scroll across the display, specify the length of your workout. Press the ▲ or ▼ key to choose time; the display moves in 1-minute increments, from 5 to 99 minutes. Press ENTER when the desired time appears.

7. Stand on the running belt with one hand on the handrail, prepared to start walking. With your other hand, press the SPEED ▲ until you reach your desired speed.

The course will continue until the specified distance or time is reached, or until the STOP key is pressed. Any time during your workout, you can change your speed. However, since the incline is preset, the incline keys are disabled.

8. When you are finished working out or you have come to the end of the course, hold onto the handrail and press STOP. The treadmill will come to a safe stop. Be sure to remove the safety clip from your clothing and return it to the OFF position on the electronic console. To prevent unauthorized use, remove the safety key and store it in a safe place.

**Note:** If desired, you can cool down before ending your workout by pressing STOP twice in quick succession. The treadmill will stop and enter the Manual mode, allowing you to specify the speed and incline of your cool-down period.

# 5

## Getting the Most Out of Your Workout

A workout on the M9.1 or M9.2s Precision Electronic Treadmill provides excellent and efficient cardiovascular conditioning, while strengthening and toning all the major muscle groups in the lower body. Darkened areas in Diagram 13 indicate the muscles improved.

**Diagram 13**

*Muscles improved*

1. Trapezius
2. Deltoid
3. Pectorals
4. Rhomboids
5. Triceps
6. Biceps
7. Latissimus Dorsi
8. Forearm Flexors/Extensors
9. Abdominals
- 10. Erector Spinae**
- 11. Gluteals**
- 12. Hip Flexors**
- 13. Quadriceps**
- 14. Hamstrings**
- 15. Gastrocnemius/Soleus**
- 16. Peroneus Longus/Brevis**

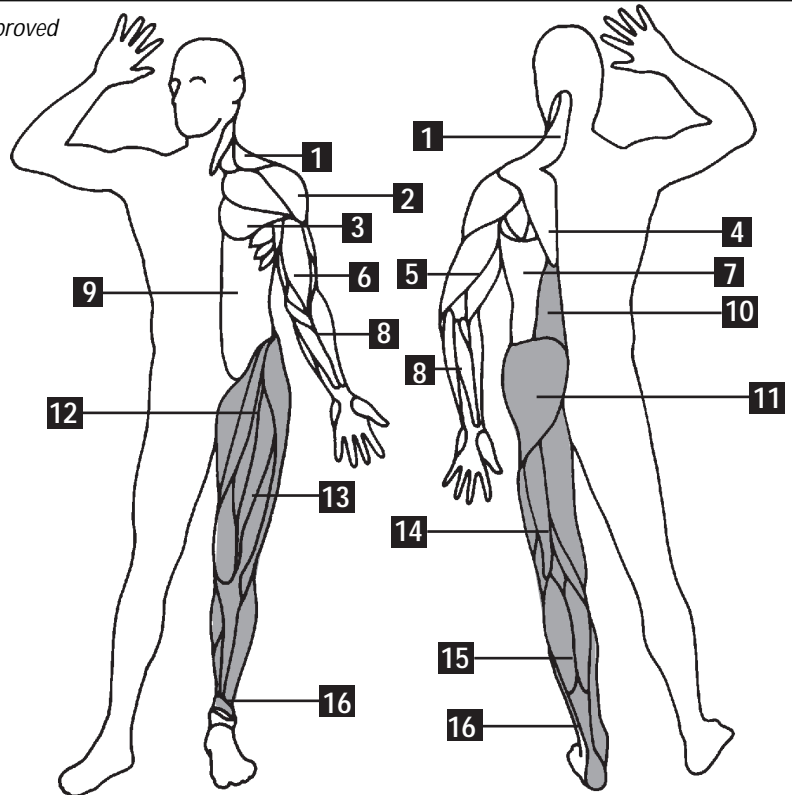

To get the most out of each workout, a general understanding of the principles behind aerobic training is invaluable. The best source of information is your specialty fitness dealer. In addition to providing information on which exercise equipment is best for your individual needs, your fitness dealer can provide useful advice on training, technique, and exercise physiology. Your dealer can also recommend good books and videos on these subjects.

To help you get started in planning and carrying out your fitness program, this section provides some basic information on aerobic exercise—such as how hard should you work out, how long each session should be, and how often you need to exercise to benefit from a regular program.

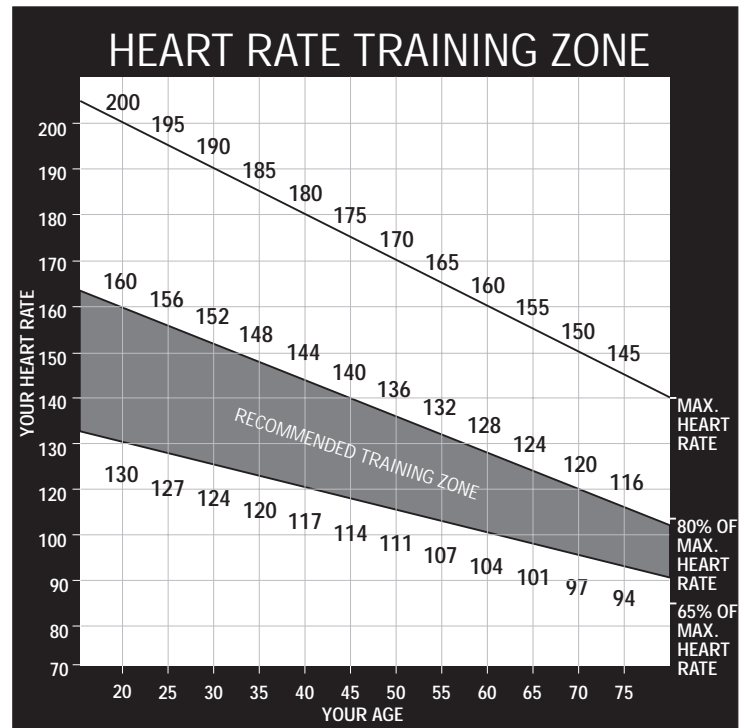

## How Hard Should I Exercise?

Studies show that to achieve the benefits of aerobic exercise, it is necessary to work out hard enough to raise your heart rate to a certain minimum level, called the "training zone." Your training zone depends on your age and level of fitness.

Diagram 14 shows your recommended heart rate training zone, which is calculated using your age and your maximum aerobic heart rate. The chart is based on a resting heart rate of about 72 for males and 80 for females. Your optimum training zone is between 65% and 80% of your maximum aerobic heart rate. For efficient aerobic exercise, work only hard enough to keep your heart rate in this zone. You will obtain the greatest fat-burning benefits when you exercise within the optimum training zone.

Pushing yourself beyond the recommended range, (that is, exercising so hard that your heart rate rises above 80% of maximum) can overstress your muscles. To increase cardiovascular improvement, exercise *longer*, not harder.

Keep in mind that this zone is an approximation, to be used as a guideline—individual heart rates vary according to several physiological factors. To determine your training zone, find your age on the diagram, and then find the line where they intersect. For example, if you are 35 years old, your training zone is between 120 and 148 beats per minute. Remember this zone—this is the heart rate zone you should try to maintain as you work out.

If you do not have an accurate heart rate monitor, you can determine your heart rate by taking your pulse at a place that you can reach easily and comfortably while you exercise. Typical places for measuring heart rate are directly over the heart on the left side of the chest, on either side of the neck, over the temple, or on the thumb side of either wrist. Wherever you measure your pulse, make sure that you use your index and middle fingers—**not your thumb**. Your thumb has a strong pulse and can affect your pulse rate reading.

Once you locate your pulse, look at a clock with a second hand, and count the beats for six seconds. Multiply that number by 10 to determine the total number of beats per minute. For example, if you count 14 beats over six seconds, the total number of beats per minute is 140. Compare the total number of beats with your training zone as identified in Diagram 14. If necessary, increase or decrease your activity level to bring your heart rate into your training zone. You can regulate your work level (and heart rate) by changing belt speed and incline. **Remember—your heart rate is the definitive measure of how hard you are working.**

Regardless of your fitness level, avoid doing too much too soon. Running or walking too fast or choosing too high of an incline are common errors. Give yourself time to become familiar with your treadmill and to improve your fitness level. Then you can gradually increase speed and incline to make your workouts more challenging.

## How Long Should I Exercise?

The length of each exercise session depends on your fitness level. Exercise physiologists have determined that, to attain cardiovascular benefits from exercise, you should maintain your heart rate in its training zone for at least 15 minutes. This is in addition to your warm-up time, and does not include cool down. You should always allow several minutes to bring your heart rate into the training zone, by starting out slowly and gradually increasing work level. Similarly, use several minutes of light exercise after the workout to bring your heart rate down to near resting level.

The higher your fitness level, the longer you should maintain your heart rate in the training zone (between 20 and 30 minutes). Beginners should always start slowly, and gradually bring their sessions up to 20 minutes or more.

## How Often Should I Exercise?

Research indicates that aerobic sessions of 20 minutes or more should be done at least three to five times a week to obtain significant cardiovascular benefits. Most experts agree that sensible eating habits and regular aerobic exercise are the keys to weight control and fitness. A recent study, which tracked several subjects over a period of years, conclusively shows that exercise, not dieting, is the key factor to long-term weight loss.

# 6

## Maintaining Your Treadmill

The M9.1 or M9.2s Precision Electronic Treadmill requires little maintenance to keep it running smoothly and efficiently. However, the customer is responsible for the typical maintenance tasks such as, cleaning the treadmill and adjusting the running belt. If you fail to maintain the treadmill as described below, it could affect or void the Precor limited warranty.

**CAUTION:** Turn OFF the treadmill and disconnect the power cable before performing most maintenance tasks.

### Cleaning the Equipment

Your Precor treadmill relies on low friction for efficient operation. To keep the friction low, the treadmill must be as clean as possible.

Before a workout, use a damp, soft, clean cloth to clean the side platforms and running bed, (refer to the callouts in Diagram 15 on page 24). This removes any dirt or dust that might affect the smooth operation of the treadmill.

Vacuum the floor underneath the unit every week to prevent the accumulation of dust and dirt on the running belt.

To periodically clean the treadmill's frame, electronic console, and running belt use a solution of mild soap and water and dampen a clean cloth. To clean the running belt and the grooves on the plastic trim strip, use a soft nylon scrub brush. Never pour water or spray liquids on the electronic console. Allow the treadmill to dry completely before using it.

Manually advance the running belt to clean the opposite side. Do not clean the belt while the running belt is moving. Liquid can splash onto the motor causing damage to the equipment and possibly injuring you.

**CAUTION:** Special care must be taken when aligning the running belt. Turn OFF the treadmill while adjusting or working near the rear roller. Remove any loose clothing and tie back your hair. Be very careful to keep your fingers or any other object clear of the belt and rollers, especially in front of the roller and behind the deck. The treadmill will not stop immediately if an object becomes caught in the belt or rollers.

### Aligning the Running Belt

Before aligning the running belt, check its operation by following the procedure in *Checking the Alignment of the Running Belt* earlier in this manual. If you determine that the belt needs adjustment, follow the instructions here.

Realigning the belt takes a few simple adjustments. If you are unsure about this procedure, call your authorized Precor dealer for service (see *Obtaining Service* on page 25).

Follow the steps on the next page to adjust the running belt on the treadmill. To ensure your safety, make all adjustments while the treadmill is OFF.

1. Make sure the treadmill is OFF and the running belt has completely stopped.
2. Locate the left belt adjustment bolt at the rear of the treadmill. See Diagram 15 on the next page. The direction you turn the bolt depends on how the belt is tracking. Make all belt adjustments on the left rear corner bolt using the hex key (H) provided.
  - If the belt is off center to the LEFT, turn the adjusting bolt 1/4 turn clockwise, which moves the running belt to the right.
  - If the belt tracks off center to the RIGHT, turn the bolt 1/4 turn *counterclockwise*; this moves the belt to the left.

**Important:** Do not turn the adjusting bolt more than 1/4 turn at a time. *Overtightening the bolt can damage the treadmill.*

**CAUTION:** If you hear a chafing sound or the belt begins to tear or fray, stop the running belt immediately by pressing the STOP key or pulling the magnetic safety key off of the ACTIVATE position. Contact your Precor service representative.

3. Place the magnetic safety key in the ACTIVATE position and turn ON ( I ) the treadmill, answer the start-up prompts, then increase the running belt speed to 2 miles per hour by pressing the SPEED ▲ key.
4. Observe the running belt for a couple of minutes. The belt should track centered on the running bed.

**Diagram 15** *Aligning the running belt*

Side platform

Running bed

Rear roller

Belt adjustment bolt

Running belt

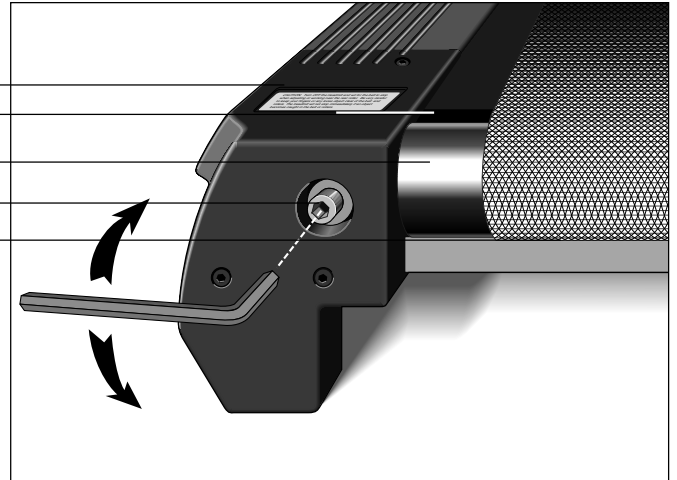

5. Press STOP or SPEED ▼ until the running belt comes to a complete stop.
6. If the belt needs additional alignment, repeat steps 1 through 5 of this procedure until the belt is properly aligned.

### Adjusting the Tension of the Belt

Proper belt tension is important for a smooth, steady run. If your physical condition permits, test the belt tension by jogging at 6 mph. If the belt tension is too loose, you will feel a pause in the belt with each footplant (step).

To adjust the running belt tension, take the following steps:

1. Make sure that the treadmill is OFF. If the treadmill is ON, switch it to OFF. Wait for the running belt to come to a complete stop.

**Diagram 16** *Adjusting the tension of the running belt*

Side platform

Running bed

Rear roller

Belt adjustment bolt

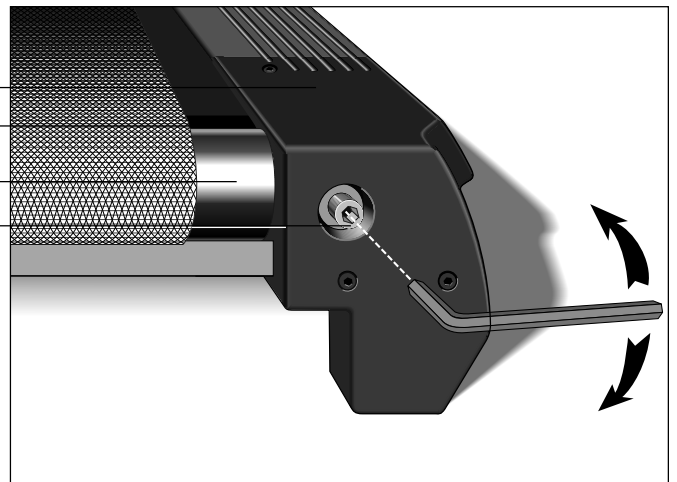

2. Standing behind the treadmill, use the rear belt adjustment bolts (each one at opposite sides of the rear roller). See Diagrams 15 and 16. Simply turn each bolt *clockwise* 1/4 turn to adjust the tension of the belt.
3. Turn ON the treadmill, answer the start-up prompts, then increase the speed of the running belt to 6 mph by pressing the SPEED ▲ key.
4. Jog on the running belt for 1 minute or more. If you feel a pause in the belt with each footplant (step), you need to continue to adjust the belt tension.

5. Press STOP or SPEED ▼ until the running belt comes to a complete stop.
6. Continue with steps 1 through 5 until the belt tension has been properly adjusted and you no longer feel the pause in the belt with each footplant.

**Important:** Do not turn the adjusting bolts more than 1/4 turn at a time. Overtightening the bolts can damage or cause premature failure of the precision bearings in the front and rear rollers.

## Servicing the Treadmill

Do not attempt to service the M9.1 or M9.2s yourself except for the maintenance tasks described in this manual. The M9.1 or M9.2s does not contain any user-serviceable parts, or parts that require lubrication. For information about product operation or service, contact an authorized Precor dealer at 1-800-4-PRECOR.

## Power Cord Maintenance

When the M9.1 or M9.2s is in use, ensure that the power supply cord is away from moving parts and cannot be damaged.

If the M9.1 or M9.2s power supply cord is damaged, it can only be replaced in a repair shop appointed by Precor because special tools are required.

## M9.1 or M9.2s Long Term Storage

When the M9.1 or M9.2s is not in use, ensure that the power supply cord is unplugged from the wall outlet and is positioned so that it will not become damaged or interfere with other equipment or people.

There are no special storage requirements for the M9.1 or M9.2s other than ensuring that it is kept free from dirt, moisture, or damage.

## Obtaining Service

Do not attempt to service the M9.1 or M9.2s Precision Electronic Treadmill yourself except for minor belt adjustments and maintenance as described in this manual. The treadmill does not contain any user-serviceable parts.

For information about product operation or service, contact an authorized Precor dealer or a Precor Factory Authorized Service Company. To locate the dealer or servicer nearest you, call 1-800-4-PRECOR.

To help the customer service representative expedite your call, have your serial number available.

The serial number on the treadmill is written on a label located underneath the treadmill at the left, rear corner of the running bed frame. If you haven't already written the serial number in the space provided below during the assembly process, you will need to get on your knees and bend down to see it.

Model number: M 9.1 Serial number: \_\_\_\_\_

Model number: M 9.2s Serial number: \_\_\_\_\_

If you have any questions regarding the treadmill, use the model and serial numbers whenever you call your Precor dealer or servicer.

# M9.1 and M9.2s Precision Electronic Treadmills

## Specifications

Length: 67.75 inches (172 cm)  
Width: 26.75 inches (68 cm)  
Height: 43.5 inches (110.5 cm)  
Motor: 1.5 hp continuous duty 90V DC  
Speed: 0.5 to 9 mph (0.8 to 14.48 kph)  
9 mph is equivalent to a 6.7 minute mile  
Incline: 0 to 10% grade  
Power: 50/60Hz, 120v AC single phase  
Weight: 192 lbs (87 kg)

## Electronic Specifications

### M9.1 Programs:

Manual  
Interval (1 minute rest: 1 minute work)

### M9.2s Programs:

Manual  
Interval (1 minute rest: 1 minute work)  
Programmed courses  
5 "Walk" courses  
5 "Run" courses

## Electronic Displays

Distance  
Time  
Speed  
Calories  
Incline  
Scan



Precor Incorporated  
P.O. Box 3004  
Bothell, WA USA 98041-3004

Precor and "M" are registered trademarks of Precor Incorporated.  
© 1996 Precor Incorporated.

P/N 37601-101  
8/96

Specifications subject to change without notice.  
1-800-4-PRECOR

### NOTICE:

Precor is widely recognized for its innovative, award winning designs of exercise equipment. Precor aggressively seeks U.S. and foreign patents for both the mechanical construction and the visual aspects of its product design. Any party contemplating the use of Precor's product designs is hereby forewarned that Precor considers the unauthorized appropriation of its proprietary rights to be a very serious matter. Precor will vigorously pursue all unauthorized appropriation of its proprietary rights.