

# **NordicTrack**<sup>®</sup> **VIEWPOINT 8500**

Model No. NTL22907.1

Serial No. \_\_\_\_\_

Write the serial number in the space above for reference.

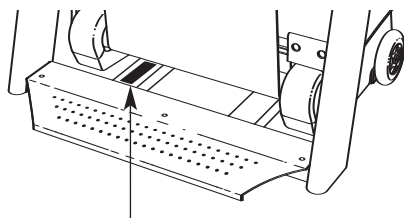

Serial Number Decal

## QUESTIONS?

As a manufacturer, we are committed to providing complete customer satisfaction. If you have questions, or if parts are damaged or missing, **PLEASE DO NOT CONTACT THE STORE; please contact Customer Care.**

**IMPORTANT:** You must note the product model number and serial number (see the drawing above) before contacting us:

CALL TOLL-FREE:

**1-888-825-2588**

Mon.–Fri. 6 a.m.–6 p.m. MST

Sat. 8 a.m.–4 p.m. MST

ON THE WEB:

[www.nordictrackservice.com](http://www.nordictrackservice.com)

## USER'S MANUAL

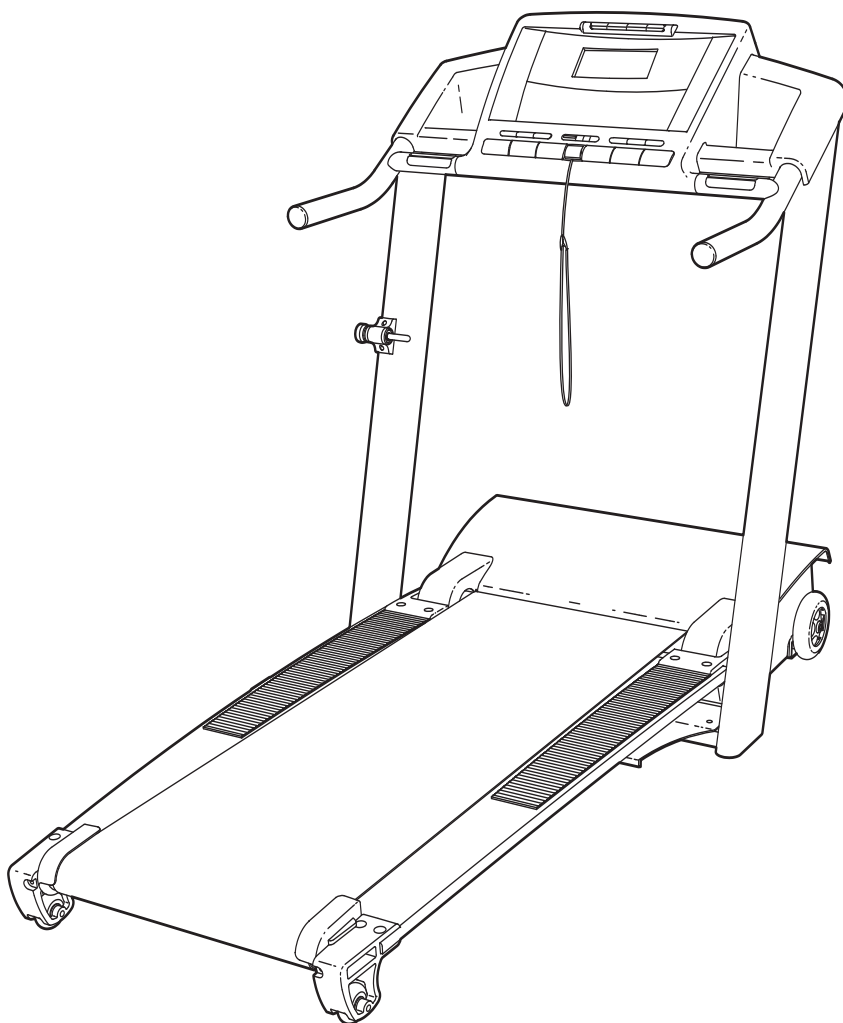

## CAUTION

Read all precautions and instructions in this manual before using this equipment. Save this manual for future reference.



Visit our website at

[www.nordictrack.com](http://www.nordictrack.com)

new products, prizes,  
fitness tips, and much more!

# TABLE OF CONTENTS

WARNING DECAL PLACEMENT .....2

IMPORTANT PRECAUTIONS .....3

BEFORE YOU BEGIN .....6

ASSEMBLY .....7

OPERATION AND ADJUSTMENT .....13

HOW TO FOLD AND MOVE THE TREADMILL .....26

TROUBLESHOOTING .....28

CONDITIONING GUIDELINES .....31

PART LIST .....34

ORDERING REPLACEMENT PARTS .....35

EXPLODED DRAWING .....36

LIMITED WARRANTY .....Back Cover

## WARNING DECAL PLACEMENT

The decal shown here has been applied in the location shown. **If a decal is missing or illegible, call the telephone number on the front cover of this manual and request a free replacement decal. Apply the decal in the location shown.**  
 Note: The decal may not be shown at actual size.

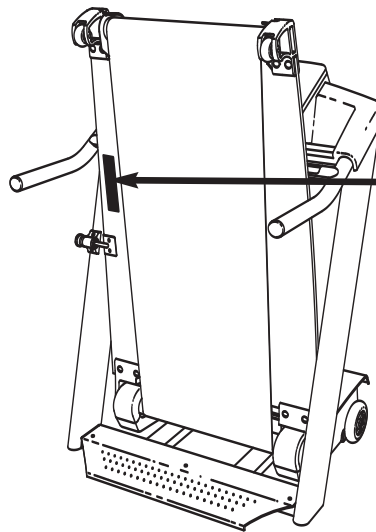

**⚠ WARNING:**

Protect yourself and others from risk of serious injury. Read the user's manual and :

-  •Stand only on the side rails when starting or stopping treadmill.
- Change speed in small increments.
- Hold handrails to prevent falling, and always wear the safety clip while operating treadmill.
- Stop if you feel faint, dizzy, or short of breath.
- Fully engage storage latch before treadmill is moved or stored.
- Reduce incline to its lowest level before folding treadmill into storage position.

-  •Never allow children on or around treadmill.
- Remove key when not in use.

-  •Keep clothing, fingers, and hair away from moving belt.
- Never try to adjust or fix the belt while it is moving.
- Always wear athletic shoes while operating treadmill.

# IMPORTANT PRECAUTIONS

**⚠ WARNING:** To reduce the risk of burns, fire, electric shock, or injury to persons, read the following important precautions and information before operating the treadmill.

1. It is the responsibility of the owner to ensure that all users of this treadmill are adequately informed of all warnings and precautions.
2. Use the treadmill only as described.
3. Place the treadmill on a level surface, with at least eight feet of clearance behind it and two feet on each side. Do not place the treadmill on any surface that blocks air openings. To protect the floor or carpet from damage, place a mat under the treadmill.
4. Keep the treadmill indoors, away from moisture and dust. Do not put the treadmill in a garage or covered patio, or near water.
5. Do not operate the treadmill where aerosol products are used or where oxygen is being administered.
6. Keep children under the age of 12 and pets away from the treadmill at all times.
7. The treadmill should not be used by persons weighing more than 350 pounds.
8. Never allow more than one person on the treadmill at a time.
9. Wear appropriate exercise clothes when using the treadmill. Do not wear loose clothes that could become caught in the treadmill. Athletic support clothes are recommended for both men and women. *Always wear athletic shoes. Never use the treadmill with bare feet, wearing only stockings, or in sandals.*
10. When connecting the power cord (see page 13), plug the power cord into a surge suppressor (not included) and plug the surge suppressor into a grounded circuit capable of carrying 15 or more amps. No other appliance should be on the same circuit. Do not use an extension cord.
11. Use only a single-outlet surge suppressor that meets all of the specifications described on page 13. To purchase a surge suppressor, see your local NordicTrack dealer or call the toll-free telephone number on the front cover of this manual and order part number 146148, or see your local electronics store.
12. Failure to use a properly functioning surge suppressor could result in damage to the control system of the treadmill. If the control system is damaged, the walking belt may change speed, accelerate, or stop unexpectedly, which may result in a fall and serious injury.
13. Keep the power cord and the surge suppressor away from heated surfaces.
14. Never move the walking belt while the power is turned off. Do not operate the treadmill if the power cord or plug is damaged, or if the treadmill is not working properly. (See TROUBLESHOOTING on page 28 if the treadmill is not working properly.)
15. Read, understand, and test the emergency stop procedure before using the treadmill (see HOW TO TURN ON THE POWER on page 15).
16. Never start the treadmill while you are standing on the walking belt. Always hold the handrails while using the treadmill.
17. The treadmill is capable of high speeds. Adjust the speed in small increments to avoid sudden jumps in speed.
18. The pulse sensor is not a medical device. Various factors, including the user's movement, may affect the accuracy of heart rate readings. The pulse sensor is intended only as an exercise aid in determining heart rate trends in general.
19. Never leave the treadmill unattended while it is running. Always remove the key, unplug the power cord, and switch the reset/off circuit breaker to the off position when the treadmill is not in use. (See the drawing on page 6 for the location of the reset/off circuit breaker.)
20. Do not attempt to raise, lower, or move the treadmill until it is properly assembled. (See ASSEMBLY on page 7, and HOW TO FOLD AND MOVE THE TREADMILL on page 26.) You must be able to safely lift 45 pounds (20 kg) to raise, lower, or move the treadmill.

21. Do not change the incline of the treadmill by placing objects under the treadmill.
22. When folding or moving the treadmill, make sure that the frame is held securely by the pin on the latch knob.
23. Inspect and properly tighten all parts of the treadmill regularly.
24. Never insert or drop any object into any opening.
25. **DANGER:** Always unplug the power cord immediately after use, before cleaning the treadmill, and before performing the maintenance and adjustment procedures described in this manual. Never remove the motor hood unless instructed to do so by an authorized service representative. Servicing other than the procedures in this manual should be performed by an authorized service representative only.

26. The treadmill is intended for in-home use only. Do not use the treadmill in any commercial, rental, or institutional setting.
27. To reduce the risk of electric shock, do not remove the cover or the back of the television. There are no user serviceable parts inside. Refer servicing to qualified service personnel.
28. Upon completion of any service or repairs to the treadmill or the television, ask the service technician to perform safety checks to confirm that the unit is in proper operating condition.

**Note to CATV system installer:** This reminder is provided to call the CATV system installer's attention to Article 820-40 of the NEC that provides guidelines for proper grounding and, in particular, specifies that the cable ground shall be connected to the grounding system of the building, as close to the point of cable entry as practical.

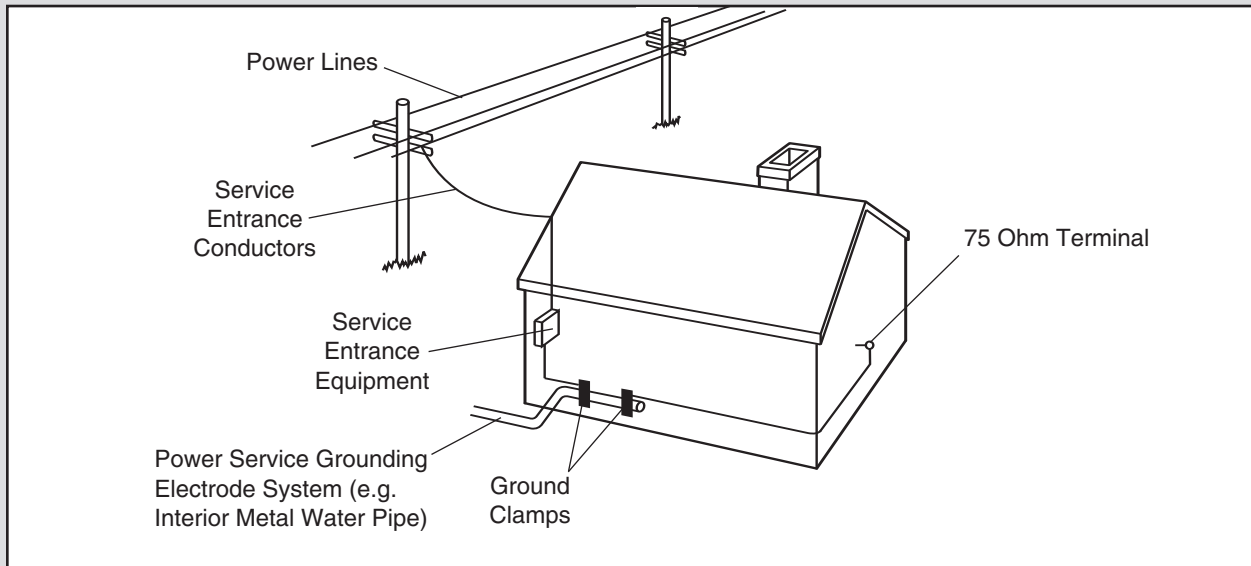

**⚠ WARNING:** Before beginning this or any exercise program, consult your physician. This is especially important for persons over the age of 35 or persons with pre-existing health problems. Read all instructions before using. ICON assumes no responsibility for personal injury or property damage sustained by or through the use of this product.

**SAVE THESE INSTRUCTIONS**

# BEFORE YOU BEGIN

Thank you for selecting the revolutionary NordicTrack® VIEWPOINT 8500 treadmill. The VIEWPOINT 8500 treadmill offers a selection of features designed to make your workouts at home more enjoyable and effective. And when you're not exercising, the unique VIEWPOINT 8500 treadmill can be folded up, requiring less than half the floor space of other treadmills.

**For your benefit, read this manual carefully before using the treadmill.** If you have questions after read-

ing this manual, please see the front cover of this manual. To help us assist you, note the product model number and serial number before contacting us. The model number of the treadmill is NTL22907.1. The serial number can be found on a decal attached to the treadmill (see the front cover of this manual for the location).



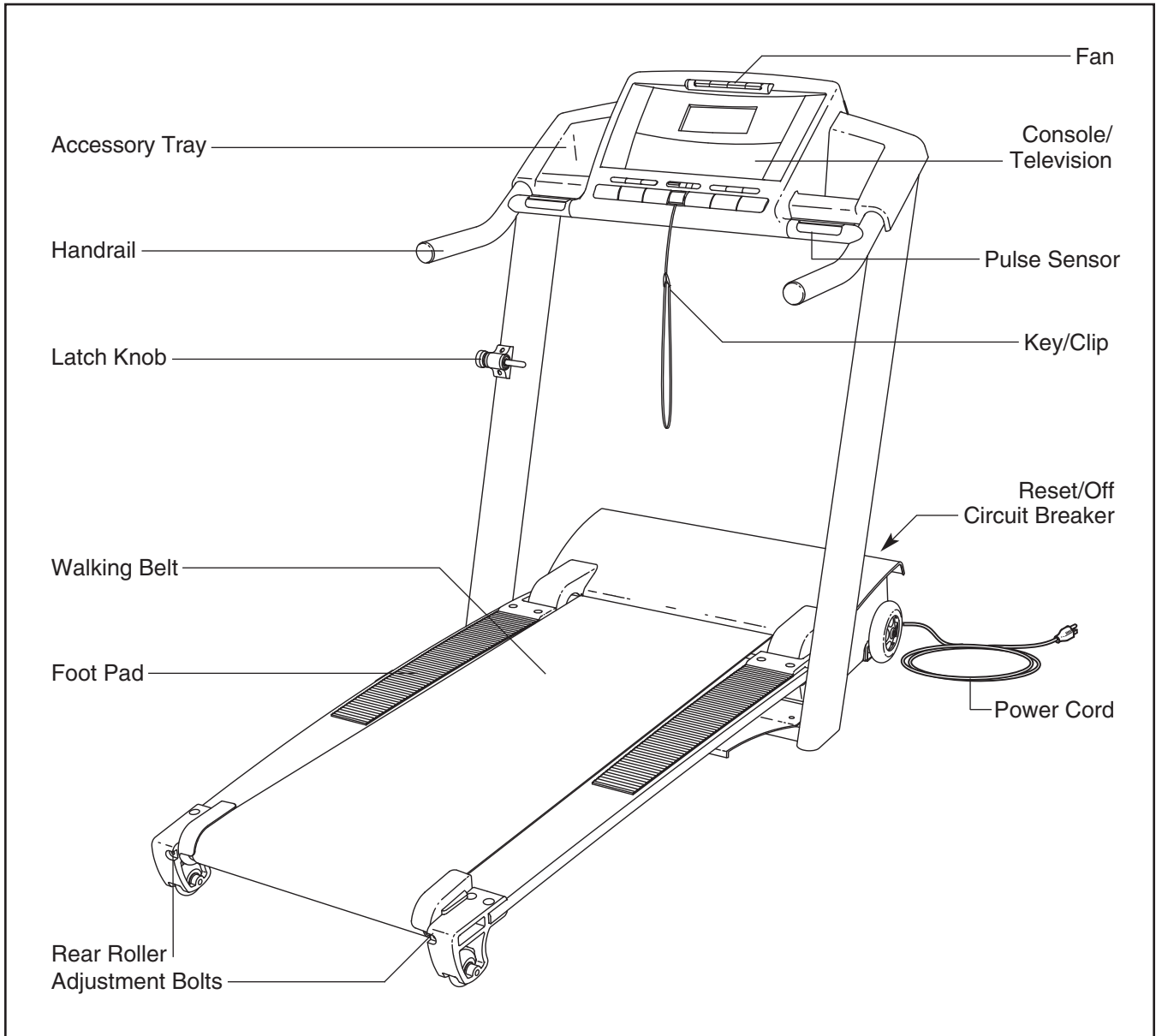

Before reading further, please familiarize yourself with the parts that are labeled in the drawing below.



# ASSEMBLY

**Assembly requires two persons.** Set the treadmill in a cleared area and remove all packing materials. **Do not dispose of the packing materials until assembly is completed.**

Note: The underside of the treadmill walking belt is coated with high-performance lubricant. During shipping, a small amount of lubricant may be transferred to the top of the walking belt or the shipping carton. This is a normal condition and does not affect treadmill performance. If there is lubricant on top of the walking belt, simply wipe off the lubricant with a soft cloth and a mild, non-abrasive cleaner.

**Assembly requires the included hex key  and your own phillips screwdriver , standard screwdriver , and rubber mallet .** For help identifying the assembly hardware, see the drawings below. The number in parentheses below each drawing is the key number of the part, from the PART LIST near the end of this manual. The number following the parentheses is the quantity needed for assembly. **Note: Some small parts may have been preassembled. If a part is not in the parts bag, check to see if it has been preassembled. To avoid damaging plastic parts, do not use power tools for assembly. Extra hardware may be included.**

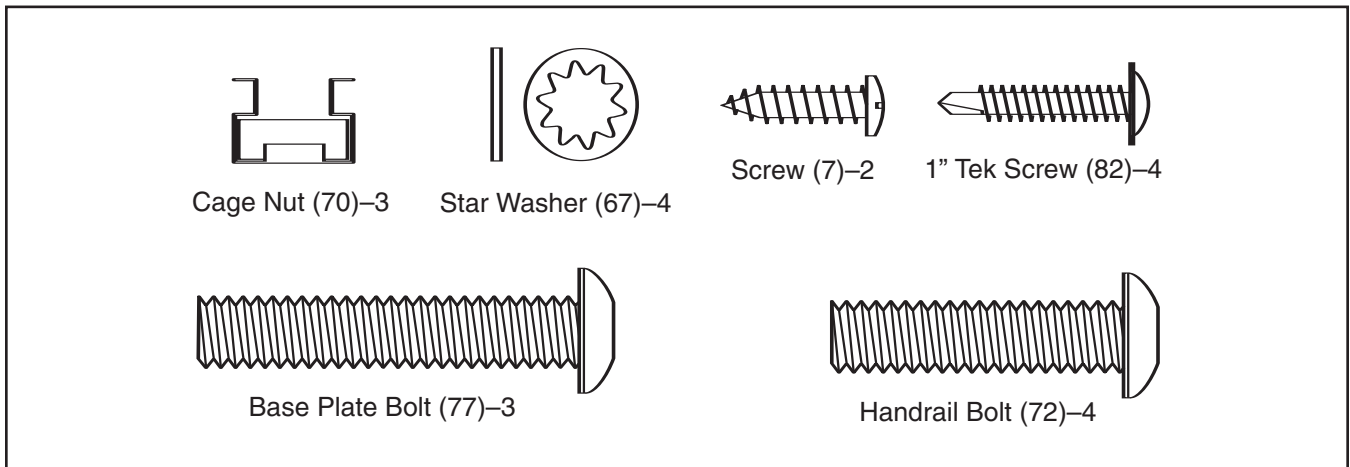

1. With the help of a second person, tip the Uprights (20) down as shown.

Insert the three Cage Nuts (70) into the three indicated holes in the treadmill. To insert each Cage Nut, first hook one side of the Cage Nut into a hole. Then, use a standard screwdriver to press the other side of the Cage Nut into the hole, as shown.

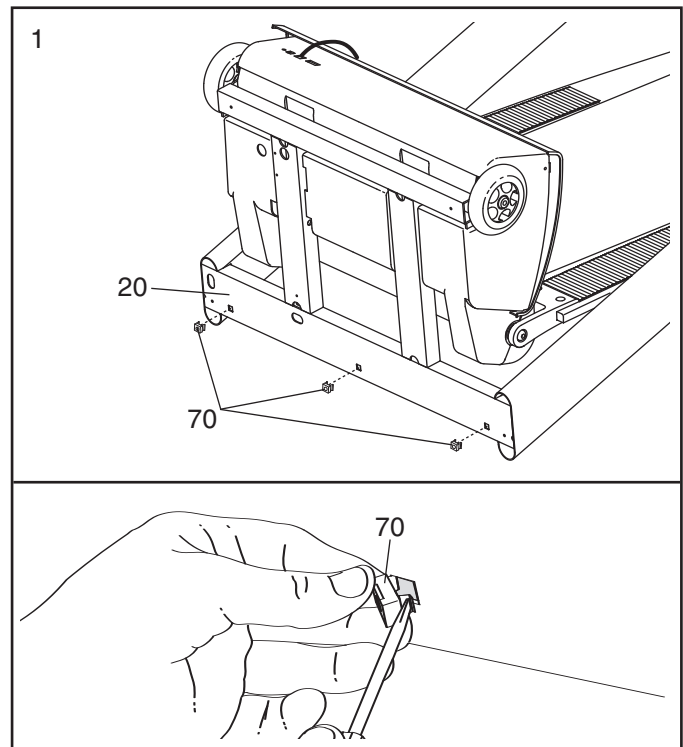

2. Attach the four Base Pads (81) to the base of the Uprights (20) with four 1" Tek Screws (82) in the locations shown.

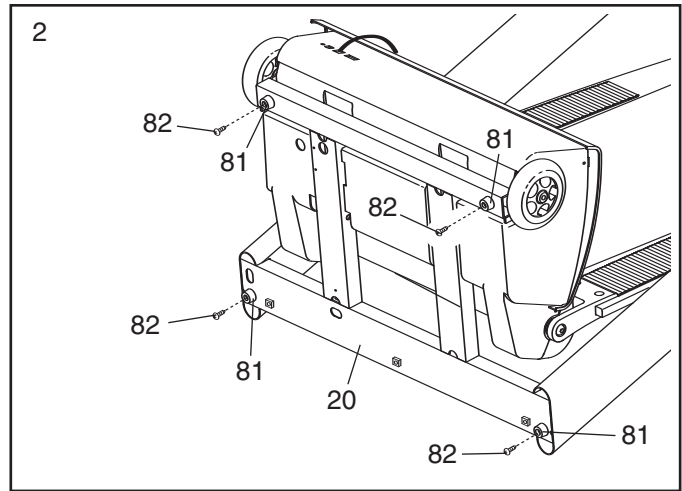

3. With the help of a second person, carefully raise the Uprights (20) to the vertical position. Remove the band securing the Upright Wire Harness (73) to the right Upright. Have a second person hold the console assembly near the right Upright.

Connect the Upright Wire Harness (73) to the console wire extending from the console assembly. **See the inset drawing. The connectors should slide together easily and snap into place.** If they do not, turn one connector and try again. **IF THE CONNECTORS ARE NOT CONNECTED PROPERLY, THE CONSOLE MAY BE DAMAGED WHEN THE POWER IS TURNED ON.** Then, insert the connectors into the right Upright (20).

Connect the TV Cable (not shown) in the left Upright (not shown) to the cable extending from the console assembly.

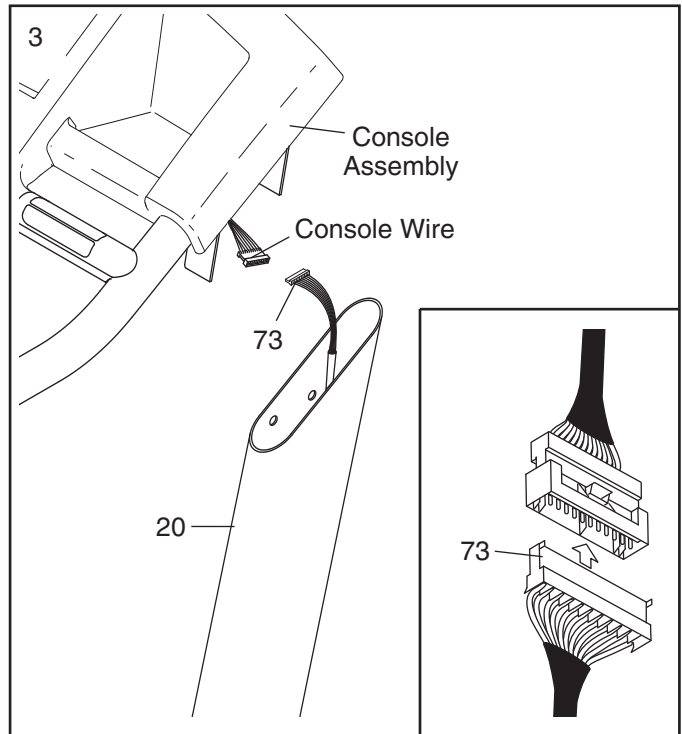

4. Connect the TV Cable (117) in the left Upright (20) to the cable extending from the console assembly.

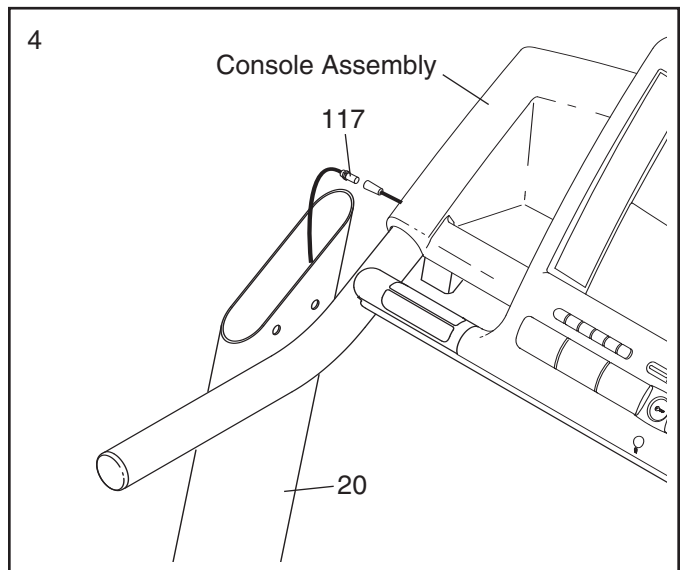



- Carefully set the console assembly on the Uprights (20) as shown. **Make sure that no wires are pinched.** Attach the console assembly with four Star Washers (67) and four Handrail Bolts (72). **Start all four Handrail Bolts and then tighten them.**

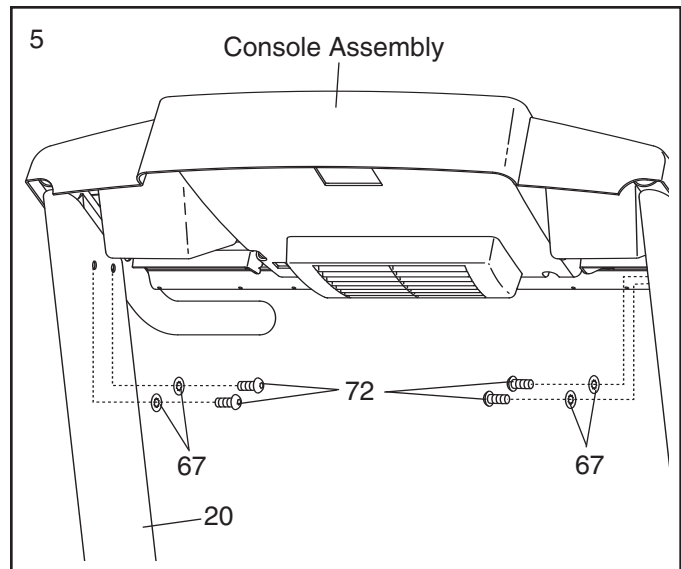

- Attach the Latch Housing (34) to the left Upright (20) with two Screws (7); **start both Screws and then tighten them. Make sure that the large hole in the Latch Housing is on the indicated side.**

Remove the knob from the pin. Make sure that the collar and the spring are on the pin. (Note: If there are two collars, place one on each side of the spring.) Next, insert the pin into the Latch Housing (34). Then, tighten the knob onto the pin.

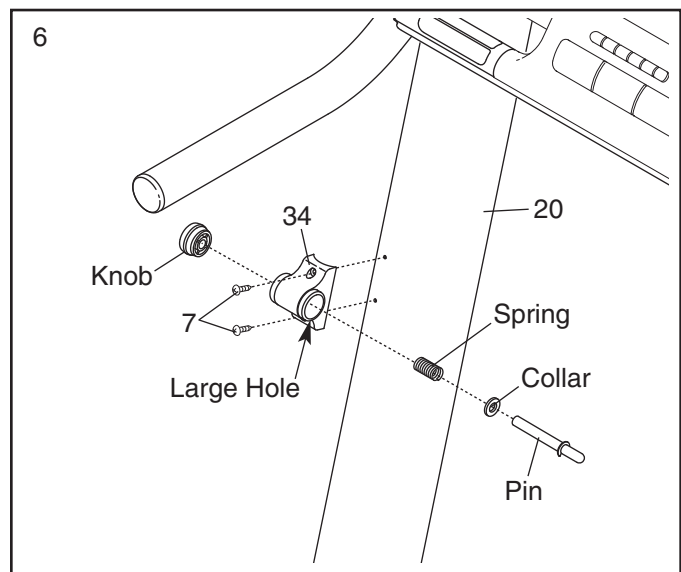

- With the help of a second person, raise the Walking Platform (15) to the storage position and make sure that the latch pin is engaged as described on page 26.

Position the Base Plate (75) on the treadmill as shown. Attach the Base Plate to the Uprights (20) with three Base Plate Bolts (77). Note: It may be helpful if a second person tips the treadmill slightly as you tighten the Base Plate Bolts.

Carefully lower the Walking Platform (15) to the floor as described on page 27.

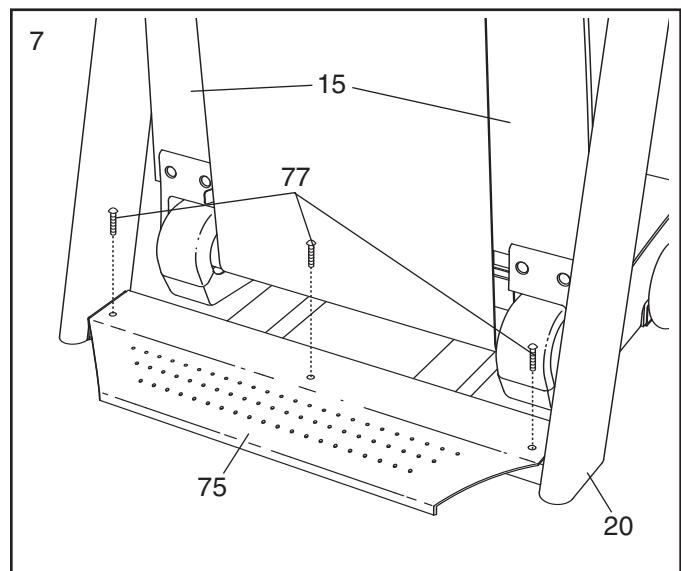

8. Note the location of the 75 ohm terminal on the treadmill. For the television to operate, an audio/video wire must be connected to the audio/video input jack on the back of the console, a personal audio/video player must be connected to the audio/video plug on the console, or a CATV cable must be connected to the 75 ohm terminal (see page 12).

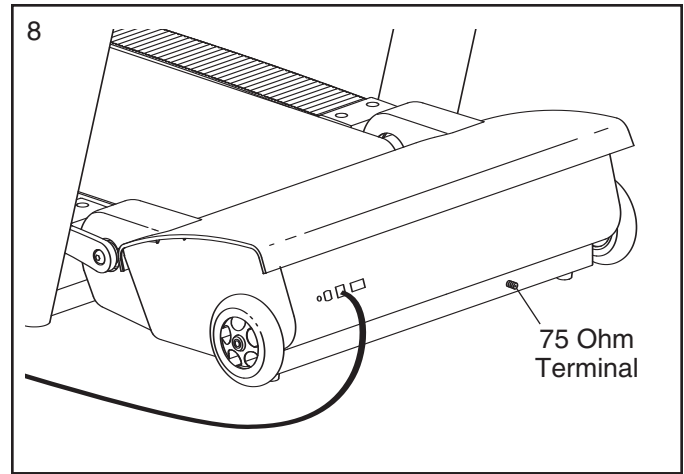

9. **Make sure that all parts are properly tightened before you use the treadmill.** Keep the included hex key in a secure place. The hex key is used to adjust the walking belt (see page 29). **To protect the floor or carpet from damage, place a mat under the treadmill.**

If you purchase the optional chest pulse sensor (see page 25), follow the steps below to install the receiver included with the chest pulse sensor.

1. **Make sure that the power cord is unplugged.** Remove the indicated Screws (7) from the back of the Console Base (98).

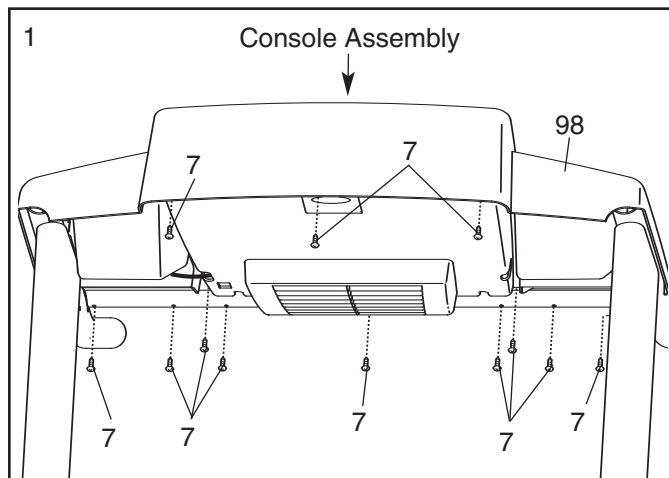

2. While a second person holds the console assembly, connect the wire on the receiver (A) to the indicated wire extending from the Console. **Next, hold the receiver so the small cylinder is oriented as shown and is facing away from the Console.** Attach the receiver to the Console in the location shown with the two included Small Screws (B).

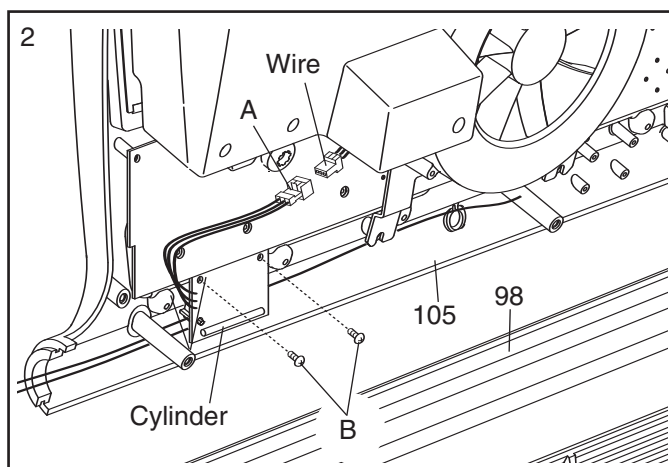

3. **Make sure that no wires are pinched.** See drawing 1. Reattach the Console (105) to the Console Base (98) with the Screws (99). Discard the other wires included with the receiver.

**Before operating the television, you must connect a 75 ohm CATV cable to the 75 ohm terminal on the treadmill, a VCR or DVD player to the audio/video input jack, or a personal audio/video player to the audio/video plug below the television on the console. Note: Use CATV cable to connect to an external source such as a cable box, analog cable, satellite TV box, or VCR. No CATV cable or audio/video wire is included.**

#### **HOW TO CONNECT A 75 OHM CATV CABLE**

1. Connect a 75 ohm CATV cable to the 75 ohm terminal on the treadmill frame near the power cord.

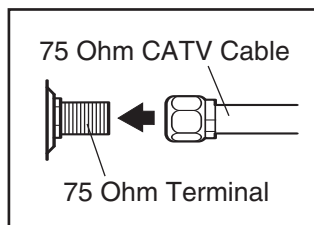

#### **HOW TO CONNECT A DVD PLAYER OR VCR USING THE AUDIO/VIDEO INPUT JACK**

1. Connect one end of an audio/video wire to your DVD player or VCR.
2. Plug in the power cord of your DVD player or VCR. See your DVD player or VCR user's manual for proper grounding instructions.
3. Connect the audio/video wire to the audio/video input jack on the back of the console base.

#### **HOW TO CONNECT AN EXTERNAL SOURCE USING A CATV CABLE**

1. Connect one end of a 75 ohm CATV cable to the video output jack on your external source.
2. Plug in the power cord of your external source. See your external source's user's manual for proper grounding instructions.
3. Connect the 75 ohm CATV cable to the 75 ohm terminal on the treadmill frame near the power cord.

#### **HOW TO CONNECT A PERSONAL AUDIO/VIDEO PLAYER DIRECTLY TO THE CONSOLE**

Locate the audio/video plug below the television on the console, and plug it into a jack on your MP3 player, CD player, or personal audio/video player.

# OPERATION AND ADJUSTMENT

## THE PRE-LUBRICATED WALKING BELT

Your treadmill features a walking belt coated with high-performance lubricant. **IMPORTANT: Never apply silicone spray or other substances to the walking belt or the walking platform. Such substances will deteriorate the walking belt and cause excessive wear.**

## HOW TO PLUG IN THE POWER CORD

**⚠ DANGER:** Improper connection of the equipment-grounding conductor can result in an increased risk of electric shock. Check with a qualified electrician or serviceman if you are in doubt as to whether the product is properly grounded. Do not modify the plug provided with the product—if it will not fit the outlet, have a proper outlet installed by a qualified electrician.

Your treadmill, like any other type of sophisticated electronic equipment, can be seriously damaged by sudden voltage changes in your home's power. Voltage surges, spikes, and noise interference can result from weather conditions or from other appliances being turned on or off. **To decrease the possibility of your treadmill being damaged, always use a surge suppressor with your treadmill (see drawing 1 at the right).** To purchase a surge suppressor, see your local NordicTrack dealer or call the toll-free telephone number on the front cover of this manual and order part number 146148, or see your local electronics store.

Use only a single-outlet surge suppressor that is UL 1449 listed as a transient voltage surge suppressor (TVSS). The surge suppressor must have a UL suppressed voltage rating of 400 volts or less and a minimum surge dissipation of 450 joules. The surge suppressor must be electrically rated for 120 volts AC and 15 amps. There must be a monitoring light on the surge suppressor to indicate whether it is functioning properly. Failure to use a properly functioning surge suppressor could result in damage to the control system of the treadmill. If the control system is damaged, the walking belt may change speed, accelerate, or stop unexpectedly, which may result in a fall and serious injury.

**This product must be grounded.** If it should malfunction or break down, grounding provides a path of least resistance for electric current to reduce the risk of elec-

tric shock. This product is equipped with a cord having an equipment-grounding conductor and a grounding plug. **Plug the power cord into a surge suppressor, and plug the surge suppressor into an appropriate outlet that is properly installed and grounded in accordance with all local codes and ordinances. Important: The treadmill is not compatible with GFCI-equipped outlets.**

This product is for use on a nominal 120-volt circuit, and has a grounding plug that looks like the plug illustrated in drawing 1 below. A temporary adapter that looks like the adapter illustrated in drawing 2 may be used to connect the surge suppressor to a 2-pole receptacle as shown in drawing 2 if a properly grounded outlet is not available.

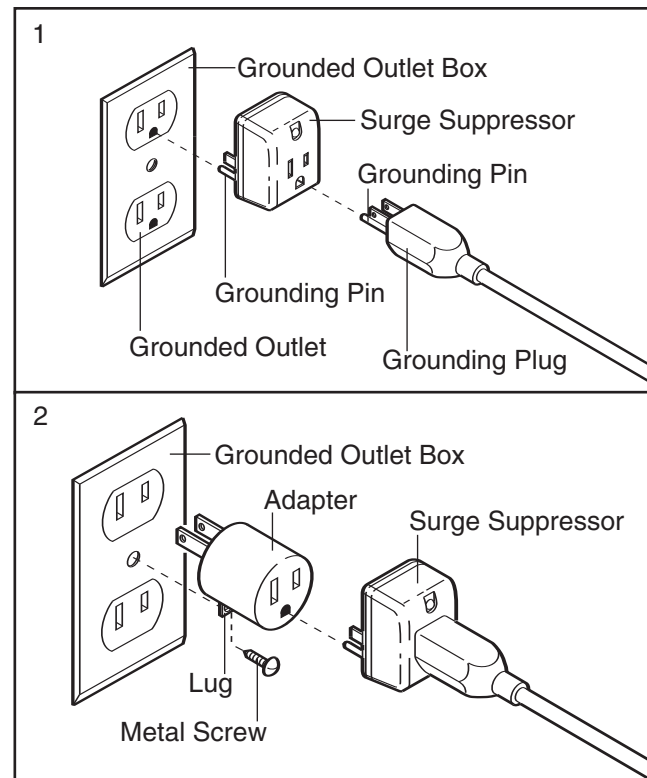

The temporary adapter should be used only until a properly grounded outlet (drawing 1) can be installed by a qualified electrician.

The green-colored rigid ear, lug, or the like extending from the adapter must be connected to a permanent ground such as a properly grounded outlet box cover. Whenever the adapter is used it must be held in place by a metal screw. **Some 2-pole receptacle outlet box covers are not grounded. Contact a qualified electrician to determine if the outlet box cover is grounded before using an adapter.**

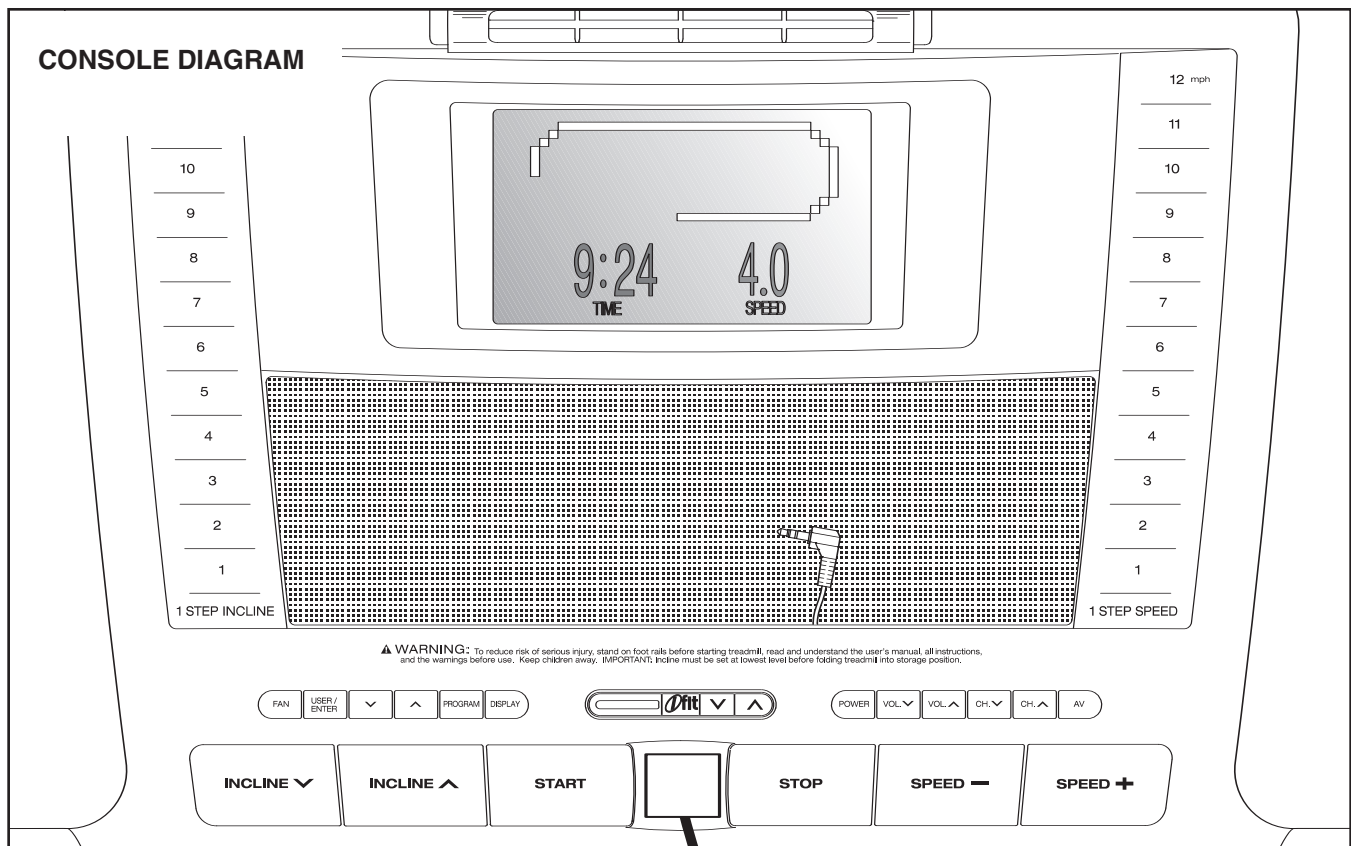

## FEATURES OF THE CONSOLE

The treadmill console offers an impressive array of features designed to make your workouts more effective and enjoyable. When you select the manual mode of the console, you can change the speed and incline of the treadmill with the touch of a button. As you exercise, the screen will display continuous exercise feedback. You can even measure your heart rate using the handgrip pulse sensor or the optional chest pulse sensor (see page 25).

In addition, the console features fourteen preset programs. Each program automatically controls the speed and incline of the treadmill as it guides you through an effective workout. The console also offers four pulse programs that control the speed and incline of the treadmill to help you keep your heart rate near target heart rate settings. You can even create your own custom programs and save them for future use. **Note: The pulse programs require the use of the optional chest pulse sensor.**

The console also features the new iFIT Interactive Workout system. The iFIT system is compatible with iFIT Interactive Workout Cards containing workout programs designed to help you achieve specific fitness goals. For example, lose unwanted pounds with the Weight Loss program, or train for a long-distance run with the Marathon program. iFIT programs automatically control the treadmill while the voice of a personal

trainer coaches and motivates you through every step of your workout. One demo iFIT Card is included. Additional iFIT Cards are available separately. **To purchase iFIT Cards at any time, go to [www.iFIT.com](http://www.iFIT.com) or call the toll-free telephone number on the front cover of this manual. iFIT Cards are also available at select stores.**

Whether you select the manual mode or a program, you can enjoy the shows of your choice on the personal television while you get in shape. You can even listen to your favorite workout music or audio books with the console's stereo sound system.

**To turn on the power,** see page 15. **To use the manual mode,** follow the steps beginning on page 15. **To use a preset program,** see page 17. **To use a pulse program,** see page 18. **To create and use a custom program,** see pages 20 and 21. **To use an iFIT card,** see page 22. **To operate the personal television,** see page 23. **To use the stereo sound system,** see page 23.

**IMPORTANT: If there is a sheet of clear plastic on the face of the console, remove the plastic. To prevent damage to the walking platform, wear clean athletic shoes while using the treadmill. The first time the treadmill is used, observe the alignment of the walking belt, and center the walking belt if necessary (see page 26).**

## HOW TO TURN ON THE POWER

**IMPORTANT:** If the treadmill has been exposed to cold temperatures, allow it to warm to room temperature before turning on the power. If you do not do this, the console displays or other electrical components may become damaged.

Plug in the power cord (see page 13). Next, locate the reset/off circuit breaker on the treadmill frame near the power cord. Make sure that the circuit breaker is in the reset position.

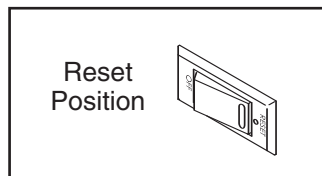

Next, stand on the foot rails of the treadmill. Find the clip attached to the key, and slide the clip securely onto the waistband of your clothes. Then, insert the key into the console. After a moment, the screen will light, and after a few seconds, the console will turn on. **Important:** In an emergency situation, the key can be pulled from the console, causing the walking belt to slow to a stop. Test the clip by carefully taking a few steps backward; if the key is not pulled from the console, adjust the position of the clip.

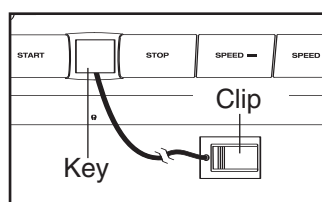

## HOW TO USE THE MANUAL MODE

### 1 Insert the key into the console.

See HOW TO TURN ON THE POWER above.

### 2 Designate yourself as user 1 or user 2.

The console can save settings for two different users. To designate yourself as user 1 or user 2, first press the User button; the words USER: 1 or USER: 2 will appear on the screen for a few seconds. Press the increase or decrease button beside the User button to change the designation if desired. When you designate yourself as user 1 or user 2, any settings that you have previously made will automatically be selected.

To change user settings, press the User button again while the words USER: 1 or USER: 2 ap-

pear; the words ODOMETER and TOTAL ODOMETER will appear on the screen for a few seconds. The top number is the number of miles or kilometers that the user has walked or run since the number was reset. To reset the number, press the decrease button beside the User button. The bottom number is the total number of miles or kilometers that the user has walked or run. This number cannot be reset.

Press the User button again; the word WEIGHT and a weight setting will appear on the screen. To enter your weight, press the increase and decrease buttons beside the User button.

After a few seconds, the screen will return to the manual mode.

### 3 Select the manual mode.

Each time the key is inserted, the manual mode will be selected. If you have selected a program, remove the key and then reinsert it.

### 4 Start the walking belt and adjust the speed.

To start the walking belt, press the Start button, the Speed + button, or one of the 1 Step Speed buttons.

If the Start button or the Speed + button is pressed, the walking belt will begin to move at 1 mph. As you exercise, change the speed of the walking belt as desired by pressing the Speed + and - buttons. Each time a button is pressed, the speed setting will change by 0.1 mph; if a button is held down, the speed setting will change in increments of 0.5 mph. If one of the 1 Step Speed buttons is pressed, the walking belt will gradually increase in speed until it reaches the selected speed setting.

To stop the walking belt, press the Stop button. To restart the walking belt, press the Start button, the Speed + button, or one of the 1 Step Speed buttons.

### 5 Change the incline of the treadmill as desired.

To change the incline of the treadmill, press the Incline increase and decrease buttons or one of the 1 Step Incline buttons.

Each time the Incline increase or decrease button is pressed, the incline will change by 0.5%. If one of the 1 Step Incline buttons is pressed, the incline will gradually increase until it reaches the selected incline setting.



**6** Select a display mode and follow your progress with the exercise information on the screen.

As you walk or run on the treadmill, the screen can display the following exercise information:

- The elapsed time. Note: When a program is selected, the screen will show the time remaining in the program instead of the elapsed time.
- The distance that you have walked or run. Note: The console can display distance and speed in either miles or kilometers (see HOW TO USE THE INFORMATION MODE on page 24). **For simplicity, all instructions in this section refer to miles.**
- The speed of the walking belt.
- The approximate number of calories you have burned.
- The incline level of the treadmill. Note: The incline level of the treadmill will be displayed only when you press Incline buttons.
- The approximate number of grams of carbs you have burned.
- Your heart rate. Note: Your heart rate will be displayed only when you use the handgrip pulse sensor or the optional chest pulse sensor.
- When the manual mode is selected, the screen can show a track that represents 1/4 mile (400 meters). As you walk or run on the treadmill, segments of the track will appear in succession until the entire track appears. The track will then disappear and the segments will again begin to appear in succession.

While the television is turned off, you can select either of two display modes: the screen can display the track and some exercise information, or the screen can display all the exercise information. While the television is turned on, you can select any of three display modes: exercise information can be displayed at the bottom of the screen or on the right side of the screen, or the information can be turned off while you watch the television. Press the Display button repeatedly to select the desired display mode.

To reset the console, press the Stop button, remove the key, and then reinsert the key.

**7** Measure your heart rate if desired.

**Note: If you use the handgrip pulse sensor and the optional chest pulse sensor at the same time, the display will not show your heart rate accurately.**

To use the handgrip pulse sensor, first remove the sheets of clear plastic from the metal contacts on the handgrip pulse sensor.

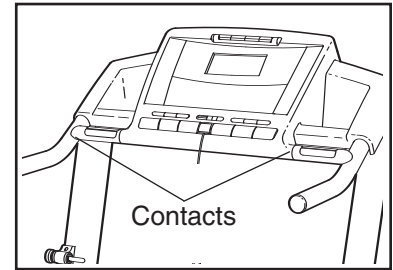

Next, **stand on the foot rails** and hold the metal contacts—**avoid moving your hands**. When your pulse is detected, your heart rate will appear on the screen. **For the most accurate heart rate reading, continue to hold the contacts for about 15 seconds.**

**8** Turn on the fan if desired.

To turn on the fan at high speed, press the Fan button. To turn on the fan at low speed, press the button a second time. To select the auto mode, press the button a third time. When the auto mode is selected, the speed of the fan will automatically increase or decrease as the speed of the walking belt increases or decreases.

To turn off the fan, press the Fan button again. Note: If the fan is on when the walking belt stops, the fan will automatically turn off after a few minutes.

**9** When you are finished exercising, remove the key.

Step onto the foot rails, press the Stop button, and adjust the incline of the treadmill to the lowest setting. **The incline must be at the lowest setting when you fold the treadmill to the storage position or you may damage the treadmill.** Next, remove the key from the console and put it in a secure place.

**When you are finished using the treadmill, switch the reset/off circuit breaker to the “off” position and unplug the power cord.**



## HOW TO USE A PRESET PROGRAM

### 1 Insert the key into the console.

See HOW TO TURN ON THE POWER on page 15.

### 2 Identify yourself as user 1 or user 2.

See step 2 on page 15.

### 3 Select one of the fourteen preset programs.

To select a preset program, press the Program button repeatedly; the name of the program that you have selected (PROGRAM 1 through PROGRAM 14) will appear on the screen.

When a preset program is selected, the maximum speed and incline settings of the program, the program time, and a profile of the speed settings of the program will appear on the screen. The arrow below the profile will show your progress during the workout.

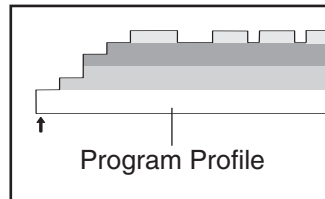

### 4 Press the Start button to start the program.

A moment after the button is pressed, the treadmill will automatically adjust to the first speed and incline settings of the program. Hold the handrails and begin walking.

Each program is divided into several one-minute segments. One speed setting and one incline setting are programmed for each segment. Note: The same speed setting and/or incline setting may be programmed for two or more consecutive segments.

When the first segment of the program ends, a series of tones will sound. If the speed and/or incline of the treadmill is about to change, the new speed setting and/or incline setting will appear on the screen to alert you. The arrow below the program profile will

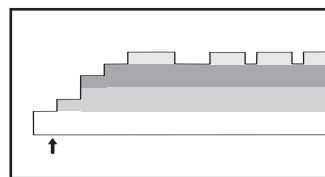

then move one position to the right, and the treadmill will automatically adjust to the speed and incline settings programmed for the second segment. Note: The screen has a Console mode and a Tuner mode. The program profile can be displayed only while the Console mode is selected. To view the program profile, press the Power button repeatedly until the word CONSOLE appears on the screen for a few seconds.

The program will continue in this way until the arrow reaches the right end of the program profile. The walking belt will then slow to a stop.

If the speed settings and/or incline settings are too high or too low, you can override the settings by pressing the Speed and/or Incline buttons; however, when the next segment begins, **the treadmill will automatically adjust to the speed and incline settings programmed for the next segment.**

To stop the program at any time, press the Stop button. To restart the program, press the Start button. The walking belt will begin to move at 1 mph. When the next segment of the program begins, the treadmill will automatically adjust to the speed and incline settings programmed for the next segment.

### 5 Select a display mode and follow your progress with the exercise information on the screen.

See step 6 on page 16.

### 6 Measure your heart rate if desired.

See step 7 on page 16.

### 7 Turn on the fan if desired.

See step 8 on page 16.

### 8 When you are finished exercising, remove the key from the console.

When the program ends, **make sure that the incline of the treadmill is at the lowest setting.** Next, remove the key from the console and put it in a safe place.

**When you are finished using the treadmill, switch the reset/off circuit breaker to the "off" position and unplug the power cord.**

## HOW TO USE A PULSE PROGRAM

**⚠ CAUTION:** If you have heart problems, or if you are over 60 years of age and have been inactive, do not use the pulse programs. If you are taking medication regularly, consult your physician to find whether the medication will affect your exercise heart rate.

Follow the steps below to use a pulse program.

### 1 Put on the optional chest pulse sensor.

Note: You must wear the optional chest pulse sensor to use a pulse program.

### 2 Insert the key into the console.

See HOW TO TURN ON THE POWER on page 15.

### 3 Identify yourself as user 1 or user 2.

See step 2 on page 15.

### 4 Select one of the four pulse programs.

To select a pulse program, press the Program button repeatedly. When a pulse program is selected, the name of the program (PULSE: 1, PULSE: 2, PULSE: 3, or PULSE: 4) will appear on the screen.

**If pulse program 1 is selected**, a track will appear on the screen.

**If pulse program 2, 3, or 4 is selected**, a profile of the heart rate settings of the program will appear on the screen. The arrow below the profile will indicate your progress during the workout.

### 5 Enter a target heart rate setting.

**If pulse program 1 is selected**, the target heart rate setting for the entire program will appear on the screen beside the words TARGET BPM (beats per minute). If desired, press the increase and decrease buttons beside the User button to change the target heart rate setting (see EXERCISE INTENSITY on page 31).

**If pulse program 2, 3, or 4 is selected**, the maximum target heart rate setting of the program will appear on the screen. If desired, press the increase and decrease buttons beside the User button to change the maximum target heart rate setting (see EXERCISE INTENSITY on page 31). Note: If you change the maximum target heart rate setting, the intensity level of the entire program will change.

### 6 Press the Start button to start the program.

A moment after the button is pressed, the treadmill will automatically adjust to the first speed and incline settings of the program. Hold the handrails and begin walking.

Pulse program 1 is divided into one-minute segments. The same target heart rate setting is programmed for all segments (except for the first two segments). Pulse programs 2, 3, and 4 are divided into 30 one-minute segments. One target heart rate setting is programmed for each segment. Note: The same target heart rate setting may be programmed for two or more consecutive segments.

During each segment of the program, the console will compare your heart rate to the target heart rate setting for that segment. If your heart rate is too far below or above the target heart rate setting, the speed and/or incline will automatically increase or decrease to bring your heart rate closer to the target heart rate setting. Each time the speed and/or incline of the treadmill is about to change, the speed setting and/or incline setting will flash on the screen to alert you, regardless of which display mode is selected.

**If pulse program 2, 3, or 4 is selected**, a series of tones will sound when the first segment of the program ends. The arrow below the program profile will then move one position to the right. The program will continue in this way until the arrow reaches the right end of the program profile. The walking belt will then slow to a stop.

If the speed settings and/or incline settings are too high or too low, you can change the intensity level of the program at any time by pressing the increase and decrease buttons beside the User button to change the target heart rate setting or the maximum target heart rate setting.

To stop the program at any time, press the Stop button. To restart the program, press the Start button. The walking belt will begin to move at 1 mph. When the console compares your heart rate to the target heart rate setting for the current segment of the program, the speed and/or incline of the treadmill will automatically change to bring your heart rate closer to the target heart rate setting.

**7** **Select a display mode and follow your progress with the exercise information on the screen.**

See step 6 on page 16.

**8** **Turn on the fan if desired.**

See step 8 on page 16.

**9** **When you are finished exercising, remove the key from the console.**

See step 8 on page 17.

## HOW TO CREATE A CUSTOM PROGRAM

### **1** Insert the key into the console.

See HOW TO TURN ON THE POWER on page 15.

### **2** Identify yourself as user 1 or user 2.

See step 2 on page 15.

### **3** Select one of the four custom programs.

To select a custom program, press the Program button repeatedly. When a custom program is selected, the name of the program (CUSTOM: 1, CUSTOM: 2, CUSTOM: 3, or CUSTOM: 4) will appear on the screen.

**Note: If the custom program has not yet been designed, a workout time of three minutes will appear on the screen. If the workout time is more than three minutes, see HOW TO USE A CUSTOM PROGRAM on page 21.**

### **4** Press the Start button and program the desired speed and incline settings.

A moment after the button is pressed, the walking belt will begin to move. Hold the handrails and begin walking.

Each custom program is divided into one-minute segments. One speed setting and one incline setting can be programmed for each segment. To program a speed setting and an incline setting for the first segment, simply adjust the speed and incline of the treadmill as desired by pressing the Speed and Incline buttons.

When the first segment of the program ends, a series of tones will sound and the current speed setting and the current incline setting will be saved in memory. Program a speed setting and an incline setting for the second segment as described above.

Continue programming speed and incline settings for as many segments as desired; custom programs can have up to forty segments. When you are finished with your workout, press the Stop button twice. The speed and incline settings that you have programmed and the program time will then be saved in memory.

### **5** Select a display mode and follow your progress with the exercise information on the screen.

See step 6 on page 16.

### **6** Measure your heart rate if desired.

See step 7 on page 16.

### **7** Turn on the fan if desired.

See step 8 on page 16.

### **8** When you are finished exercising, remove the key from the console.

See step 8 on page 17.

## HOW TO USE A CUSTOM PROGRAM

### 1 Insert the key into the console.

See HOW TO TURN ON THE POWER on page 15.

### 2 Identify yourself as user 1 or user 2.

See step 2 on page 15.

### 3 Select one of the four custom programs.

To select a custom program, press the Program button repeatedly. When a custom program is selected, the name of the program (CUSTOM: 1, CUSTOM: 2, CUSTOM: 3, or CUSTOM: 4) will appear on the screen.

In addition, the maximum speed and incline settings of the program, the program time, and a profile of the speed settings of the program will appear. **Note: If the workout time is only three minutes, see HOW TO CREATE A CUSTOM PROGRAM on page 20.**

### 4 Press the Start button or the Speed increase button to start the program.

A moment after the button is pressed, the treadmill will automatically adjust to the first speed and incline settings that you programmed previously. Hold the handrails and begin walking.

Each custom program is divided into several one-minute segments. One speed setting and one incline setting are programmed for each segment. Note: The same speed setting and/or incline setting may be programmed for two or more consecutive segments.

The custom program will function in the same way as a preset program (see step 4 on page 17).

If desired, you can redesign the program while using it. **To change the speed setting or the incline setting for the current segment**, simply press the Speed or Incline buttons. When the current segment ends, the new setting will be saved in memory. **To increase the length of the program**, first wait until the program is completed. Then, press the Start button and program speed and incline settings for as many additional segments as desired. When you have added as many segments as desired, press the Stop button twice. **To decrease the length of the program**, press the Stop button twice at any time before the program is completed.

To stop the program temporarily, press the Stop button. To restart the program, press the Start button. The walking belt will begin to move at 1 mph. When the next segment of the program begins, the treadmill will automatically adjust to the speed and incline settings programmed for the next segment.

### 5 Select a display mode and follow your progress with the exercise information on the screen.

See step 6 on page 16.

### 6 Measure your heart rate if desired.

See step 7 on page 16.

### 7 Turn on the fan if desired.

See step 8 on page 16.

### 8 When you are finished exercising, remove the key from the console.

See step 8 on page 17.

## HOW TO USE AN iFIT CARD

### 1 Insert the key into the console.

See HOW TO TURN ON THE POWER on page 15.

### 2 Identify yourself as user 1 or user 2.

See step 2 on page 15.

### 3 Insert an iFIT Card and select a program.

To use an iFIT program, insert an iFIT Card into the iFIT slot; **make sure that the iFIT Card is oriented so the metal contacts are face down and are inside the iFIT slot.**

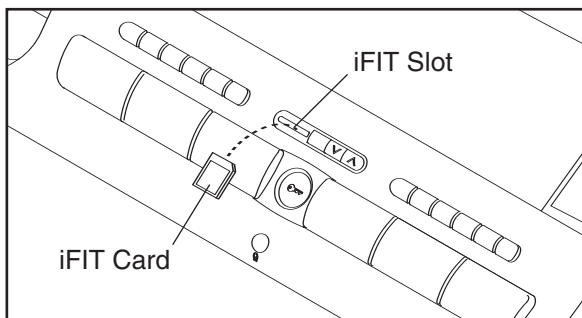

Next, select an iFIT program by pressing the increase and decrease buttons next to the iFIT indicator. When an iFIT program is selected, the display will show the name of the program, the maximum incline and speed settings of the program, and the program time. In addition, a profile of the speed settings of the program will appear on the screen.

Each program is divided into several one-minute segments. One speed setting and one incline setting are programmed for each segment. Note: The same speed setting and/or incline setting may be programmed for two or more consecutive segments.

### 4 Press the Start button to start the program.

A moment after the button is pressed, the treadmill will automatically adjust to the first speed and incline settings of the program. Hold the handrails and begin walking.

During the program, the voice of a personal trainer will guide you through the workout. Note: If the AUDIO TRAINER: OFF setting is selected (see step 1 on page 24), the personal trainer's voice will not be heard.

If the speed settings and/or incline settings are too high or too low, you can override the settings by pressing the Speed and/or Incline buttons; however, when the next segment of the program begins, **the treadmill will automatically adjust to the speed and incline settings programmed for the next segment.**

To stop the program at any time, press the Stop button. To restart the program, press the Start button. The walking belt will begin to move at 1 mph. When the next segment of the program begins, the treadmill will automatically adjust to the speed and incline settings programmed for the next segment.

### 5 Select a display mode and follow your progress with the exercise information on the screen.

See step 6 on page 16.

### 6 Measure your heart rate if desired.

See step 7 on page 16.

### 7 Turn on the fan if desired.

See step 8 on page 16.

### 8 When you are finished exercising, remove the key from the console.

See step 8 on page 17.

**CAUTION: Always remove iFIT Cards from the iFIT slot when you are not using them.**

## HOW TO OPERATE THE PERSONAL TELEVISION

**IMPORTANT:** Before operating the television, you must connect a 75 ohm CATV cable to the 75 ohm terminal on the treadmill, a VCR or DVD player to the audio/video input jack, or a personal audio/video player to the audio/video plug below the television on the console. See page 12 for instructions.

Follow the steps below to operate the television.

### **1** Insert the key into the console.

See HOW TO TURN ON THE POWER on page 15.

### **2** Press the Power button to turn on the television, and press the AV button to select a television source.

Press the Power button repeatedly until the word TUNER appears on the screen. Next, select a television source by pressing the AV button repeatedly. If you have connected a 75 ohm CATV cable or a VCR to the 75 ohm terminal on the treadmill, press the AV button until the word TUNER appears on the screen. If you have plugged a DVD player or a VCR into the three audio/video input jack, press the AV button until the words INPUT 1 appear. If you have connected a personal audio/video player to the audio/video plug below the television on the console, press the AV button until the word MP3 appears. Note: To turn off the television, press the Power button until the word CONSOLE appears.

### **3** Press the Channel buttons to select the desired channel.

Note: Complete this step only if you are using analog cable. Otherwise, change channels through an external source such as your cable box or your VCR.

When the television is turned on, the screen will show the last cable channel that was selected. To

select a different channel, press the Channel (CH.) buttons. The selected cable channel number will appear on the screen for a few seconds. Note: The television is equipped with a channel memorizing function that allows you to go directly from the current channel to the next channel saved in memory. Before channels can be selected in this way, they must be saved in the television's memory. See HOW TO USE THE INFORMATION MODE on page 24.

### **4** Press the Volume buttons to adjust the volume.

When either Volume (VOL.) button is pressed, the volume level indicator will appear on the screen for a few seconds.

To use earphones or headphones (not included), plug them into the headphone jack below the key on the console.

## HOW TO USE THE STEREO SOUND SYSTEM

To play music or audio books through the console's stereo speakers, you must connect your MP3 player, CD player, or personal audio/video player to the console. Locate the audio/video plug below the television on the console, and plug it into a jack on your MP3 player, CD player, or personal audio/video player. **Make sure that the audio/video cable is fully plugged in.**

Next, press the Play button on your MP3 player, CD player, or personal audio/video player. Then, adjust the volume on your MP3 player, CD player, or personal audio/video player. You can also adjust the volume on the console by pressing the Volume increase and decrease buttons.

If you are using a personal CD player or a DVD player and the CD or DVD skips, set the CD player or DVD player on the floor or another flat surface instead of on the console.



## HOW TO USE THE INFORMATION MODE

The console features an information mode that allows you to view treadmill usage information, select a system of measurement for the console, and turn on and turn off the demo mode. The information mode also allows you to adjust the settings of the television and to save channels into the television's memory.

Follow the steps below to use the information mode.

### **1** Hold down the Stop button while inserting the key into the console.

When the information mode is selected, the lower part of the screen will show the total number of miles or kilometers that the walking belt has moved (DISTANCE) and the total number of hours that the treadmill has been used (TIME).

In addition, the center of the screen will show the word ENGLISH, for miles, or the word METRIC, for kilometers. Press the Speed + button to change the unit of measurement if desired.

The words AUDIO TRAINER: ALL, AUDIO TRAINER: ON, or AUDIO TRAINER: OFF will also appear in the center of the screen. When you use an iFIT Card, the voice of a personal trainer will guide you through your workouts. When the AUDIO TRAINER: ALL setting is selected, the personal trainer will guide you through your workouts and instruct you how to purchase more iFIT Cards. When the AUDIO TRAINER: ON setting is selected, the personal trainer will simply guide you through your workouts. When the AUDIO TRAINER: OFF setting is selected, the voice of the personal trainer will not be heard. Press the Incline decrease button repeatedly to select the desired audio setting.

**IMPORTANT:** If the words DEMO ON appear in the center of the display, the demo mode is selected. This mode is intended to be used only when a treadmill is displayed in a store. When the demo mode is selected, the power cord can be plugged in, the key can be removed from the console, and the screen will automatically display a preset sequence of information. The buttons on the console will not function. **If the words DEMO ON appear when the information mode is selected, press the Speed – button so the words DEMO OFF appear.**

### **2** Press the Power button and adjust the brightness, contrast, color, sharpness, and/or hue of the television.

When the Power button is pressed, the brightness level indicator will appear on the television screen. Press the Volume buttons to adjust the brightness setting if desired.

Next, press the Channel buttons until the contrast, color, sharpness, or hue level indicator appears. Adjust the settings, if desired, by pressing the Volume buttons.

### **3** Press the Power button again and add or remove channels.

Note: Complete this step only if you are using analog cable.

After all valid cable channels available in your area have been saved into the television's memory (see step 5 on page 25), you can manually add channels or remove unwanted channels.

To add or remove a cable channel, first press the Channel buttons until the desired channel number appears on the screen. Then, press the Volume increase button to add the channel, or the Volume decrease button to remove the channel. Continue this process until you have added all desired channels and removed all unwanted channels.

### **4** Press the Power button again and select a cable connection if necessary.

If you have connected a CATV cable, one of the three Cable settings should be selected; try all three Cable settings, if necessary, to find the optimal setting. Press the Volume increase button to select the Standard Cable setting, the Channel decrease button to select the Cable IRC setting, or the Channel increase button to select the Cable HRC setting.



**5** Press the Power button again and save channels into the television's memory.

When the Power button is pressed, the television will begin scanning all the cable channels available in your area. When no cable signal is detected on a channel, the channel will be skipped. When a cable signal is detected, the channel will be saved into memory and the next channel will be selected. This process will continue until the highest channel is reached. **Do not remove the key while the television is scanning channels.** Note: If you are viewing channels through an external source such as a cable box or a VCR, the television will save only the channel used by the external source.

**6** When you are finished using the information mode, remove the key.

To exit the information mode at any time (except while the television is scanning channels), remove the key from the console.

**THE OPTIONAL CHEST PULSE SENSOR**

An optional chest pulse sensor offers hands-free operation as it monitors your heart rate during your workouts. **To purchase the optional chest pulse sensor, call the telephone number on the front cover of this manual.**

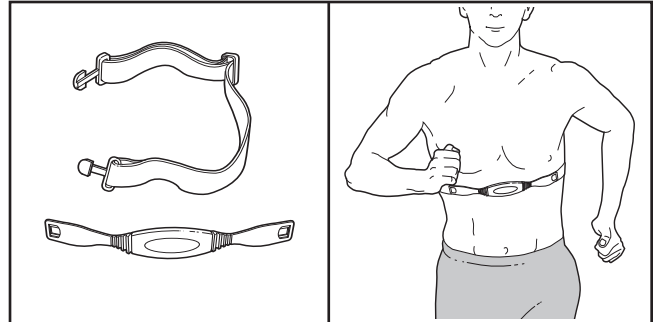

# HOW TO FOLD AND MOVE THE TREADMILL

## HOW TO FOLD THE TREADMILL FOR STORAGE

Before folding the treadmill, adjust the incline to the lowest position. If you do not do this, you may damage the treadmill. Remove the key and unplug the power cord. **CAUTION: You must be able to safely lift 45 pounds (20 kg) to raise, lower, or move the treadmill.**

1. Hold the treadmill frame with your hands in the location shown by the arrow at the right. **CAUTION: To decrease the possibility of injury, bend your legs and keep your back straight. As you raise the frame, make sure to lift with your legs rather than with your back.** Raise the frame about halfway to the vertical position.

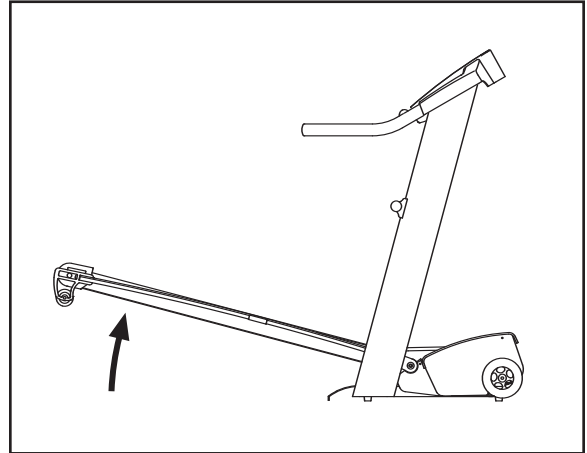

2. Move your right hand to the position shown and hold the treadmill firmly. Pull the latch knob to the left and hold it. Raise the frame until the plate passes the pin on the latch knob. Release the latch knob. **Make sure that the plate is resting against the pin as shown.**

**To protect the floor or carpet from damage, place a mat under the treadmill. Keep the treadmill out of direct sunlight. Do not leave the treadmill in the storage position in temperatures above 85° Fahrenheit.**

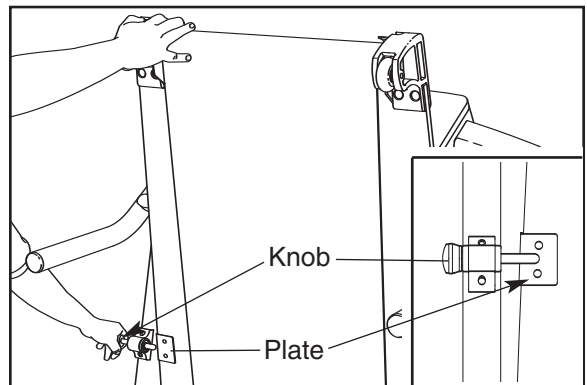

## HOW TO MOVE THE TREADMILL

Before moving the treadmill, convert the treadmill to the storage position as described above. **Make sure that the plate is securely held by the pin on the lock knob.**

1. Hold the handrails and place one foot against a wheel.
2. Tilt the treadmill back until it rolls freely on the wheels. Carefully move the treadmill to the desired location. **Never move the treadmill without tipping it back. To reduce the risk of injury, use extreme caution while moving the treadmill. Do not attempt to move the treadmill over an uneven surface.**
3. Place one foot against a wheel, and carefully lower the treadmill until it is resting in the storage position.

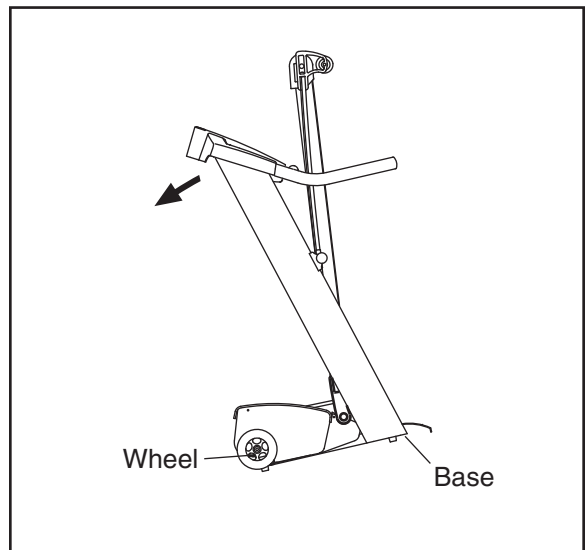

## HOW TO LOWER THE TREADMILL FOR USE

1. Hold the upper end of the treadmill with your right hand as shown. Using your left hand, pull the latch knob to the left and hold it. Pivot the frame down until the walking platform is past the pin on the latch knob.

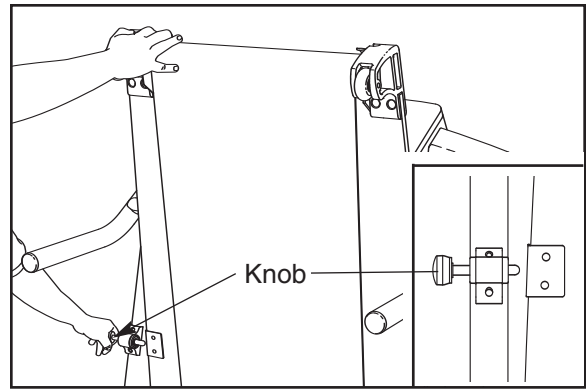

2. Hold the frame firmly with both hands, and lower it to the floor. **To decrease the possibility of injury, bend your legs and keep your back straight.**

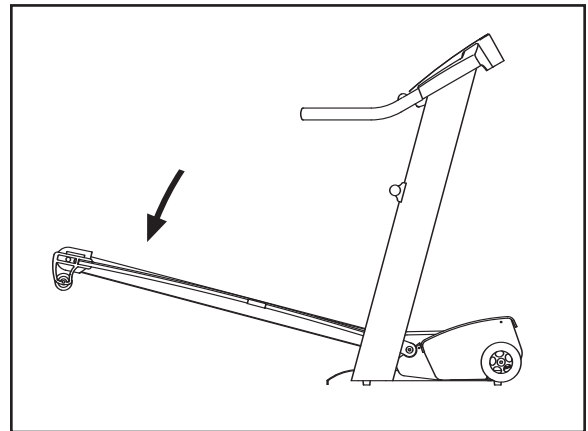

# TROUBLESHOOTING

Most treadmill problems can be solved by following the steps below. Find the symptom that applies, and follow the steps listed. If further assistance is needed, please see the front cover of this manual.

## PROBLEM: The power does not turn on

**SOLUTION:** a. Make sure that the power cord is plugged into a surge suppressor, and that the surge suppressor is plugged into a properly grounded outlet (see page 13). Use only a single-outlet surge suppressor that meets all of the specifications described on page 13. Important: The treadmill is not compatible with GFCI-equipped outlets.

b. After the power cord has been plugged in, make sure that the key is inserted into the console.

c. Check the reset/off circuit breaker located on the treadmill frame near the power cord. If the switch protrudes as shown, the circuit breaker has tripped. To reset the circuit breaker, wait for five minutes and then press the switch to the reset position.

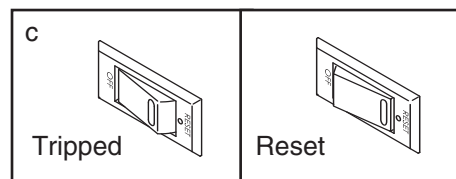

## PROBLEM: The power turns off during use

**SOLUTION:** a. Check the reset/off circuit breaker (see the drawing above). If the circuit breaker has tripped, wait for five minutes and then press the switch to the reset position.

b. Make sure that the power cord is plugged in. If the power cord is plugged in, unplug it, wait for five minutes, and then plug it back in.

c. Remove the key from the console. Reinsert the key into the console.

d. If the treadmill still will not run, please see the front cover of this manual.

## PROBLEM: The displays of the console do not function properly

**SOLUTION:** a. Remove the key from the console and **unplug the power cord**. Carefully tip the treadmill down as shown in drawing a. Remove the Screws (87) from the Motor Hood (33). Raise the Uprights (20) and carefully remove the Motor Hood.

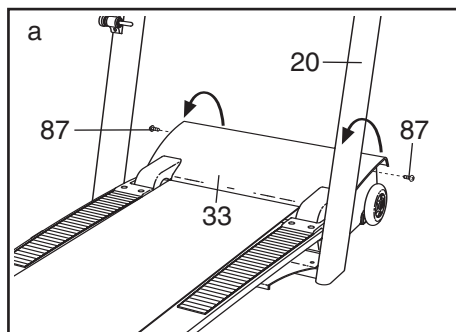

Locate the Reed Switch (22) and the Magnet (18) on the left side of the Pulley (17). Turn the Pulley until the Magnet is aligned with the Reed Switch. **Make sure that the gap between the Magnet and the Reed Switch is about 1/8"**. If necessary, loosen the Screw (13), move the Reed Switch slightly, and then retighten the Screw. Reattach the Hood (not shown) with the Screws (not shown). Run the treadmill for a few minutes to check for a correct speed reading

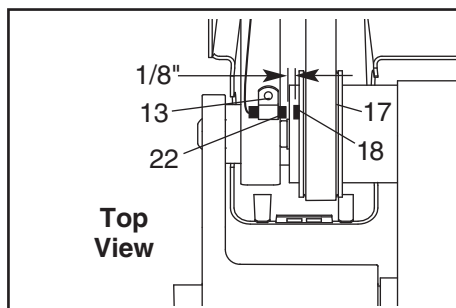

**PROBLEM: The walking belt slows when walked on**

**SOLUTION:** a. Use only a single-outlet surge suppressor that meets all of the specifications described on page 13.

b. If the walking belt is overtightened, treadmill performance may decrease and the walking belt may become damaged. Remove the key and **UNPLUG THE POWER CORD**. Using the hex key, turn both rear roller adjustment bolts counterclockwise, 1/4 of a turn. When the walking belt is properly tightened, you should be able to lift each side of the walking belt 3 to 4 inches off the walking platform. Be careful to keep the walking belt centered. Plug in the power cord, insert the key, and run the treadmill for a few minutes. Repeat until the walking belt is properly tightened.

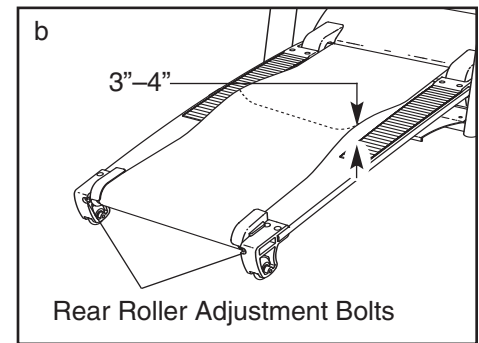

c. If the walking belt still slows when walked on, see the front cover of this manual.

**PROBLEM: The walking belt is off-center or slips when walked on**

**SOLUTION:** a. If the walking belt is off-center, remove the key and **UNPLUG THE POWER CORD**. **If the walking belt has shifted to the left**, use the hex key to turn the left rear roller bolt clockwise 1/2 of a turn; **if the walking belt has shifted to the right**, turn the left rear roller bolt counterclockwise 1/2 of a turn. Be careful not to overtighten the walking belt. Plug in the power cord, insert the key, and run the treadmill for a few minutes. Repeat until the walking belt is centered.

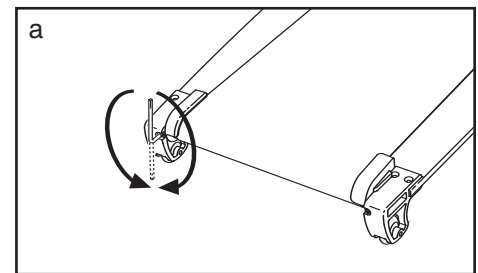

b. If the walking belt slips when walked on, first remove the key and **UNPLUG THE POWER CORD**. Using the hex key, turn both rear roller bolts clockwise, 1/4 of a turn. When the walking belt is correctly tightened, you should be able to lift each side of the walking belt 3 to 4 inches off the walking platform. Be careful to keep the walking belt centered. Plug in the power cord, insert the key, and carefully walk on the treadmill for a few minutes. Repeat until the walking belt is properly tightened.

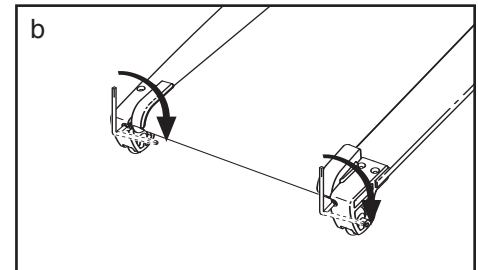

**PROBLEM: The incline of the treadmill does not change correctly**

**SOLUTION:** a. With the key in the console, press one of the Incline buttons. **While the incline is changing, remove the key.** After a few seconds, re-insert the key. The treadmill will automatically rise to the maximum incline level and then return to the minimum level. This will recalibrate the incline system.

**PROBLEM: Television reception is poor**

**SOLUTION:** a. Check for the problems listed below and follow the applicable instructions.

- Ignition (black spots or horizontal streaks that appear on a picture that flutters or drifts)—Usually this is caused by interference from automobile ignition systems, neon lamps, electric drifts, or other electric appliances. Try changing the position of other electric appliances to correct the problem. Make sure that the treadmill is plugged into its own electrical circuit.
- Ghosts—Ghosts are caused by the television signal following two paths—one is the direct path and the other is reflected from tall buildings, hills, or other objects.
- Blue Screen—If the cable channel signal is weak, the picture may be of poor quality or a blue screen may appear.

Note: If one of these symptoms appears, the symptom may be caused by the local cable company signal reception.

**PROBLEM: While using an iFIT Card, you cannot hear the voice of the personal trainer**

**SOLUTION:** a. If you cannot hear the personal trainer's voice while using a program on an iFIT Card, the AUDIO TRAINER: OFF setting is selected. See step 1 on page 24 and select the AUDIO TRAINER: ALL or AUDIO TRAINER: ON setting.

# CONDITIONING GUIDELINES

**⚠️ WARNING:** Before beginning this or any exercise program, consult your physician. This is especially important for individuals over the age of 35 or individuals with pre-existing health problems.

The pulse sensor is not a medical device. Various factors, including your movement, may affect the accuracy of heart rate readings. The sensor is intended only as an exercise aid in determining heart rate trends in general.

The following guidelines will help you to plan your exercise program. For more detailed exercise information, obtain a reputable book or consult your physician.

## EXERCISE INTENSITY

Whether your goal is to burn fat or to strengthen your cardiovascular system, the key to achieving the desired results is to exercise with the proper intensity. The proper intensity level can be found by using your heart rate as a guide. The chart below shows recommended heart rates for fat burning and aerobic exercise.

165	155	145	140	130	125	115	❤️
145	138	130	125	118	110	103	❤️
125	120	115	110	105	95	90	❤️
20	30	40	50	60	70	80	

To find the proper heart rate for you, first find your age near the bottom of the chart (ages are rounded off to the nearest ten years). Next, find the three numbers above your age. The three numbers define your “training zone.” The lower two numbers are recommended heart rates for fat burning; the higher number is the recommended heart rate for aerobic exercise.

To measure your heart rate during exercise, use the pulse sensor on the console.

## Fat Burning

To burn fat effectively, you must exercise at a relatively low intensity level for a sustained period of time. During the first few minutes of exercise, your body

uses easily accessible *carbohydrate calories* for energy. Only after the first few minutes does your body begin to use stored *fat calories* for energy. If your goal is to burn fat, adjust the speed and incline of the treadmill until your heart rate is near the lowest number in your training zone.

For maximum fat burning, adjust the speed and incline of the treadmill until your heart rate is near the middle number in your training zone.

## Aerobic Exercise

If your goal is to strengthen your cardiovascular system, your exercise must be “aerobic.” Aerobic exercise is activity that requires large amounts of oxygen for prolonged periods of time. This increases the demand on the heart to pump blood to the muscles, and on the lungs to oxygenate the blood. For aerobic exercise, adjust the speed and incline of the treadmill until your heart rate is near the highest number in your training zone.

## WORKOUT GUIDELINES

Each workout should include the following three parts:

**A Warm-up**—Start each workout with 5 to 10 minutes of stretching and light exercise. A proper warm-up increases your body temperature, heart rate and circulation in preparation for exercise.

**Training Zone Exercise**—After warming up, increase the intensity of your exercise until your pulse is in your training zone for 20 to 60 minutes. (During the first few weeks of your exercise program, do not keep your pulse in your training zone for longer than 20 minutes.) Breathe regularly and deeply as you exercise—never hold your breath.

**A Cool-down**—Finish each workout with 5 to 10 minutes of stretching to cool down. This will increase the flexibility of your muscles and will help prevent post-exercise problems.

## EXERCISE FREQUENCY

To maintain or improve your condition, complete three workouts each week, with at least one day of rest between workouts. After a few months, you may complete up to five workouts each week if desired. The key to success is to make exercise a regular and enjoyable part of your everyday life.

## SUGGESTED STRETCHES

The correct form for several basic stretches is shown at the right. Move slowly as you stretch—never bounce.

### 1. Toe Touch Stretch

Stand with your knees bent slightly and slowly bend forward from your hips. Allow your back and shoulders to relax as you reach down toward your toes as far as possible. Hold for 15 counts, then relax. Repeat 3 times. Stretches: Hamstrings, back of knees and back.

### 2. Hamstring Stretch

Sit with one leg extended. Bring the sole of the opposite foot toward you and rest it against the inner thigh of your extended leg. Reach toward your toes as far as possible. Hold for 15 counts, then relax. Repeat 3 times for each leg. Stretches: Hamstrings, lower back and groin.

### 3. Calf/Achilles Stretch

With one leg in front of the other, reach forward and place your hands against a wall. Keep your back leg straight and your back foot flat on the floor. Bend your front leg, lean forward and move your hips toward the wall. Hold for 15 counts, then relax. Repeat 3 times for each leg. To cause further stretching of the achilles tendons, bend your back leg as well. Stretches: Calves, achilles tendons and ankles.

### 4. Quadriceps Stretch

With one hand against a wall for balance, reach back and grasp one foot with your other hand. Bring your heel as close to your buttocks as possible. Hold for 15 counts, then relax. Repeat 3 times for each leg. Stretches: Quadriceps and hip muscles.

### 5. Inner Thigh Stretch

Sit with the soles of your feet together and your knees outward. Pull your feet toward your groin area as far as possible. Hold for 15 counts, then relax. Repeat 3 times. Stretches: Quadriceps and hip muscles.

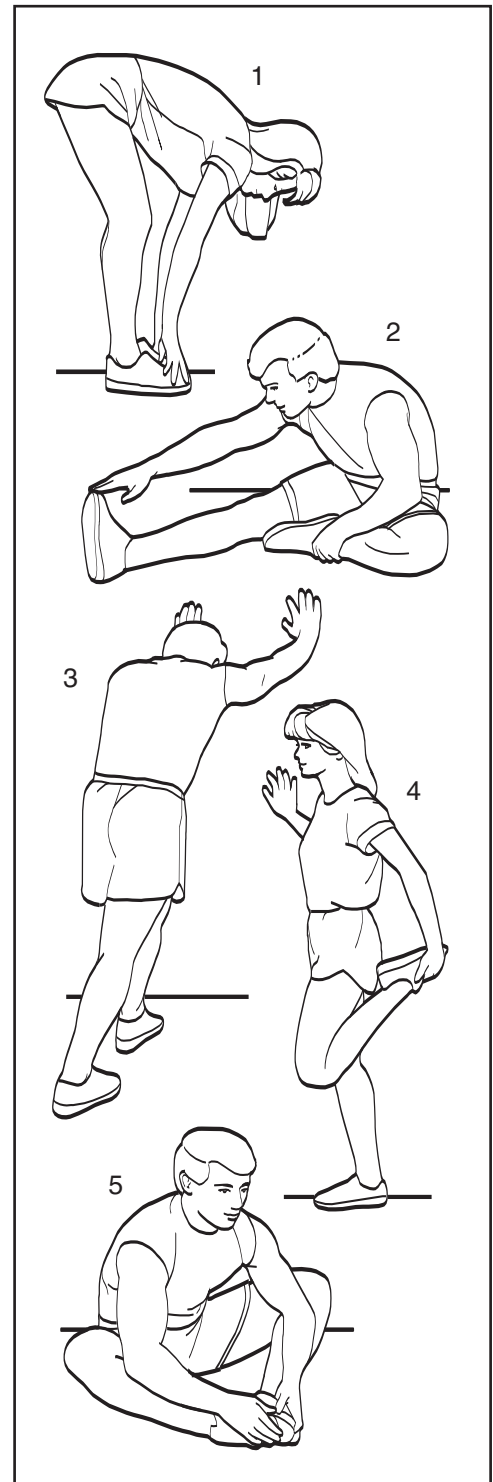



# NOTES

---

# PART LIST—Model No. NTL22907.1

R1107A

To locate the parts listed below, see the EXPLODED DRAWING starting on page 36.

Key No.	Qty.	Description	Key No.	Qty.	Description
1	2	Frame Thrust Washer	52	10	Plastic Tie
2	8	Endcap Bolt	53	4	Support Bracket Screw
3	1	Front Left Endcap	54	1	Incline Stop Bracket
4	2	Frame Pivot Washer	55	1	Incline Motor Bolt, Upper
5	8	Endcap Washer	56	1	Drive Roller Ground Wire
6	1	Latch Warning Decal	57	1	Idler Arm Spring
7	28	Screw	58	1	Idler Arm
8	1	Latch Plate	59	2	Rear Wheel
9	8	Endcap Nut	60	2	Rear Roller Star Washer
10	1	Front Right Endcap	61	2	Spring Washer
11	2	Endcap Spring	62	2	Rear Roller Bolt
12	2	Belt Guide	63	1	Lift Frame
13	1	Reed Switch Screw	64	1	Rear Roller
14	2	Frame Pivot Bolt	65	1	Foot Pad (Right)
15	1	Walking Platform	66	2	Handrail Endcap
16	1	Walking Belt	67	4	Star Washer
17	1	Front Roller	68	1	Handrail
18	1	Magnet	69	2	Latch Plate Screw
19	2	Frame Spacer	70	3	Cage Nut
20	1	Uprights	71	1	Hex Key
21	1	Reed Switch Clip	72	4	Handrail Bolt
22	1	Reed Switch	73	1	Upright Wire Harness
23	11	1/2" Screw	74	1	Base Plate Edging
24	5	Wire Clamp	75	1	Base Plate
25	1	Drive Motor	76	1	Latch Assembly
26	5	Hood Mount	77	3	Base Plate Bolt
27	2	Bolt	78	1	Electronics Bracket
28	1	Left Rear Endcap	79	1	Idler Arm Bushing
29	1	Left Roller Guard	80	1	Idler Arm Bolt
30	2	Hood Mount (Side)	81	4	Base Pad
31	2	Motor Bolt	82	4	1" Tek Screw
32	7	Nut	83	1	Filter Wire
33	1	Motor Hood	84	1	Idler Pulley Bolt
34	1	Latch Housing	85	2	Belly Pan Screw
35	1	Right Roller Guard	86	1	Drive Belt
36	1	Right Rear Endcap	87	13	Screw
37	1	Support Bracket Screw	88	4	Wheel Washer
38	1	Front Roller Adjustment Bolt	89	2	Front Wheel
39	1	Front Roller Nut	90	1	Upright Ground Wire
40	1	Incline Motor	91	2	Idler Arm Washer
41	1	Incline Motor Bolt, Lower	92	1	Electronics Bracket Star Washer
42	1	Transformer	93	1	iFIT Card Kit
43	1	Controller	94	2	Wheel Spacer
44	1	Foot Pad (Left)	95	1	Access Door
45	1	Belly Pan	96	2	Wheel Bushing
46	1	Power Cord Grommet	97	1	Idler Pulley
47	1	Power Cord	98	1	Console Base
48	1	Off/Reset Circuit Breaker	99	2	Hood Clip
49	1	Support Bracket	100	1	Fan
50	3	Tie Holder	101	1	Belly Pan Grommet
51	2	A/V Wire Screw	102	1	Hole Cap

Key No.	Qty.	Description
103	1	Key/Clip
104	2	Front Wheel Bolt
105	1	Console
106	1	Support Bracket
107	4	Fan Screw
108	1	TV Cable
109	2	TV Cable Nut
110	1	TV Cable Washer
111	2	Static Decal

Key No.	Qty.	Description
112	1	A/V Wire
*	—	4" Black Wire, M/F
*	—	6" Blue Wire, 2F
*	—	4" Red Wire, M/F
*	—	User's Manual

\*These parts are not illustrated.  
Specifications are subject to change without notice.

---

## ORDERING REPLACEMENT PARTS

To order replacement parts, please see the front cover of this manual. When ordering parts, be prepared to provide the following information:

- the MODEL NUMBER OF THE PRODUCT (NTL22907.1)
- the NAME OF THE PRODUCT (NordicTrack VIEWPOINT 8500 treadmill)
- the SERIAL NUMBER OF THE PRODUCT (see the front cover of this manual)
- the KEY NUMBER AND DESCRIPTION OF THE PART(S) (see the PART LIST starting on page 34 and the EXPLODED DRAWING starting on page 36)

# EXPLODED DRAWING A—Model No. NTL22907.1

R1107A

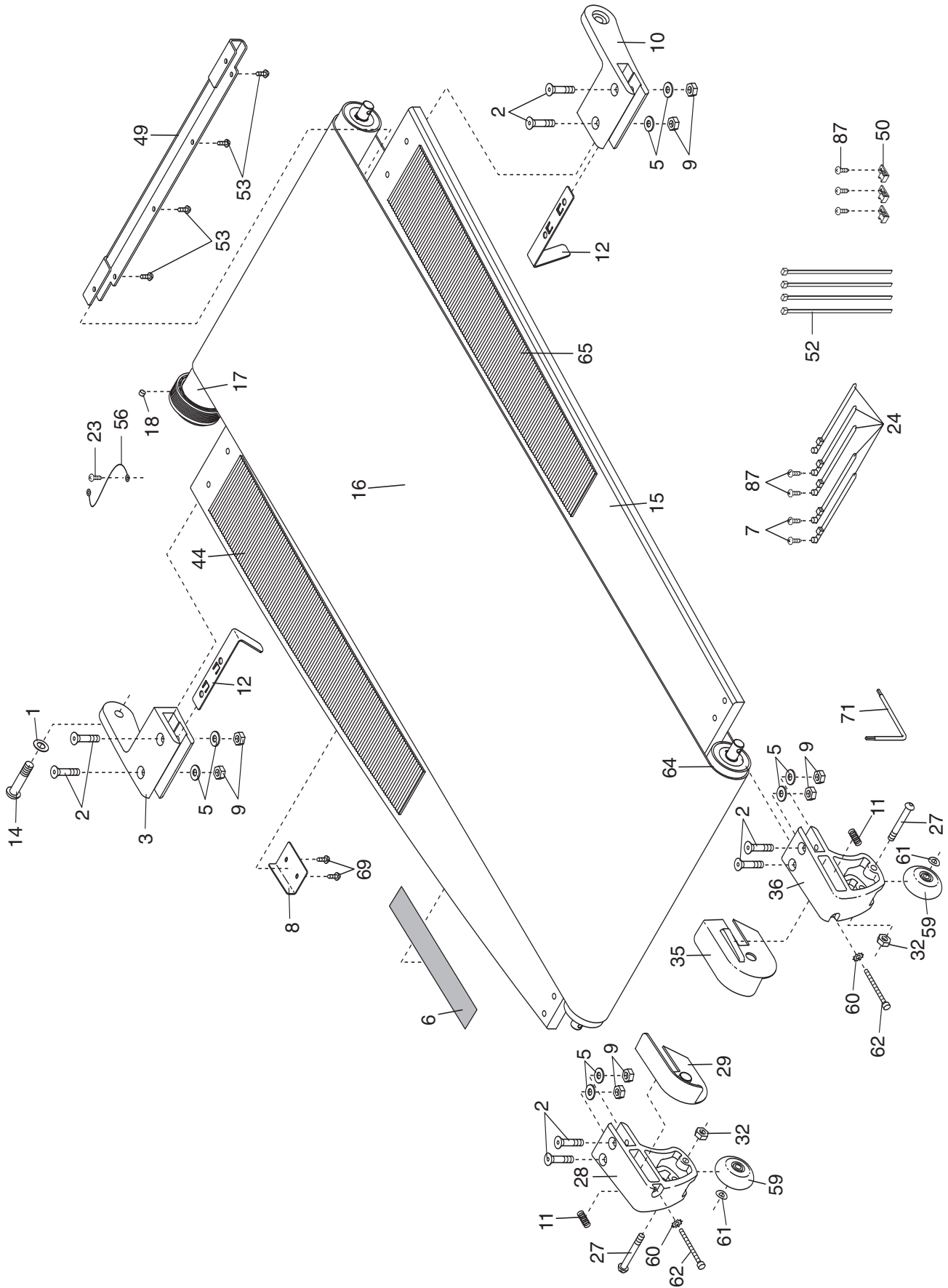



# EXPLODED DRAWING C—Model No. NTL22907.1

R1107A

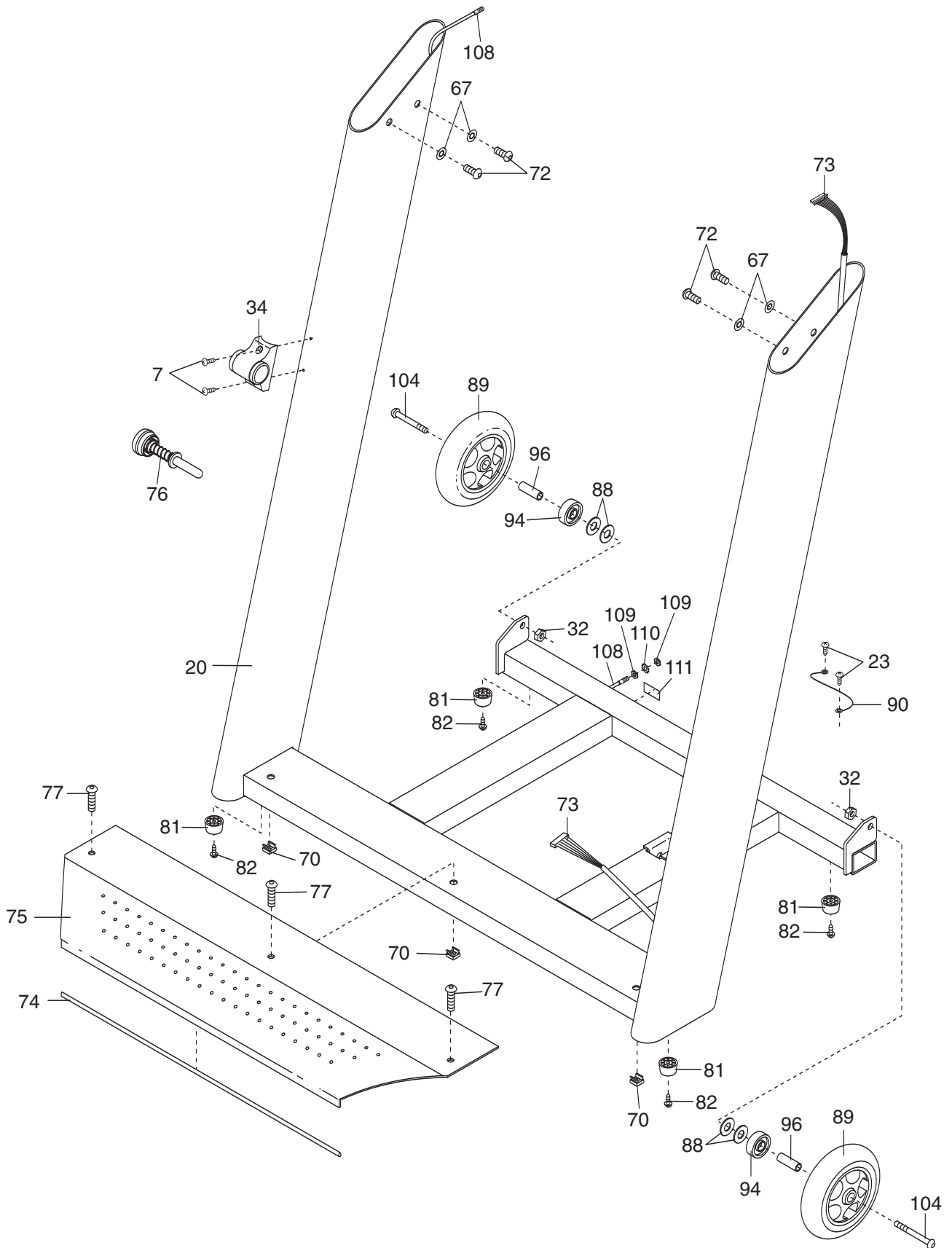

# EXPLODED DRAWING D—Model No. NTL22907.1

R1107A

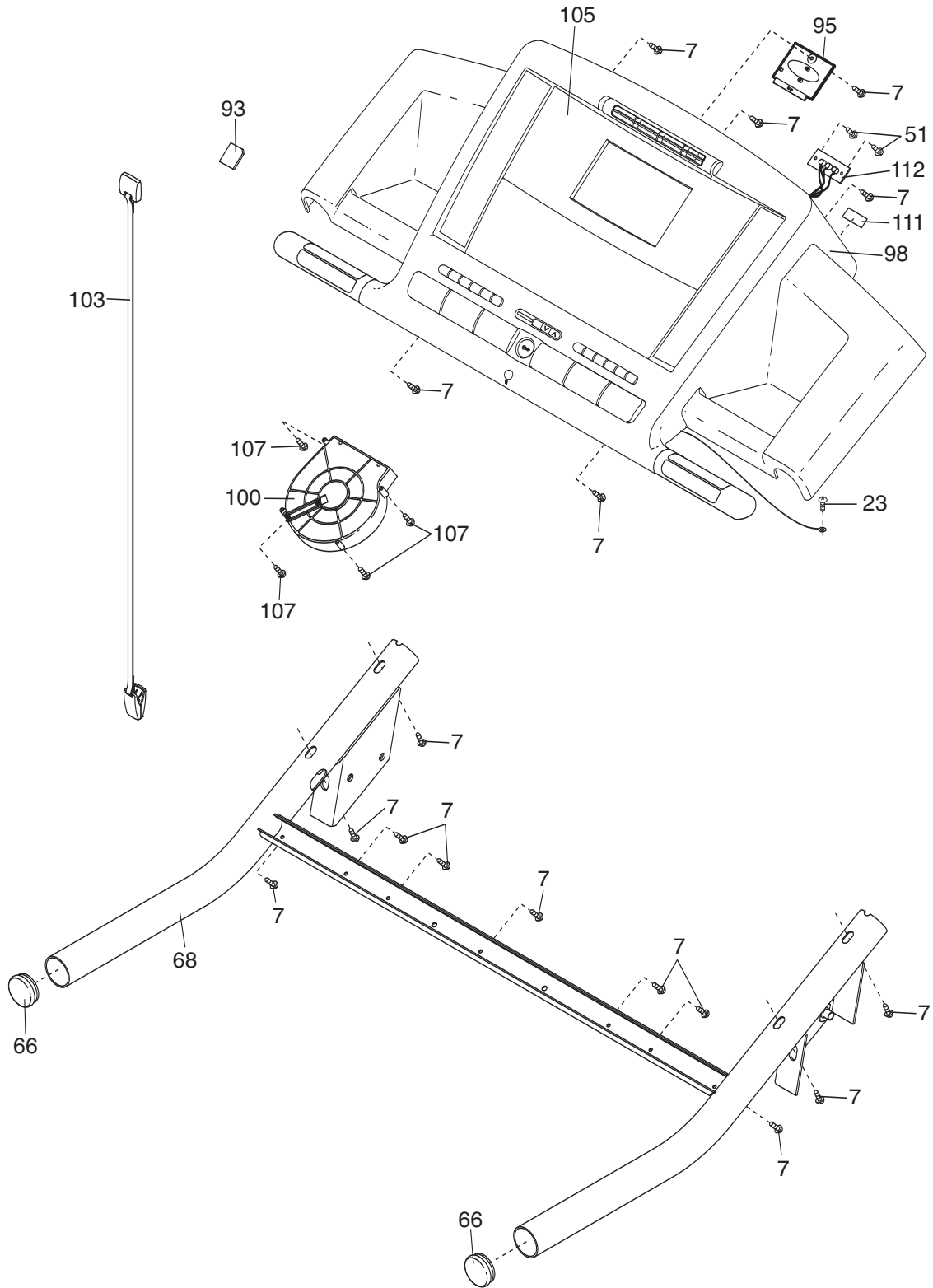

## LIMITED WARRANTY

**WHAT IS COVERED**—The entire NordicTrack VIEWPOINT 8500 treadmill (“Product”) is warranted to be free of all defects in material and workmanship.

**WHO IS COVERED**—The original purchaser or any person receiving the Product as a gift from the original purchaser.

**HOW LONG IS IT COVERED**—ICON Health & Fitness, Inc. (“ICON”), warrants the drive motor for life. Parts and labor are warranted for one year from the date of purchase.

**WHAT WE DO TO CORRECT COVERED DEFECTS**—We will ship to you, without charge, any replacement part or component, providing the repairs are authorized by ICON first and are performed by an ICON trained and authorized service provider, or, at our option, we will replace the Product.

**WHAT IS NOT COVERED**—Any failures or damage caused by unauthorized service, misuse, accident, negligence, improper assembly or installation, alterations, modifications without our written authorization or by failure on your part to use, operate, and maintain as set out in your User’s Manual (“Manual”). This warranty does not extend to products used for commercial or rental purposes.

**WHAT YOU MUST DO**—Always retain proof of purchase, such as your bill of sale; store, operate, and maintain the Product as specified in the Manual; notify our Customer Service Department of any defect within 10 days after discovery of the defect; as instructed, return any defected part for replacement or, if necessary, the entire product, for repair.

**USER’S MANUAL**—It is VERY IMPORTANT THAT YOU READ THE MANUAL before operating the Product. Remember to do the periodic maintenance requirements specified in the Manual to assure proper operation and your continued satisfaction.

**HOW TO GET PARTS AND SERVICE**—Simply call our Customer Service Department at 1-888-825-2588 and tell them your name and address and the serial number of your Product. They will tell you how to get a part replaced, or if necessary, arrange for service where your Product is located or advise you how to ship the Product for service. Before shipping, always obtain a Return Authorization Number (RA No.) from our Customer Service Department; securely pack your Product (save the original shipping carton if possible); put the RA No. on the outside of the carton and insure the product. Include a letter explaining the product or problem and a copy of your proof of purchase if you believe the service is covered by warranty.

ICON is not responsible or liable for indirect, special or consequential damages arising out of or in connection with the use or performance of the product or damages with respect to any economic loss, loss of property, loss of revenues or profits, loss of enjoyment or use, costs of removal, installation or other consequential damages of whatsoever nature. Some states do not allow the exclusion or limitation of incidental or consequential damages. Accordingly, the above limitation may not apply to you.

The warranty extended hereunder is in lieu of any and all other warranties and any implied warranties of merchantability or fitness for a particular purpose is limited in its scope and duration to the terms set forth herein. Some states do not allow limitations on how long an implied warranty lasts. Accordingly, the above limitation may not apply to you.

No one is authorized to change, modify or extend the terms of this limited warranty.

This warranty gives you specific legal rights and you may have other rights which vary from state to state.

**ICON HEALTH & FITNESS, INC., 1500 S. 1000 W., LOGAN, UT 84321-9813**