

LifeSpan™



TR2250-HR
TR2250-HRC

Owners Manual
Version 1.1

table of contents

	Page
Introduction1
Specifications2
Limited Home Use Warranty3
Important Safety Precautions4
Getting Fit5
Assembly Instructions7
Electronics Overview10
Exercise Programs11
Treadmill Operations13
Moving and Storage16
Trouble Shooting17
Maintenance and Cleaning18

Congratulations on the purchase of your LifeSpan treadmill.

We all know that exercise is a key component to achieving the level of Health and Wellness that all of us desire. Regular activity prevents the development of numerous diseases, helps to reduce stress, leads to an improved self image, weight loss and increased energy levels.

The LifeSpan product line is designed specifically for people who want to make exercise a part of their lifestyles. Your treadmill includes the features you want to make your exercise routine enjoyable and effective. These features include preset programs that you can tailor for your specific requirements and display readouts to monitor the intensity and duration of your workout.

To complement these features we have designed and manufactured your treadmill to the highest quality standards. The all steel frame construction, heavy duty deck, pre-lubricated belt, and 2.25 horse power continuous duty motor are all included to provide years of use and require minimal ongoing maintenance.

Please read this manual thoroughly before assembly and operation of your LifeSpan treadmill. It includes basic information on starting an exercise program, and safety tips that will assist you in reaching your goals for a healthy lifestyle.

To keep your treadmill in optimal condition, please pay attention to the maintenance and cleaning section of this manual and remember that some kinds of service should only be performed by a qualified service technician. If service is required, please contact your authorized PCE Health and Fitness Retailer. If a question or problem arises that cannot be answered by your retailer, contact us:

PCE Health and Fitness
PO Box 981316
Park City, Utah 84098 -1316
Phone: (435) 940 -1180
Fax: (435) 649 -3141
www.pcefitness.com

Neither PCE Health and Fitness nor its representatives can accept responsibility for any damage or injury incurred as a result of information presented in the manual except under the terms of the product warranty.

specifications

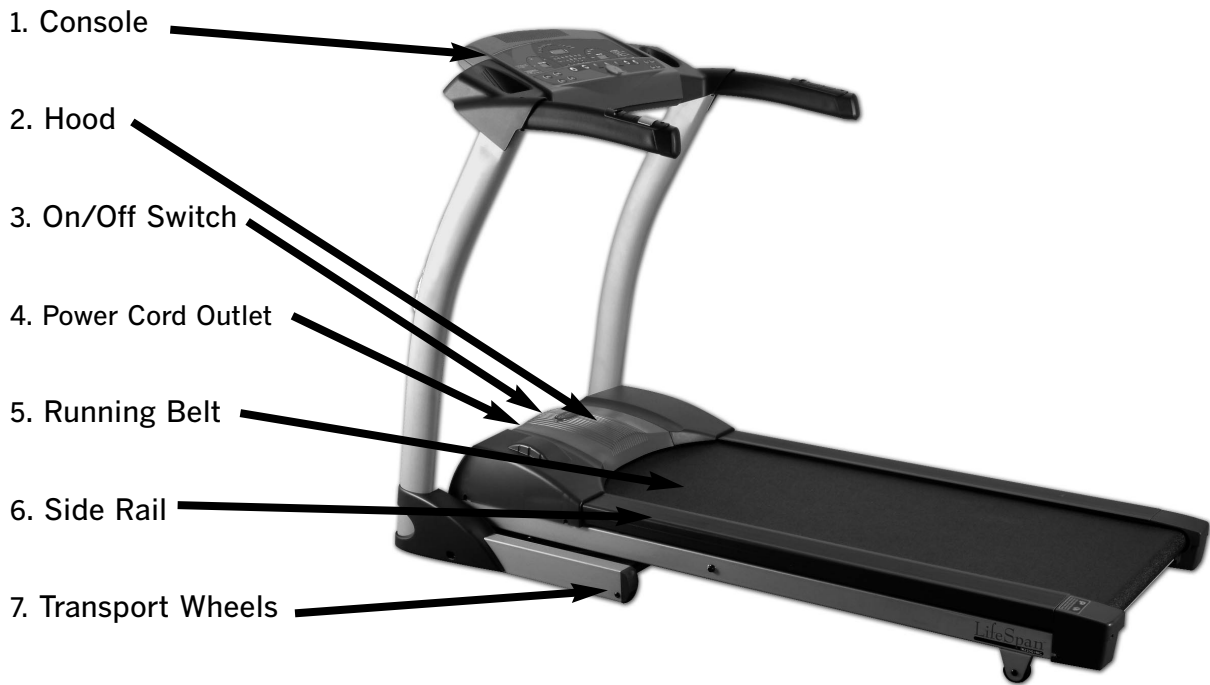

Dimensions

76" L * 34.5" W * 53" H

Weight	190 Pounds
Construction	All Steel Welded Frame
Power Requirements	120 Volts nominal (grounded outlet required) 10 Amps
Motor	TR2250-HR: 2 HP / TR2250-HRC: 2.25 HP
Display Type	3 LED Windows
Data Displayed	Time, Distance, Calories, Incline, Speed, Heart Rate, Lap Count
Programmed Courses	6 Speed, 6 Incline, 2 User, 1 Target Heart Rate, 1 Body Fat
Speed Range	.6 - 11 MPH
Incline Range	0% - 15%

limited home use warranty

The LifeSpan TR2250 comes with the following limited warranty, which applies only to the use of this treadmill in the home, for residential, non-commercial purposes:

- Frame: Lifetime
- Motor: Lifetime
- Parts: 2 years
- Labor: 1 year

PCE Health and Fitness warrants that the equipment it manufactures is free from defects in material and workmanship under normal use and service. The periods above are based on the date of purchase. During these periods, PCE Health and Fitness will repair or replace any defective part. Free labor is included for the first year.

If within the time frames specified above, any part of the LifeSpan fails to operate properly contact your authorized PCE Health and Fitness retailer to report the problem. All labor shall be supplied by the authorized retailer that sold your product and the product must be located within that retailer's service area. If you are unable to reach the dealer that you purchased the product from, contact PCE Health and Fitness at our web site, www.pcefitness.com or at (435) 940-1180.

PCE Health and Fitness reserves the right to make changes and improvements in our products without incurring any obligations to similarly alter any product purchased. In order to insure our product warranty and to ensure the safe and efficient operation of your treadmill, only authorized parts can be used. The warranty is void if any parts other than those provided by PCE Health and Fitness are used.

Exclusions and Limitations

- This warranty does not apply to any defects caused by negligence, misuse, improper assembly or maintenance, accident, or an "act of god".
- This warranty does not apply to discoloration of paint or plastics
- PCE Health and Fitness shall not be responsible for incidental or consequential damages.
- This warranty is nontransferable from the original owner.

Registration

You must register your LifeSpan product before a warranty claim can be processed. To complete your registration card online, go to www.pcefitness.com and fill out the registration card online or fill out the warranty card provided with your treadmill and mail it today. Registration Cards must be completed and sent to PCE Fitness within 30 days of purchase to activate the Product Warranty on your LifeSpan equipment. Product Warranties are not valid unless properly completed and sent to PCE Fitness within this 30 day period.

Note: Read ALL instructions before using your LifeSpan treadmill.

important safety precautions

When using electrical equipment, basic precautions should always be followed, including:

- Never drop or insert any object into any opening.
- Never operate this treadmill if it has been damaged, if it is not working properly or if it has been exposed to water. Return the treadmill to a retailer for examination and repair.
- To reduce the risk of electric shock, unplug the treadmill from the wall outlet when not in use, before performing any maintenance, or before moving the treadmill.
- Do not use outdoors.
- Do not lean against or climb on the treadmill. Doing so may result in the treadmill tipping and falling and could result in serious personal injury.
- Do not hang or place items on the treadmill. Doing so could result in shifting the weight balance of the treadmill causing it to tip over or fall causing serious personal injury.
- Do not operate the treadmill with the side rails or dust covers removed.
- Keep the treadmill on a solid surface, with the sides and front a minimum of two feet from any walls and furniture. Make sure that the area behind the treadmill remains completely clear during use. A minimum of 4 feet of clearance behind the treadmill is required for safety reasons.
- Do not operate where aerosol spray products are being used or where oxygen is being administered.
- Never place the power cord under carpeting or place any object on top of the cord, which may pinch or damage it.
- Use this exercise product for its intended use as described in this Owners Manual. Do not use attachments that are not recommended by PCE Health and Fitness
- Do not leave your treadmill running while not in use.

Children and Pets

- Keep children off your treadmill at all times.
- When in use, young children and pets should be kept at least 10 feet away.

Grounding Instructions

- Never use extension cords between the treadmill and the wall outlet.
- This product is for use on a nominal 120 volt circuit, and has a grounding plug similar to the illustration below. Never remove or otherwise bypass with an adapter the electrical ground that is included.

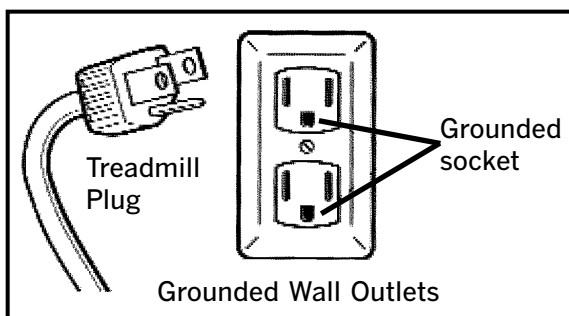

Danger: Improper connection of the equipment grounding conductor can result in the risk of electric shock. Check with a qualified electrician or service person if you are in doubt as to whether the product is properly grounded. Do not modify the plug provided with the product. If it will not fit in the outlet, have the proper outlet installed by a qualified electrician.

Other Safety Tips

- Always consult a physician before beginning this or any exercise program.
- If you experience chest pains, nausea, dizziness or shortness of breath, stop exercising immediately and consult your physician before continuing.
- Do not wear clothing or jewelry that might catch on any part of the treadmill.
- This treadmill is equipped with a safety key. If the key is removed from the display, the treadmill will immediately stop. Always clip the cord that is attached to the safety key to a part of your clothing so the key will be pulled from the display, stopping the treadmill, in case of an emergency.

Save These Instructions

Cardiovascular endurance is the most important component of physical fitness. There are two types of cardiovascular training, these are interval training and steady state training.

Interval training varies the amount of effort required to workout. The LifeSpan TR2250 comes with 6 programs that vary incline automatically and 6 programs that vary speed. All of these programs vary the amount of effort required during the workout either through automatically adjusting the incline or the speed.

Steady state training keeps the workload constant. The Manual program on your LifeSpan treadmill allows you to manually control the speed and incline of your treadmill providing you with a constant workout that you completely control. The TR2250 models also support Heart Rate training where you can preset the treadmill to a target heart rate. On the TR2250-HR the treadmill will need to pick up your heart rate through the grip pulse sensors located on the handlebars, while the TR2250-HRC has a built in receiver that picks up your heart rate while using a heart rate chest strap. The treadmill will then automatically adjust the speed to maintain your target heart rate.

If you have a requirement to maintain a steady heart rate during your workout, the manual or Target Heart Rate Program is the best selection.

Regardless of your personal fitness goals and the program that you pursue, warming up and cooling down before and after you workout will help reduce the risk of injury and improve the effectiveness of your workout.

Warming up is important to bring your body from its normal level of activity to a state where it is ready to exercise by increasing the flow of blood to the muscle to raise the muscle temperature. This will increase the muscle elasticity and protect the joints. The warm up period also helps to mentally prepare you for your workout.

Warmups should be done at a low intensity level and last for at least five minutes.

Cooling down after your workout is required to gradually bring your cardiovascular system down to its normal level.

Follow your workout with at least 10 minutes of stretching. Focus on the major muscle groups of the lower extremity. When stretching, stretch the muscle until you feel gentle tension, hold it and wait for the tension to relax while the muscle elongates, stretch the muscle again until you feel gentle tension.

Do not bounce when you stretch, bouncing is not an effective approach to stretching and can lead to injury.

The three components of a successful cardiovascular exercise program are:

- Frequency
- Intensity
- Time

In terms of **frequency**, you should try and exercise at least three times per week and no more than five times per week. Preferably you should try to exercise every other day to give your body a days rest in-between workouts.

The **intensity** of each workout refers to how hard you feel your working and can be measured by your heart rate. Depending on your fitness goals, exercise between 55% and 90% of your maximum heart rate. A simple way of estimating your maximum heart rate is by subtracting your age from 220. As a general rule of thumb, if your fitness objective is to lose weight, you will want to keep your heart rate at between 60% and 75% of your maximum heart rate. If your objective is improved aerobic performance keep your heart rate between 75% and 85% of your maximum heart rate.

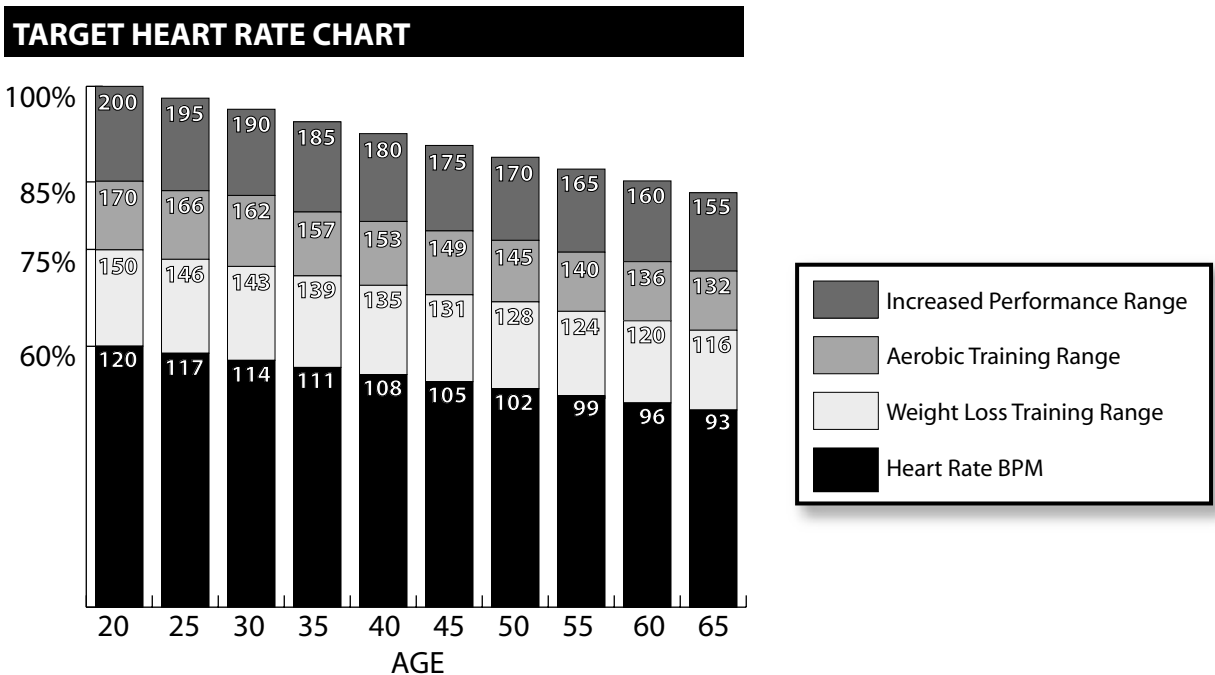

To achieve benefits from your workout, your workout **time** should be at least 20 minutes per session. If you are trying to lose weight focus on longer (more than 30 minutes) less intense workouts, to improve your aerobic performance focus on shorter more intense workouts.

As a rule of thumb when your exercising, if your having trouble completing a sentence, you are working too hard. When exercising, you should be able to speak freely without gasping for air.

assembly instructions

Since your treadmill is a heavy piece of equipment, we recommend that after taking off the top portion of the box, you slit the corners of the lower carton and fold down the sides. This will eliminate the need for you to pick up the treadmill over the sides of the box.

Prior to starting the assembly process take all of the parts out of the box, remove all plastic bags, and lay them out on the floor to become familiar with the components. Make sure that you remove all parts packaged underneath the treadmill. You may need to slightly pick up the back of the treadmill to get better access to the parts on the bottom. You will notice that the treadmill is completely assembled except for the handlebars and the display.

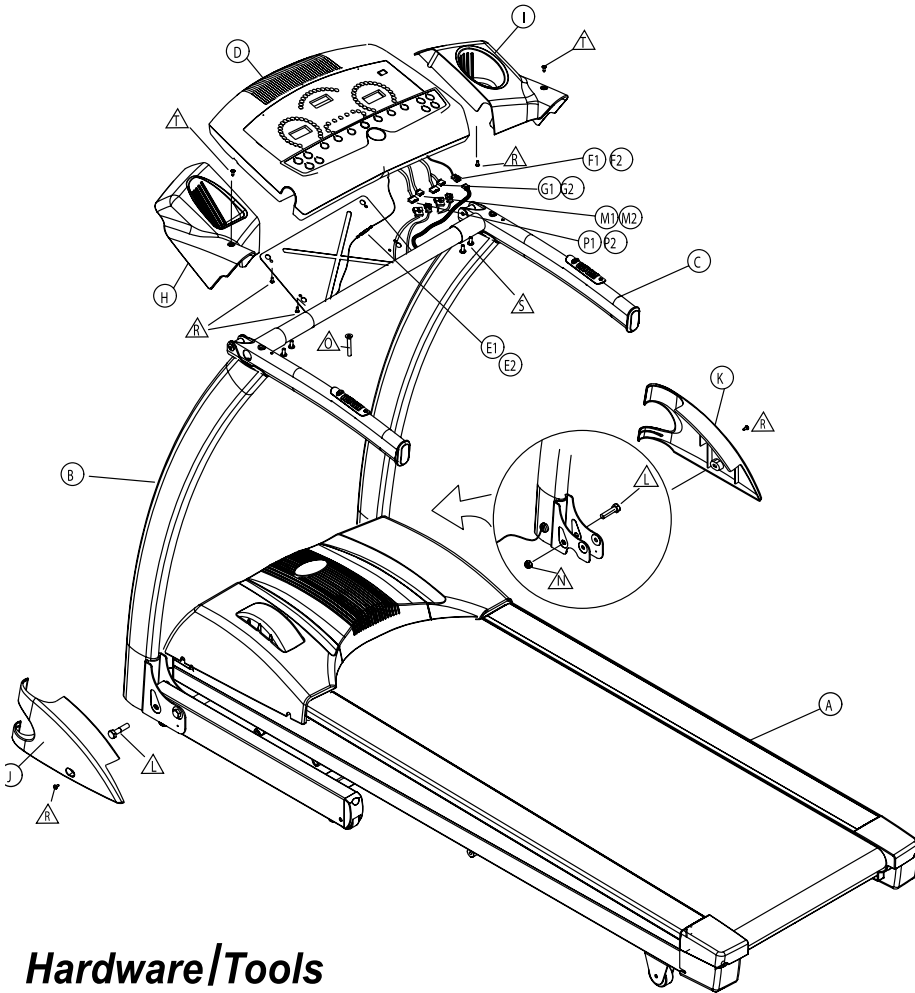





Parts



- (A) Frame
- (B) Support Handle
- (C) Handlebar
- (D) Console
- (E1) Ground Wire
- (E2) Ground Wire
- (F1) Wire Harness
- (F2) Wire Harness
- (G1) Hand Pulse Cable
- (G2) Hand Pulse Cable
- (H) Left Rack
- (I) Right Rack
- (J) Left Cover
- (K) Right Cover
- (M1) Speed Control Harness
- (M2) Speed Control Harness
- (P1) Incline Control Harness
- (P2) Incline Control Harness

Hardware/Tools

Screws Already in Place on the Treadmill

M10 X 60L (2pcs)  screw	M10 X 10t (2pcs)  nylon nut	Ø4.1 X 10L (6pcs)  screws	M8 X 15L (4pcs)  screws	Ø4.1 X 5/8L (2pcs)  screws
--	--	--	---	---

Screws in the Plastic Bag

M8 X 65L (2pcs)  screws	M4 X 20L (6pcs)  screws
--	--

TOOLS

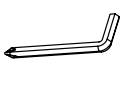
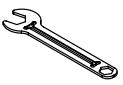
 Wrench-6mm	 Wrench-5mm	 Wrench
--	---	---

Handlebar Support Post Assembly

1. Remove screw $\triangle L$, and nut $\triangle N$ from both right/left sides of base frame.
2. Stand up the support post and handle bar. (FIG-1)

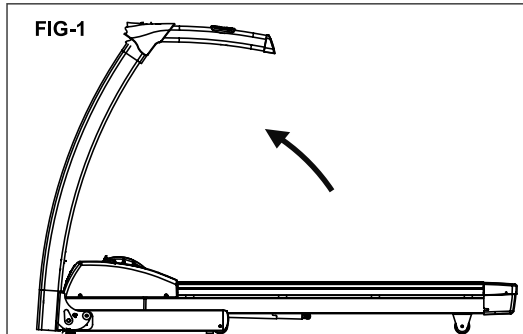

3. Attach screw $\triangle L$, and nut $\triangle N$ back to both right/left sides of base frame and tighten the screws.
4. Attach right base cover on base frame and tighten with screw $\triangle R$. Repeat the same step on the left side.

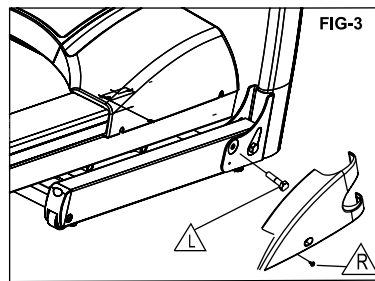
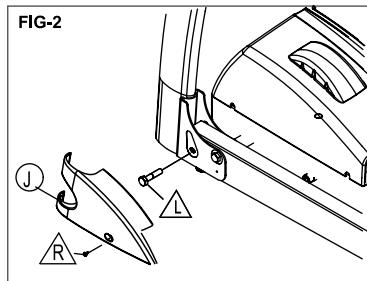

Handlebar Assembly

1. Adjust the handlebars so they are positioned on the handlebar posts. Secure the right/left handle bar on the support post by tightening the screws $\triangle O$. (FIG-4)
2. Rotate the console tube so the console bracket is positioned as shown in Figure 4.

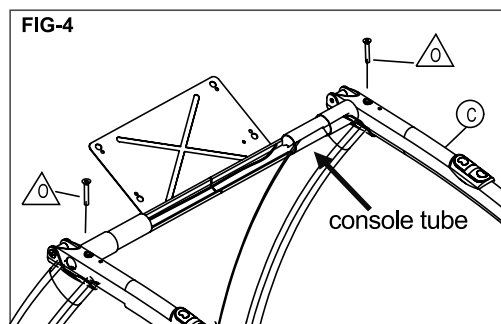

Console Assembly

1. Hold console on the console tube as shown in Figure 5.
2. Connect ground wires (E1) (E2) . (FIG-6)
3. Connect wire harness (F1) (F2) . (FIG-6)
4. Connect hand pulse cables (G1) (G2) . (FIG-6)

Note: Insert excess wire harness into right side of console tube.

6. Connect the Speed Control Harness (M1) (M2) . (FIG-6)
7. Connect Incline Control Harness (P1) (P2) . (FIG-6)
5. Fix console on the bracket by tightening 4 screws (Q) .

Warning: Make sure all the cables/wires are not pinched when the console screws are tightened.

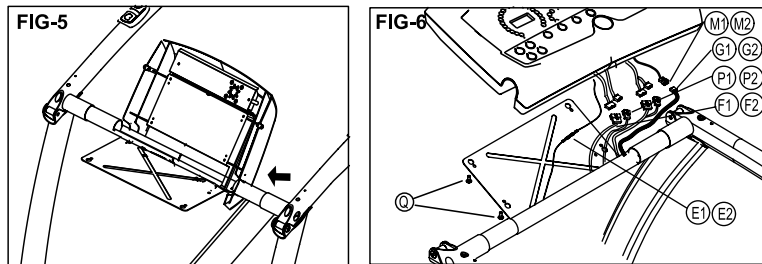

Cup Holder Assembly

1. Attach the right cup holder to the console tube and the right handlebar. Rotate the console tube if necessary to make sure the cup holder fits snugly on the handle bar.
2. Attach screw (T) from the top of the cup holder onto the handlebar and tighten.
3. Attach screw (Q) from the bottom of the cup holder to the console.
4. Repeat the above steps to fix left cup holder on handle bar. (FIG-7)

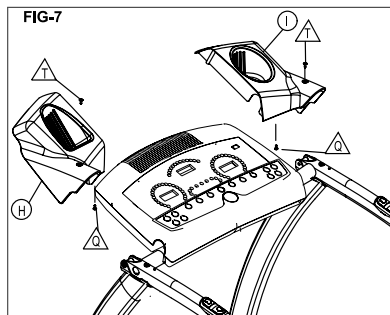

Complete Assembly

Make sure the console and the cup holders are aligned and then tighten the 4 screws (S) under both sides of console tube. (FIG-8)

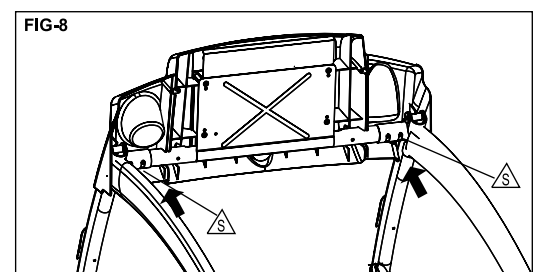

Display Functions

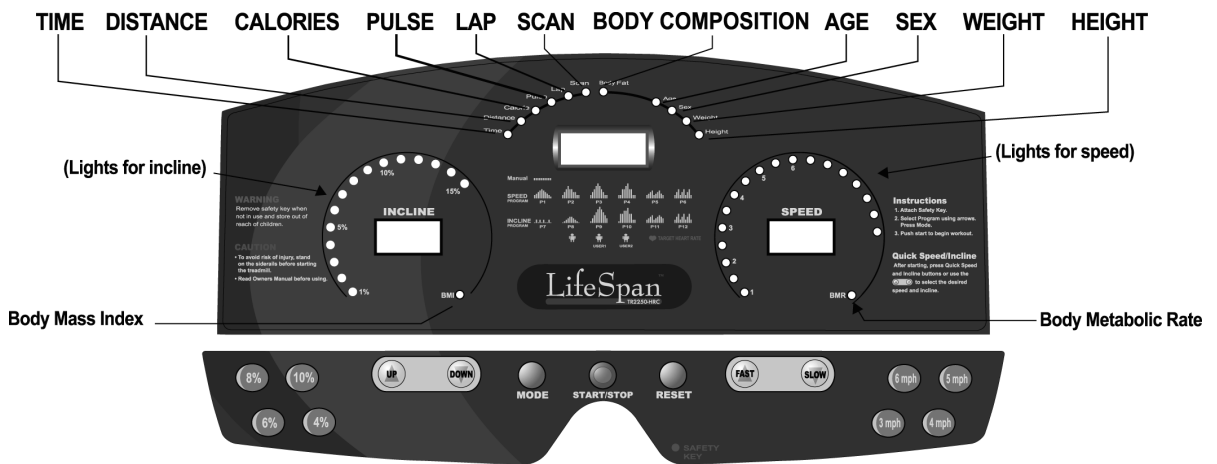

Grounding Instructions

This product must be properly grounded to work safely and properly. If a malfunction should occur, grounding provides a path for electric current and reduces the risk of electric shock.

Your LifeSpan treadmill includes a standard American ground plug. Do not alter this plug in anyway and do not bypass the ground with an adapter. Plug your treadmill into a 115 VAC/10 amp grounded electrical outlet with 115 volts measured at the treadmill. If this breaker switch has other appliances that run at the same time, you may experience problems with the breaker switch or erratic performance from your treadmill.

Using electrical power other than the one specified above will void any warranty, implied or otherwise.

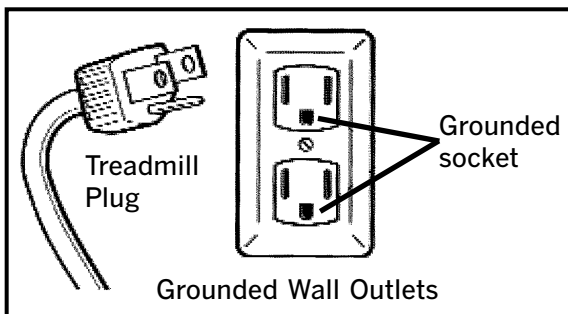

Warnings

Improper connection of the grounded plug can result in the risk of shock. Check with a qualified electrician if you have any questions or are in doubt as to whether the product is properly grounded.

Never use extension cords between the treadmill and wall outlet.

exercise programs

Speed Programs – programs P1 – P6 automatically change the speed of the treadmill throughout the workout. Each program starts at a minimum speed of 1.2 MPH and depending upon the program, can go up to a maximum speed of 6.2 MPH. The incline can be manually set by the user in any of the speed programs and this incline will remain throughout the workout unless modified by the user. The speed can also be modified, but changes to the speed will only last until the end of each specific program segment. Profiles for the speed programs are shown below:

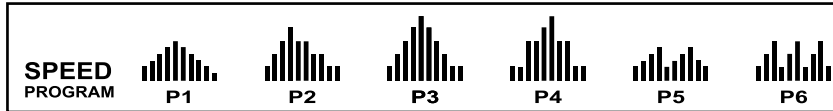

Incline Programs – programs P7 – P12 automatically modify the level of incline for the treadmill belt. In an incline program, the user sets the speed to a desired level and the program modifies the incline. The user can override the incline for any segment within the workout but at the end of each workout segment the program will override any adjustments made to the incline. The range of incline in programs P7 – P12 is from 1 to 11%. Profiles for the incline programs are shown below:

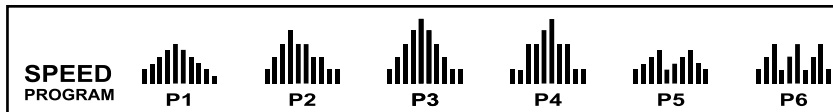

User Setup Programs – there are two user set up programs that provide the ability to establish customized workout programs specific to a users workout requirements. For each user set up program, the workout time is set and then 10 unique workout segments are set up by the user. For each segment the user can preset the speed and incline of the segment by using the up and down arrow buttons and then pushing the mode button to set each program.

Once a program is set up the user simply scrolls to the User1 or User2 program and pushes the start button. To modify the program after it is established, select the program and then push the mode button.

Target Heart Rate Program – this program automatically modifies the speed to maintain a preset target heart rate. This target is established in the setup process. The chart on page 6 of this Owners Manual should be used to determine the appropriate Target Heart Rate.

After a warm up period the TR2250 treadmill automatically adjust the speed to raise the user's heart rate to the Target level and then maintain the Heart Rate throughout the workout.

Body Composition – the TR2250 comes with 3 different body composition measures. These are Body Fat Percentage, Body Mass Index, and Basal Metabolic Rate. None of these measures are perfect and all of them should be used only as a relative gauge. These three measures are briefly described below:

- **Body Fat Percentage** is calculated using a technique called Bioelectrical Impedance Analysis (BIA). This is a simple and easy way to determine body fat by sending a signal from one hand to another while the users hands are placed on the heart rate sensors. The faster the signal travels the higher the muscle density. The results are based on the fact that muscle tissue conducts electricity faster than fat because muscle is about 70% water and fat contains almost no water.

Age	Female Range			Male Range		
	Excellent	Good	Poor	Excellent	Good	Poor
19-24	18.9 %	25.0%	29.6%	10.8%	19.0%	23.3%
25-29	18.9%	25.4%	29.8%	12.8%	20.3%	24.4%
30-34	19.7%	26.4%	30.5%	14.5%	21.5%	25.2%
35-39	21.0%	27.7%	31.5%	16.1%	22.6%	26.1%
40-44	22.6%	29.3%	32.8%	17.5%	23.6%	26.9%
45-49	24.3%	30.9%	34.1%	18.6%	24.5%	27.6%
50-54	26.6%	33.1%	36.2%	19.8%	25.6%	28.7%
55-59	27.4%	34.0%	37.3%	20.2%	26.2%	29.3%
60+	27.6%	34.4%	38.0%	20.3%	26.7%	29.8%

- **Body Mass Index (BMI)** is a scientific measure that uses a ratio of height and weight. It is a general measure of health risk, but does not take into account lean body mass. As a result, a healthy muscular individual with very low body fat can be classified as overweight. The following are general ranges of BMI measurements:

Below 20	Lean – if you are not an athlete you should consider gaining weight through good diet and exercise
Between 20 and 22	Ideal – indicates a healthy amount of body fat and the lowest incidence of serious illness
Between 25 and 30	Slightly Overweight – increased risk for a variety of illnesses. You should find ways to reduce your weight through diet and exercise.
Over 30	Overweight – indicates an unhealthy condition with a higher risk of heart disease, diabetes, high blood pressure, gall bladder disease and some cancers. You should focus on losing weight by changing your diet and increasing levels of exercise.

- **Basal Metabolic Rate** is the number of calories used by the body when it's at rest. It is calculated using age, sex, height, and weight. The BMR number shown on the display is a three digit number. You will need to add a "0" to the end of the number to get your actual BMR.

treadmill operations

Before starting your treadmill the following actions will need to be properly completed:

1. Be certain that your treadmill sits stable on the floor. It is also recommended that you locate your treadmill in a pleasant area that gives you something to look at while working out, such as a window or television. Maintaining an exercise program with a treadmill located in a poorly lit basement room is more difficult than when your treadmill is located in an active and pleasant location.
2. Make sure that your treadmill is plugged into a properly grounded outlet as described in the grounding section of this document.
3. Turn the On/Off switch, which is located in the front of your treadmill, to the On position.
4. Insert the magnetic safety key in the round area centered at the bottom of your display. If the safety key is not inserted properly you will see lines across the middle of each LED display.

QuickStart

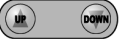
1. Attach the "Safety Key" to your clothing. This key will immediately shut off your treadmill if removed and is strongly recommended for your safety.
2. QuickStart - The quickest and easiest way to start your treadmill is to push the QuickStart button. This will cause the display to count down for 3 seconds and then begin in the "Manual Program" at .6 Miles Per Hour.
3. Speed Adjustment – can be increased and decreased in 3 different ways:
 - **Display Console** –  Each time you depress the "Fast" button on the display console the speed will increase by .1 Miles Per Hour.
 - **Handlebar Speed Control** – the heart rate sensor on the right side of the handlebars includes a speed control switch. Pushing the switch on the right side increases the speed by .1 MPH and pushing the switch on the left side decreases the speed by .1 MPH.
 - **Quick Buttons** – the display console includes buttons that immediately set the speed to 3, 4, 5, and 6 MPH without having to scroll through the speeds.
4. Incline – like the speed settings, incline can be adjusted 3 different ways:
 - **Display Console** –  Each time you depress the "Up" or "Down" button on the display console the incline will increase or decrease by 1%.
 - **Handlebar Incline Control** – the heart rate sensor on the left side of the handlebars includes an incline control switch. Pushing the switch on the left side increases the incline by 1% and pushing the button on the right side decreases the incline by 1%.
 - **Quick Buttons** – the display console includes buttons that immediately set the incline to 4, 6, 8, and 10% without having to scroll through the incline levels.

Note: Handlebar speed and incline control buttons are only available on the TR2250-HRC model.

5. Display Readouts - Besides "Speed" and "Incline" the center LED window will display Time, Distance, Calories, Heart Rate and Laps around the track. By pressing the mode button you can select the function that you want displayed on the center window, or you can go to the scan mode to scan through all functions. In the "Quick Start" mode, time will start to count up from 0:00.

Programs Setup and Selection – P1 - P12

1. **Select Program:** To Start a program simply select the desired program by pressing on either the "Up" and "Down" or "Fast" and "Slow" buttons and then pressing the "Mode" button.
2. **Set Time:** Now chose how long you would like to workout by pressing either set of "Up" and "Down" arrows. Each time you push the up or down button the workout time will change by one minute. You can also hold these buttons down to quickly scroll through the time.

The shortest preset program time is 10 minutes and the longest is 99 minutes.

4. **Press Start:** Once the desired time is selected, push the "Quick Start" button to begin your workout.

User Setup Programs

1. **Select Program:** Use either set of "up" and "down" arrows to scroll through the programs until you reach U1 or U2 and press the "Mode" button.
2. **Set Time:** Chose how long you would like to workout by pressing either set of "up" and "down" and press the "Mode" button.
3. **Enter Segment Speed and Incline:** each program is divided into 10 equal segments. Select the desired speed for each segment by pressing on the "Fast" and "Slow" buttons. Then select the desired incline for each segment by pressing on the "Up" and "Down" arrows. After selecting the incline and speed for the segment press the "Mode" button and make the selection for the next segment until all 10 segments are completed. Press the "Start" button to begin the workout.
4. **Editing a User Setup Program:** To edit the program, scroll to either "U1" or "U1" programs and press the "Mode" button. Make the desired changes to the program and press "Mode" at the end of each segment. Press the "Start" button once completed.

Note: After a user program has been set, to select that program for subsequent workouts, use the up and down arrows to scroll to "U1" or "U2" and press the "Start" button.

Body Composition Analysis

1. **Select Program:** Use either set of "up" and "down" arrows to scroll through the programs until you reach the "FAT" composition program and press the "Mode" button.
2. **Enter Height:** Use either set of "up" and "down" arrows to select your height in inches and press the "Mode" button.
3. **Enter Weight:** Use either set of "up" and "down" arrows to select your weight and press the "Mode" button.
4. **Select Sex:** Press the mode button for a "female" selection or press either set of "up" or "down" buttons to scroll to the "male" selection and then press the "Mode" button. Because of the limitations of the LED display these selections are shown as "girl" and "boy" on the display console.
5. **Press Start:** After all selections are made, press the start button and place both hands over the heart rate sensors on the handlebars. It will take several seconds for the system

to calculate each readout. If after waiting for 10 seconds the system doesn't show your readouts, it is not getting a good reading from the heart rate sensors. This can generally be solved by walking on the treadmill at an average speed for 3-4 minutes to increase your heart rate and improve the signal pickup from the heart rate sensors.

Target Heart Rate Program Setup

1. **Select Program:** Use either set of “up” and “down” arrows to scroll through the programs until “H1” is on the center display. Then press the “Mode” button.
2. **Select Age:** Use either set of “up” and “down” arrows to select the user age. Then press the “Mode” button.
3. **Set Target Heart Rate:** Use either set of “up” and “down” arrows to set the target heart rate. Then press “Mode”. After a warm-up period, the program will automatically adjust the speed to maintain the Target Heart Rate.
4. **Enter Program Time:** Use either set of “up” and “down” arrows to select the program workout time. Then press the “Start” button.

Note: The TR2250-HR supports the Target Heart Rate Program through the Heart Rate Sensors on the handlebar. The TR2250-HRC supports the Target Heart Rate Program using the Heart Rate Sensors on the Handlebars and through the use of the supplied chest strap.

Pause Function

Pause the treadmill at any time during the operation by pressing the “Stop” button once. To resume operations, press the “Start” button.

Reset Button

Pressing the “Reset” button will reset the console to the beginning of the program setup process.

At The End Of Every Exercise Session Always...

1. Remove the Safety Key from the computer console.
2. Use the master power switch to turn the treadmill off. The master power switch is located at the front of the treadmill.
3. Always position and store the electrical cord where it is clear from all pathways.
4. Unplug the electrical cord from the electrical outlet. This is especially important if you are not going to use your treadmill for extended periods.
5. Wipe all treadmill surfaces with a dry cloth or towel especially perspiration on the handlebars, control panel, running belt or other treadmill components.

moving and storage

The treadmill comes with a folding feature that reduces the amount of storage space required when your treadmill is not in use and makes the treadmill easier to move.

Folding the Treadmill

1. Make sure that the On/Off switch is turned Off and the power cord is removed from the wall.
2. Make sure that nothing is on or near your treadmill which might spill, be knocked over or prevent the treadmill from completely folding.
3. (a.) Place both hands under the support bar that is located directly under the back of the running belt on your treadmill to make sure that you have a solid lifting point

(b.) Lift the treadmill all of the way forward and make sure that the hydraulic shock is properly locked in place.

Caution: When lifting, use proper safety precautions and lifting techniques. Bend your knees and elbows, keep your back straight and pull up evenly with both arms.

- (c.) Ensure that the locking mechanism is secure by gently pulling back on the treadmill and make sure that it doesn't move. When doing this, be careful to be securely positioned in case the treadmill lock has not engaged.

Caution:

- *Do not fold the treadmill by lifting on the running belt or rear roller. These parts do not lock in place and are difficult to grip when folding - personal injury or damage to the treadmill could result.*
- *Do not lean against the treadmill once it is folded or place items on it that could cause it to become unstable or fall over. This could result in serious personal injury.*
- *Do not connect the power cord when the treadmill is folded or try to operate the treadmill in the folded position*

Unfolding the Treadmill

1. Make sure that you have adequate space to lay down the treadmill and that the surface is level and solid. If you plan on using the treadmill when unfolded, there should be at least two feet of clear surface on both sides and the front, and four feet of available surface in the back.
2. Inspect to ensure that nothing is on or near your treadmill that might spill, be knocked over or prevent the treadmill from completely unfolding.
3. Position yourself behind the treadmill. With your right hand, slightly push the treadmill towards the display with your right hand. This will relieve any pressure on the locking mechanism. With your left hand, pull the locking pin to release the pin and allow the treadmill to unfold to the ground. Remember that the TR2250 comes with an easy drop system, so that you don't have to support the treadmill while it is unfolding.

trouble shooting

The treadmill is designed and manufactured to be reliable and easy to use. However, if you have a problem, these troubleshooting steps may help you find the cause.

Problem: The console lights do not light up.

Solution: Check to make sure that the treadmill is properly plugged-in, the On/Off switch is turned to the "On" position, and Safety Key is attached.

Problem: The belt does not stay in the center of the treadmill when in use.

Solution: First check to make sure that the treadmill is level, then refer to the instructions in this manual on how to tension and adjust the belt.

Problem: The treadmill motor seems strained or the fuse becomes blown.

Solution: The lubricating silicon that is applied to the deck and belt is wearing down and the belt needs to be lubricated with silicon spray.

Problem: The treadmill belt slips during use.

Solution: The belt may need to be tensioned after a period of use. Refer to the Belt Tensioning and Adjustment Section of this manual.

Problem: The motor is straining to keep the belt moving.

Solution: The LifeSpan treadmill belt is pre-lubricated at the factory with a silicon lubricant. Occasionally you may need to re-apply silicon spray lubricant to keep the belt

maintenance and cleaning

Belt Tensioning

If the belt begins to slip during use, it will need to be tensioned. Your treadmill is equipped with tension bolts that are accessible from the back of the treadmill. Before tensioning the belt, start the treadmill and set the speed to 3 MPH. Using a 6 mm Allen Wrench, included in your hardware bag, turn the right and left tension bolts 1/2 turn, alternating back and forth until the belt slipping stops. After you adjust each side 1/2 turn, test to see if the slipping is eliminated. If the belt still slips repeat this step and test again.

If you turn one side more than the other, the belt will start to drift to the side of the treadmill and need to be aligned.



Aligning the Running Belt

Ensure the running belt is centered on your treadmill at all times. Running style and a non-level surface are two instances that may cause the belt to drift off center. Minor adjustments to the two bolts at the rear of the treadmill are necessary when the belt has drifted off center.

1. Press "START" to begin running belt, then increase the treadmill's speed to 3MPH.
2. Stand at the rear of the treadmill to determine which direction the belt is drifting.
3. If the belt drifts to the left, turn the left adjustment bolt one-quarter turn clockwise and the right adjustment bolt one-quarter turn counter-clockwise. (See FIG.C)
4. If the belt drifts to the right, turn the left adjustment bolt one-quarter turn counter-clockwise and the right adjustment bolt one-quarter turn clockwise. (See FIG.D)
5. Observe the tracking of the belt for about two minutes. Repeat step 3, 4 and 5 as needed.

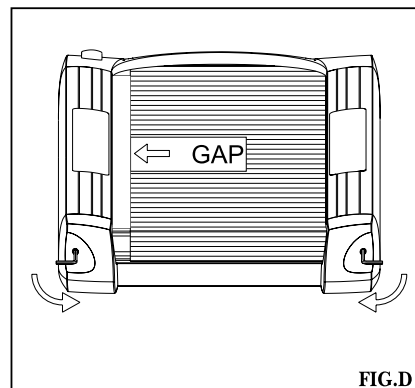
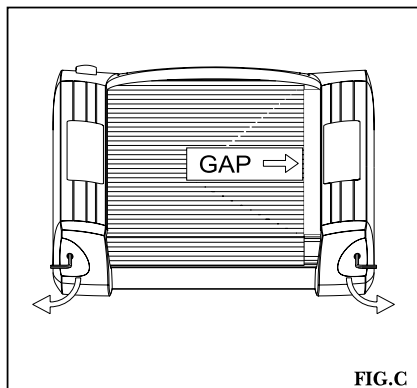

Belt Lubrication

You should lubricate the belt on the TR1000 every 200 hours of use or if you feel the treadmill straining to move the belt during normal use.

Note: If the belt loses its lubrication it will place stress on the motor and electronics during operation and increase the chance of product damage.

Use a non-petroleum base silicon spray. You can purchase belt lubricants from www.treadmilldoctor.com or we recommend a silicon spray from Napa Auto parts. When purchasing the silicon spray you will need a lubricant that includes an extension nozzle.

To lubricate the belt, keep the treadmill in its normal operating position, turn it on and set the speed to 3 MPH. Add the extension nozzle to the spray can and insert the nozzle into the gap in treadmill frame between the side rail and the steel frame. Make sure that the nozzle goes through the gap in the frame and behind the bottom of the treadmill belt on the underside of the treadmill. With the treadmill running at 3 MPH spray the silicon for 5-6 seconds.

Refer to the picture below to see the correct location for the silicon nozzle.

Note: When lubricating the belt, make sure that the treadmill is located on a surface that can be easily cleaned. Do not over spray. After completing the lubrication, fold the treadmill and clean off any excess silicon spray from the bottom of the treadmill and the floor or matt.

Make sure the area has adequate ventilation and refer to all safety precautions from the silicon manufacturer.

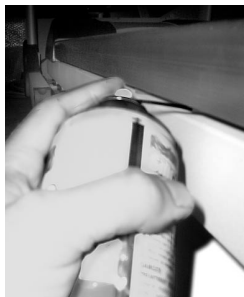

Cleaning

After use, wipe down your treadmill with a soft cloth. On a regular basis, you will also want to clean the treadmill using a mild detergent to remove all dirt and salt from the belt, painted parts and the display.

Avoid getting dirt and other materials on the belt as these materials can work their way under the belt and damage your treadmill or cause components to wear prematurely.



435-940-1180

www.lifespanfitness.com

P.O. Box 981316

Park City, Utah 84098-1316