

LifeFitness

Arctic Silver 95TW Treadmill

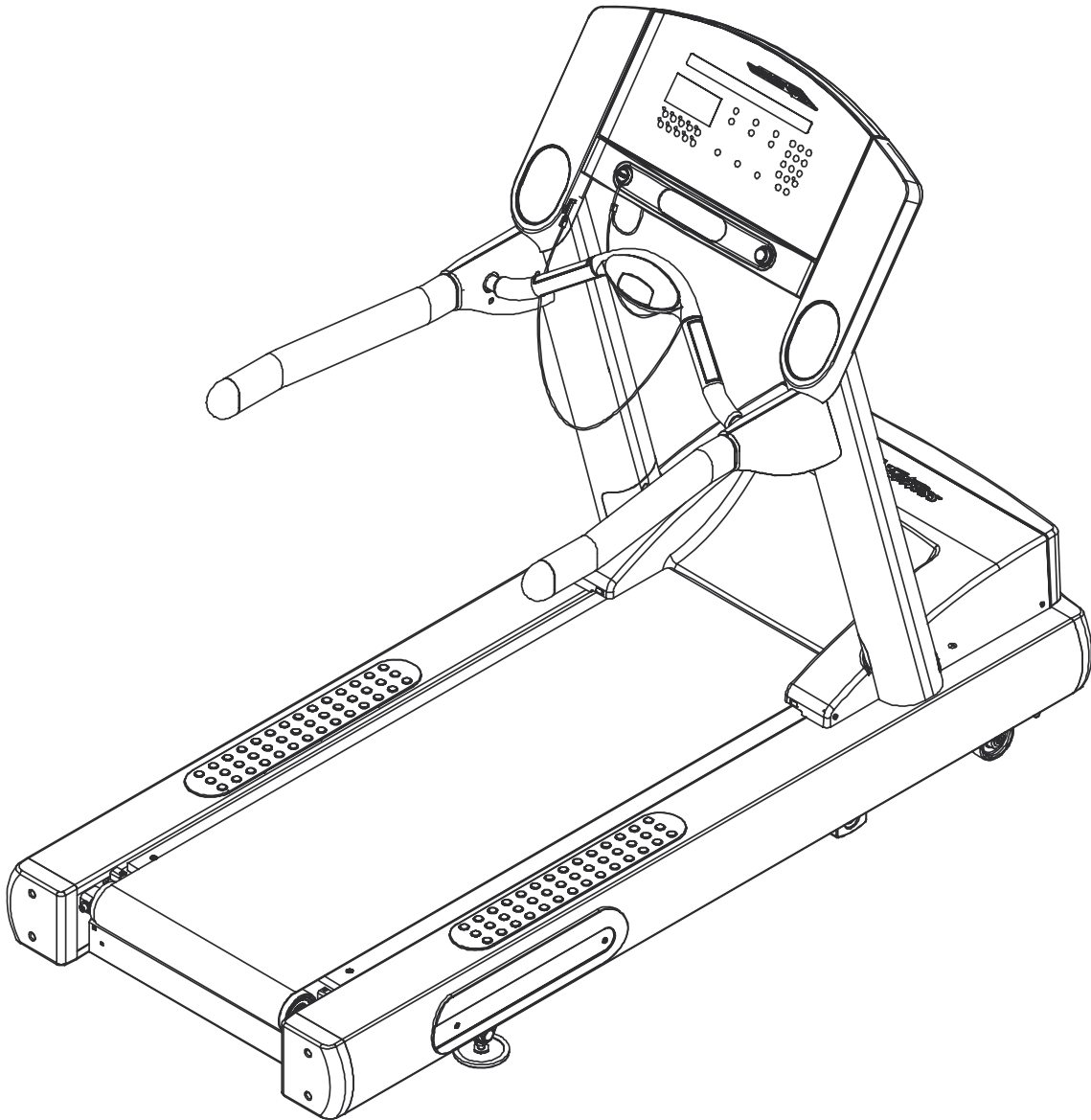

Customer Support Services
PARTS MANUAL rev 03 Jul 2008

OPERATION MANUAL	M051-00K58-A177
SERVICE MANUAL	M051-00K58-A159
ACCESS PLATE ASSEMBLY CONSISTS OF: 1) CONNECTOR PLATE 2) F TYPE CONNECTOR	AK58-00329-0000 0K58-01392-0000 0017-00021-2846
COAX CABLE	AK32-00020-0002
POWER CABLE	AK32-00078-0001
HARDWARE BAG	AK58-00226-0000
TOUCH UP PAINT: SPRAY CAN .5 OZ BOTTLE W/APPLICATOR .33 OZ PEN	0017-00008-0204 0017-00008-0205 0017-00008-0206
INSTALLATION VIDEO	M051-00K58-A160
SERVICE VIDEO	M051-00K58-A161

**NOTE: ADDING THE LCD BOLT-ON SCREEN TO THE
95TW-0XXX-03 MAKES THE UNIT A 95TER-0XXX-03.**

	Page
REAR ENDCAPS AND CUP HOLDERS	4
SCUFF PAD, TINSEL AND FRAME TAG BOARD	5
CONSOLE AND RELATED COMPONENTS.....	6
UPRIGHTS, HANDRAILS AND ERGO BAR	7
MOTOR COVER, FRONT COVER AND ENDCAPS	8
BELT, DECK AND REAR ROLLER.....	9
LIFT FRAME AND MOTOR	10
WAX/LIFT ASSEMBLY	11
MOTOR CONTROLLER ASSEMBLY.....	12
DRIVE MOTOR ASSEMBLY	13
IDLER ARM ASSEMBLY AND STATIC BRUSH.....	14
LEG LEVELER ASSEMBLY	15
FRONT ROLLER ASSEMBLY	16
ERGO BAR WITH LIFE PULSE.....	17
POWER COMPONENTS SCHEMATIC 1	18
POWER COMPONENTS SCHEMATIC 2	19
CABLES.....	20

ARCTIC SILVER 95TW
Rear End Caps and Cup Holders

95TW-0XXX-03
S/N WTE100000 and up

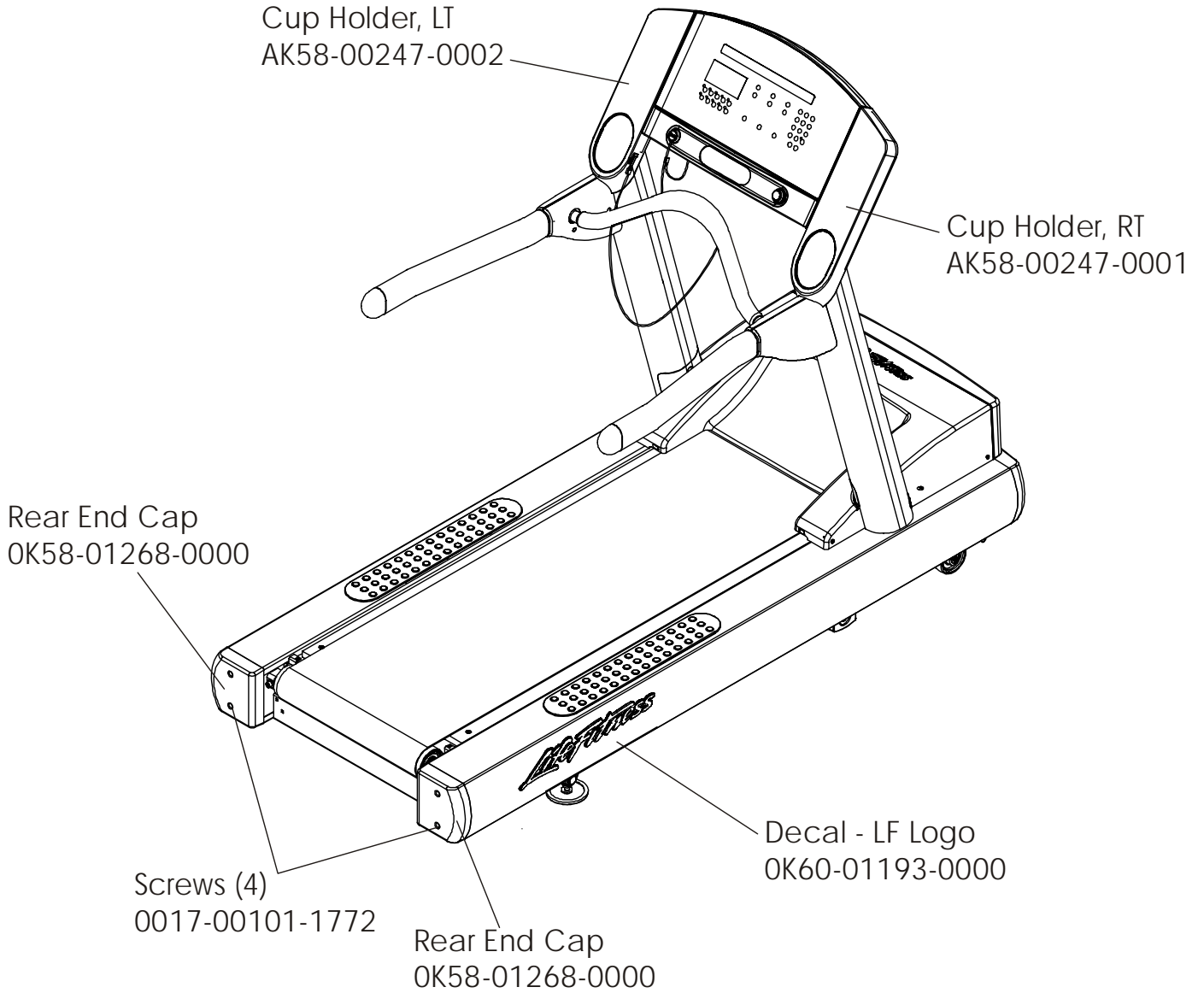

ARCTIC SILVER 95TW
Scuff Pad, Tinsel and Frame Tag Bd.

95TW-0XXX-03
S/N WTE100000 and up

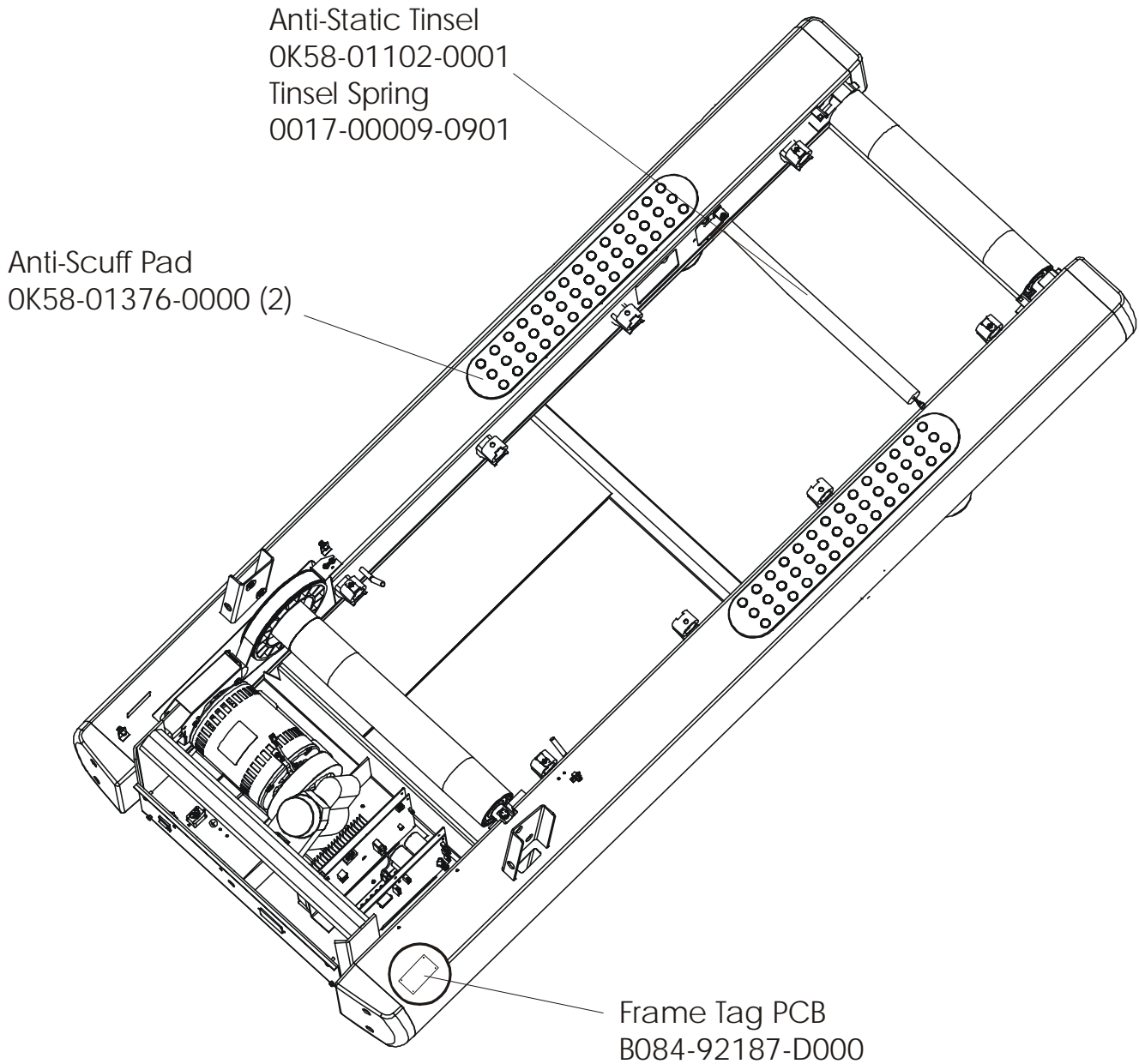

ARCTIC SILVER 95TW

Console and Related Components

95TW-0XXX-03
S/N WTE100000 and up

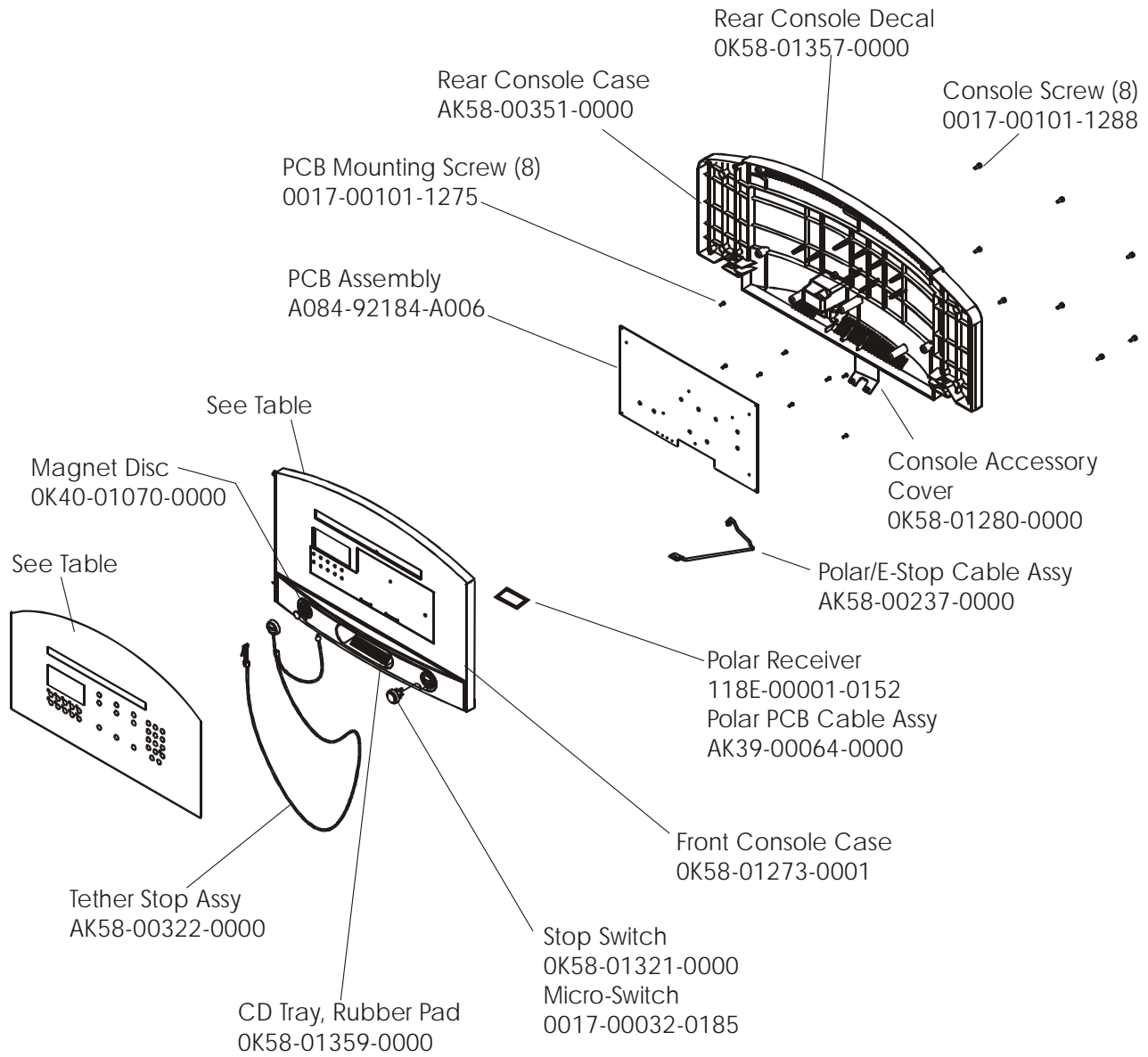

Console Assembly	Overlay/Bezel/Switch Assy.	Overlay	Language
AK58-00438-0001	AK58-00203-0001	OK58-01298-0001	Eng/Met
AK58-00438-0002	AK58-00203-0001	OK58-01298-0001	Eng/Eur
AK58-00438-0003	AK58-00203-0003	OK58-01298-0003	German
AK58-00438-0004	AK58-00203-0004	OK58-01298-0004	Spanish
AK58-00438-0006	AK58-00203-0006	OK58-01298-0006	Japanese
AK58-00438-0007	AK58-00203-0007	OK58-01298-0007	French
AK58-00438-0008	AK58-00203-0008	OK58-01298-0008	Italian
AK58-00438-0009	AK58-00203-0009	OK58-01298-0009	Dutch
AK58-00438-0010	AK58-00203-0010	OK58-01298-0010	Portuguese

ARCTIC SILVER 95TW

Uprights, Handrails and Ergo Bar

95TW-0XXX-03
S/N WTE100000 and up

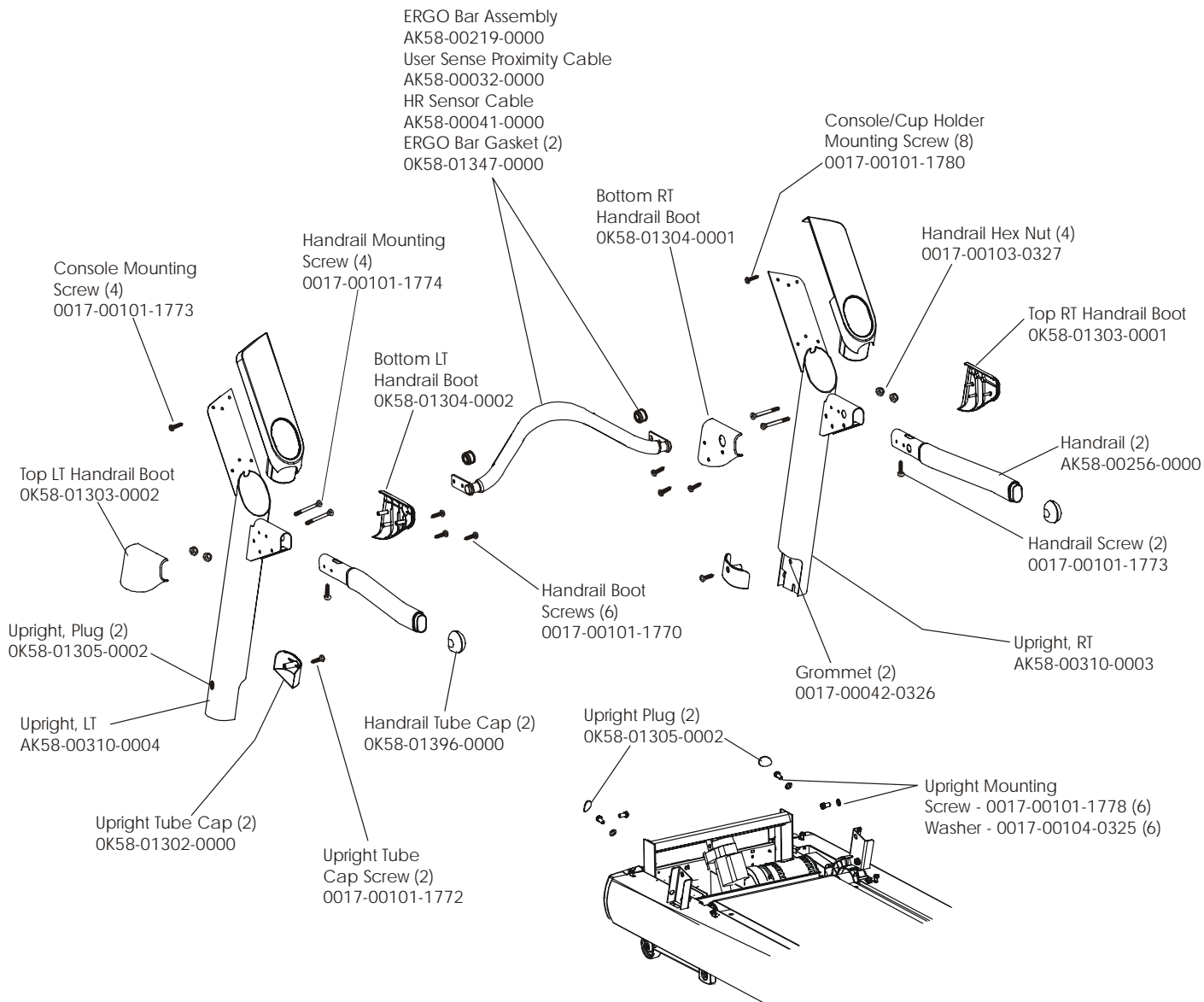

ARCTIC SILVER 95TW
Motor Cover, Front Cover and Front
End Caps

95TW-0XXX-03
S/N WTE100000 and up

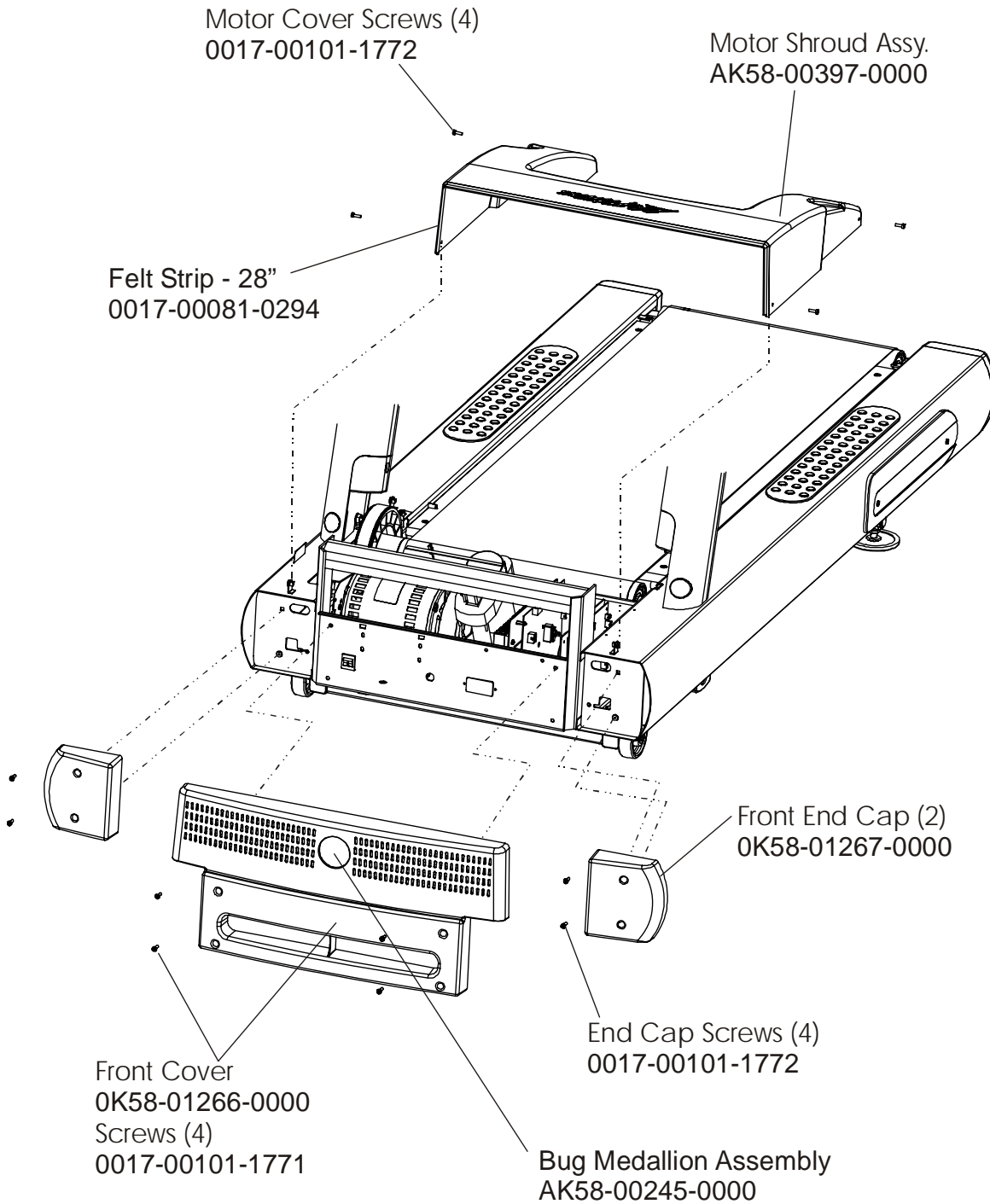

ARCTIC SILVER 95TW
Belt, Deck and Rear Roller

95TW-0XXX-03
S/N WTE100000 and up

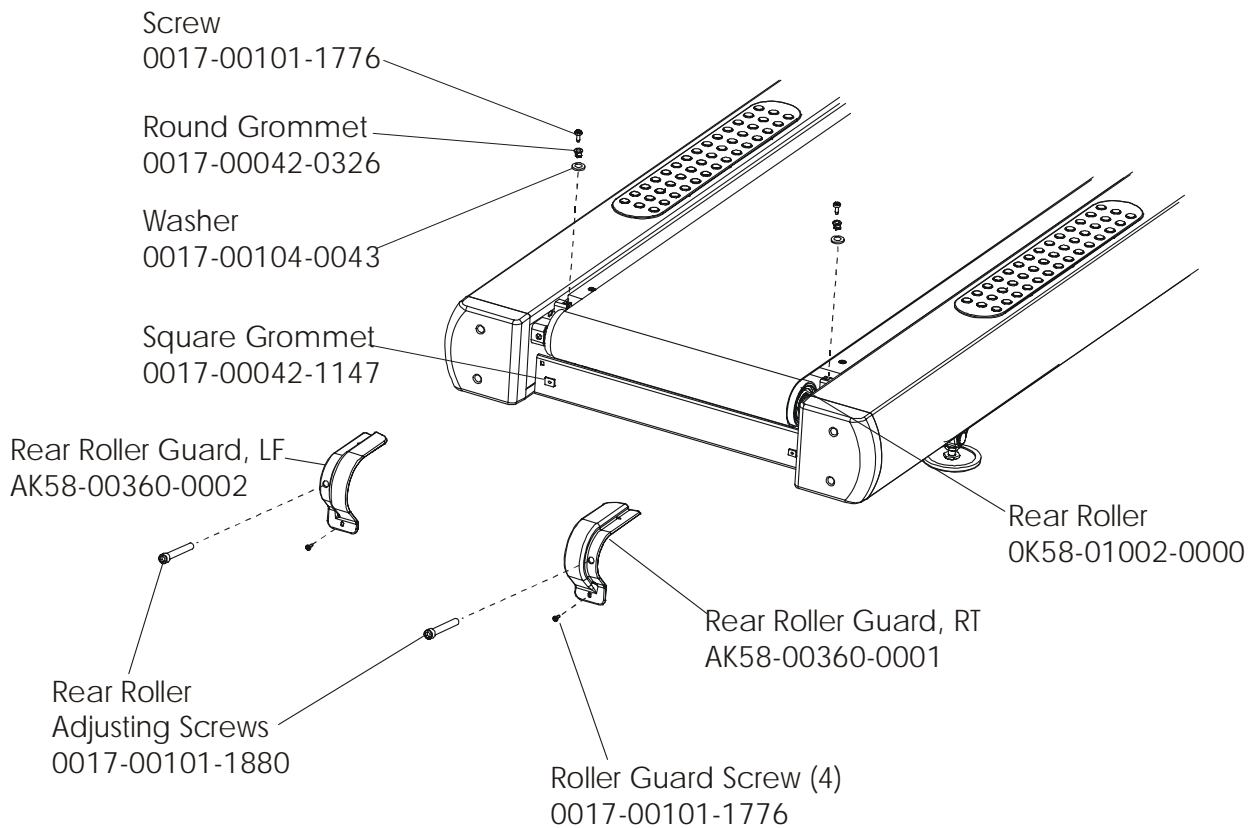
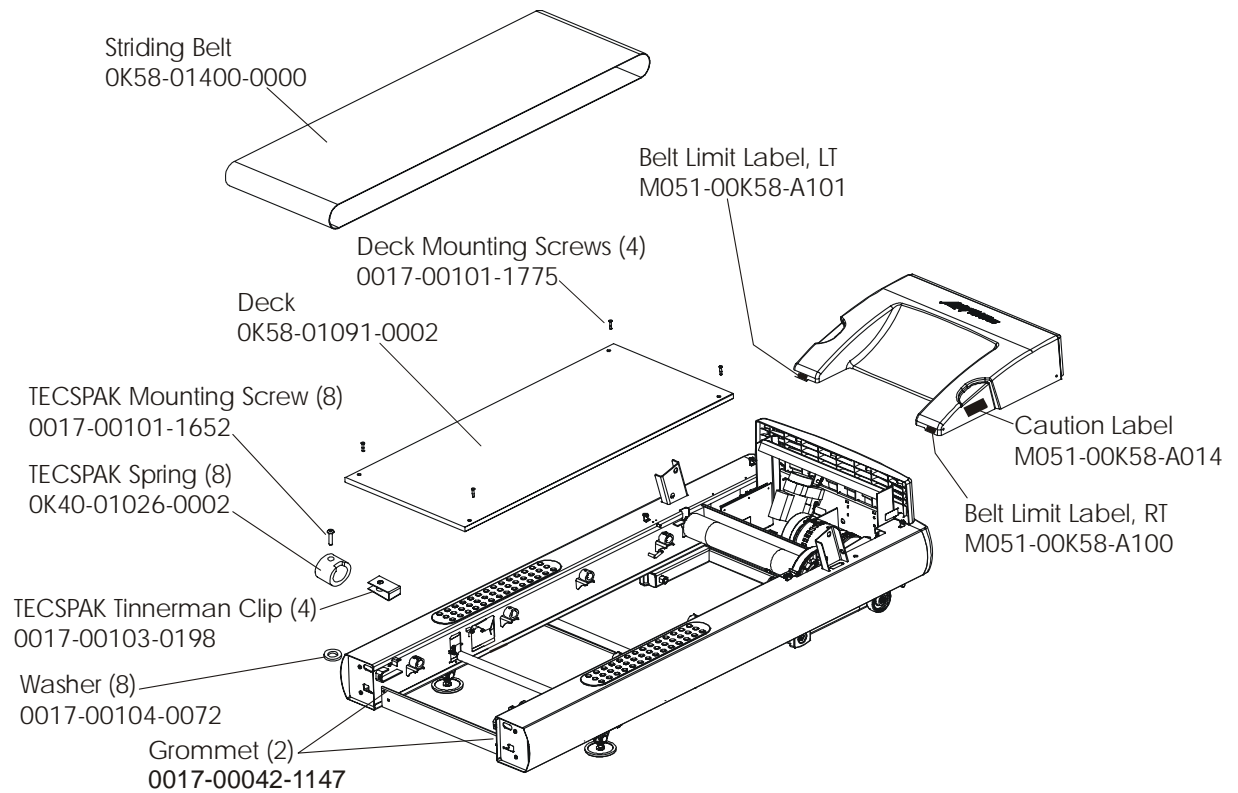

ARCTIC SILVER 95TW

Lift Frame and Lift Motor

95TW-0XXX-03

S/N WTE100000 and up

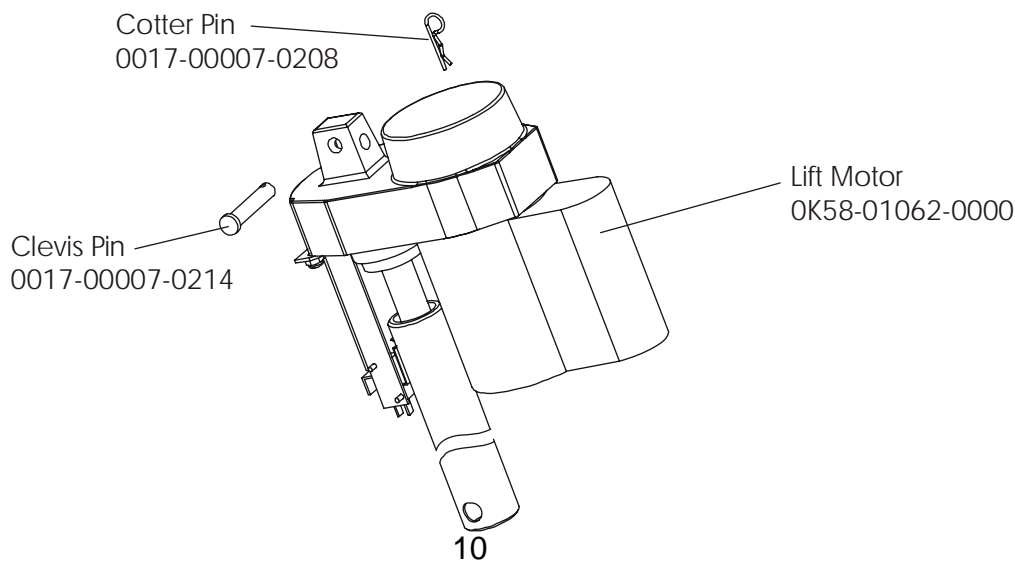
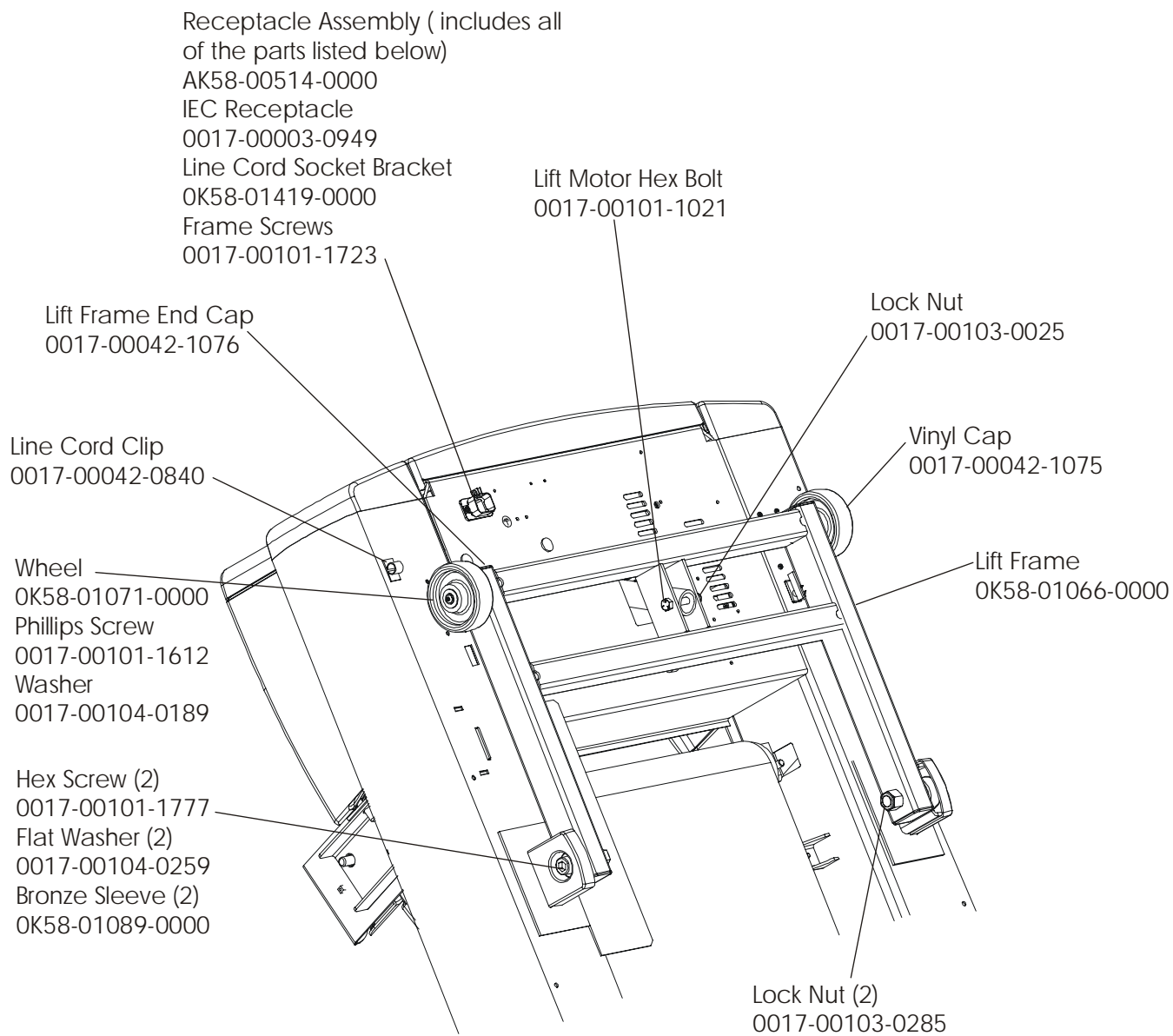

ARCTIC SILVER 95TW
Wax/Lift Assembly-AK58-00243-0000

95TW-0XXX-03
S/N WTE100000 and up

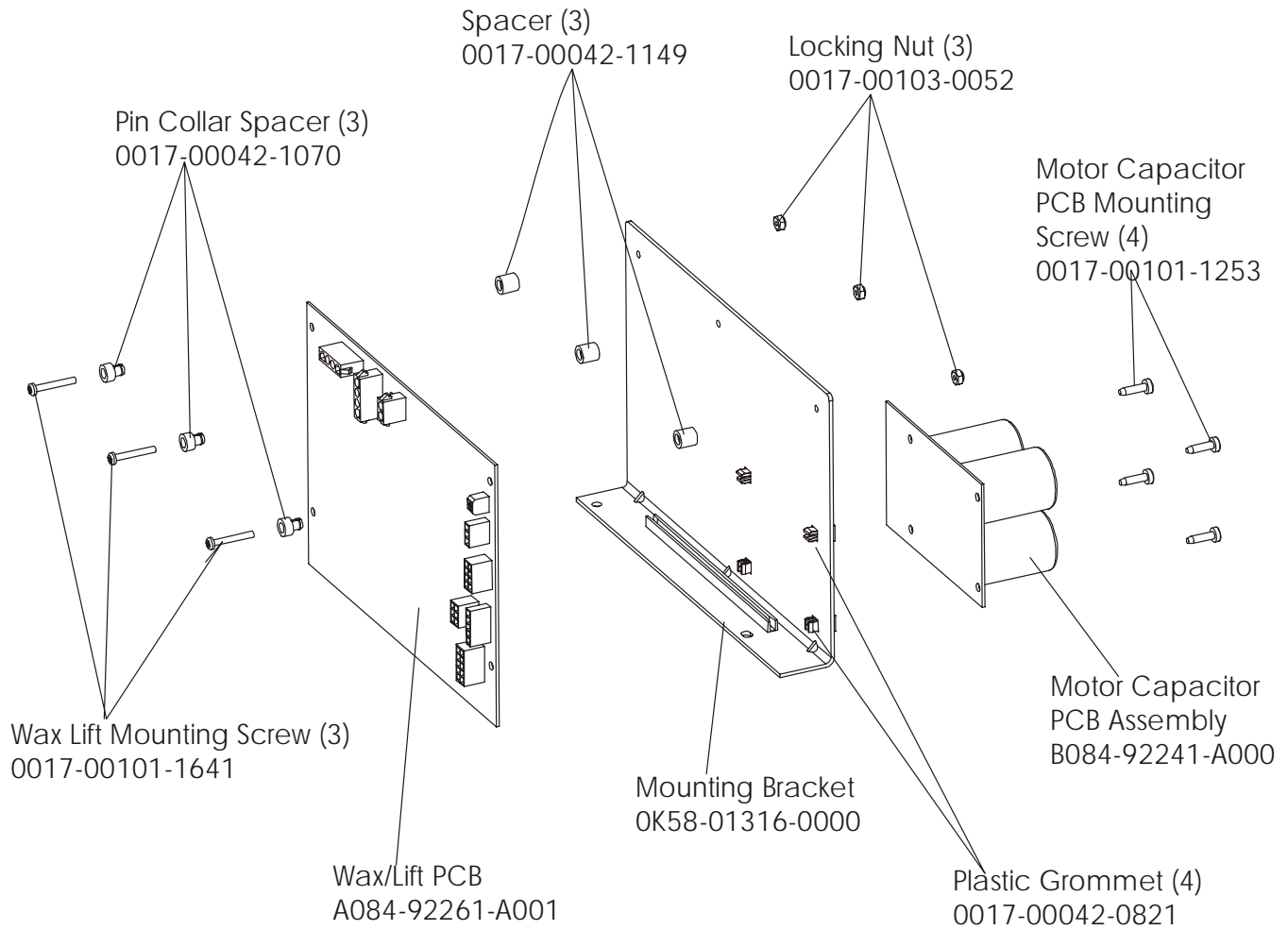

ARCTIC SILVER 95TW

Drive Motor Assembly

95TW-0XXX-03

S/N WTE100000 and up

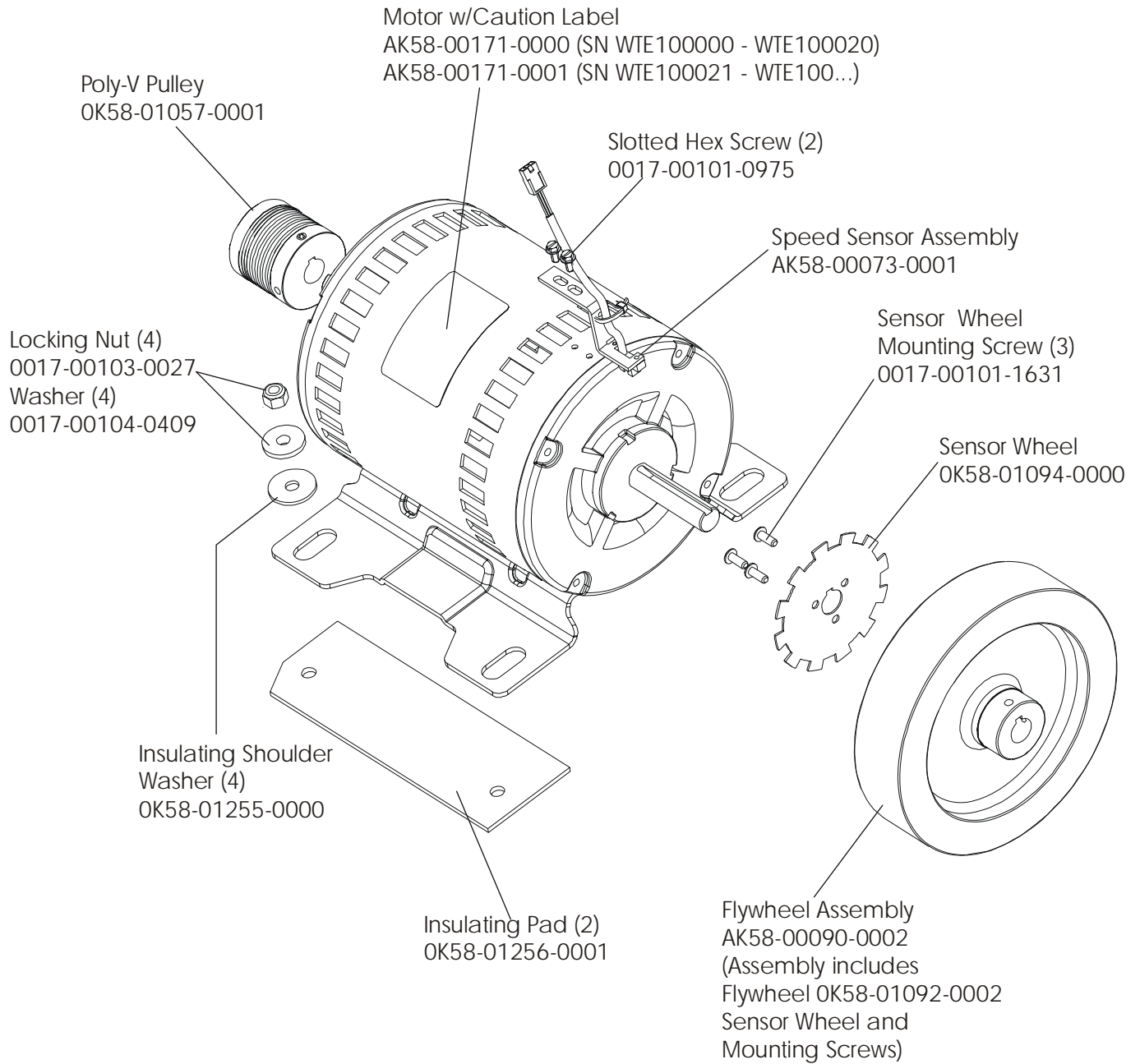

Drive Motor Assembly Number	Motor Serial Number
AK58-00172-0000	WTE100000 – WTE100020
AK58-00172-0002	WTE100021 and up

ARCTIC SILVER 95TW
Idler Arm Assembly and Static Brush

95TW-0XXX-03
S/N WTE100000 and up

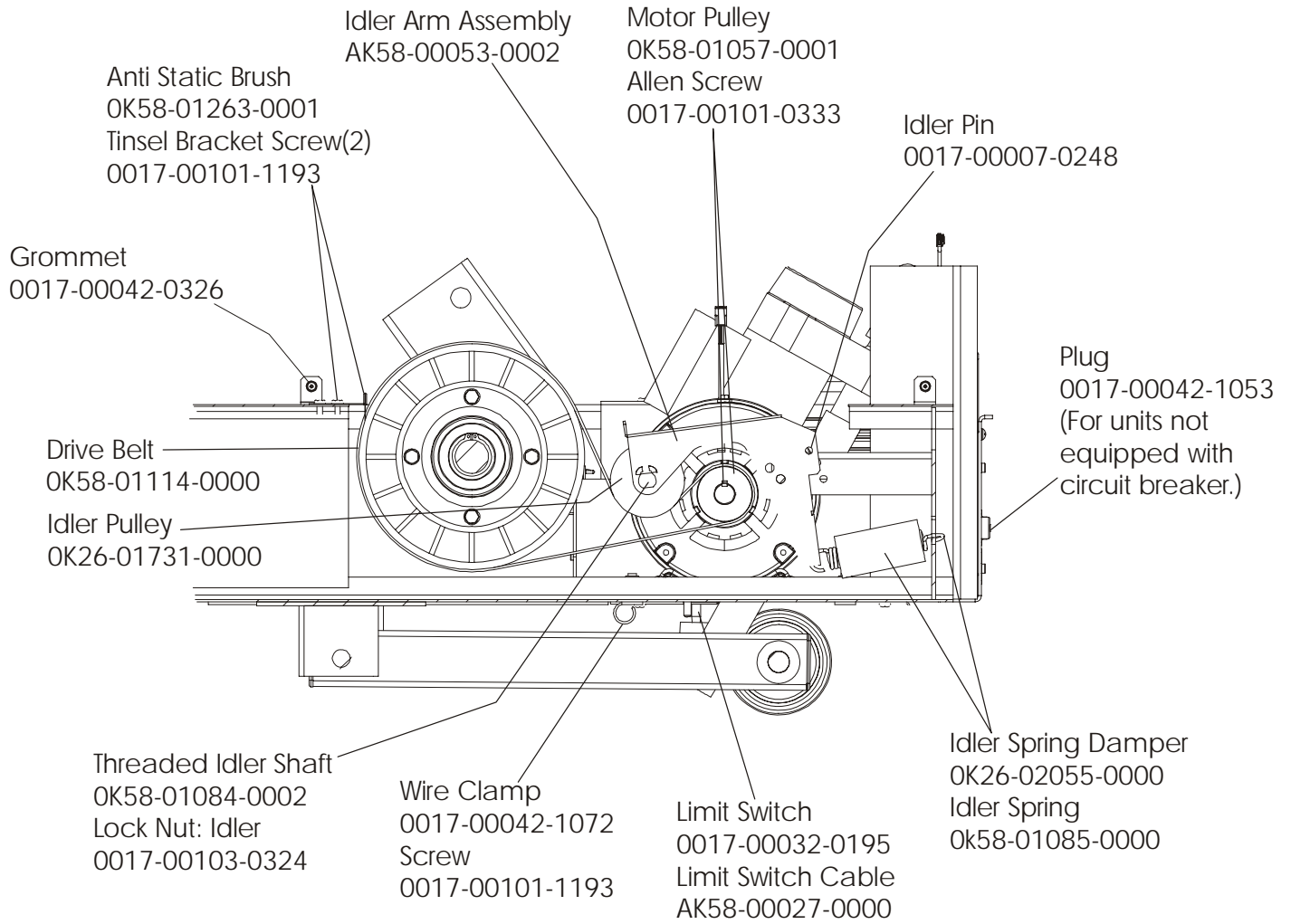

ARCTIC SILVER 95TW
Leveler Assembly – AK58-00370-0000

95TW-0XXX-03
S/N WTE100000 and up

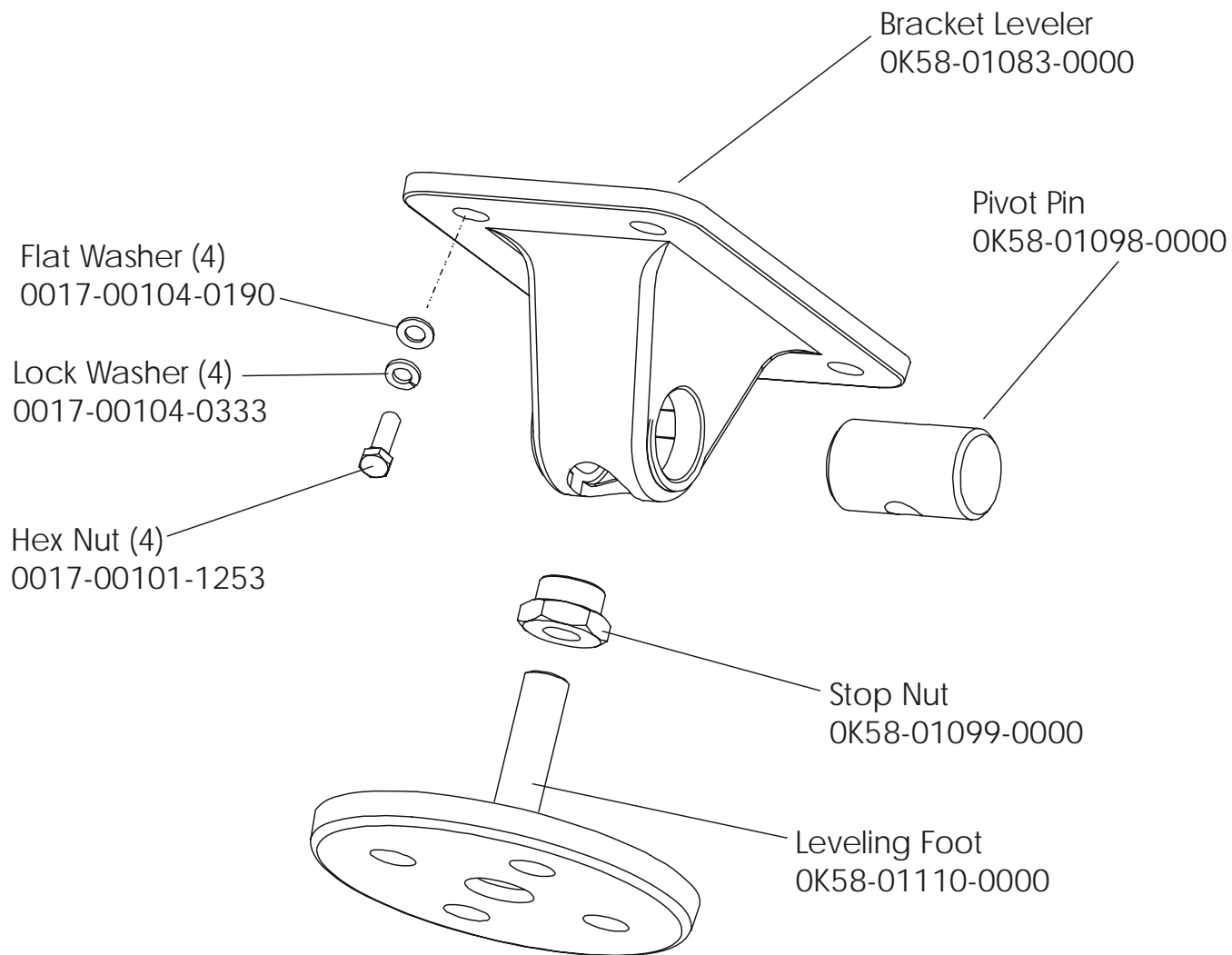

ARCTIC SILVER 95TW
Front Roller Assy.-AK58-00066-0000

95TW-0XXX-03
S/N WTE100000 and up

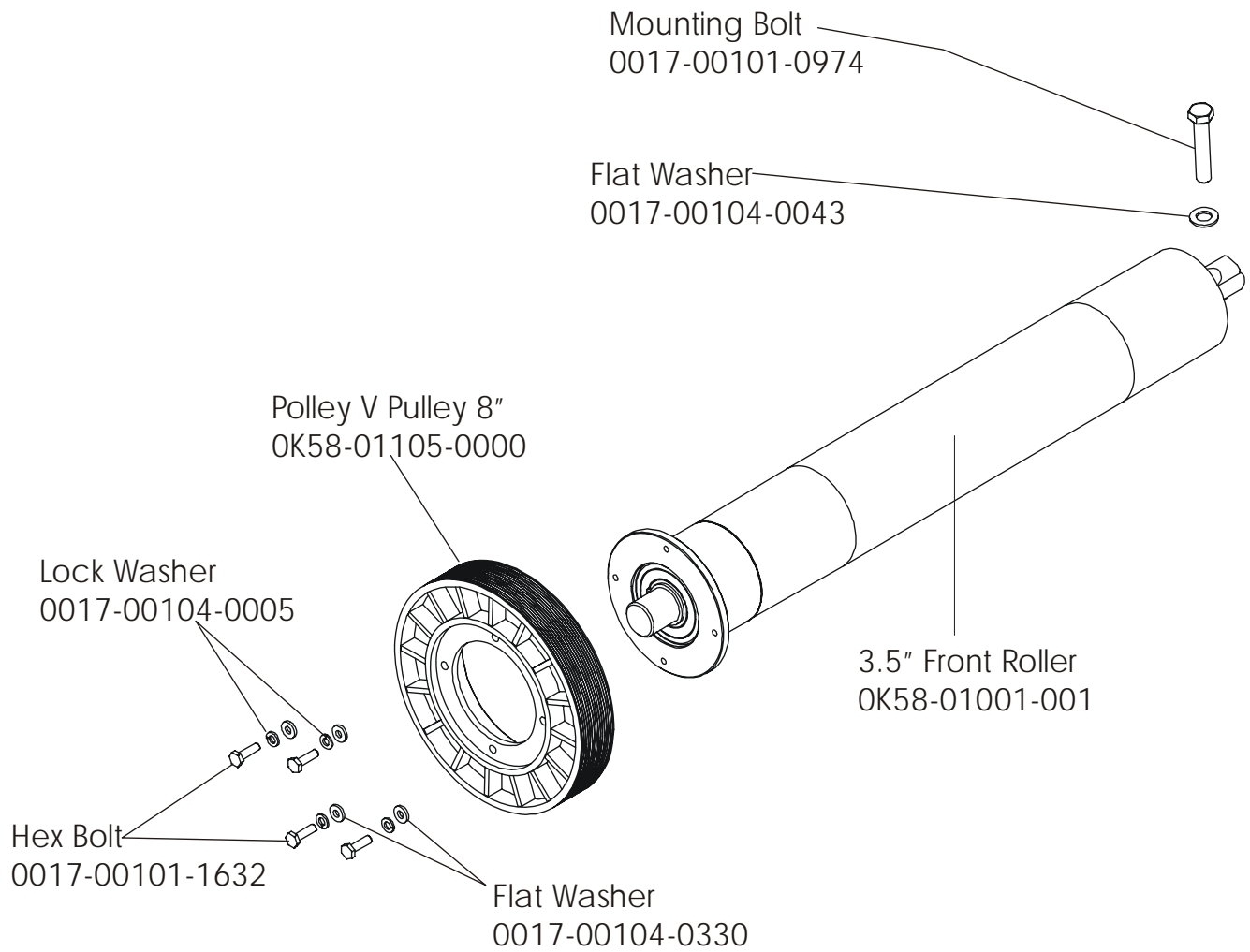

ARCTIC SILVER 95TW
Ergo Bar w/Lifepulse

95TW-0XXX-03
S/N WTE100000 and up

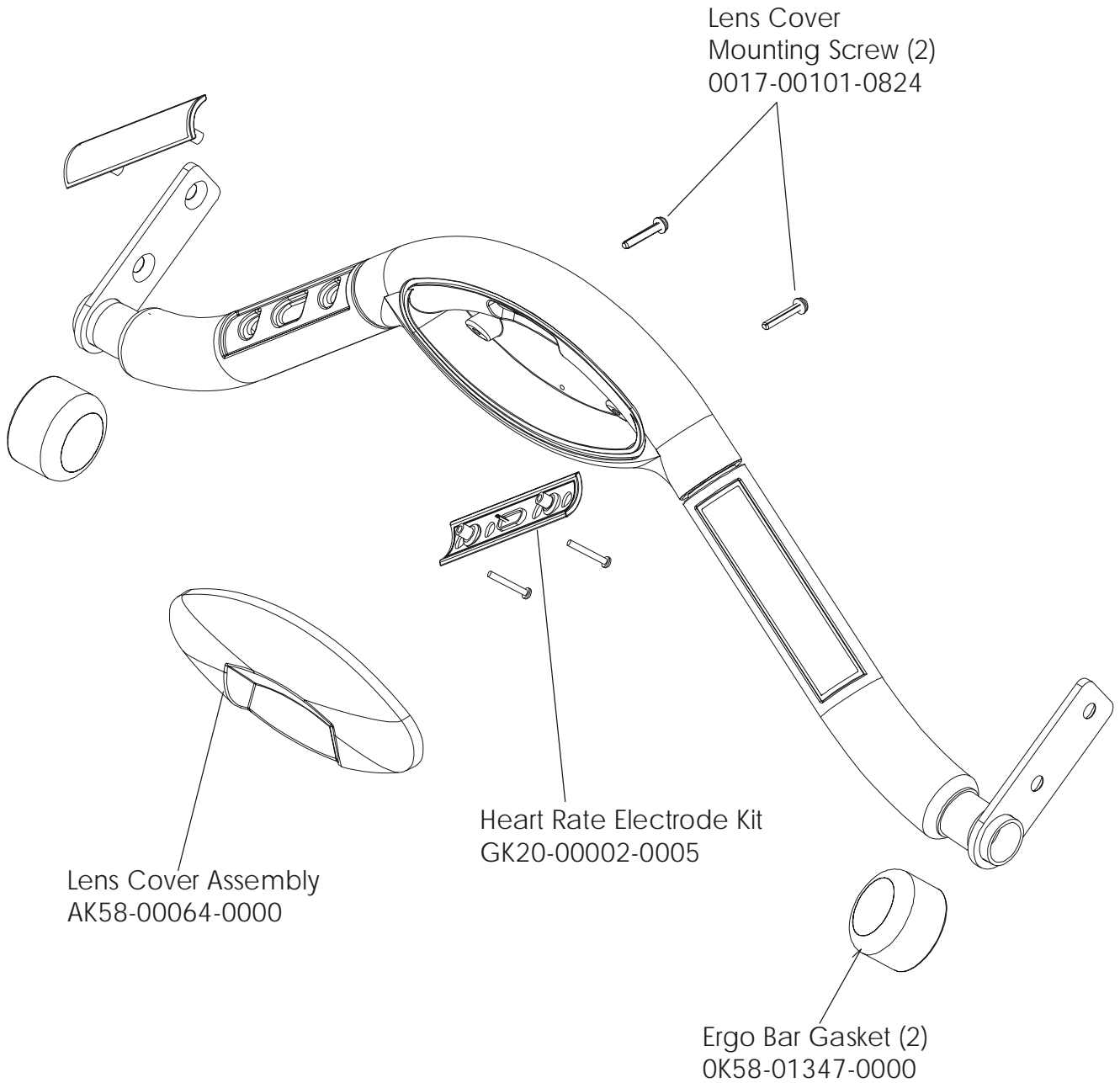

ARCTIC SILVER 95TW

Power Components Schematic 1

95TW-0XXX-03

S/N WTE100000 and up

- Line Cord (Plug End Changes)
 0017-00003-0947 12' 120v
 *0017-00003-0974 Domestic
 0017-00003-0948 12' 220v
 0017-00003-0915 RT Angle Plug
 0017-00003-0781 220v/60Hz
 0017-00003-0696 Continental
 0017-00003-0890 240v/59Hz UK
 0017-00003-0996 240v+ AUS
 * standard cord for domestic unit

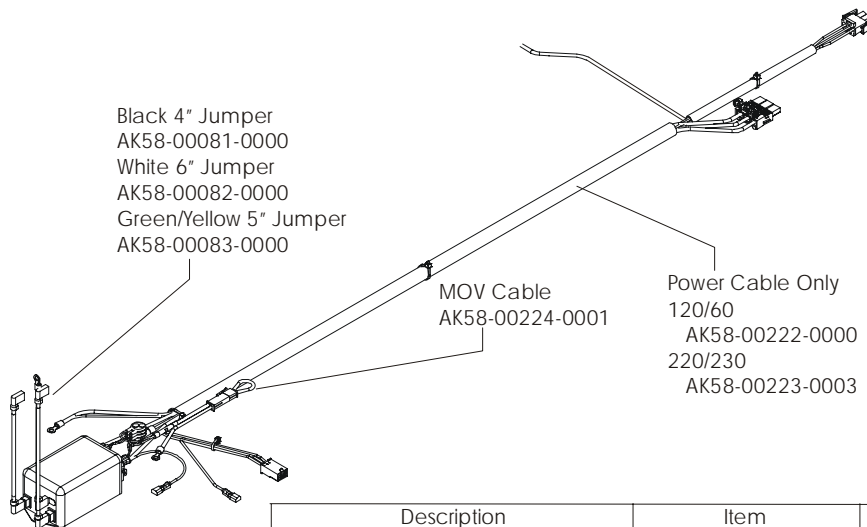
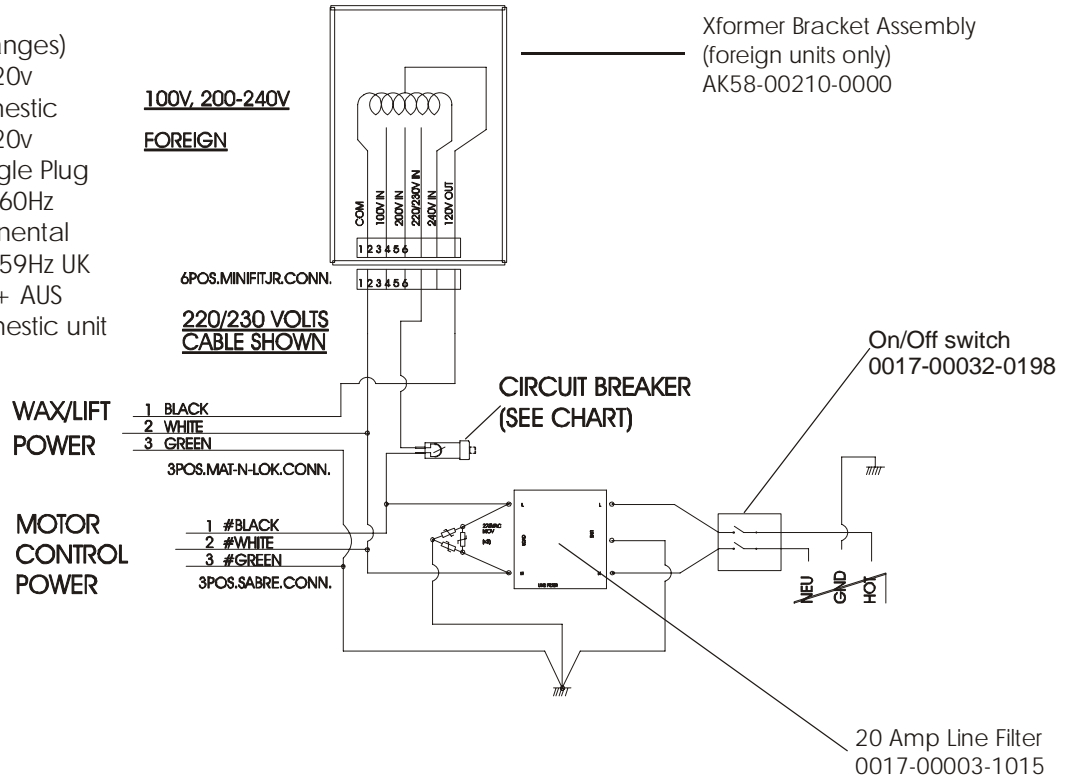

Description	Item	Item	Item
HARNESS-ASSY:MFG;120/60 20A E	0017-00003-1015	AK58-00222-0000	AK32-00265-0001
HARNESS-ASSY:MFG;220/60 20A E	0017-00003-1015	AK58-00223-0003	AK32-00265-0002
HARNESS-ASSY:MFG;230/50 10A E	-	AK58-00223-0003	AK32-00265-0003
HARNESS-ASSY:MFG;240/50 10A E	-	AK58-00223-0004	AK32-00265-0004
HARNESS-ASSY:MFG;240V+ 20A E	0017-00003-1015	AK58-00223-0004	AK32-00265-0005
HARNESS-ASSY:MFG;100/50 20A E	0017-00003-1015	AK58-00223-0001	AK32-00265-0006
HARNESS-ASSY:MFG;200/50 20A E	0017-00003-1015	AK58-00223-0002	AK32-00265-0007

ARCTIC SILVER 95TW

Power Components Schematic 2

95TW-0XXX-03
S/N WTE100000 and up

120V DOMESTIC ONLY

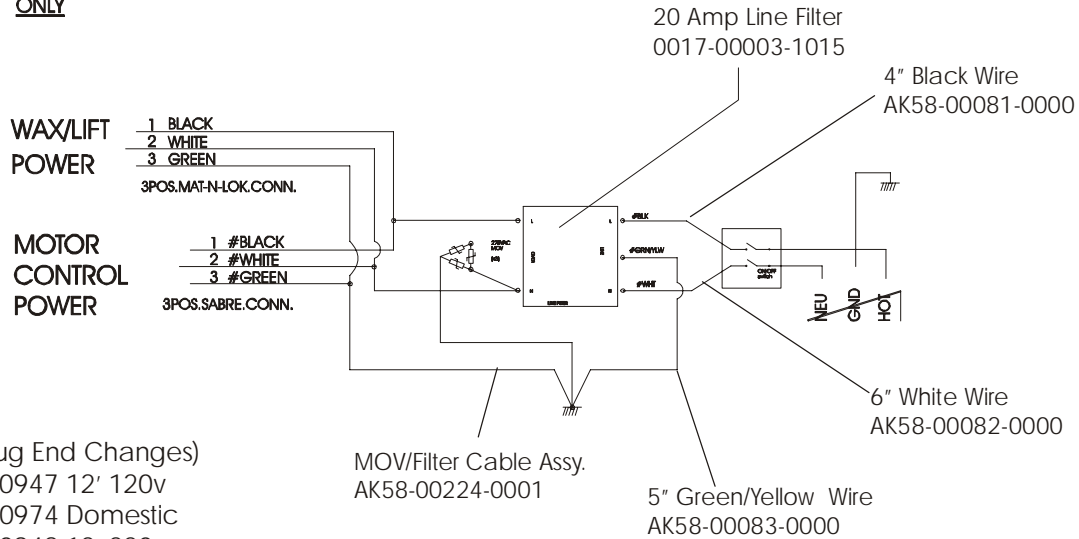

- Line Cord (Plug End Changes)
 0017-00003-0947 12' 120v
 0017-00003-0974 Domestic
 0017-00003-0948 12' 220v
 0017-00003-0915 RT Angle Plug
 0017-00003-0781 220v/60Hz
 0017-00003-0696 Continental
 0017-00003-0890 240v/59Hz UK
 0017-00003-0996 240v+ AUS

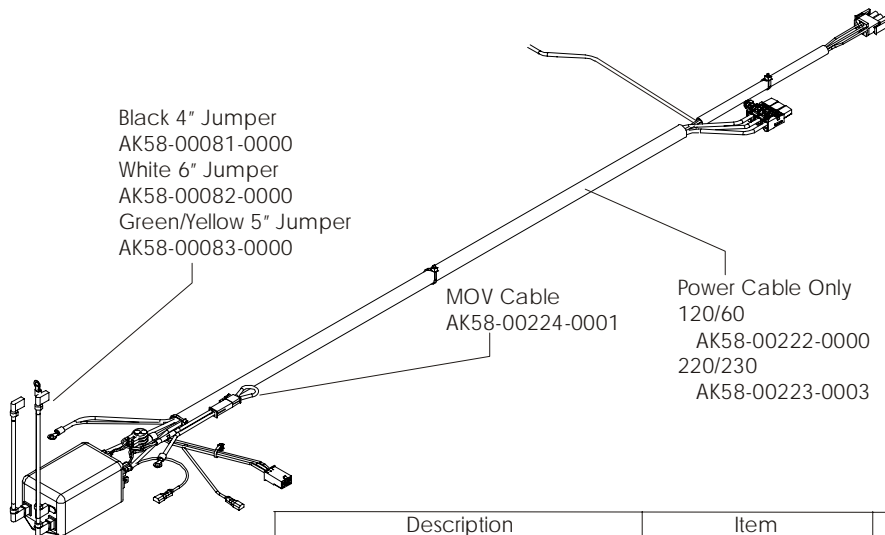

Description	Item	Item	Item
HARNESS-ASSY:MFG;120/60 20A E	0017-00003-1015	AK58-00222-0000	AK32-00265-0001
HARNESS-ASSY:MFG;220/60 20A E	0017-00003-1015	AK58-00223-0003	AK32-00265-0002
HARNESS-ASSY:MFG;230/50 10A E	-	AK58-00223-0003	AK32-00265-0003
HARNESS-ASSY:MFG;240/50 10A E	-	AK58-00223-0004	AK32-00265-0004
HARNESS-ASSY:MFG;240V+ 20A E	0017-00003-1015	AK58-00223-0004	AK32-00265-0005
HARNESS-ASSY:MFG;100/50 20A E	0017-00003-1015	AK58-00223-0001	AK32-00265-0006
HARNESS-ASSY:MFG;200/50 20A E	0017-00003-1015	AK58-00223-0002	AK32-00265-0007

ARCTIC SILVER 95TW
Wax/Lift Power Supply

95TW-0XXX-03
S/N WTE100000 and up

For pre-wired units:
 120" Coax Cable
 AK32-00020-0002
 120" Power Extension Cable
 AK32-00078-0001

