

HealthTrainer®

HT403T

Owner's Manual

HEALTH TRAINER 403T TREADMILL

Customer Service
(888) 340-0482

Keys Fitness Products
4009 Distribution Drive
Suite 250
Garland, TX 75041

www.keysfitness.com

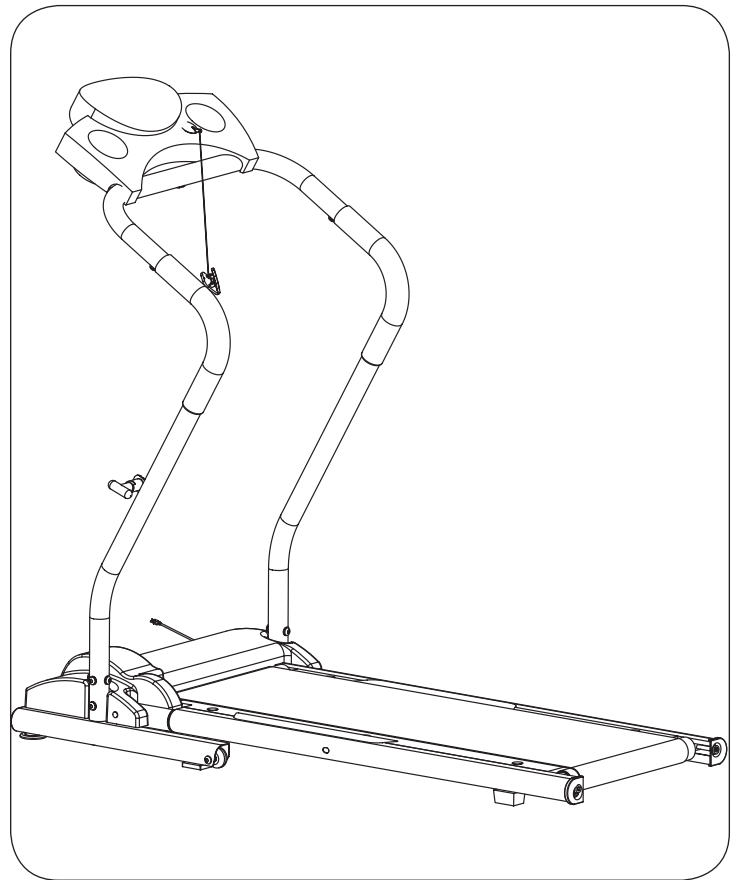

Model Name : HT403T
Serial Number :
Purchase Date :
Write down for future reference
Serial Number Decal Location

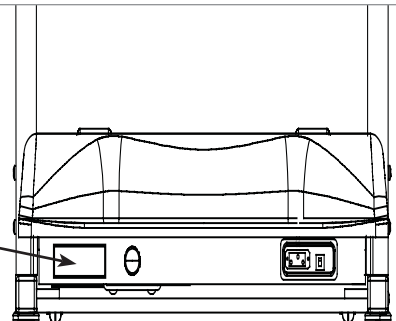

Table of Contents

Important Safety Information	3
Before You Start	4
Assembly	5-7
Warm Up Exercises	8
Moving Instructions	9
Power Requirements	10
Console Panel Functions	11-12
Program and Operation	13-14
Belt Adjustment	15
Maintenance Instructions	16
Troubleshooting Guide	17
Error Messages	18
Parts List	19
Exploded View	20
Warranty Information	21

Important Safety Information

WARNING! Before using this treadmill or starting any exercise program, consult your physician. This is especially important for persons over the age of 35 and/or persons with pre-existing health problems. The manufacturer or distributor assumes no responsibility for personal injury or property damage sustained by or through the use of this product.

WARNING! To reduce the risk of electrical shock, burns, fire, or other possible injuries to the user, it is important to review this manual and the following precautions **before** operation.

SAVE THESE INSTRUCTIONS

SAFETY PRECAUTIONS AND TIPS

1. Always secure Safety Key firmly to waistband.
2. It is the owner's responsibility to ensure that all users of this treadmill have read the Owner's Manual and are familiar with warnings and safety precautions.
3. This treadmill has a user maximum capacity of **225** pounds.
4. The treadmill should only be used on a level surface and is intended for indoor use only. The treadmill should not be placed in a garage, patio, or near water and should never be used while you are wet. Keys recommends a treadmill mat be placed under the treadmill to protect floor or carpet and for easier cleaning.
5. Follow safety information in regard to plugging in your treadmill. Keep the power cord away from the incline wheels and do not run the power cord underneath your treadmill. Do not operate the treadmill with a damaged or frayed power cord.
6. Wear comfortable, good-quality walking or running shoes and appropriate clothing. Do not use the treadmill with bare feet, sandals, socks or stockings.
7. Always straddle the belt and allow it to start moving before stepping onto the belt.
8. Hold on to handrail when adjusting speed or other controls.
9. Always examine your treadmill before using to ensure all parts are in working order.
10. Allow the belt to fully stop before dismounting.
11. Pets should never be allowed near or on the treadmill.
12. Close supervision is necessary when this appliance is used by or near children, invalids or disabled persons.
13. Never operate the treadmill where oxygen is being administered, or where aerosol products are being used.
14. Never insert any object or body parts into any opening.
15. For safety and to prevent damage to your treadmill, no more than one person should use the treadmill at a time.
16. Always unplug the treadmill before cleaning and/or servicing. Service to your treadmill should only be performed by an authorized service representative, unless authorized and/or instructed by the manufacturer
17. Failure to follow these instructions will void the treadmill warranty.
18. Never leave the treadmill unattended when plugged in. Unplug from outlet when not in use and before service or maintenance.
19. Always unplug this appliance immediately after using and before cleaning. To disconnect, turn all controls to the off position, then remove plug from outlet.

Before You Start

Thank you for purchasing the **HEALTH TRAINER 403T Treadmill!** This quality product you have chosen was designed to meet your needs for cardiovascular exercise. Before you start, please read the Owner's Manual and become familiar with the operation of your new treadmill.

Remember to take the time to perform the stretching exercises provided to avoid injury.

Do not stand on the walking belt while pressing the Power button or Start/Stop button.

Always adjust the speed of the treadmill in small increments as this treadmill is capable of high speeds.

If you are taking medication, consult your physician to see if the medication will affect your exercise heart rate.

If you have heart problems, you are not active, and/or are over the age of 35 years, do not use the pre-set treadmill programs or start an exercise program without first contacting and receiving approval from your physician.

To avoid the risk of electrical shock, always keep the console dry. Do not spill liquids on the console. Keys Fitness recommends a sealed water bottle for beverages consumed while using the treadmill.

Please review the following drawing below to familiarize yourself with the listed parts.

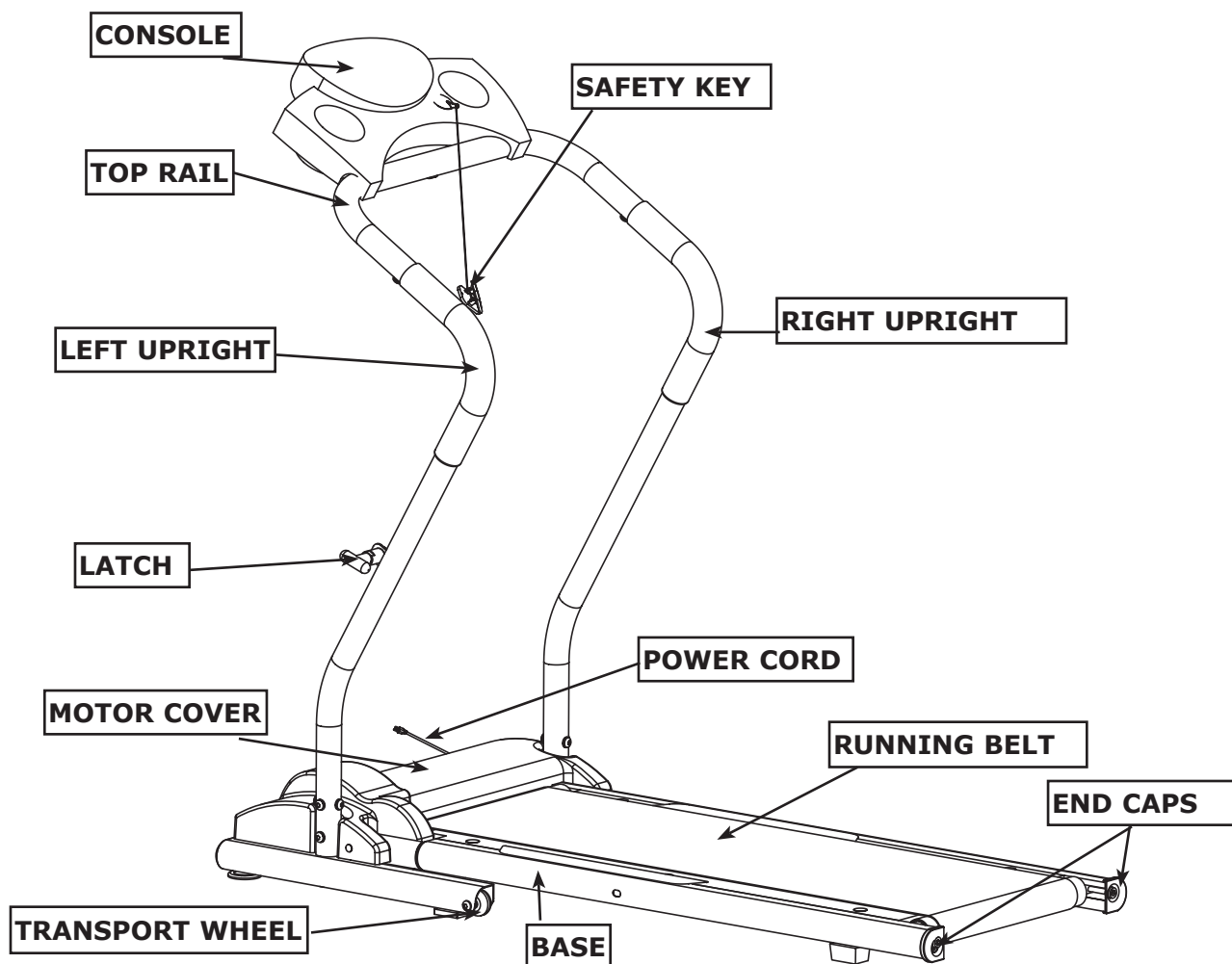

Assembly

The HEALTH TRAINER 403t treadmill will require assembly before operating. After opening the box, remove any packing material from the treadmill.

Do not throw away any packing materials until the unit is working properly.

Place the base on a clean, level surface. Make sure the electrical cord will easily reach an electrical outlet.

Locate the hardware pack and identify the following parts required for assembly.

Assembly Parts:

1. Owner's Manual
2. Console Assembly
3. Left and Right Uprights
4. Top Rail
5. Allen Wrench
6. Arc Washer 10*20*1.5 mm (10)
7. Allen Bolt M8*15 mm (10)
8. Allen Bolts M5*15 mm (4)

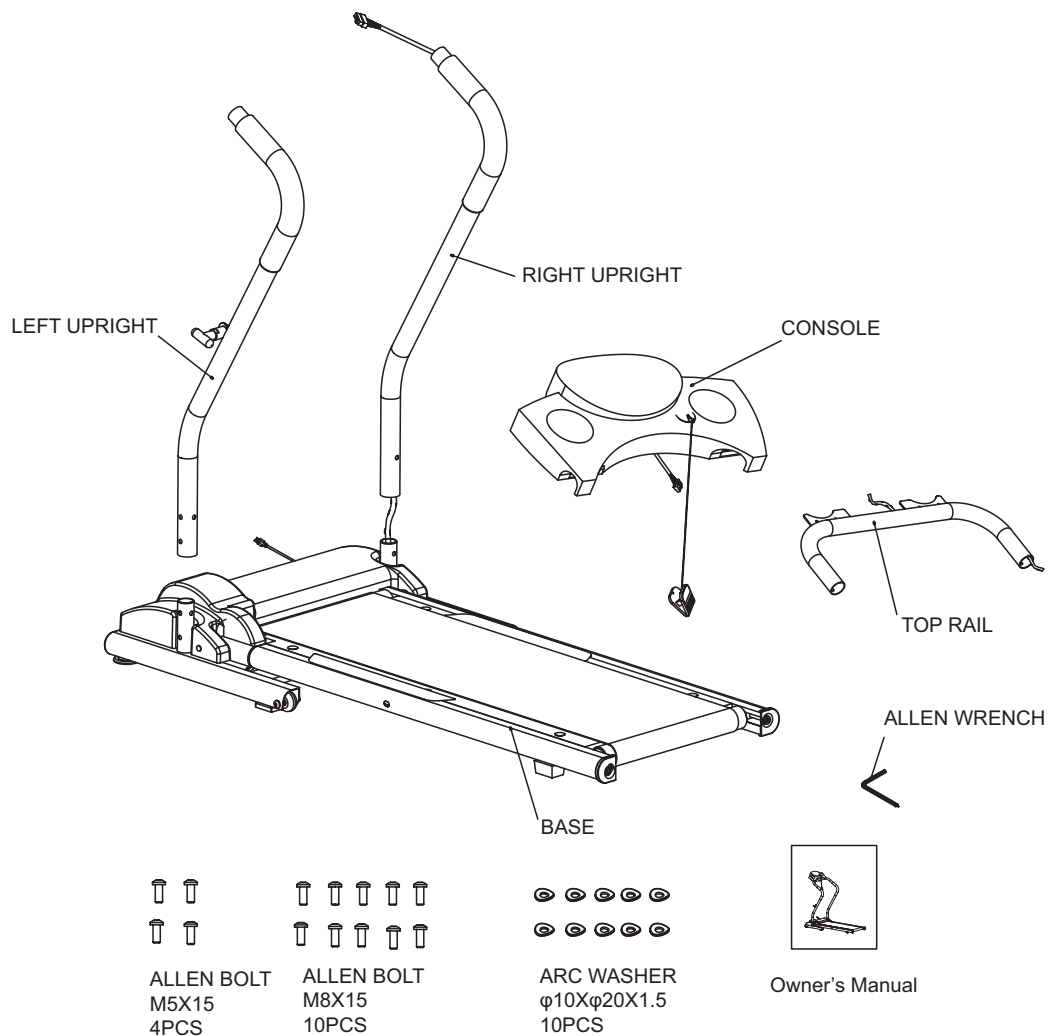

Assembly

Assembly requires the included Allen wrench and your own Phillips screwdriver.

Do not plug in the power cord until all assembly steps are completed.

1. With the treadmill deck in the down position, leave the unit on the original packing material to assemble all parts. Refer to Figure 1.

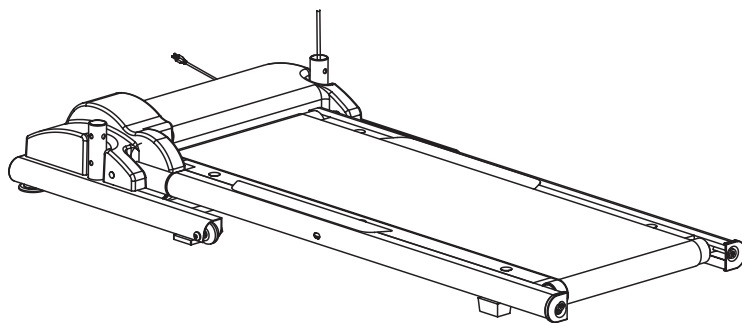

Figure 1: Deck in Down Position

2. Install Left Upright to base using four Allen Bolts M8*15mm (#27) and four Arc Washers (#41). Hand tighten all hardware at this time.

Repeat for Right Upright . Refer to Figure 2.
Note: Be careful not to pinch the wire harness.

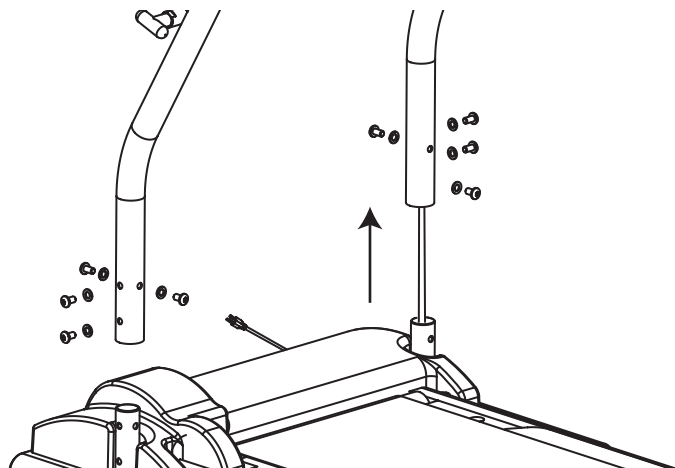

Figure 2: Left and Right Upright Installation

3. Use the drag line to pull Console Wire Harness thru the top rail as shown in Figure 3. Place the grommet over the Console Wire Harness and install the grommet in the top rail.

Note: Be careful not to pinch the wire harness.

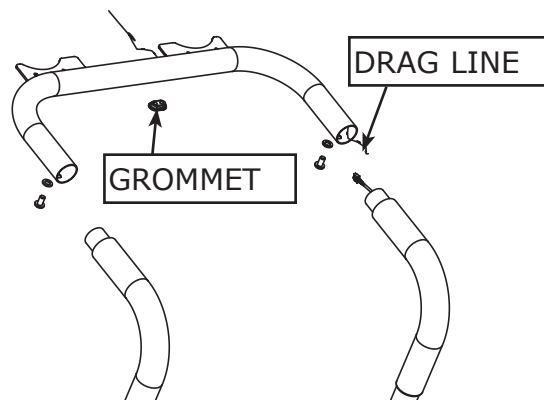

Figure 3: Top Rail Grommet Assembly

Assembly

4. Attach the top rail to the left and right uprights using two Allen Bolts M5*15 (# 26) and two Arc Washers (#41).

You may now firmly tighten all hardware. Refer to Figure 4.

Note: Be careful not to pinch the wire harness.

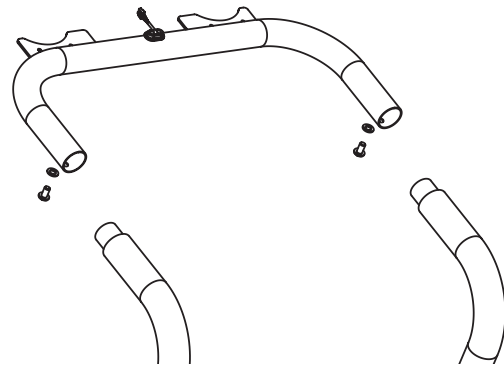

Figure 4: Top Rail Assembly

5. Remove the four M5*20mm screws from the back of the console. Set aside.

Connect Console Wire Harness being careful not to pinch the wires.

Using four screws previously removed from console, attach console to the Top Rail. Refer to Figure 5.

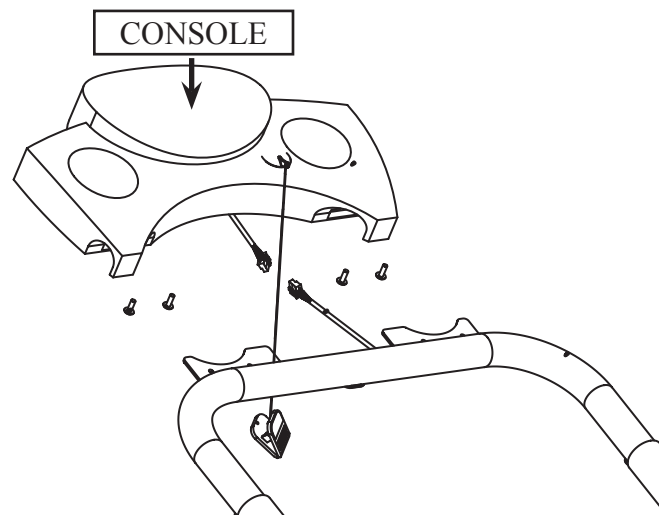
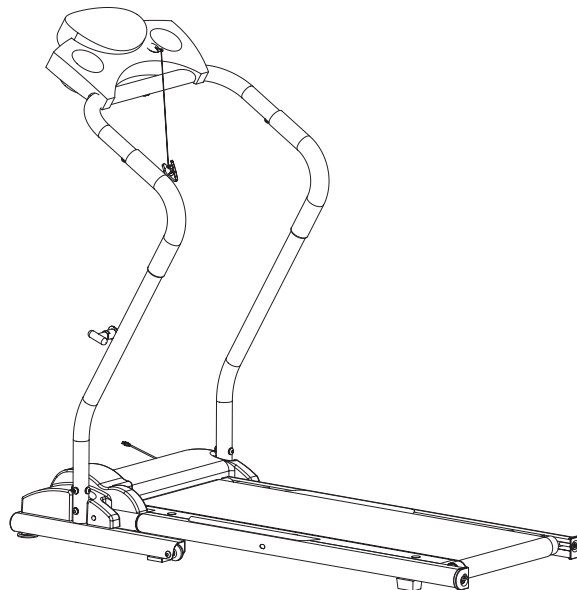

Figure 5: Console Wire Connections

CONGRATULATIONS!!!!!!!

You have completed the assembly of your HealthTrainer 403T Treadmill.



Warm Up Exercises

EXERCISE GUIDELINES

WARNING! Before beginning this or any exercise program, you should consult your physician. This is especially important for individuals over the age of 35 or individuals with pre-existing health problems.

Warming up prepares the body for the exercise by increasing circulation, supplying more oxygen to the muscles and raising body temperature. Begin each workout with 5 to 10 minutes of stretching and light exercise to warm up. The photos on this page show several forms of basic stretching you may perform before your workouts. In order to achieve an adequate warm-up, perform each stretch three times.

TOE TOUCH STRETCH

Stand bending your knees slightly and slowly bend forward from your hips. Allow your back and shoulders to relax as you reach down toward your toes as far as possible. Hold for 15 counts, then relax. This will stretch your hamstrings, back of knees, and back.



HAMSTRING STRETCH

Sit with one leg extended. Bring the sole of the opposite foot toward you and rest it against the inner thigh of your extended leg. Reach toward your toes as far as possible. Hold for 15 counts, then relax. This will stretch your hamstrings, lower back, and groin.



CALF/ACHILLES STRETCH

With one leg in front of the other, reach forward and place your hands against a wall. Keep your back leg straight and your back foot flat on the floor. Bend your front leg, lean forward and move your hips toward the wall. Hold for 15 counts, then relax. To cause further stretching of the Achilles tendon, bend your back leg as well. This will stretch your calves, Achilles tendons, and ankles.

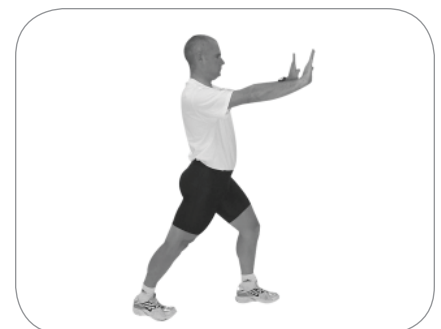

QUADRICEPS STRETCH

With one hand against a wall for balance, reach back and grasp one foot with your other hand. Bring your heel as close to your buttocks as possible. Hold for 15 counts, then relax. This will stretch your quadriceps and hip muscles.

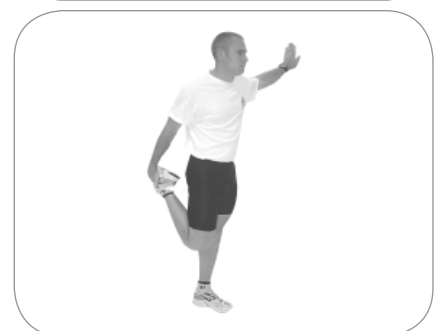

INNER THIGH STRETCH (Image Not Shown)

Sit with the soles of your feet together and your knees outward. Pull your feet toward your groin area as far as possible. Hold for 15 counts, then relax. This will stretch your quadriceps and hip muscles.

Moving Instructions

Caution! To avoid the risk of injury, never attempt to move the treadmill while it is in the unfolded operating position. To reduce the possibility of injury while lifting, bend your legs and keep your back straight. As you raise the treadmill, lift using your legs, not your back. In order to raise or lower the treadmill safely, you must be able to lift 45 pounds (20kg). It is suggested you always use the aid of a second person when moving the treadmill.

With the treadmill in the folded locked position (safety latch is engaged), grasp the handrail and place one foot on the base as shown in the photo below. Next, with a firm grasp on handrail, place one foot on the center of the base crossbar and carefully tilt the treadmill back until it rolls freely on the wheels. Using extreme caution, move the treadmill to the desired location. To set the treadmill down, place one foot on the center of the base crossbar and carefully lower treadmill onto base in resting position. Do not attempt to move the treadmill over an uneven or rough surface.



Note: Picture may not be identical to your unit.

Power Requirements

IMPROPER CONNECTION OF THE EQUIPMENT GROUNDING CONNECTOR CAN RESULT IN A RISK OF AN ELECTRIC SHOCK. CHECK WITH A QUALIFIED ELECTRICIAN OR SERVICE MAN IF YOU ARE IN DOUBT AS TO WHETHER THE PRODUCT IS PROPERLY GROUNDED. DO NOT MODIFY THE PLUG PROVIDED WITH THE PRODUCT IF IT WILL NOT FIT THE OUTLET HAVE A PROPER OUTLET INSTALLED BY A QUALIFIED ELECTRICIAN.

This treadmill can be seriously damaged by sudden voltage changes in your home's electrical power. Voltage spikes, surges, and noise interference can result from weather conditions or from other appliances being turned on or off. To reduce the possibility of treadmill damage, always use a surge protector (not included) with your treadmill.

Surge protectors can be purchased at most hardware stores. The manufacturer recommends a single outlet surge protector with UL 1449 rating as a Transient Voltage Surge Suppressor (TVSS) with UL suppressed voltage rating of 400V or less and an electrical rating of 120VAC, 15 amps.

This treadmill must be grounded to reduce the risk of electrical shock. Grounding provides a path of least resistance for electric current should the treadmill malfunction. This treadmill comes with an electrical cord with an equipment-grounding conductor and a grounding plug. Always plug the power cord into a surge protector, and plug the surge protector into an appropriate outlet that is properly installed and grounded in accordance with all local codes and ordinances.

This product is for use on a nominal 120-volt circuit and has a grounding plug that looks like the plug illustrated in the drawing below.

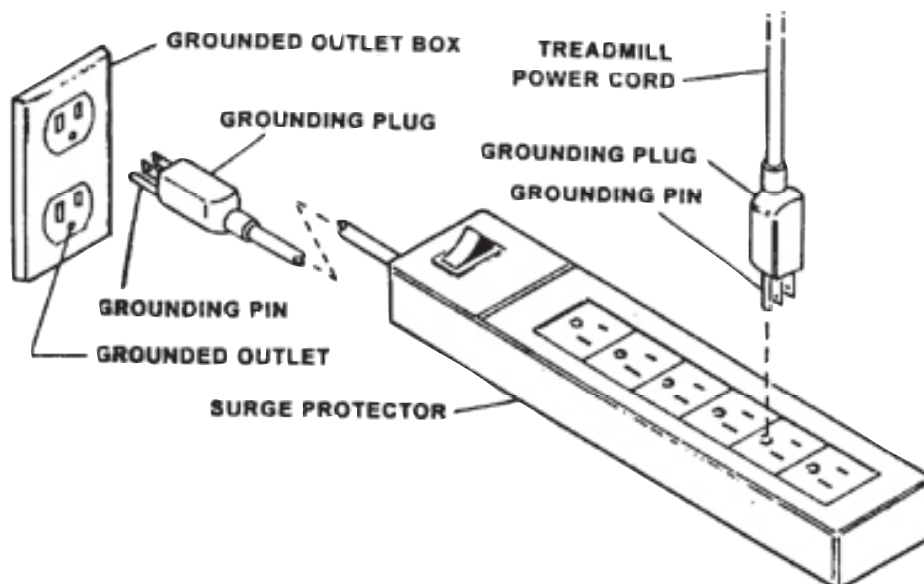

Console Overview

CONSOLE FUNCTIONS

There is one display windows on the control panel to provide feedback information. This window will display information on the following functions:

TIME Indicates elapsed time after pressing start in minutes and seconds (0-99 minutes, 0-59 seconds).

SPEED Indicates MPH (miles per hour) in .1 increments.

DISTANCE: Indicates Miles .01 increments up to 99.99.

CALORIES Indicates calories burned from 0 up to 999.



Console Overview

CONSOLE BUTTONS

There are 8 Console button.

POWER: Used to turn unit off and on.

START: Used to start unit.

STOP: Used to stop unit.

RESET: Used to reset values in display window.

PROGRAM: Used to toggle thru five preset programs.

MODE: Used to toggle thru different modes.

SPEED +/-: Used to increase and decrease speed. Also used to scroll through modes.



Program and Operation

MODE OVERVIEW

This treadmill has 5 different exercise modes. Following is a brief overview and instruction for each mode.

MANUAL MODE: Allows user to manually adjust Speed with + or - button. Time, Calories and Distance count up from 0.

To use Manual Mode, Attach safety key. Press Start button. You are now in Manual Mode. You may adjust the speed of the treadmill using the + or - button. Press Stop to end workout.

TIME CONTROL MODE: Allows user to set Time of exercise session. Time will countdown from value you set. Calories and Distance will count up from 0.

To use Time Control Mode, Attach safety key. Press Power button. Press Up (+) button. You are now in Time Control Mode. The Time display will default to 8:00 (mm:ss). You may use the + or - button to adjust the Time for your exercise session. Press Start button to begin your workout. During your workout you may use the + or - button to adjust your Speed.

DISTANCE CONTROL MODE: Allows user to set Distance of exercise session. Distance will countdown from the value you set. Time and Calories will count up from 0.

To use Distance Control Mode, Attach safety key. Press Power Button. Press MODE button. You are now in Distance Control Mode. The Distance will default to 1.0 miles. Use the + or - button to set desired distance for your exercise session. Press Start button to begin your workout. During your workout you may use the + or - button to adjust your Speed.

CALORIE CONTROL MODE: Allows user to set Calories they would like to burn during workout session. Calories will countdown from value you set. Time and Distance will count up from 0.

To use Calorie Control Mode, Attach Safety Key. Press Power button. Press Mode button **twice**. You are now in Calorie Control Mode. The Calories will default to 10. Use the + or - button to set desired calories burned for your exercise session. Press the Start button to begin your workout. During your workout you may use the + or - button to adjust your speed.

Program and Operation

PROGRAM MODE: Allows users to select a preset program. There are 5 preset programs available. Preset Programs are divided into twenty time segments. Speed changes after each segment. Refer to chart for Speed profiles for preset programs. To use Program Mode, attach Safety Key. Press Power button. Use the Program button to scroll thru programs 1-5. Time default on all preset programs is 30:00. Use the + or - button to set desired time for your exercise session. Press Start to begin your workout.

	SPEED (mile/hr)				
	P1	P2	P3	P4	P5
Segment 1	0.6	0.6	0.6	0.6	0.6
Segment 2	0.6	1.2	1.2	0.6	1.2
Segment 3	1.2	1.8	1.8	1.2	1.8
Segment 4	1.8	3.0	2.4	1.2	3.0
Segment 5	1.8	3.6	3.0	1.8	3.6
Segment 6	2.4	4.2	3.6	1.8	4.8
Segment 7	3.0	3.6	4.2	2.4	3.6
Segment 8	3.6	2.4	4.8	2.4	4.8
Segment 9	3.6	1.2	5.4	3.0	3.6
Segment 10	4.2	0.6	4.8	3.0	4.8
Segment 11	4.8	0.6	5.4	3.6	3.6
Segment 12	4.2	1.2	4.8	3.6	4.8
Segment 13	3.6	1.8	4.2	4.2	3.6
Segment 14	4.2	3.0	3.6	4.2	4.8
Segment 15	4.8	3.6	3.0	4.8	3.6
Segment 16	3.6	4.2	2.4	4.8	3.0
Segment 17	3.0	3.6	1.8	5.4	2.4
Segment 18	1.8	2.4	1.2	3.0	1.9
Segment 19	1.2	1.2	0.6	1.2	1.8
Segment 20	0.6	0.6	0.6	0.6	0.6

Belt Adjustment

WARNING! Do not over-tighten rollers! This will cause premature roller bearing failure!

Belt adjustment and tension performs two functions: adjustment for tension and centering. Your new treadmill comes pre-adjusted from the factory for tension and centering. Please follow the procedures below if the belt shifts to the left or right while walking:

WALKING BELT SHIFTING TO THE LEFT (Diagram 1)

First, turn treadmill on to run at 1 mph. Using the hex key provided, turn the left rear roller adjustment bolt $\frac{1}{4}$ turn in the clockwise direction. Next, run the treadmill at 2.5 mph. You should see the belt start to correct itself by moving back towards the center. Repeat the above procedure until the walking belt is centered. It may be necessary to set walking belt tension once you have completed this procedure if the belt feels like it is slipping while walking. Refer below to the "Walking Belt Slipping" instructions.

WALKING BELT SHIFTING TO THE RIGHT (Diagram 2)

First, turn the treadmill on to run at 1 mph. Using the hex key provided, turn the right rear roller adjustment bolt $\frac{1}{4}$ turn in the clockwise direction. Next, run the treadmill at 2.5 mph. You should see the belt start to correct itself, moving back towards the center. Repeat the above procedure until the walking belt is centered. It may be necessary to set walking belt tension once you have completed this procedure if the belt feels like it is slipping while walking. Refer below to the "Walking Belt Slipping" instructions.

WALKING BELT IS SLIPPING DURING USE (Diagram 3)

First, unplug the power cord from the surge protector. Using the hex key provided, turn both left and right rear roller adjustment bolts the same distance, usually a $\frac{1}{4}$ turn in the clockwise direction. Plug the power cord back into the surge protector and run the treadmill at 2.5 mph. You should now walk on the belt to determine if the belt is still slipping. Repeat the above procedure until the walking belt is not slipping. The tension should be just tight enough not to slip.

Note: Turning the hex key clockwise brings the rear rollers and belt towards you.

Turning the hex key counter clockwise pushes the rear roller and belt away from you.



Diagram 1



Diagram 2



Diagram 3

Maintenance Instructions

WARNING! Before performing any maintenance to your treadmill, always unplug the power cord from the surge protector.

CLEANING

Routine cleaning of your HT403T Fitness treadmill will extend the life of your treadmill.

WARNING! To prevent electrical shock, be sure the power to the treadmill is OFF and the unit unplugged from the wall electrical outlet before attempting any cleaning or maintenance.

AFTER EACH WORKOUT: Wipe off the console and other treadmill surfaces with a clean, water dampened soft cloth to remove excess perspiration. USE NO CHEMICALS.

WEEKLY: Use of a treadmill mat is recommended for ease of cleaning. Dirt from your shoes contacts the belt and eventually makes it to underneath the treadmill. Vacuum underneath treadmill once a week.

DECK LUBRICATION

The walking belt has been pre-lubricated at the factory. However, it is recommended that the walking board be checked periodically for lubrication to ensure optimal treadmill performance. Every 30 days or 30 hours of operation, lift the sides of the walking belt and feel the top surface of the walking board as far under as you can reach. If you feel signs of silicone, no further lubrication is required. If it feels dry to the touch, follow the instructions below.

Keys Fitness recommends "Lube N Walk" for cleaning and lubricating the treadmill belt and deck. Ask your retailer or call Keys Fitness at 888-340-0482. You may also use silicone such as "Napa 8300" (available at most NAPA Auto Parts stores).

TO APPLY LUBRICANT TO THE WALKING BOARD

- 1) Position the walking belt so that the seam is located on top and in the center of the center of the walking board.
- 2) Insert the spray nozzle into the spray head of the lubricant can.
- 3) While lifting the side of the walking belt, position the spray nozzle between the walking belt and the board approximately 6" from the front of the treadmill. Apply the silicone spray to the walking board, moving from the front of the treadmill to the rear. Repeat this on the other side of the belt. Spray approximately 4 seconds on each side.
- 4) Allow the silicone to 'set' for one minute before using the treadmill.

WARNING: Do not over-lubricate the walking board. Excess lubricant should be wiped off with a clean towel.

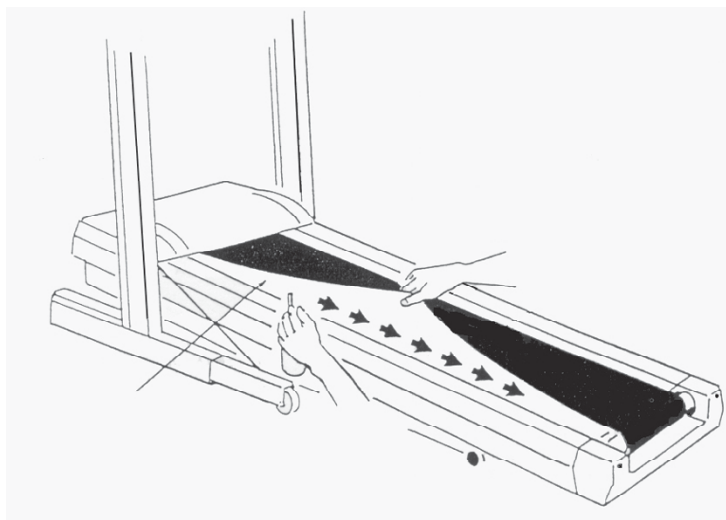

Troubleshooting Guide

Treadmill will not start.

1. Is the **Safety Key** inserted into the treadmill Console?
2. Make sure the power cord is plugged into a surge protector, the surge protector is plugged into a properly grounded outlet, and the surge protector is turned on. (Refer to "Power Requirements" on page 11).
3. Check the circuit breaker located on the front of the treadmill. If the switch protrudes, it has tripped. Wait five minutes and then press the switch back in.
4. Check the house electrical breaker box and the circuit breaker for the room where the treadmill is located. If it has tripped, reset or have an electrician replace the breaker in home.
5. Have an electrician check for inadequate voltage at the outlet.

Treadmill loses power during use.

1. Check the circuit breaker located on the front of the treadmill. If the switch protrudes, it has tripped. Wait five minutes and then press the switch back in.
2. Check the house electrical breaker box and the circuit breaker for the room where the treadmill is located. If it has tripped, reset or have an electrician replace the breaker in home.
3. If the treadmill still will not operate, please call Keys Customer Service at (888) 340-0482.

Treadmill walking belt slows during use.

1. Check to make sure the treadmill is securely plugged into an UL-listed surge protector, rated at 15 amps, with a 14-gauge cord of five feet or less and the surge protector is securely plugged into the outlet.
2. If treadmill still will not operate, please call Keys Customer Service at (888) 340-0482.

Treadmill walking belt slips or is not centered on rear roller.

1. Refer to "Belt Adjustment and Tension" section on page 15.
2. Need help? Call Keys Customer Service at (888) 340-0482.

Treadmill Error Messages.

Your treadmill is equipped with a software package that enables error messages to be displayed when there is a problem.

To avoid possible damage to the treadmill and the possibility of injury, do not operate the treadmill until the problem is corrected. Call Keys Customer Service at (888) 340-0482. Or, see "Error Messages" on page 18 of this Owners Manual.

Error Messages

Treadmill Error Messages

Your treadmill is equipped with a software package that enables error messages to be displayed when there is a problem. The following error codes will be displayed in the console display windows.

Error Messages

Er-1 - The console to motor controller communication is not complete. Check signal cable connections.

Er-2 - The motor control board and motor are disconnected. Check motor cable connections at motor controller.

Er-3 - The motor controller is not receiving a signal from the speed sensor. Check the connection between the speed sensor and the motor controller.

Er-7 - Safety Key missing, replace and try again.

To avoid possible damage to the treadmill and the possibility of injury, do not operate the treadmill until the problem is corrected. Call Keys Customer Service at (888) 340-0482.

Parts List

HT403T Parts List Rev A

Ref #	Part #	Description	Qty	Ref #	Part #	Description	Qty
1	423-00046	TOP RAIL, HT403T	1	33	402-00031	PHILIP SCREW ST4.2*13	4
2	423-00045	LEFT UPRIGHT, HT403T	1	34	402-00019	PHILIP SCREW ST4.2*13	2
3	423-00044	RIGHT UPRIGHT, HT403T	1	35	402-00016	PHILIP SCREW ST4.2*13	10
4	423-00047	BASE FRAME, HT403T	1	36	402-00133	ASSEMBLED BOLT, M8X15	2
5	423-00031	LEFT DECK FRAME, HT402T/HT403T	1	37	402-00131	NYLON LOCK NUT, M6	6
6	423-00032	RIGHT DECK FRAME, HT402T/HT403T	1	38	402-00021	NYLON LOCK NUT M8	4
7	406-00136	MOTOR COVER, HT403T	1	39	402-00108	JAM NUT M8	4
8	403-00006	WALK BOARD, HT402T/HT403T	1	40	402-00134	WASHER 6*16*1.6 MM	6
9	404-00010	POLY V-BELT, 180J6, HT402T/HT403T	1	41	402-00132	ARC WASHER, 10X20X1.5	10
10	404-00009	RUNNING BELT, 13*37, HT402T/HT403T	1	42	410-00038	DECK BOARD PASTER 20	6
11	410-00039	FOAM, HT402T/HT403T	2	43	402-00129	PHILLIP SCREW, M5*10	2
12	409-00011	FRONT ROLLER, 1.8", HT402T/HT403T	1	44	402-00037	SCREW ST2.9*9.5	2
13	409-00012	REAR ROLLER, 1.8", HT402T/HT403T	1	45	402-00034	ALLEN WRENCH 110*75*6	1
14	406-00102	D STOPPER, HT402T/HT403T	2	46	406-00080	CORD SPACER	2
15	406-00103	LEFT END CAP, HT402T/HT403T	1	47	406-00098	GROMMET IRONMAN UPRIGHT	1
16	406-00104	RIGHT END CAP, HT402T/HT403T	1	48	402-00031	PHILIP SCREW ST4.2*13	2
17	406-00105	BOTTOM SHEET,13*37, PLASTIC TAB	1	49	402-00023	NYLON LOCK NUT M10	2
18	410-00040	LATCH SET, HT402T/HT403T	1	50	424-00022	CONSOLE ASSEMBLY, HT403T	1
19	414-00105	PVC STRAP, HT403T	2	51	407-00102	MOTOR CONTROLLER, TM5948PSO, HT403T	1
20	406-00106	SENSOR PLATE, HT402T/HT403T	1	52	413-00028	CONSOLE HARNESS, HT402T/HT403T	1
21	406-00107	MOTOR MOUNTING PLATE, HT402T/HT403T	1	53	413-00029	EXTENSION WIRE HARNESS, HT402T/HT403T	1
22	419-00017	BELT GUIDE BRACKET	2	54	413-00030	ENCODER WIRE HARNESS, HT402T/HT403T	1
24	406-00034	TRANSPORT WHEEL	2	55	408-00015	CIRCUIT BREAKER IN-011	1
25	406-00045	ADJUST SUPPORT	2	56	413-00004	POWER CORD	1
26	402-00011	ALLEN BOLT M8*15	12	57	412-00014	MOTOR, C8APB1, HT402T/HT403T	1
27	402-00127	ALLEN BOLT, M8X30	2	58	408-00025	TRANSFORMER, HT402T/HT403T	1
28	402-00128	ALLEN BOLT, M8*55	2	59	408-00026	FERRITE, HT402T/HT403T	1
29	402-00114	SHOULDER ALLEN BOLT M8*60	2	60	406-00134	BASE BUMPER, HT402T/HT403T	2
30	402-00018	PHILIP SCREW M6*12	4	61	411-00005	MOTOR FLYWHEEL, HT402T/HT403T	1
31	402-00130	CHAMBER BOLT, M6X30	6	62	402-00154	SCREW, PHILIP M4*10	1
32	402-00015	PHILIP SCREW ST4.2*16	12	#	415-00056	OWNERS MANUAL HT403T	1

Exploded View

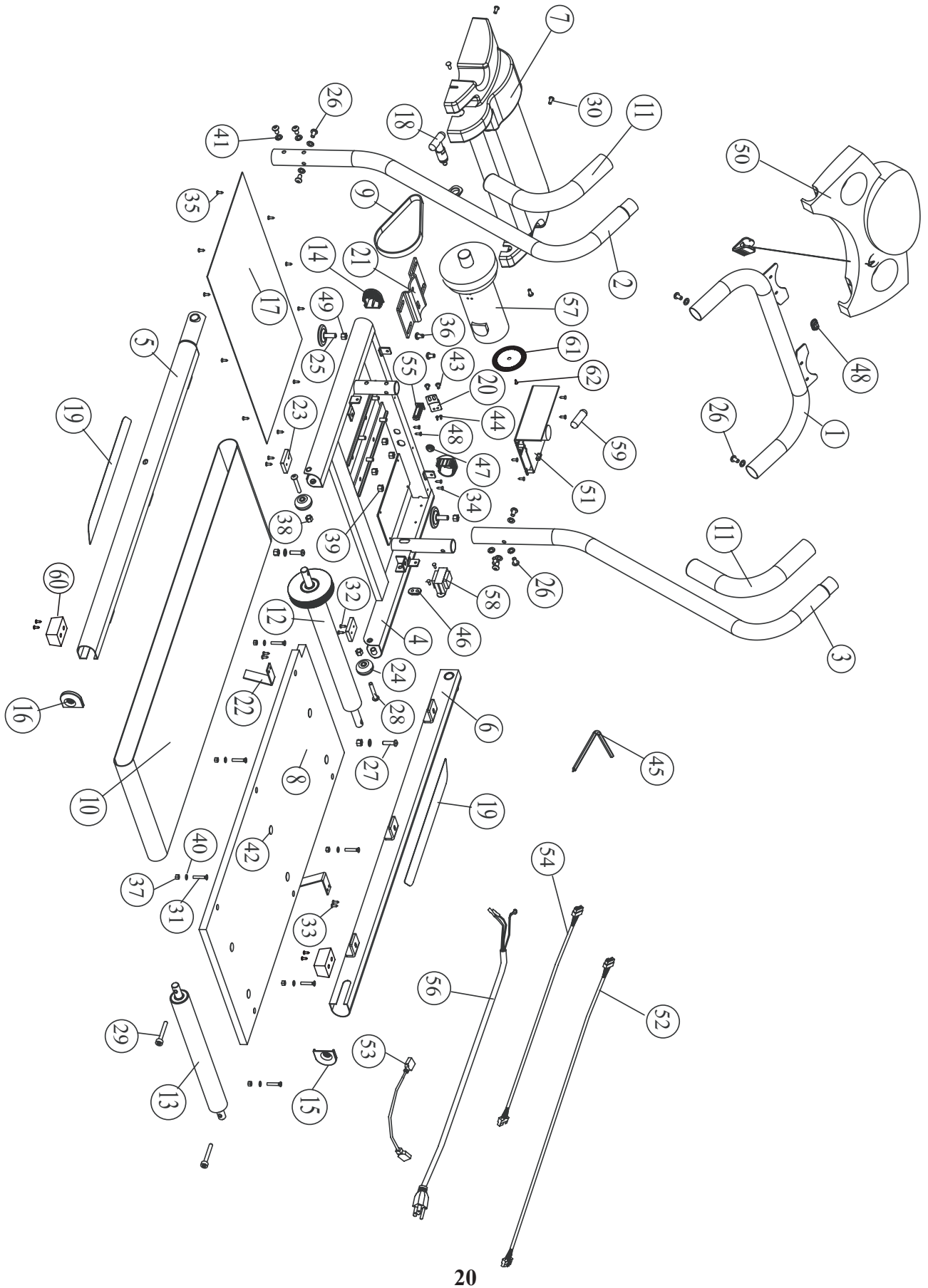

Warranty Information

**HT403T Treadmill designed and distributed by KEYS FITNESS PRODUCTS, LP – LIMITED WARRANTY
PLEASE CONSULT YOUR PHYSICIAN BEFORE USING THIS PRODUCT.**

This Limited Warranty applies in the United States and Canada to products manufactured or distributed by Keys Fitness Products, LP (“Keys”) under the KEYS brand name. The warranty period on the HT403T to the original purchaser is (Lifetime) on the frame, (1) year on the motor and (6) months parts which includes walking deck and belt, No labor warranty.

Keys warrants that the Product you have purchased for non-commercial, personal, family, or household use from Keys or from an authorized Keys reseller is free from defects in materials or workmanship under normal use during the warranty period. Your sales receipt, showing the date of purchase of the Product, is your proof of the date of purchase. This warranty only extends to you, the original purchaser. It is not transferable to anyone who subsequently purchases the Product from you. It excludes expendable parts. This Limited Warranty becomes VALID ONLY if the treadmill is assembled/installed by a Keys Fitness authorized dealer/technician unless otherwise authorized by Keys Fitness in writing (if anyone other than a Keys Fitness authorized dealer/technician assembles a Keys Fitness treadmill the warranty will be void unless accompanied by written authorization by Keys Fitness).

During the warranty period Keys will at no additional charge, repair or replace (at Keys’ option) the product if it becomes defective, malfunctions, or otherwise fails to conform with this Limited Warranty under normal non-commercial, personal, family or household use. In repairing the Product, Keys may replace defective parts, or at the option of Keys, serviceable used parts that are equivalent to new parts in performance. All exchanged parts and Products replaced under this warranty will become the property of Keys.

Keys reserves the right to change manufacturers of any part to cover any existing warranty.

To obtain warranty service, you must contact a Keys authorized service technician or Keys Fitness at our phone numbers located in this manual. Any parts determined to be defective must be returned to Keys to obtain warranty service. You must prepay any shipping charges, export taxes, custom duties and taxes, or any other charges associated with transportation of the parts or Product. In addition, you are responsible for insuring any parts or Product shipped or returned. You assume the risk of loss during shipment. You must present Keys with proof-of-purchase documents (including the date of purchase). Any evidence of alteration, erasing or forgery of proof-of-purchase documents will be cause to void this Limited Warranty.

This warranty does not extend to any product not purchased from Keys or from an authorized Keys reseller. This Limited Warranty does not extend to any Product that has been damaged or rendered defective; (a) as a result of accident, misuse, or abuse; (b) by the use of parts not manufactured or sold by Keys; (c) by modification of the Product or normal wear and tear; (d) operation on incorrect power supplies; or (e) as a result of service by anyone other than Keys, or an authorized Keys warranty service provider. Product on which the serial number has been defaced or removed is not eligible for warranty service. Should any Product be submitted for warranty service be found ineligible therefore, an estimate of repair cost will be furnished and the repair will be made if requested by you upon Keys’ receipt of payment or acceptable arrangements for payment.

EXCEPT AS EXPRESSLY SET FORTH IN THIS WARRANTY, KEYS MAKES NO OTHER WARRANTIES, EXPRESSED OR IMPLIED, INCLUDING ANY IMPLIED WARRANTIES OF MERCHANTABILITY AND FITNESS FOR A PARTICULAR PURPOSE. KEYS EXPRESSLY DISCLAIMS ALL WARRANTIES NOT STATED IN THIS LIMITED WARRANTY. ANY IMPLIED WARRANTIES THAT MAY BE IMPOSED BY LAW ARE LIMITED TO THE TERMS OF THIS LIMITED WARRANTY. NEITHER KEYS NOR ANY OF ITS AFFILIATES SHALL BE RESPONSIBLE FOR INCIDENTAL OR CONSEQUENTIAL DAMAGES. SOME STATES DO NOT ALLOW LIMITATIONS ON HOW LONG AN IMPLIED WARRANTY LASTS OR THE EXCLUSION OR LIMITATION OF INCIDENTAL OR CONSEQUENTIAL DAMAGES, SO THE ABOVE LIMITATIONS OR EXCLUSION MAY NOT APPLY TO YOU.

This Limited Warranty gives you specific legal rights and you may also have other rights that may vary from state to state. This is the only express warranty applicable to Keys-branded products. Keys neither assumes nor authorizes anyone to assume for it any other express warranty.

PLEASE SEND IN THE ATTACHED WARRANTY CARD WITHIN TEN (10) DAYS OF PURCHASE TO REGISTER YOUR TREADMILL WITH KEYS FITNESS PRODUCTS, LP. MADE IN THE USA. Thank you for your business! PLEASE MAIL WARRANTY CARD TO: KEYS FITNESS PRODUCTS, PO BOX 551239, DALLAS, TX 75355, OR ONLINE AT WWW.KEYSFITNESS.COM



Customer Service

(888) 340-0482

Keys Fitness Products

4009 Distribution Drive

Suite 250

Garland, TX 75041

www.keysfitness.com