

# Esprit

- by - 



## ET 188

## OWNER'S MANUAL

# ***Table of Contents***

Product Registration.....	2
Important Safety Instructions.....	3
Important Electrical Information.....	4
Important Operation Instructions.....	5
Assembly instructions.....	6
Operation of Your New Treadmill.....	9
General Maintenance.....	12
Service Checklist - Diagnosis Guide.....	15
Manufacturer's Limited Warranty.....	16



**CONGRATULATIONS ON YOUR  
NEW TREADMILL AND WELCOME  
TO THE SPIRIT FAMILY!**

Thank you for your purchase of this quality treadmill from Spirit Manufacturing, Inc. Your new treadmill was manufactured by one of the leading fitness manufacturers in the world and is backed by one of the most comprehensive warranties available. Through your dealer, Spirit will do all we can to make your ownership experience as pleasant as possible for many years to come. The local dealership where you purchased this treadmill is your administrator for all Spirit warranty and service needs. Their responsibility is to provide you with the technical knowledge and service personnel to make your experience more informed and any difficulties easier to remedy.

Please take a moment at this time to record the name of the dealer, their telephone number, and the date of purchase below to make any future, needed contact easy. We appreciate your support and we will always remember that you are the reason that we are in business. Please complete and mail your registration card today and enjoy your new treadmill.

Yours in Health,  
Spirit Manufacturing, Inc.

**Name of Dealer** \_\_\_\_\_  
**Telephone Number of Dealer** \_\_\_\_\_  
**Purchase Date** \_\_\_\_\_

## ***Product Registration***

### **RECORD YOUR SERIAL NUMBER**

Please record the Serial Number of this fitness product in the space provided below.

**Serial Number** \_\_\_\_\_

### **REGISTER YOUR PURCHASE**

The self-addressed product registration card must be completed in full and returned to Spirit Manufacturing, Inc. or register online at: [www.spiritfitness.com/warranty.asp](http://www.spiritfitness.com/warranty.asp)

ET188\_ver.A

# ***Important Safety Instructions***

**WARNING** - Read all instructions before using this appliance.

**DANGER** - To reduce the risk of electric shock disconnect your Spirit treadmill from the electrical outlet prior to cleaning and/or service work.

**WARNING** - To reduce the risk of burns, fire, electric shock, or injury to persons, install the treadmill on a flat level surface with access to a 120-volt, 15-amp grounded outlet.

**DO NOT USE AN EXTENSION CORD UNLESS IT IS 14AWG OR BETTER, WITH ONLY ONE OUTLET ON THE END.** The treadmill should be the only appliance in the circuit in which it is connected. **DO NOT ATTEMPT TO DISABLE THE GROUNDED PLUG BY USING IMPROPER ADAPTERS, OR IN ANY WAY MODIFY THE CORD SET.** A serious shock or fire hazard may result along with computer malfunctions. See Grounding Instructions, page 3.

- | Do not operate treadmill on deeply padded, plush or shag carpet. Damage to both carpet and treadmill may result.
- | Do not block the rear of the treadmill. Provide a minimum of 3 1/2 feet clearance between the rear of the treadmill and any fixed object.
- | Keep children away from the treadmill. There are obvious pinch points and other caution areas that can cause harm.
- | Keep hands away from all moving parts.
- | Never operate the treadmill if it has a damaged cord or plug. If the treadmill is not working properly, call your dealer.
- | Keep the cord away from heated surfaces.
- | Do not operate where aerosol spray products are being used or where oxygen is being administered. Sparks from the motor may ignite a highly gaseous environment.
- | Never drop or insert any object into any openings.
- | Do not use outdoors.
- | To disconnect, turn all controls to the off position, remove tether cord, then remove the plug from the outlet.
- | Do not attempt to use your treadmill for any purpose other than for the purpose it is intended.
- | The pulse sensors are not medical devices. Various factors, including the user's movement, may affect the accuracy of heart rate readings. The pulse sensors are intended only as exercise aids in determining heart rate trends in general.
- | Use handrails provided; they are for your safety.
- | Wear proper shoes. High heels, dress shoes, sandals or bare feet are not suitable for use on your treadmill. Quality athletic shoes are recommended to avoid leg fatigue.

**Remove tether cord after use to prevent unauthorized treadmill operation.  
SAVE THESE INSTRUCTIONS - THINK SAFETY!**

# Important Electrical Information

## WARNING!

- | **NEVER** use a ground fault circuit interrupt (GFCI) wall outlet with this treadmill. Large switching currents of the drive motor will trip GFCI type outlets, as any appliance with a large motor will. Route the power cord away from any moving part of the treadmill including the elevation mechanism and transport wheels.
- | **NEVER** remove any cover without first disconnecting AC power.
- | If voltage varies by ten percent (10%) or more, the performance of your treadmill may be affected. **Such conditions are not covered under your warranty.** If you suspect the voltage is low, contact your local power company or a licensed electrician for proper testing.
- | **NEVER** expose this treadmill to rain or moisture. This product is **NOT** designed for use outdoors, near a pool or spa, or in any other high humidity environment. The operating temperature specification is 40 to 120 degrees Fahrenheit and humidity limit is 95%, non-condensing (no water drops forming on surfaces).

## Grounding Instructions

**This product must be grounded.** If the treadmill should malfunction or breakdown, proper grounding provides a path of least resistance for electric current, reducing the risk of electric shock. This product is equipped with a cord having an equipment-grounding plug. The plug must be plugged into an appropriate outlet that is properly installed and grounded in accordance with all local codes and ordinances.

**DANGER - Improper connection of the equipment-grounding conductor can result in a risk of electric shock. Check with a qualified electrician or serviceman if you are in doubt as to whether the product is properly grounded. Do not modify the plug provided with the product if it will not fit the outlet; have a proper outlet installed by a qualified electrician.**

This product is for use on a nominal 120-volt circuit, and has a grounding plug that looks like the plug illustrated below. A temporary adapter that looks like the adapter illustrated below may be used to connect this plug to a 2-pole receptacle as shown below if a properly grounded outlet is not available. The temporary adapter should be used only until a properly grounded outlet, (below) can be installed by a qualified electrician. The green colored rigid ear-lug, or the like, extending from the adapter, must be connected to a permanent ground such as a properly grounded outlet box cover. Whenever the adapter is used, it must be held in place by a metal screw.

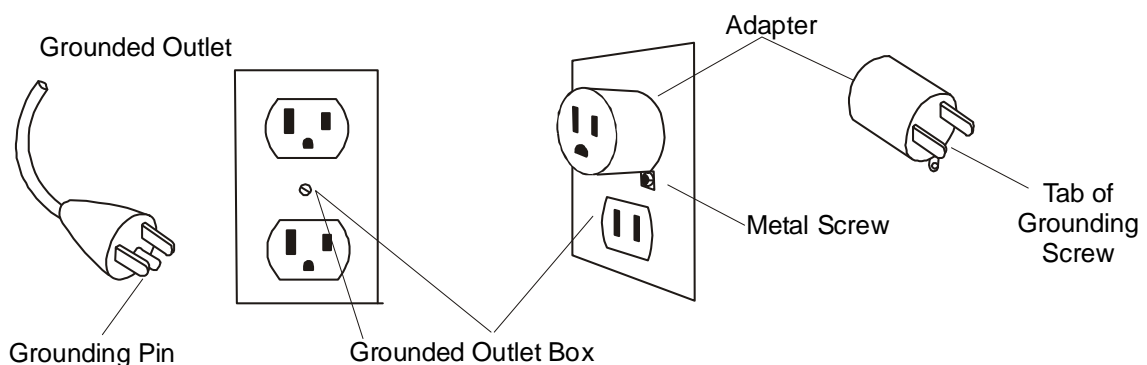

## ***Important Operation Instructions***

- | **NEVER** operate this treadmill without reading and completely understanding the results of any operational change you request from the computer.
- | Understand that changes in speed and incline do not occur immediately. Set your desired speed on the computer console and release the adjustment key. The computer will obey the command gradually.
- | **NEVER** use your treadmill during an electrical storm. Surges may occur in your household power supply that could damage treadmill components.
- | Use caution while participating in other activities while walking on your treadmill; such as watching television, reading, etc. These distractions may cause you to lose balance or stray from walking in the center of the belt, which may result in serious injury.
- | **NEVER** mount or dismount the treadmill while the belt is moving. Spirit treadmills start with at a very low speed and it is unnecessary to straddle the belt during start up. Simply standing on the belt during slow acceleration is proper after you have learned to operate the unit.
- | Always hold on to a handrail or hand bar while making control changes (incline, speed, etc.).

## ***Safety Tether Cord***

A safety tether cord is provided with this unit. It is a simple magnetic design that should be used at all times. It is for your safety should you fall or move too far back on the tread-belt. Pulling this safety tether cord will stop tread-belt movement.

### **To Use:**

1. Place the magnet into position on the round portion of the console control head. Your treadmill will not start and operate without this. Removing the magnet also secures the treadmill from unauthorized use.
2. Fasten the plastic clip onto your clothing securely to assure good holding power. **Note:** The magnet has strong enough power to minimize accidental, unexpected stopping. The clip should be attached securely to make certain it does not come off. Be familiar with its function and limitations. The treadmill will stop, depending on speed, with a one to two step coast anytime the magnet is pulled off the console.

# ASSEMBLY PACK CHECK LIST

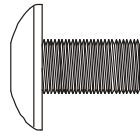

**#84 - 5/16" x 1/2"**  
Button Head Socket Bolt (2pcs)

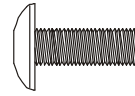

**#60 - M5 x 15mm**  
Phillips Head Screw (4pcs)  
(These four screws are attached to the back of the console)

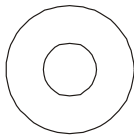

**#69 - 5/16" x 18mm**  
Flat Washer (6pcs)

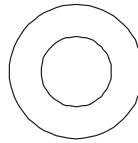

**#71 - 3/8" x 19mm**  
Flat Washer (2pcs)

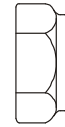

**#65 - 3/8"**  
Nyloc Nut (2pcs)

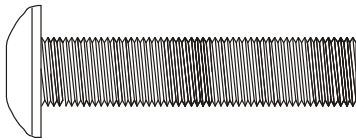

**#55 - 3/8" x 46mm**  
Button Head Socket Bolt (2pcs)

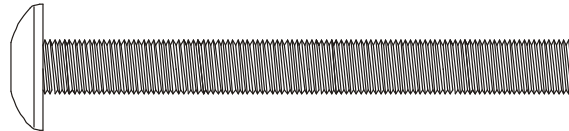

**#83 - 5/16" x 3"**  
Button Head Socket Bolt (4pcs)

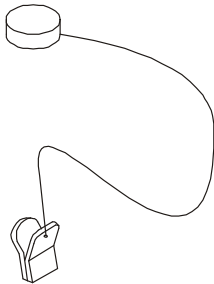

**#37 - Safety Key (1pc)**

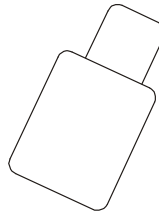

**#87 - Lubricant (1pc)**

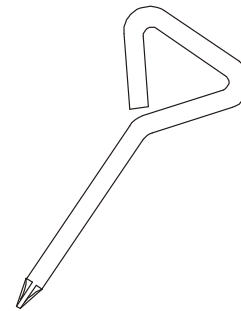

**#94 - Short Phillips Head Screw Driver (1pc)**

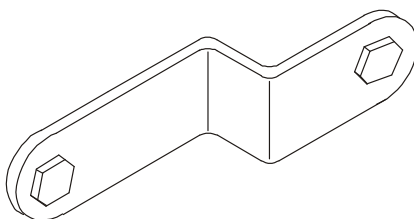

**#86 - 13/14 mm Wrench (1pc)**

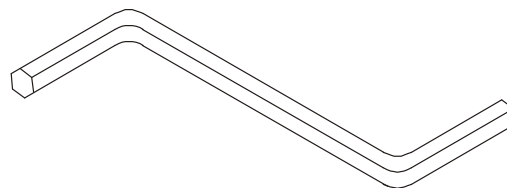

**#85 - M5/M6 Allen Wrench (1pc)**

# Assembly Instructions for ET188

n **STEP 1**

Remove all the parts from the carton.

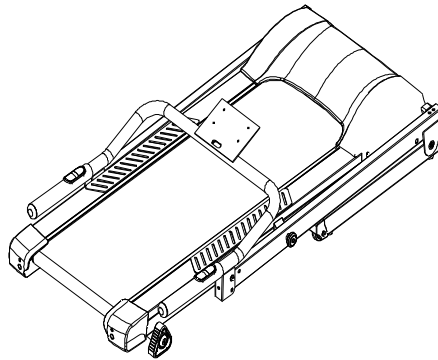

n **STEP 2**

Raise the upright supports into place as shown. Secure the uprights with the four 5/16" x 3" socket head bolts (83) and 5/16" flat washers (69).

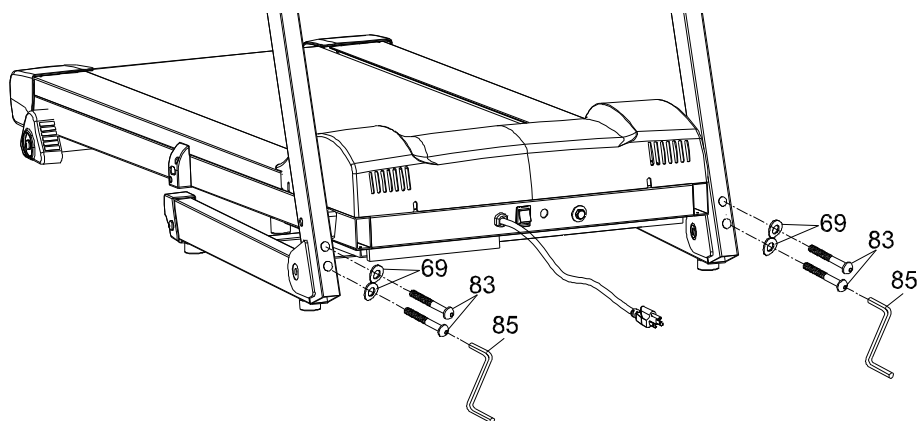
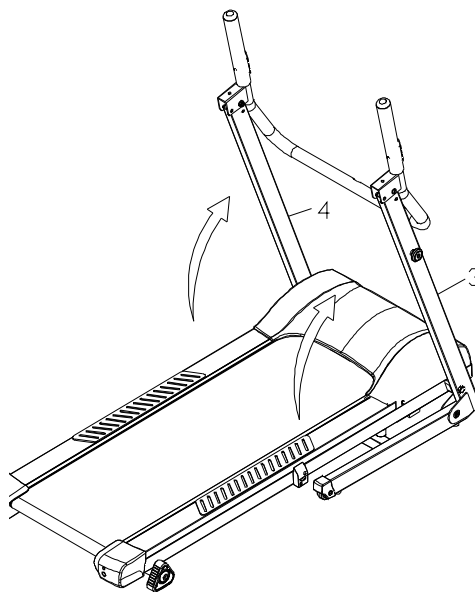



n **STEP 3**

Install, and just hand tighten for now, the two 5/16" x 1/2" socket head bolts (84) and 5/16" flat washers (69) into the front of the left and right upright tubes. Now install the 3/8" x 46mm socket head bolts (55) from the outside of the upright tubes, 3/8" flat washers (71) and 3/8" nuts from the inside of the uprights and tighten all four bolts as tight as possible.

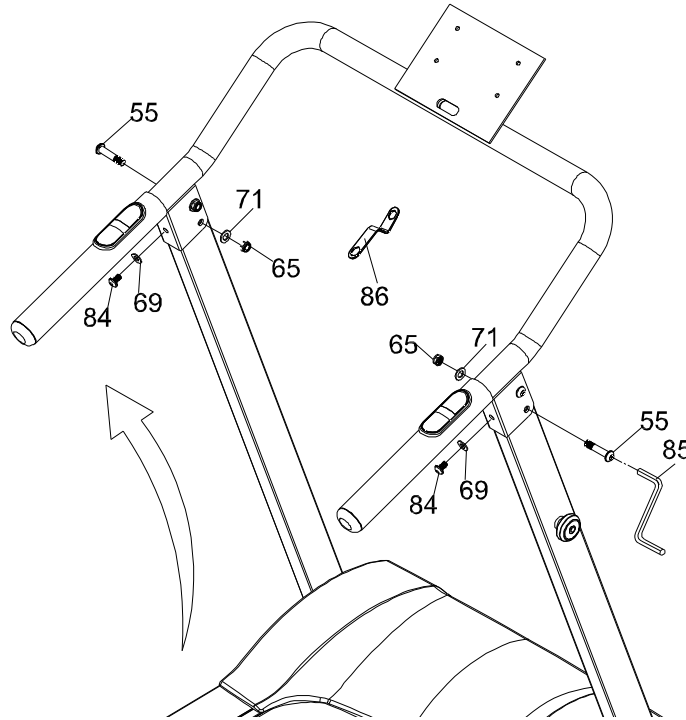

n **STEP 4**

Connect the computer cable (38) and pulse sensor wires (93) to the mating connectors on the back of the console. Secure the console in place with the four M5 x 15mm screws (60).

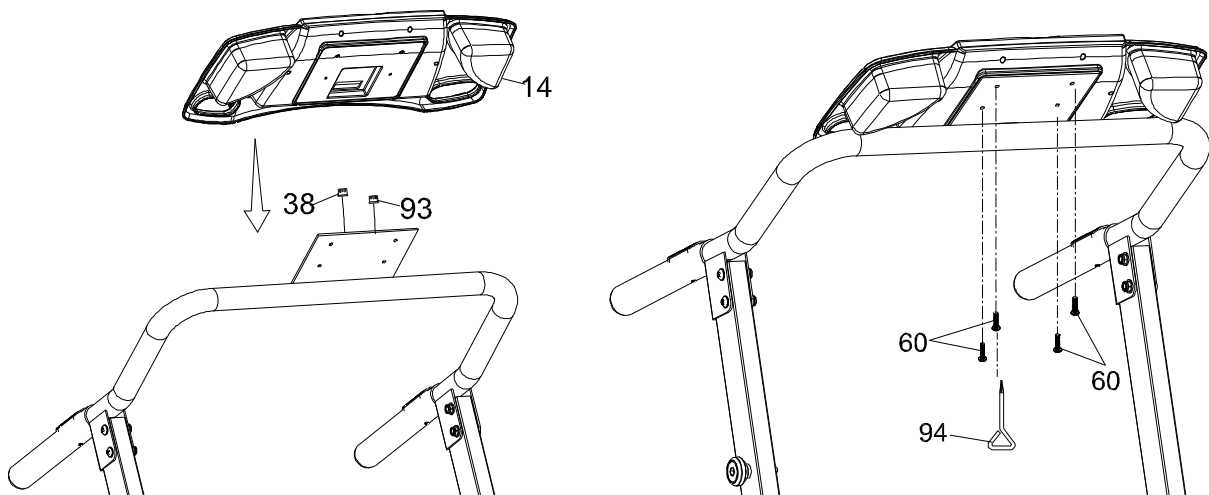

# Operation of Your Treadmill



## GETTING STARTED:

Power the treadmill on by plugging it into a grounded wall outlet, then turn on the power switch located at the front of the treadmill below the motor hood. Ensure that the safety key is installed, as the treadmill will not operate without it.

When the power is initially turned on, the display will light up and then show an Odometer and Time reading. The odometer reading shows how many virtual miles the treadmill gone and Time shows how many hours it has been in use. The display will also show a software version; i.e. VER 1.0. The console will now be in idle mode, which is the starting point for operation.

## QUICK START:

After the treadmill is powered on and the safety key is in place simply press the START key. The treadmill will start at the minimum speed of 0.5 mph, the time will count up from zero and all data will begin to accrue. You can adjust the speed manually by pressing the Fast and Slow buttons or the **Quick Keys** labeled: **Walk** (3mph), **Jog** (5mph) and **Run** (7 mph).

## **WINDOW DISPLAYS:**

<b>DISTANCE:</b>	Accumulates total workout distance from 0.00 to 99.99 miles (km).
<b>TIME:</b>	Accumulates total workout time from 00:00 to 99:59.
<b>CALORIES:</b>	Accumulates the user's calorie consumption during exercise.
<b>PROGRAM:</b>	Indicates which program is currently running.
<b>LAPS:</b>	Counts the number of laps you have gone around the ¼ mile track.
<b>PULSE:</b>	Shows your heart rate in beats per minute
<b>SPEED</b>	Shows your current walking/running speed in Miles Per Hour.
<b>LUBE:</b>	Reminds user to apply silicon lubricant between the belt and deck. If "ODO" or "HRS", reach their target ("HRS" is 180 hours or "ODO" is 600 mi.) the display window will light an indicator next to the "Lube" icon on the console overlay. To turn off the Lube message, press and hold the stop button for 3 seconds.

## **BUTTON FUNCTIONS:**

<b>START:</b>	Press the "START" button to begin a program.
<b>STOP:</b>	Press the "STOP" button to stop training, and press for 3 seconds to reset.
<b>FAST:</b>	Press the "FAST" button to increase your speed.
<b>SLOW:</b>	Press the "SLOW" button to decrease your speed.
<b>MODE:</b>	Press the "MODE" button to select different parameters during programming.
<b>PROGRAM:</b>	Press the program buttons to choose one of the preset programs.
<b>SAFETY KEY:</b>	Put safety key in position to enable the computer. When the safety key is pulled away from its position, the computer will automatically shut down the motor.
<b>QUICK KEYS:</b>	Allows you to jump to a set speed at the touch of a button. Walk = 3mph, Jog = 5mph, Run = 7mph.

## **PROGRAMS:**

### **MANUAL P0**

- Step 1.** Press the Program key to select Manual.
- Step 2.** You can press the MODE button to set the program Time, Distance or Calories. When you set one of these targets and start the program, the number in that window will count down and when it reaches zero the program ends.

### **PROGRAMS 1~3**

- Step 1.** Press the Program key to select one of the programs.
- Step 2.** Press the Mode key to set the workout time; the default time is 20 minutes.
- Step 3.** Press Start to begin your workout.

## PRESET PROGRAMS (P1, P2, P3)

- Program 1 is a walking program

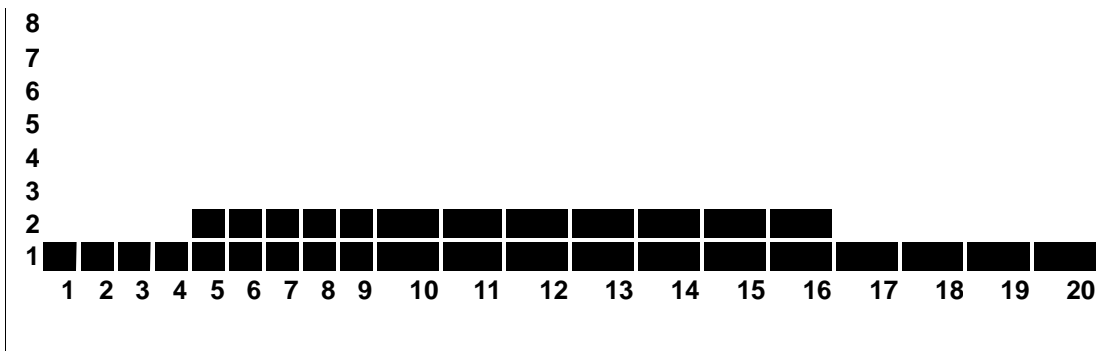

P1 Speed settings in mph for each segment of the profile:

P1	0.6	0.7	0.9	1.0	1.2	1.2	1.2	1.2	1.2	1.2	1.2	1.2	1.2	1.2	1.2	1.2	1.0	0.9	0.7	0.6
----	-----	-----	-----	-----	-----	-----	-----	-----	-----	-----	-----	-----	-----	-----	-----	-----	-----	-----	-----	-----

- Program 2 is a Jogging program

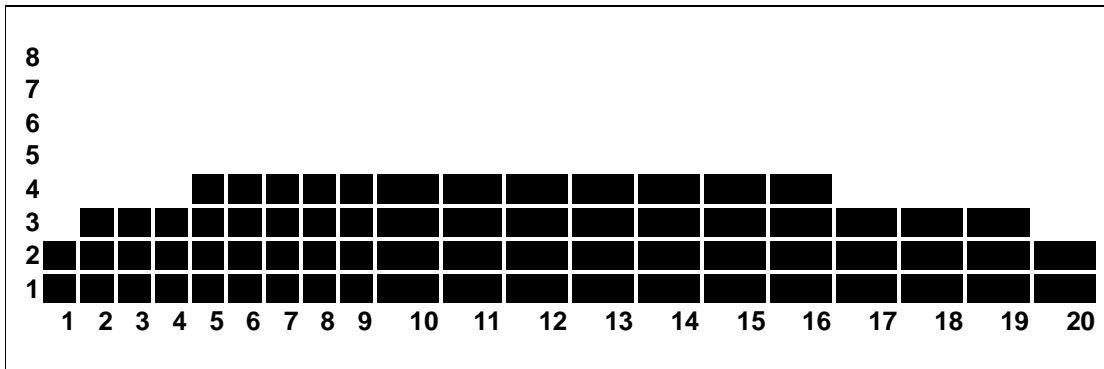

P2 Speed settings in mph for each segment of the profile

P2	1.9	2.1	2.6	3.0	3.6	3.6	3.6	3.6	3.6	3.6	3.6	3.6	3.6	3.6	3.6	3.6	3.0	2.6	2.1	1.9
----	-----	-----	-----	-----	-----	-----	-----	-----	-----	-----	-----	-----	-----	-----	-----	-----	-----	-----	-----	-----

- Program 3 is a Running program:

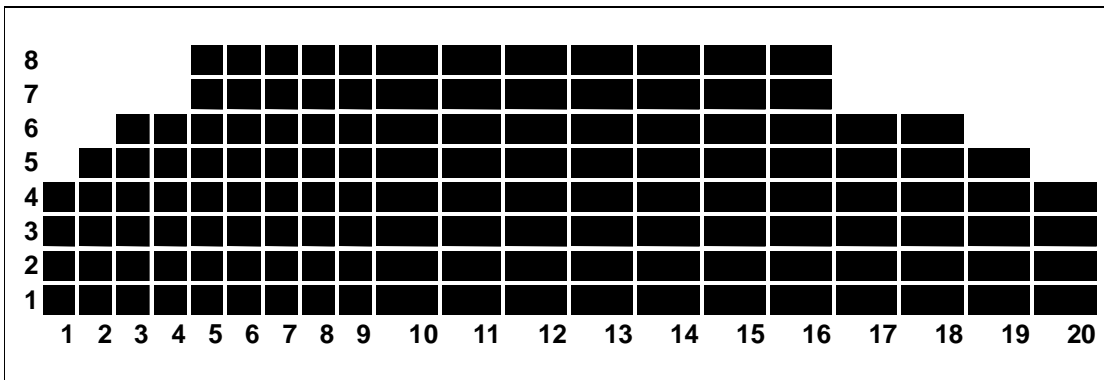

P3 Speed settings in mph for each segment of the profile

P3	3.8	4.3	5.1	6.1	7.3	7.3	7.3	7.3	7.3	7.3	7.3	7.3	7.3	7.3	7.3	7.3	6.1	5.1	4.3	3.8
----	-----	-----	-----	-----	-----	-----	-----	-----	-----	-----	-----	-----	-----	-----	-----	-----	-----	-----	-----	-----

# General Maintenance

**Belt and Bed** - Your treadmill uses a very high-efficient low-friction bed. Performance is maximized when the bed is kept as clean as possible. Use a soft, damp cloth or paper towel to wipe the edge of the belt and the area between the belt edge and frame. Also reach as far as practical directly under the belt edge. This should be done once a month to extend belt and bed life. Use water only - no cleaners or abrasives. A mild soap and water solution along with a nylon scrub brush will clean the top of the textured belt. **Allow the belt to dry before using.**

**Belt Dust** - This occurs during normal break-in or until the belt stabilizes. Wiping excess off with a damp cloth will minimize buildup.

**General Cleaning** - Dirt, dust, and pet hair can block air inlets and accumulate on the running belt. On a monthly basis: vacuum underneath your treadmill to prevent buildup. Once a year, you should remove the black motor hood and vacuum out dirt that may accumulate. **UNPLUG POWER CORD BEFORE THIS TASK.**

## BELT ADJUSTMENTS:

**Treadbelt Tension Adjustment** - Belt tension is not critical for most users. It is very important for joggers and runners in order to provide a smooth, steady running surface. Adjustment must be made from the right side of the rear roller in order to adjust tension with the 6 mm Allen wrench provided in the parts package. The adjustment bolt is located at the end of the right side rail as noted in diagram below.

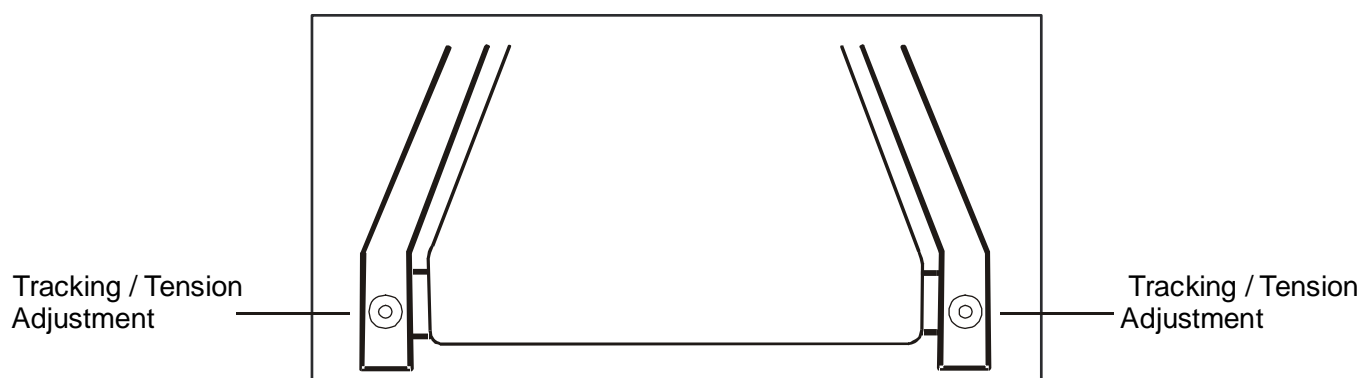

**Note:** Adjustment is through small hole in end

Tighten the rear roller only enough to prevent slippage at the front roller. Turn the tread-belt tension adjustment bolt in increments of 1/4 turn and inspect for proper tension.

**When an adjustment is made to the belt tension, you must also make a tracking adjustment to compensate for the change in belt tension.** This is accomplished by turning both the tension and tracking Allen bolts an equal amount. This adjustment is accomplished by turning both bolts clockwise no more than a 1/4 turn at a time.

**DO NOT OVERTIGHTEN** – Over tightening will cause belt damage and premature bearing failure.

## TREADBELT TRACKING ADJUSTMENT:

The performance of your treadmill is dependent on the frame running on a reasonably level surface. If the frame is not level, the front and back roller cannot run parallel, and constant belt adjustment may be necessary.

The treadmill is designed to keep the tread-belt reasonably centered while in use. It is normal for some belts to drift near one side while the belt is running with no one on it. After a few minutes of use, the tread-belt should have a tendency to center itself. If, during use, the belt continues to move toward one side, adjustments are necessary.

## TO SET TREADBELT TRACKING:

A 6 mm Allen wrench is provided to adjust the rear roller. Make tracking adjustments from the **left** side only. Set belt speed at

approximately 2 to 3 mph. A small adjustment can make a dramatic difference. Turn the bolt only a 1/4 turn and wait a few minutes for the belt to adjust itself.

Continue to make 1/4 rotation turns until the belt stabilizes in the center of the running deck. The belt may require periodic tracking adjustment depending on use and walking/running characteristics.

Some users will affect tracking differently.

Expect to make adjustments as required to center the tread-belt. Adjustments will become less of a maintenance concern as the belt is used. Proper belt tracking is an owner responsibility common with all treadmills.

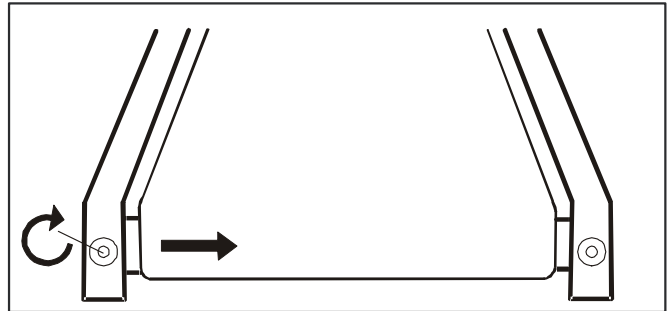

## ATTENTION:

**DAMAGE TO THE RUNNING BELT RESULTING FROM IMPROPER TRACKING / TENSION ADJUSTMENTS IS NOT COVERED UNDER THE SPIRIT WARRANTY.**

## MAINTENANCE MODE:

If you want to set the Speed and Distance to Metric or if there is a problem with the speed and you would like to perform the calibration procedure, use the Maintenance Mode. To enter Maintenance Mode press, and hold for 5 seconds, the Start, Stop and Mode keys while installing the safety key.

- The dot matrix display will now be showing the word SET
- The Speed window will show a number for the roller size, press the up and/or Down key to adjust the roller size. The roller size for the ET188 is **1.8**
- The Speed window will also display the setting for M (miles) or Km (Kilometers). Press the Stop key to change between M and Km.
- To run the calibration procedure, press the Start key.
  - The display will show a number for the lowest speed setting (for miles the number should be 0.5). Adjust the low speed setting and press Start.
  - The display will show a number for the top speed setting (for Miles it should be 8.0). Adjust the top speed setting and press Start to begin calibration.
  - The belt will start automatically and will adjust speeds between low and high. Be careful because the belt will change speeds without warning. When the calibration is finished the display will return to the start-up screen.

## **BELT / DECK LUBRICATION:**

Do not lubricate with other than Spirit approved lubricant. Your treadmill comes with one tube of lubricant and extra tubes can be ordered directly from Spirit. There are commercially available lube kits, but the only one currently approved by Spirit is Lube-N-Walk. These kits come with an application wand that makes applying the lubrication easier. The kits can be purchased from Spirit or directly from Lube-N-Walk here: <http://www.jadfitness.com/> When ordering make sure to specify silicone lubricating kit, not paraffin wax.

Keeping the deck lubricated at the recommended intervals ensures the longest life possible for your treadmill. If the lubricant dries out, the friction between the belt and deck rises and places undue stress on the drive motor, drive belt and electronic motor control board, which could result in catastrophic failure of these expensive components. Failure to lubricate the deck at regular intervals may void the warranty.

The deck comes pre-lubricated and subsequent lubrication should be performed every 180 hours of use. The console has a built in lubrication reminder indicator that lights every 180 hours of use. To lubricate the deck with the tube of lubricant supplied it will be necessary to loosen the walking belt. Using the 6 mm allen wrench supplied, loosen the two rear roller adjustment bolts -- located in the rear end caps -- enough to get your hand under the belt (5 –10 turns). Make sure to loosen both bolts the same amount of turns and also remember how many turns, because when finished you will need to tighten the bolts back to the point they were before.

Once the belt is loose, wipe the deck with a clean lint free cloth to remove any dirt. Apply the whole tube of lubricant onto the deck surface about 18 inches from the motor cover. Squeeze out the contents of the tube across the deck (parallel to the motor cover) in about a one-foot long line, like toothpaste on a toothbrush. The one-foot line should be in the middle of the deck at approximately equal distance from both side edges of the belt. You want the lubricant to be applied about the spot that your feet would hit the belt as you are walking. This should be about 18 inches from the motor cover, but you may want to walk on the treadmill before loosening the belt to note where your feet land on the belt. If you mostly run on the treadmill, the spot where your feet land may be different from walking.

Once the lubricant is applied, tighten the rear roller bolts the same amount of turns as when you loosened them. Run the treadmill at about 6 mph without walking on it for about a minute or two to make sure the belt stays in the middle of the deck. If the belt tracks to one side then follow the belt tracking instructions to remedy. Now the deck is lubricated and you should walk, not run, on the treadmill immediately for at least 5 minutes to ensure the lubricant is evenly distributed. If you purchase a Lube-N-Walk kit, follow the instructions that come with it to apply the lubrication.

# Service Checklist - Diagnosis Guide

Before contacting your dealer for aid, please review the following information. It may save you both time and expense. This list includes common problems that may not be covered under the treadmill's warranty.

PROBLEM	SOLUTION/CAUSE
Display does not light	Tether cord not in position. Circuit breaker on front grill tripped. Push circuit breaker in until it locks. Plug is disconnected. Make sure plug is firmly pushed into the AC household wall outlet. Household circuit breaker may be tripped. Treadmill defect. Contact your Spirit dealer.
Treadmill belt does not stay centered Treadmill belt hesitates when walked/run on	A user may be walking while favoring or putting more weight on either the left or right foot. If this walking pattern is natural, track the belt slightly off-center to the side opposite from the belt movement. See General Maintenance section on Treadmill belt Tension. Adjust as necessary.
Motor is not responsive / Display is lit	Make certain clock is running. If it is then service may be needed.
Treadmill will only achieve approximately 3 mph but shows higher speed on display	This indicates motor should be receiving power to operate. Low AC voltage to treadmill. Do not use an extension cord. If an extension cord is required it should be as short as possible and heavy duty 16 gauge minimum. Low household voltage. Contact an electrician or your Spirit dealer. A minimum of 110 volt AC current is required.
Treadmill belt stops quickly/suddenly when tether cord is pulled	High belt/deck friction. See General Maintenance section on lubrication.
Treadmill trips on board 15 amp circuit	High belt/deck friction. See Belt/deck lubrication procedure
Computer shuts off when console is touched (on a cold day)while walking/running	Treadmill is not grounded. Static electricity is "crashing" the computer. Refer to Grounding Instructions on page 4.

## ERROR MESSAGES:

- LS:** The treadmill hasn't received a speed signal for 8 seconds.
- E1:** Console memory malfunction or CPU problem.
- E2:** Incline position error



# Manufacturer's Limited Warranty

## Effective July 15, 2009 TREADMILL LIMITED WARRANTY

Spirit Fitness Inc. warrants all its home use treadmill parts for a period of time listed below, from the date of retail sale, as determined by a sales receipt or in the absence of a sales receipt, eighteen (18) months from the original factory shipping date. Spirit's responsibilities include providing new or remanufactured parts, at Spirit's option, and technical support to our independent dealers and servicing organizations. In the absence of a dealer or service organization, these warranties will be administered by Spirit Fitness directly to a consumer. The warranty period applies to the following components:

### Home Use Limited WARRANTY

Frame	5 Years
Motor	1 Year
Deck	90 Days
Parts	90 Days
Labor	90 Days

### NORMAL RESPONSIBILITIES OF THE CONSUMER

This warranty applies only to products in ordinary household use. The consumer is responsible for the items listed below:

1. The warranty registration card must be completed and returned to the address listed on the card within 10 days of the original purchase to validate the manufacturer's limited warranty or register online at [www.spiritfitness.com/warranty.asp](http://www.spiritfitness.com/warranty.asp)
2. Proper use of the elliptical in accordance with the instructions provided in this manual, including maintenance.
3. Proper connection to a power supply of sufficient voltage, replacement of blown fuses, repair of loose connections or defects in house/facility wiring.
4. Expenses for making the elliptical accessible for servicing, including any item that was not part of the elliptical at the time it was shipped from the factory.
5. Damages to the elliptical finish during shipping, installation or following installation.

### EXCLUSIONS

This warranty does not cover the following:

1. CONSEQUENTIAL, COLLATERAL, OR INCIDENTAL DAMAGES SUCH AS PROPERTY DAMAGE AND INCIDENTAL EXPENSES RESULTING FROM ANY BREACH OF THIS WRITTEN OR ANY IMPLIED WARRANTY.

*Note: Some states do not allow the exclusion or limitation of incidental or consequential damages, so this limitation or exclusion may not apply to you.*

2. Service call reimbursement to the consumer. Service call reimbursement to the dealer that does not involve malfunction or defects in workmanship or material, for units that are beyond the warranty period, for units that are beyond the service call reimbursement period, for ellipticals not requiring component replacement, or ellipticals not in ordinary household use.
3. Damages caused by services performed by persons other than authorized Spirit Fitness service companies, use of parts other than original Spirit parts, or external causes such as alterations, modifications, abuse, misuse, accident, improper maintenance, inadequate power supply, or acts of God.
4. Products with original serial numbers that have been removed or altered.
5. Products that have been; sold, transferred, bartered, or given to a third party.
6. Products that are used as store display models.
7. Products that do not have a warranty registration on file at Spirit Fitness, inc. Spirit Fitness reserve the right to request proof of purchase if no warranty record exists for the product.
8. THIS WARRANTY IS EXPRESSLY IN LIEU OF ALL OTHER WARRANTIES EXPRESSED OR IMPLIED, INCLUDING THE WARRANTIES OF MERCHANTABILITY AND/OR FITNESS FOR A PARTICULAR PURPOSE.

### SERVICE

Keep your bill of sale. Twelve (12) months from the date on the bill of sale or eighteen (18) months from the date of factory shipping as determined by the serial number establishes the warranty period should service be required. If service is performed, it is in your best interest to obtain and keep all receipts. This written warranty gives you specific legal rights. You may also have other rights that vary from state to state. Service under this warranty must be obtained by following these steps, in order:

1. Contact your selling authorized Spirit Fitness dealer. OR
2. Contact your local authorized Spirit Fitness service organization.
3. If there is a question as to where to obtain service, contact our service department at (870) 935-1107.
4. Spirit's obligation under this warranty is limited to repairing or replacing, at Spirit's option, the product through one of our authorized service centers. All repairs must be preauthorized by Spirit. If the product is shipped to a service center freight charges to and from the service center will be the customer's responsibility. For replacement parts shipped while the product is under warranty, the customer will be responsible for shipping and handling charges. For in-home service, the customer will be responsible for a trip charge. There will be an additional trip charge if the customer is located over 100 miles from the nearest service center.
5. The owner is responsible for adequate packaging upon return to Spirit. Spirit is not responsible for damages in shipping. Make all freight damage claims with the appropriate freight carrier. DO NOT SHIP ANY UNIT TO OUR FACTORY WITHOUT A RETURN AUTHORIZATION NUMBER. All units arriving without a return authorization number will be refused.
6. For any further information, or to contact our service department by mail, send your correspondence to:

**Spirit Fitness, Inc.**  
**P.O. Box 2037**  
**Jonesboro, AR 72402-2037**

Product features or specifications as described or illustrated are subject to change without notice. All warranties are made by Spirit Fitness, Inc. This warranty applies only in the 50 states of the U.S.A.