

# *LINKS<sup>2</sup>*

**NHTC NORTEC  
LINKS 2 OPTIONS**

**Installation Manual**

## PROPRIETARY NOTICE

This document and the information disclosed herein are proprietary data of WALTER MEIER LTD. Neither this document nor the information contained herein shall be reproduced used, or disclosed to others without the written authorization of WALTER MEIER LTD., except to the extent required for installation or maintenance of recipient's equipment. All references to the NORTEC name should be taken as referring to WALTER MEIER LTD.



## LIABILITY NOTICE

NORTEC does not accept any liability for installations of humidity equipment installed by unqualified personnel or the use of parts/components/equipment that are not authorized or approved by NORTEC.

## COPYRIGHT NOTICE

Copyright 2008, WALTER MEIER LTD. All rights reserved.

## RECORD OF REVISIONS

For each revision, put the revised pages in your manual and discard the superseded pages. Write the revision number and revision date, date put in manual, and the incorporator's initials in the applicable columns on the Record of Revisions.

Revision Number	Revision Date	Date Put In Manual	By	Revision Number	Revision Date	Date Put In Manual	By

## TABLE OF CONTENTS

Subject	Page
<b>10-00 INTRODUCTION</b>	
1. OVERVIEW .....	2
<b>10-10 INSTALLATION PROCEDURES</b>	
1. NETWORKING .....	2
2. WIRING .....	3
A. BACNET/MSTP, JOHNSON N2, AND LONWORKS .....	3
B. BACNET/IP .....	3
3. GATEWAY CONFIGURATION .....	4
4. NETWORK INTEGRATION .....	4
A. LONWORKS.XIF FILE .....	4
B. BACNET PICS AND BIBS. ....	4
5. VARIABLE DEFINITION .....	5
<b>10-20 START-UP</b>	
1. NORTEC LINKS 2 START-UP CHECKLIST .....	2
2. START-UP PROCEDURE .....	2
<b>10-30 TROUBLESHOOTING</b>	
1. TROUBLESHOOTING .....	2
2. INDICATOR LIGHTS .....	2
<b>10-40 SPARE PARTS</b>	
1. REPLACEMENT PARTS .....	2
<b>10-50 TECHNICAL</b>	
1. WIRING DIAGRAMS .....	2
<b>WARRANTY</b>	

## LIST OF FIGURES

Figure	Page
<b>10-10 INSTALLATION</b>	
Figure 1. Sample Humidification Applications - Room-Sensed %RH Feedback with Duct Hi-Limit Sensing . . .	16
Figure 2. Sample Humidification Applications - Control Feedback (0-100%) with Duct Hi-Limit Sensing . . .	16
Figure 3. Sample Humidification Applications - 0-10V Signal Directly to Humidifier) . . . . .	17
<b>10-30 TROUBLESHOOTING</b>	
Figure 1. OnLine Diagnostic LED Locations . . . . .	3
Figure 2. BACnet Module LED . . . . .	3
Figure 3. LonWorks Module LED. . . . .	3
Figure 4. Ethernet Port . . . . .	3
<b>10-40 SPARE PARTS</b>	
Figure 1. BACnet or N2 Module. . . . .	3
Figure 2. LonWorks Module. . . . .	3
Figure 3. OnLine Module . . . . .	3
Figure 4. Ethernet Router . . . . .	3
Figure 5. Ethernet Switchch . . . . .	4
<b>10-50 TECHNICAL</b>	
Figure 1. Wiring Diagram - NHTC LINKS II BACnet/IP Option . . . . .	2
Figure 2. Wiring Diagram - NHTC LINKS II LonWorks Option. . . . .	3
Figure 3. Wiring Diagram - NHTC LINKS II Option . . . . .	4

## LIST OF TABLES

Table	Page
<b>10-00 INTRODUCTION</b>	
Table 1. Protocol Options . . . . .	2
<b>10-10 INSTALLATION</b>	
Table 1. Recommended Wire Types and Lengths . . . . .	3
Table 2. Baud Rates . . . . .	4
Table 3. Variable Definitions. . . . .	6
Table 4. Variable Addresses Unit #1 . . . . .	8
Table 5. Variable Addresses Unit #2 . . . . .	9
Table 6. Variable Addresses Unit #3 . . . . .	10
Table 7. Variable Addresses Unit #4 . . . . .	11
Table 8. Variable Addresses Unit #5 . . . . .	12
Table 9. Variable Addresses Unit #6 . . . . .	13
Table 10. Variable Addresses Unit #7 . . . . .	14
Table 11. Variable Addresses Unit #8 . . . . .	15
<b>10-30 TROUBLESHOOTING</b>	
Table 1. OnLine Diagnostic LED Description . . . . .	4
Table 2. LINKS 2 Module Diagnostic LEDs . . . . .	5
Table 3. Troubleshooting Communication Problems . . . . .	6
<b>10-40 SPARE PARTS</b>	
Table 1. Replacement Parts . . . . .	2

**THIS PAGE INTENTIONALLY LEFT BLANK**

# 10-00

# INTRODUCTION

## (1) OVERVIEW

- (1) The NHTC Nortec LINKS 2 Option allows for the integration of a NHTC Series humidifier within a BACnet, Johnson N2 or LonWorks network and allows those units to concurrently be monitored via the Nortec OnLine interface. This option features a Nortec OnLine module co-existing with a gateway that has the capability of converting information from the host Modbus protocol to a specified secondary protocol.
- (2) The following protocol options are available and must be specified when ordering:

**Table 1. Protocol Options**

<b>Protocol</b>	<b>Default Baud Rates</b>
BACnet MS/TP	38.4 kbps
BACnet / IP	10BaseT
Johnson N2	9.6 kbps

# 10-10 INSTALLATION



## **(1) NETWORKING**

- (1) It is possible to network up to a maximum of 8 units to a single LINKS 2. Since each unit is separately addressed, it is possible to monitor and control each unit individually. Different networking configurations may be achieved and are mostly dependant on the type of network present at the site. One networking example could have a Gateway installed inside the lead unit, which could then be daisy-chained to successive units. In turn, the lead unit would connect to a Building Management System (BMS) network via a shielded, twisted-pair connection. Please see wiring section for additional detail. A second example could have a series of units directly connected to an Ethernet network. This is only possible for BACnet communication and is essentially referred to as a BACnet/IP configuration.

**(2) WIRING**

**(A) BACNET/MSTP, JOHNSON N2, AND LONWORKS**

- (1) The necessary internal wiring for the Gateway is already present except for the BMS network connection that can be made via twisted-pair at terminals A and B. To network multiple units to a single Gateway, the units may be daisy-chained to each other using the network link terminals at the TB3 connection jack on the humidifier logic board. Refer to wiring diagram in section 10-50.
- (1) Table #1 refers to the recommended wire types and maximum recommended lengths from the Nortec LINK 2 module to the front-end of the Building Management system. Since communication between the humidifiers and Nortec Links will always occur via a EIA-485 signal type, Nortec recommends using a 18-24 AWG shielded, twisted pair wire between the lead humidifier and each of the slave humidifiers. Cable runs between the Nortec LINKS 2 module and the furthest slave humidifier should not exceed 2,000 feet. Signal boosters or repeaters may be necessary for longer wire runs or where electrical noise interference is prevalent.

**Table 1. Recommended Wire Types and Lengths**

Protocol	Signal Type	Polarity		Recommended Cable	Maximum Recommended Distance from Nortec Module
		A	B		
BACnet MS/TP	EIA-485, 2-wire	Net +	Net -	18-24 AWG Shielded, Twisted Pair	2300 ft at 9,600 kbps 2000 ft at 38,400 kbps
Johnson N2					
BACnet/IP	LAN standard	N/A	N/A	CAT.5E cable with RJ-45 termination	Depends on cable manufacturer
LonWorks	EIA-232, 2-wire	Tx	Rx	18-24 AWG Twisted Pair	Should not exceed 50 ft.

**(B) BACNET/IP**

- (1) The necessary wiring for the Gateway is present except for the network cable, which must be connected to the RJ-45 (Ethernet) jack on the Gateway. Refer to wiring diagram in section 10-50.

### (3) GATEWAY CONFIGURATION

- (1) Protocol configuration is made at the factory, prior to final testing. Baud rates are also adjusted to the following values:

**Table 2. Baud Rates**

Protocol	Default Baud Rates
BACnet MS/TP	38.4 kbps
BACnet / IP	10BaseT
Johnson N2	9.6 kbps

- (2) For BACnet/IP, BACnet/MSTP and Johnson N2 applications, it is necessary to establish the modules network address parameters in order access it. Address assignments can be configured at the factory or Nortec can provide instructions to modify the address settings in the field.

### (4) NETWORK INTEGRATION

#### (A) LONWORKS.XIF FILE

- (1) To facilitate the integration of a LonWorks unit within a network, it may be desirable to obtain an External Interface File (XIF). Files of type .xif are used to convey the resources, specific objects and data types which a LonWorks device possesses. The .xif file allows a network integrator to simulate the presence of a networked humidifier even if it is not yet physically connected to the network. In fact, if the integrator has the .xif files of all network devices, a complete system could be simulated and configured off-line. Once the configuration is done, the integrator's software tool can be connected to the actual system and the configuration information can be downloaded. If a .xif file is required prior to installing a LonWorks-enabled humidifier, please contact the factory to obtain it.

#### (B) BACNET PICS AND BIBS

- (1) The Protocol Implementation Conformance Statement or "PICS" describes the BACnet capabilities of a particular BACnet implementation. It is a written document, created by the manufacturer of a device, which identifies the particular options specified by BACnet that are implemented in the device.
- (2) BACnet Interoperability Building Blocks (BIBBs) describe a list of services a BACnet device provides. The main areas that the building blocks are concerned with include: data sharing, trends, schedules, device and system management. BIBBs help specify the interoperability capabilities of a BACnet device. Please contact the factory to obtain a PICS statement or BIBBs profile.

## **(5) VARIABLE DEFINITION**

### **IMPORTANT:**

In the variable name, “\_x” denotes the humidifier number. If there is only one GSTC humidifier, all variable names will end in “\_1”. If two units are networked together (see Figure 4), the second unit’s variable names will end in “\_2”. For 3 networked units, “\_3” and so on. If unsure of the unit number, each unit will have a label indicating the device instance of each humidifier. If unsure of the unit number, each unit will have a label, in the electrical compartment close to the terminal strip, indicating the device instance of each humidifier.

- (1) Nortec LINKS 2 monitors a variety of variables for each unit that is connected to it. For a variable listing and definition refer to Table 3. Network variable addresses for the humidifiers may be seen in Table 4 to Table 11.

**Table 3. Variable Definitions**

Variable Name	R=Read W=Write	Description	LonWorks SNVT
nvoHourOpt_x	R Analogue Value	Indicates the number of hours the humidifier cylinder has been in operation.	SNVT_count_inc
nvoCapLimit	R Analogue Value	Reads to capacity limitation applied to the unit output. (50-100%)	SNVT_switch
nvoRHDem1_x	R Analogue Value	Reads Ch.1 input signal in %RH or demand to humidifier. (0-100%)	SNVT_switch
nvoSet1_x	R Analogue Value	Reads Ch.1 setpoint setting. (10-90%)	SNVT_switch
nvoRHDem2_x	R Analogue Value	Reads Ch.2 input signal in %RH or demand to humidifier. (0-100%) <i>Unit must be configured for dual channel operation.</i>	SNVT_switch
nvoSet2_x	R Analogue Value	Reads Ch.2 setpoint setting. (10-90%) <i>Unit must be configured for dual channel operation.</i>	SNVT_switch
nvoSysDemand_x	R Analogue Value	Reads humidifier system demand. (0-100%)	SNVT_switch
nviCapLimit	R Analogue Value	Sets the humidifier's unit capacity. (50-100%)	
nviRHDem1_x	W Analogue Value	Writes Ch.1 demand or %RH level. Allows BMS control of humidifier output. (0-100%) <i>Unit must be configured for networked demand</i>	SNVT_switch
nviRHDem2_x	W Analogue Value	Writes Ch.2 demand or %RH level. Allows BMS control of humidifier output. (0-100%) <i>Unit must be configured for networked demand</i>	SNVT_switch
nviSet1_x	W Analogue Value	Writes Ch.1 setpoint (0-90%)	SNVT_switch
nviSet2_x	W Analogue Value	Writes Ch.2 setpoint (0-90%)	SNVT_switch

Variable Name	R=Read W=Write	Description	LonWorks SNVT
nvoFault_x	R Binary Value	Indicates unit fault status. 0=no fault, 1=fault.	SNVT_switch
nvoHWSensor_x	R Binary Value	Indicates if a high-water level condition exists in the humidifier cylinder. 0=normal, 1=high water condition	
nvoNetSensor_x	R Binary Value	Reads configuration status for network-enabled sensing or control. 0=%RH or %demand input <u>is not</u> from the network 1=%RH or %demand input <u>is</u> from the network	SNVT_switch
nvoDisable_x	R Binary Value	Reads remote disable status. 0=humidifier enabled, 1=humidifier disabled by network	SNVT_switch
nvoSecurity_x	R Binary	Indicates security loop status. 0=Sec. loop open, 1=Sec. loop closed	SNVT_switch
nvoService_x	R Binary Value	Reads service requirement status. 0=no service required, 1=service required	SNVT_switch
nvoStatus_x	R Binary Value	Reads humidifier status. 0=standby, 1=humidifying.	SNVT_switch
nvoConnection_x	R Binary Value	Indicates that the Nortec Links module is communicating with the Humidifier	SNVT_switch
nviDisable_x	W Binary Value	Writes remote disable status. 0=humidifier enabled, 1=humidifier disabled from network	SNVT_switch
nviNetSensor_x	W Binary Value	Writes configuration status for network-enabled sensing or control. 0=%RH or %demand input <u>is not</u> from the network 1=%RH or %demand input <u>is</u> from the network	SNVT_switch

**Table 4. Humidifier Variable Addresses  
Unit #1**

NHTC LINKS 2 Variable Listing

Default BACnet/IP Address: 192.168.10.11; Subnet: 255.255.255.0

Default BACnet/MSTP Address: 78

Default Johnson N2 Address: 174

Unit #1	BACnet		Lonworks			N2	
Variable Name	Type	Instance	SNVT	SNVT #	NV Index	Type	Instance
nvoHourOpt_1	AV	1	time_hour	124	1	AI	1
nvoCapLimit_1	AV	2	lev_percent	81	2	AI	2
nvoRHDem1_1	AV	3	lev_percent	81	3	AI	3
nvoSet1_1	AV	4	lev_percent	81	4	AI	4
nvoRHDem2_1	AV	5	lev_percent	81	5	AI	5
nvoSet2_1	AV	6	lev_percent	81	6	AI	6
nvoSysDemand_1	AV	7	lev_percent	81	7	AI	7
nviCapLimit_1	AV	8	lev_percent	81	8	AO	8
nviSet1_1	AV	9	lev_percent	81	9	AO	9
nviSet2_1	AV	10	lev_percent	81	10	AO	10
nviRHDem1_1	AV	11	lev_percent	81	11	AO	11
nviRHDem2_1	AV	12	lev_percent	81	12	AO	12
nviDisable_1	AV	13	switch	95	20	AO	13
Expansion_1	AV	14	N/A	N/A	N/A	AO	14
Expansion_1	AV	15	N/A	N/A	N/A	AO	15
nvoFault_1	BV	1	switch	95	13	Binary In	1
nvoHWSensor_1	BV	2	switch	95	14	Binary In	2
nvoNetSensor	BV	3	switch	95	15	Binary In	3
nvoDisable_1	BV	4	switch	95	16	Binary In	4
nvoSecurity_1	BV	5	switch	95	17	Binary In	5
nvoService_1	BV	6	switch	95	18	Binary In	6
nvoStatus_1	BV	7	switch	95	19	Binary In	7
Expansion_1	BV	8	N/A	N/A	N/A	Binary Out	8
nviNetSensor_1	BV	9	switch	95	21	Binary Out	9
nvoConnection_1	BV	10	switch	95	22	Binary Out	10
Expansion_1	BV	11	N/A	N/A	N/A	Binary Out	11
Expansion_1	BV	12	N/A	N/A	N/A	Binary Out	12
Expansion_1	BV	13	N/A	N/A	N/A	Binary Out	13
Expansion_1	BV	14	N/A	N/A	N/A	Binary Out	14
Expansion_1	BV	15	N/A	N/A	N/A	Binary Out	15

**Table 5. Humidifier Variable Addresses  
Unit #2**

Unit #2 Variable Name	BACnet		Lonworks			N2	
	Type	Instance	SNVT	SNVT #	NV Index	Type	Instance
nvoHourOpt_2	AV	16	time_hour	124	23	AI	16
nvoCapLimit_2	AV	17	lev_percent	81	24	AI	17
nvoRHDem1_2	AV	18	lev_percent	81	25	AI	18
nvoSet1_2	AV	19	lev_percent	81	26	AI	19
nvoRHDem1_2	AV	20	lev_percent	81	27	AI	20
nvoSet2_2	AV	21	lev_percent	81	28	AI	21
nvoSysDemand_2	AV	22	lev_percent	81	29	AI	22
nviCapLimit_2	AV	23	lev_percent	81	30	AO	23
nviSet1_2	AV	24	lev_percent	81	31	AO	24
nviSet2_2	AV	25	lev_percent	81	32	AO	25
nviRHDem1_2	AV	26	lev_percent	81	33	AO	26
nviRHDem2_2	AV	27	lev_percent	81	34	AO	27
nviDisable_1	AV	28	switch	95	42	AO	28
Expansion_2	AV	29	N/A	N/A	N/A	AO	29
Expansion_2	AV	30	N/A	N/A	N/A	AO	30
nvoFault_2	BV	16	switch	95	35	Binary In	16
nvoHWSensor_2	BV	17	switch	95	36	Binary In	17
nvoNetSensor_2	BV	18	switch	95	37	Binary In	18
nvoDisable_2	BV	19	switch	95	38	Binary In	19
nvoSecurity_2	BV	20	switch	95	39	Binary In	20
nvoService_2	BV	21	switch	95	40	Binary In	21
nvoStatus_2	BV	22	switch	95	41	Binary In	22
Expansion_2	BV	23	N/A	N/A	N/A	Binary Out	23
nviNetSensor_2	BV	24	switch	95	43	Binary Out	24
nvoConnection_2	BV	25	switch	95	44	Binary Out	25
Expansion_2	BV	26	N/A	N/A	N/A	Binary Out	26
Expansion_2	BV	27	N/A	N/A	N/A	Binary Out	27
Expansion_2	BV	28	N/A	N/A	N/A	Binary Out	28
Expansion_2	BV	29	N/A	N/A	N/A	Binary Out	29
Expansion_2	BV	30	N/A	N/A	N/A	Binary Out	30



**Table 6. Humidifier Variable Addresses  
Unit #3**

Unit #3	BACnet		Lonworks			N2	
Variable Name	Type	Instance	SNVT	SNVT #	Element	Type	Instance
nvoHourOpt_3	AV	31	time_hour	124	45	AI	31
nvoCapLimit_3	AV	32	lev_percent	81	46	AI	32
nvoRHDem1_3	AV	33	lev_percent	81	47	AI	33
nvoSet1_3	AV	34	lev_percent	81	48	AI	34
nvoRHDem1_3	AV	35	lev_percent	81	49	AI	35
nvoSet2_3	AV	36	lev_percent	81	50	AI	36
nvoSysDemand_3	AV	37	lev_percent	81	51	AI	37
nviCapLimit_3	AV	38	lev_percent	81	52	AO	38
nviSet1_3	AV	39	lev_percent	81	53	AO	39
nviSet2_3	AV	40	lev_percent	81	54	AO	40
nviRHDem1_3	AV	41	lev_percent	81	55	AO	41
nviRHDem2_3	AV	42	lev_percent	81	56	AO	42
nviDisable_3	AV	43	switch	95	64	AO	43
Expansion_3	AV	44	N/A	N/A	N/A	AO	44
Expansion_3	AV	45	N/A	N/A	N/A	AO	45
nvoFault_3	BV	31	switch	95	57	Binary In	31
nvoHWSensor_3	BV	32	switch	95	58	Binary In	32
nvoNetSensor_3	BV	33	switch	95	59	Binary In	33
nvoDisable_3	BV	34	switch	95	60	Binary In	34
nvoSecurity_3	BV	35	switch	95	61	Binary In	35
nvoService_3	BV	36	switch	95	62	Binary In	36
nvoStatus_3	BV	37	switch	95	63	Binary In	37
Expansion_2	BV	38	N/A	N/A	N/A	Binary Out	38
nviNetSensor_3	BV	39	switch	95	65	Binary Out	39
nvoConnection_3	BV	40	switch	95	66	Binary Out	40
Expansion_3	BV	41	N/A	N/A	N/A	Binary Out	41
Expansion_3	BV	42	N/A	N/A	N/A	Binary Out	42
Expansion_3	BV	43	N/A	N/A	N/A	Binary Out	43
Expansion_3	BV	44	N/A	N/A	N/A	Binary Out	44
Expansion_3	BV	45	N/A	N/A	N/A	Binary Out	45

**Table 7. Humidifier Variable Addresses  
Unit #4**

Unit #4 Variable Name	BACnet		Lonworks			N2	
	Type	Instance	SNVT	SNVT #	Element	Type	Instance
nvoHourOpt_4	AV	46	time_hour	124	67	AI	46
nvoCapLimit_4	AV	47	lev_percent	81	68	AI	47
nvoRHDem1_4	AV	48	lev_percent	81	69	AI	48
nvoSet1_4	AV	49	lev_percent	81	70	AI	49
nvoRHDem1_4	AV	50	lev_percent	81	71	AI	50
nvoSet2_4	AV	51	lev_percent	81	72	AI	51
nvoSysDemand_4	AV	52	lev_percent	81	73	AI	52
nviCapLimit_4	AV	53	lev_percent	81	74	AO	53
nviSet1_4	AV	54	lev_percent	81	75	AO	54
nviSet2_4	AV	55	lev_percent	81	76	AO	55
nviRHDem1_4	AV	56	lev_percent	81	77	AO	56
nviRHDem2_4	AV	57	lev_percent	81	78	AO	57
nviDisable_4	AV	58	switch	95	86	AO	58
Expansion_4	AV	59	N/A	N/A	N/A	AO	59
Expansion_4	AV	60	N/A	N/A	N/A	AO	60
nvoFault_4	BV	46	switch	95	79	Binary In	46
nvoHWSensor_4	BV	47	switch	95	80	Binary In	47
nvoNetSensor_4	BV	48	switch	95	81	Binary In	48
nvoDisable_4	BV	49	switch	95	82	Binary In	49
nvoSecurity_4	BV	50	switch	95	83	Binary In	50
nvoService_4	BV	51	switch	95	84	Binary In	51
nvoStatus_4	BV	52	switch	95	85	Binary In	52
Expansion_2	BV	53	N/A	N/A	N/A	Binary Out	53
nviNetSensor_4	BV	54	switch	95	87	Binary Out	54
nvoConnection_4	BV	55	switch	95	88	Binary Out	55
Expansion_4	BV	56	N/A	N/A	N/A	Binary Out	56
Expansion_4	BV	57	N/A	N/A	N/A	Binary Out	57
Expansion_4	BV	58	N/A	N/A	N/A	Binary Out	58
Expansion_4	BV	59	N/A	N/A	N/A	Binary Out	59
Expansion_4	BV	60	N/A	N/A	N/A	Binary Out	60

**Table 8. Humidifier Variable Addresses  
Unit #5**

Unit #5 Variable Name	BACnet		Lonworks			N2	
	Type	Instance	SNVT	SNVT #	Element	Type	Instance
nvoHourOpt_5	AV	61	time_hour	124	89	AI	61
nvoCapLimit_5	AV	62	lev_percent	81	90	AI	62
nvoRHDem1_5	AV	63	lev_percent	81	91	AI	63
nvoSet1_5	AV	64	lev_percent	81	92	AI	64
nvoRHDem1_5	AV	65	lev_percent	81	93	AI	65
nvoSet2_5	AV	66	lev_percent	81	94	AI	66
nvoSysDemand_5	AV	67	lev_percent	81	95	AI	67
nviCapLimit_5	AV	68	lev_percent	81	96	AO	68
nviSet1_5	AV	69	lev_percent	81	97	AO	69
nviSet2_5	AV	70	lev_percent	81	98	AO	70
nviRHDem1_5	AV	71	lev_percent	81	99	AO	71
nviRHDem2_5	AV	72	lev_percent	81	100	AO	72
nviDisable_5	AV	73	switch	95	108	AO	73
Expansion_5	AV	74	N/A	N/A	N/A	AO	74
Expansion_5	AV	75	N/A	N/A	N/A	AO	75
nvoFault_5	BV	61	switch	95	101	Binary In	61
nvoHWSensor_5	BV	62	switch	95	102	Binary In	62
nvoNetSensor_5	BV	63	switch	95	103	Binary In	63
nvoDisable_5	BV	64	switch	95	104	Binary In	64
nvoSecurity_5	BV	65	switch	95	105	Binary In	65
nvoService_5	BV	66	switch	95	106	Binary In	66
nvoStatus_5	BV	67	switch	95	107	Binary In	67
Expansion_2	BV	53	N/A	N/A	N/A	Binary Out	68
nviNetSensor_5	BV	69	switch	95	109	Binary Out	69
nvoConnection_5	BV	70	switch	95	110	Binary Out	70
Expansion_5	BV	71	N/A	N/A	N/A	Binary Out	71
Expansion_5	BV	72	N/A	N/A	N/A	Binary Out	72
Expansion_5	BV	73	N/A	N/A	N/A	Binary Out	73
Expansion_5	BV	74	N/A	N/A	N/A	Binary Out	74
Expansion_5	BV	75	N/A	N/A	N/A	Binary Out	75

**Table 9. Humidifier Variable Addresses  
Unit #6**

Unit #6 Variable Name	BACnet		Lonworks			N2	
	Type	Instance	SNVT	SNVT #	Element	Type	Instance
nvoHourOpt_6	AV	76	time_hour	124	111	AI	76
nvoCapLimit_6	AV	77	lev_percent	81	112	AI	77
nvoRHDem1_6	AV	78	lev_percent	81	113	AI	78
nvoSet1_6	AV	79	lev_percent	81	114	AI	79
nvoRHDem1_6	AV	80	lev_percent	81	115	AI	80
nvoSet2_6	AV	81	lev_percent	81	116	AI	81
nvoSysDemand_6	AV	82	lev_percent	81	117	AI	82
nviCapLimit_6	AV	83	lev_percent	81	118	AO	83
nviSet1_6	AV	84	lev_percent	81	119	AO	84
nviSet2_6	AV	85	lev_percent	81	120	AO	85
nviRHDem1_6	AV	86	lev_percent	81	121	AO	86
nviRHDem2_6	AV	87	lev_percent	81	122	AO	87
nviDisable_6	AV	88	switch	95	130	AO	88
Expansion_6	AV	89	N/A	N/A	N/A	AO	89
Expansion_6	AV	90	N/A	N/A	N/A	AO	90
nvoFault_6	BV	76	switch	95	123	Binary In	76
nvoHWSensor_6	BV	77	switch	95	124	Binary In	77
nvoNetSensor_6	BV	78	switch	95	125	Binary In	78
nvoDisable_6	BV	79	switch	95	126	Binary In	79
nvoSecurity_6	BV	80	switch	95	127	Binary In	80
nvoService_6	BV	81	switch	95	128	Binary In	81
nvoStatus_6	BV	82	switch	95	129	Binary In	82
Expansion_6	BV	83	N/A	N/A	N/A	Binary Out	83
nviNetSensor_6	BV	84	switch	95	131	Binary Out	84
nvoConnection_6	BV	85	switch	95	132	Binary Out	85
Expansion_6	BV	86	N/A	N/A	N/A	Binary Out	86
Expansion_6	BV	87	N/A	N/A	N/A	Binary Out	87
Expansion_6	BV	88	N/A	N/A	N/A	Binary Out	88
Expansion_6	BV	89	N/A	N/A	N/A	Binary Out	89
Expansion_6	BV	90	N/A	N/A	N/A	Binary Out	90

**Table 10. Humidifier Variable Addresses  
Unit #7**

Unit #7	BACnet		Lonworks			N2	
	Type	Instance	SNVT	SNVT #	Element	Type	Instance
nvoHourOpt_7	AV	91	time_hour	124	133	AI	91
nvoCapLimit_7	AV	92	lev_percent	81	134	AI	92
nvoRHDem1_7	AV	93	lev_percent	81	135	AI	93
nvoSet1_7	AV	94	lev_percent	81	136	AI	94
nvoRHDem1_7	AV	95	lev_percent	81	137	AI	95
nvoSet2_7	AV	96	lev_percent	81	138	AI	96
nvoSysDemand_7	AV	97	lev_percent	81	139	AI	97
nviCapLimit_7	AV	98	lev_percent	81	140	AO	98
nviSet1_7	AV	99	lev_percent	81	141	AO	99
nviSet2_7	AV	100	lev_percent	81	142	AO	100
nviRHDem1_7	AV	101	lev_percent	81	143	AO	101
nviRHDem2_7	AV	102	lev_percent	81	144	AO	102
nviDisable_7	AV	103	switch	95	152	AO	103
Expansion_7	AV	104	N/A	N/A	N/A	AO	104
Expansion_7	AV	105	N/A	N/A	N/A	AO	105
nvoFault_7	BV	91	switch	95	145	Binary In	91
nvoHWSensor_7	BV	92	switch	95	146	Binary In	92
nvoNetSensor_7	BV	93	switch	95	147	Binary In	93
nvoDisable_7	BV	94	switch	95	148	Binary In	94
nvoSecurity_7	BV	95	switch	95	149	Binary In	95
nvoService_7	BV	96	switch	95	150	Binary In	96
nvoStatus_7	BV	97	switch	95	151	Binary In	97
Expansion_7	BV	98	N/A	N/A	N/A	Binary Out	98
nviNetSensor_7	BV	99	switch	95	153	Binary Out	99
nvoConnection_7	BV	100	switch	95	154	Binary Out	100
Expansion_7	BV	101	N/A	N/A	N/A	Binary Out	101
Expansion_7	BV	102	N/A	N/A	N/A	Binary Out	102
Expansion_7	BV	103	N/A	N/A	N/A	Binary Out	103
Expansion_7	BV	104	N/A	N/A	N/A	Binary Out	104
Expansion_7	BV	105	N/A	N/A	N/A	Binary Out	105

**Table 11. Humidifier Variable Addresses  
Unit #8**

Unit #8 Variable Name	BACnet		Lonworks			N2	
	Type	Instance	SNVT	SNVT #	Element	Type	Instance
nvoHourOpt_8	AV	106	time_hour	124	155	AI	106
nvoCapLimit_8	AV	107	lev_percent	81	156	AI	107
nvoRHDem1_8	AV	108	lev_percent	81	157	AI	108
nvoSet1_8	AV	109	lev_percent	81	158	AI	109
nvoRHDem1_8	AV	110	lev_percent	81	159	AI	110
nvoSet2_8	AV	111	lev_percent	81	160	AI	111
nvoSysDemand_8	AV	112	lev_percent	81	161	AI	112
nviCapLimit_8	AV	113	lev_percent	81	162	AO	113
nviSet1_8	AV	114	lev_percent	81	163	AO	114
nviSet2_8	AV	115	lev_percent	81	164	AO	115
nviRHDem1_8	AV	116	lev_percent	81	165	AO	116
nviRHDem2_8	AV	117	lev_percent	81	166	AO	117
nviDisable_8	AV	118	switch	95	174	AO	118
Expansion_8	AV	119	N/A	N/A	N/A	AO	119
Expansion_8	AV	120	N/A	N/A	N/A	AO	120
nvoFault_8	BV	106	switch	95	167	Binary In	106
nvoHWSensor_8	BV	107	switch	95	168	Binary In	107
nvoNetSensor_8	BV	108	switch	95	169	Binary In	108
nvoDisable_8	BV	109	switch	95	170	Binary In	109
nvoSecurity_8	BV	110	switch	95	171	Binary In	110
nvoService_8	BV	111	switch	95	172	Binary In	111
nvoStatus_8	BV	112	switch	95	173	Binary In	112
Expansion_8	BV	116	N/A	N/A	N/A	Binary Out	113
nviNetSensor_8	BV	114	switch	95	175	Binary Out	114
nvoConnection_8	BV	115	switch	95	176	Binary Out	115
Expansion_8	BV	116	N/A	N/A	N/A	Binary Out	116
Expansion_8	BV	117	N/A	N/A	N/A	Binary Out	117
Expansion_8	BV	118	N/A	N/A	N/A	Binary Out	118
Expansion_8	BV	119	N/A	N/A	N/A	Binary Out	119
Expansion_8	BV	120	N/A	N/A	N/A	Binary Out	120

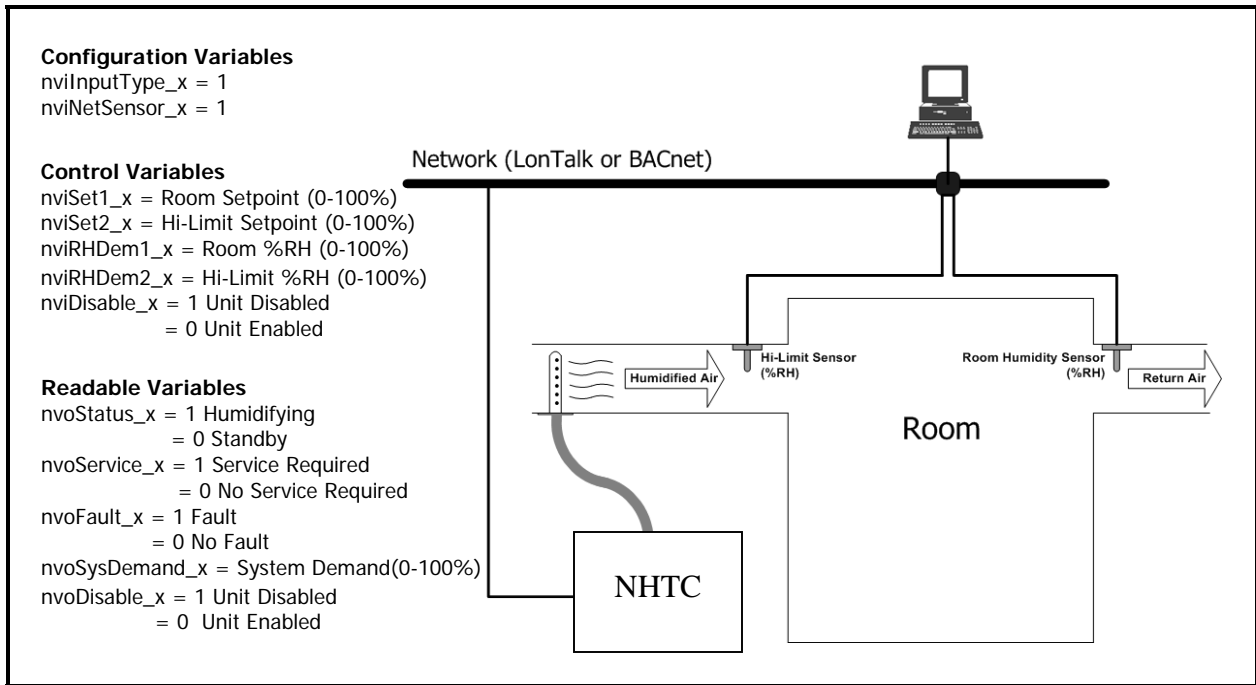

**Figure 1. Sample Humidification Applications  
Room-Sensed %RH Feedback with Duct Hi-Limit Sensing**

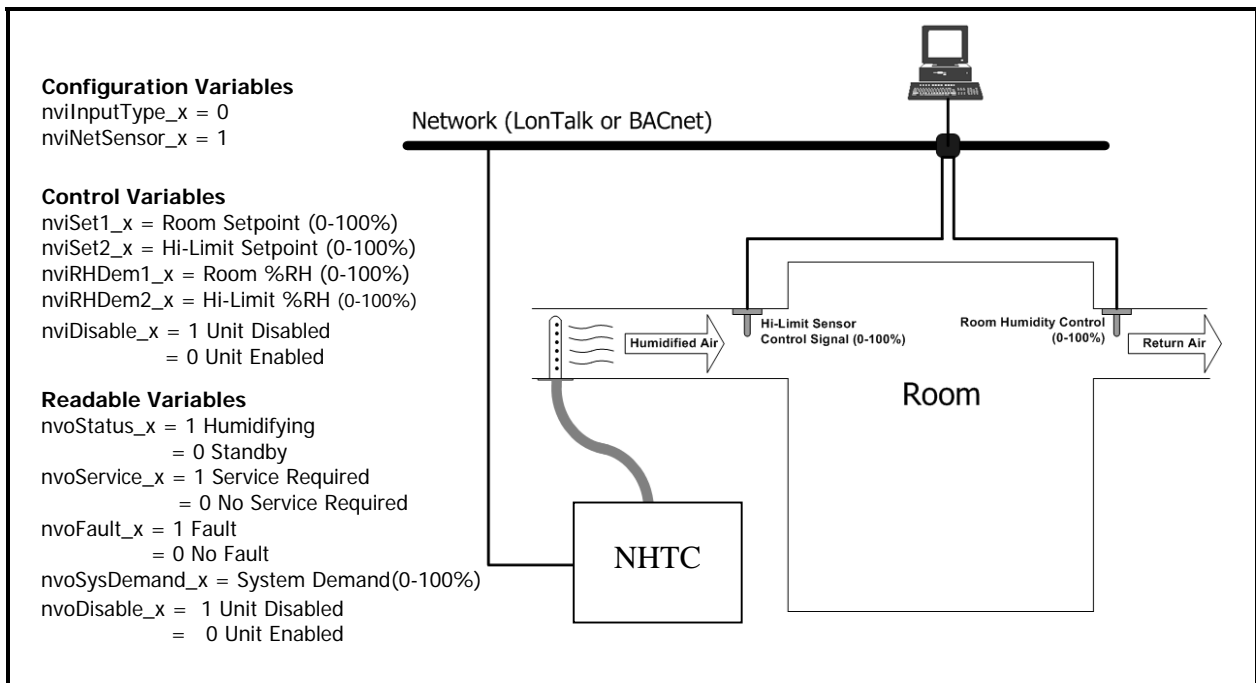

**Figure 2. Sample Humidification Applications  
Control Feedback (0-100%) with Duct Hi-Limit Sensing**

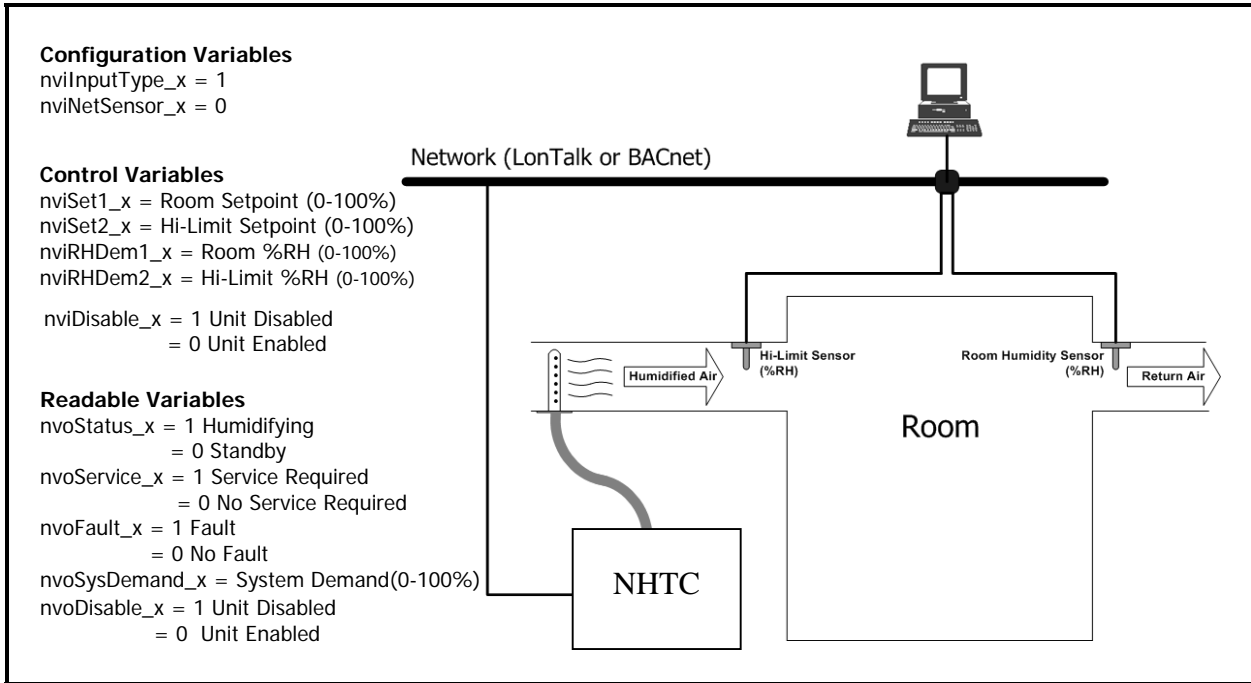

**Figure 3. Sample Humidification Applications**  
**Room-Sensed %RH Feedback with Duct Hi-Limit Sensing (0-10V Signal Directly to Humidifier)**



**THIS PAGE INTENTIONALLY LEFT BLANK**

# 10-20 START-UP

## (1) NORTEC LINKS 2 START-UP CHECKLIST

### WIRING

#### Humidifier-to-Humidifier Connection:

- Each individual humidifier linked to lead unit.
- Connection must be daisy-chained to other units.

#### BMS Network Connection:

- Lead unit wired to BMS system (Twisted Pair or Ethernet).
- Network activity verified.

#### Controls Wired:

- Directly to humidifiers or through BMS network.

## (2) START-UP PROCEDURE

- (1) Ensure power is being supplied to the humidifier, Nortec Links Module and Nortec OnLine module. For BACnet/IP adjust network IP settings. (If this information is provided, factory will perform necessary IP assignment).
- (2) After power-up, verify network communication.
- (3) Map desired network variables to BMS.
- (4) Verify variable operation after mapping is complete.
- (5) Perform regular humidifier start-up check.

# 10-30

# TROUBLESHOOTING

## **(1) TROUBLESHOOTING**

- (1) When troubleshooting the communication process for OnLine and/or LINKS 2 modules should be kept in mind. Humidifier data is first received by the Nortec OnLine module using the modbus protocol over the serial port connection. It then forwards this data, via modbus/TCP, to the LINKS 2 module over an Ethernet link. A router (switch for BACnet/IP applications) links the two devices together through their Ethernet ports and allows a user to access both devices using only 1 customer installed Ethernet line.

## **(2) INDICATOR LIGHTS**

- (1) There is a variety of status LEDs on both the OnLine module and the LINKS 2 module to aid in the diagnosis of communication problems. Note that communication first occurs between the OnLine module and the humidifier logic board. The OnLine module then passes information to the LINKS 2 module. If practical, it may be useful to establish a connection with the Nortec OnLine server first and then establish communication with the LINKS 2 module.

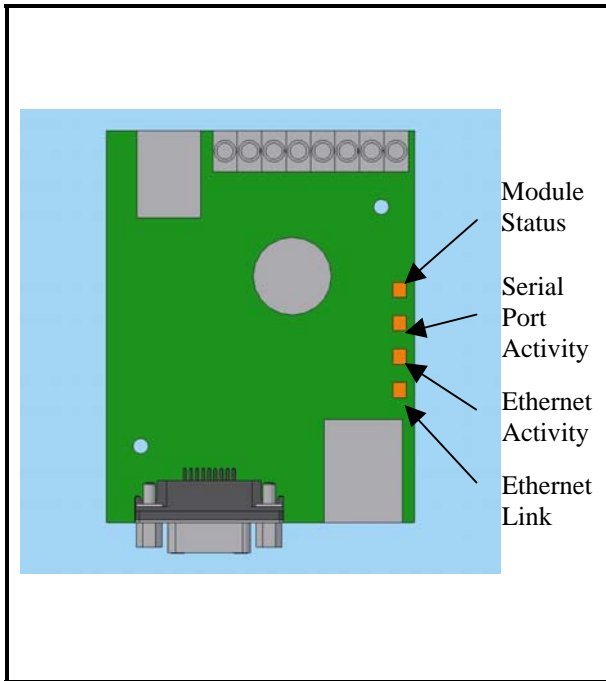

Figure 1. OnLine Diagnostic LED Locations

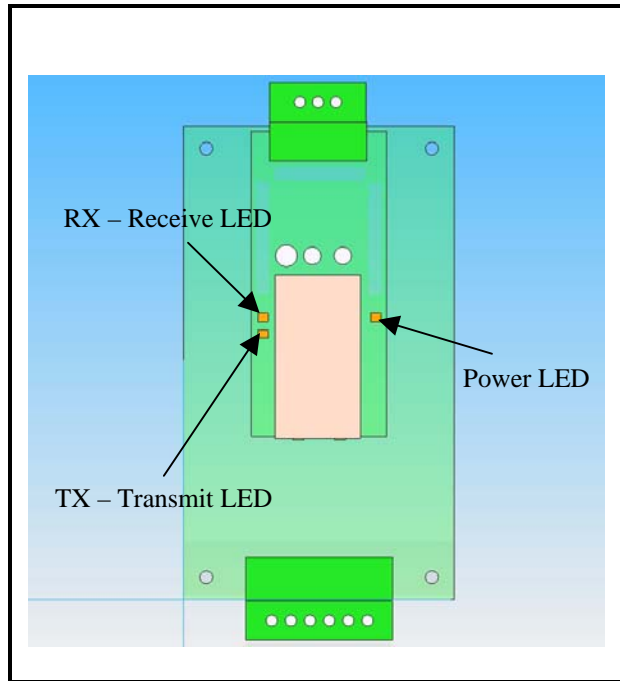

Figure 2. BACnet Module LED

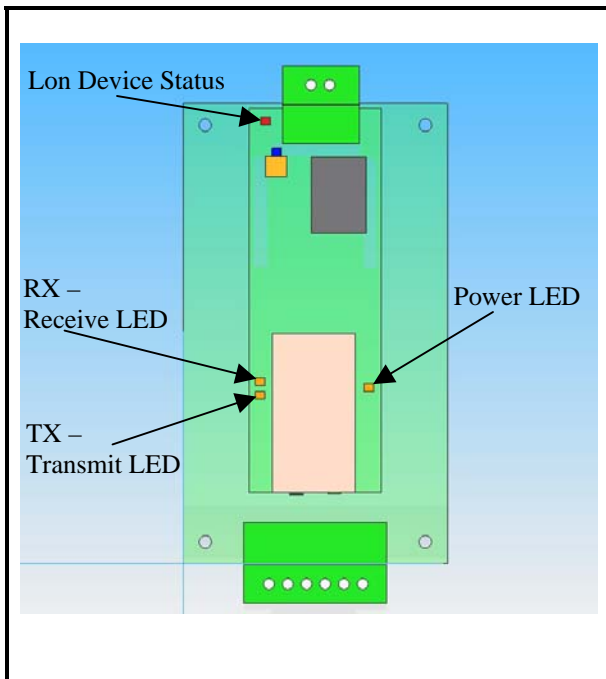

Figure 3. LonWorks Module LED

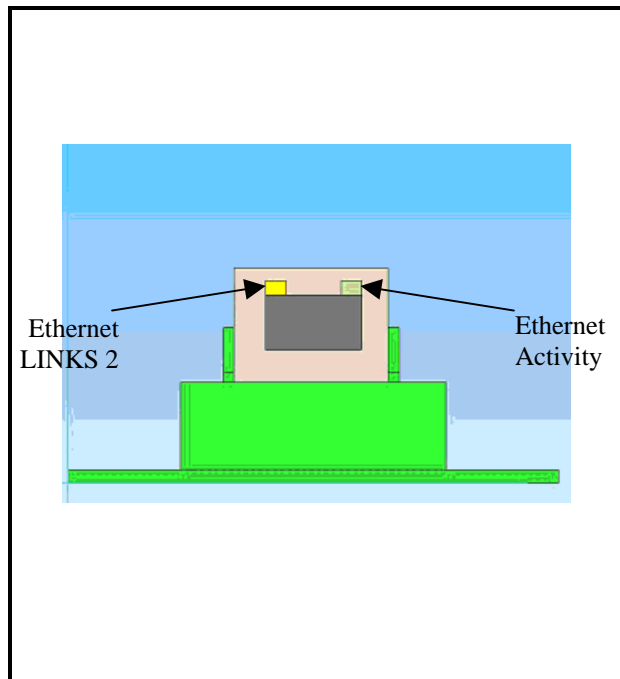

Figure 4. Ethernet Port

**Table 1. OnLine Diagnostic LED Description**

LED Name	Color	Function
Module Status	Off	Indicates that the Online module is not receiving power.
	Green	Indicates the Online module is operating normally.
	Orange	Indicates that the Online module is loading the firmware installed on the module.
Serial Port Activity	Flashing Green	Indicates that the Online module is receiving a network packet from a serial connection.
	Flashing Red	Indicates that the Online module is transmitting a network packet on a serial connection.
	Orange	Displayed when the Online module is booting.
Ethernet Activity/Collision	Flashing Green	Indicates that the Online module is receiving a network packet from an Ethernet connection.
	Flashing Red	Indicates that the Online module is transmitting a network packet on an Ethernet connection.
Ethernet Link	Off	No network connection is present.
	Green	The Online module has detected the presence of a 10Mbps network.
	Orange	The Online module has detected the presence of a 100Mbps network.

**Table 2. LINKS 2 Module Diagnostic LEDs**

<b>LED Name</b>	<b>Color</b>	<b>Function</b>
Module Power	Off	Indicates that the Online module is not receiving power.
	Green	Indicates the Online module is operating normally.
Receive LED (marked as Rx on processor board)	Flashing Green	Indicates that the Online module is receiving a network packet from a serial connection.
Transmit LED (marked as Tx on processor board)	Flashing Green	Indicates that the Online module is transmitting a network packet on a serial connection.
Ethernet LINK	Off	Indicates no Ethernet connection is present.
	Solid Yellow	Indicates an Ethernet connection has been detected.
Ethernet Activity	Off	No Ethernet network activity.
	Flashing Green	Indicates Ethernet activity.



**Table 3. Troubleshooting Communication Problems**

<b>Problem</b>	<b>Solution</b>
<p>1. The BMS network cannot read/write any information to any of the networked humidifiers</p>	<p>Verify that the network connection is made and is connected properly.</p> <p>Verify that the correct network settings are being used. The LINKS 2 module may need to be restarted to load the new settings.</p> <p>Check the Serial Port Activity LED on the Nortec OnLine module to ensure proper communication with the humidifiers. Data is first received from the humidifier to the OnLine module. The OnLine module then transmits this data, via the Ethernet port, to the LINKS 2 module.</p> <p>Check the Ethernet port activity on the LINKS 2 module to ensure it is receiving data from the Nortec OnLine module.</p> <p>Check the transmit and receive status LEDs to determine if there is any network traffic being sent or being received by the LINKS 2 module from the BMS network</p> <p>Verify proper connections to networked humidifiers.</p> <p>Turn the LINKS 2 module and the OnLine module off for several seconds then switch it back on to reload the control program. Allow for some time for the network variables to be polled.</p>
<p>2. The BMS network can see some of the networked humidifiers but not others.</p>	<p>Ensure network variables are mapped correctly to the BMS.</p> <p>Ensure proper connections to the humidifiers.</p> <p>Disconnect all of the humidifiers from the LINKS 2 package except for the unit that is not responding to the network. Turn the LINKS 2 package off and then back on. Check if the humidifier can now be seen by the BMS</p>
<p>3. The BMS network receives information from the networked humidifier(s) but the information is mismatched or the humidifier responds un-expectedly</p>	<p>Verify that the network variables have been mapped to the BMS network correctly. It is possible that the variables have been cross-linked during the network integration process.</p> <p>Connect humidifiers one at a time and test units individually.</p>
<p>4. After sending the humidifier a network-based demand signal the unit powers down after several minutes. The nviNetSensor variable is switched on and a value has been set for the nviRHDem1 variable.</p>	<p>When a BMS network demand/RH signal is being used the network must refresh the nviRHDem signal at least every 5 minutes otherwise the humidifier will revert to a 0 demand state. This is a safety precaution in case the BMS network connection is lost.</p>

# 10-40

# SPARE PARTS

**Table 1. Replacement Parts**

Part Number	Description	Nortec LINKS 2 Options			
		Specify Unit Type Protocol at time of order			
		BACnet/MSTP	BACnet/IP	N2	LonWorks
2527101	LINKS 2 Replacement Module, BACnet/IP		X		
2527102	LINKS 2 Replacement Module, BACnet/MSTP	X			
2527103	LINKS 2 Replacement Module, LonWorks				X
2527104	LINKS 2 Replacement Module, N2			X	
1509604	OnLine Replacement Module, Static/IP	X	X	X	X
2528126	LINKS 2 Replacement Router	X		X	X
2531455	LINKS 2 Ethernet Switch		X		
2530087	24VAV to 9VDC Power Supply (for switch or router)	X	X	X	X

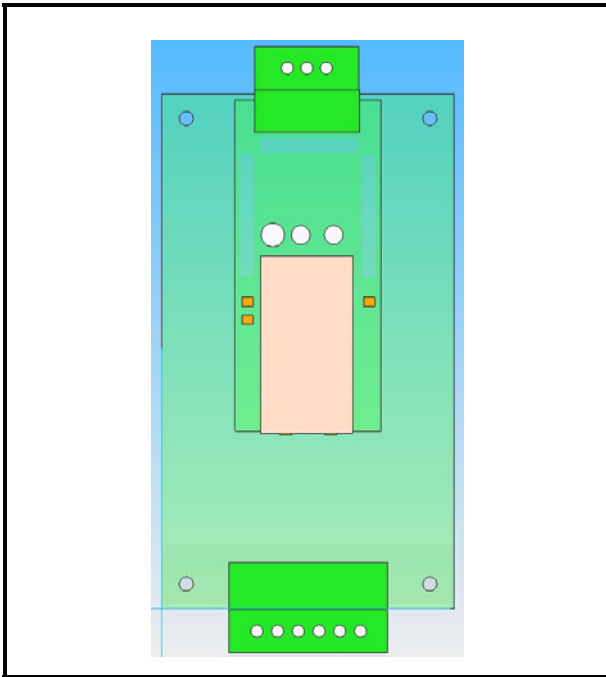

Figure 1. BACnet or N2 Module

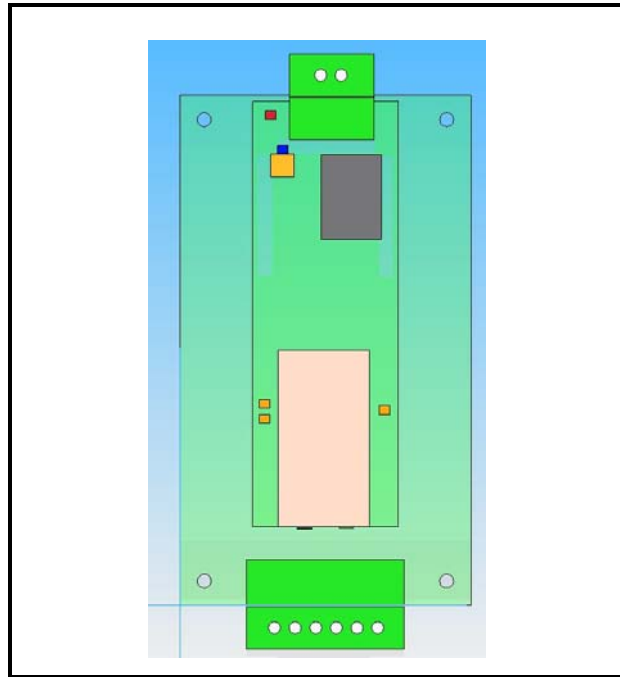

Figure 2. LonWorks Module

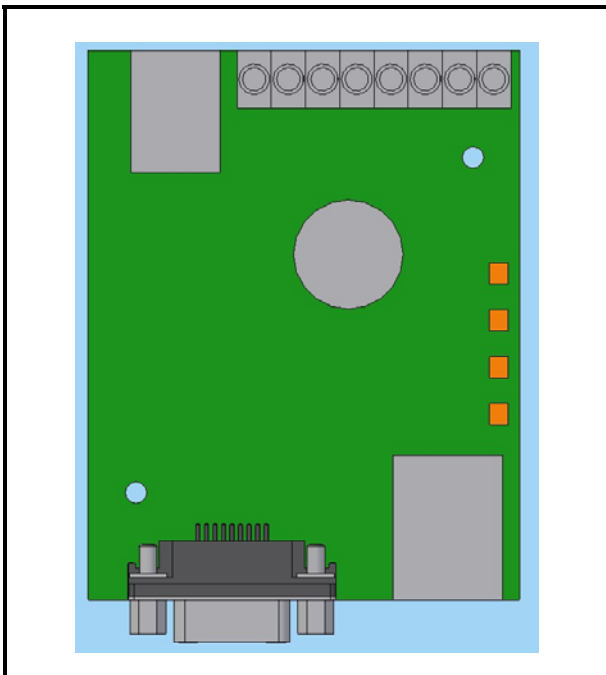

Figure 3. OnLine Module

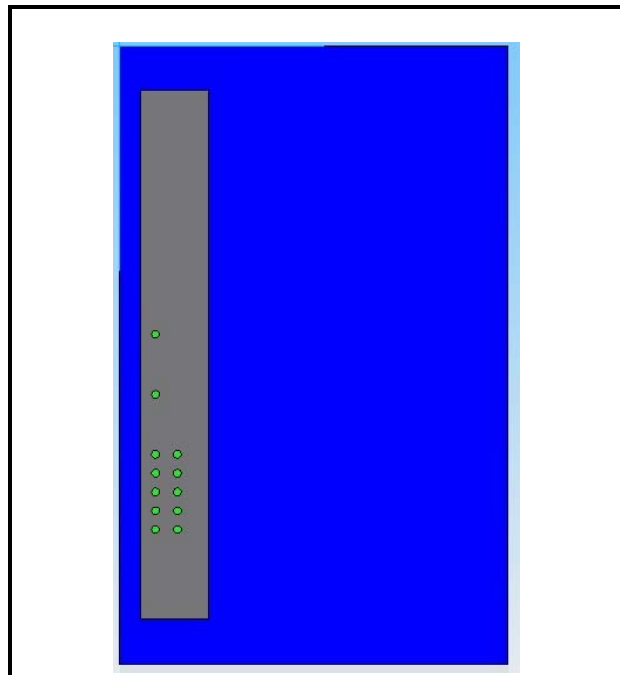

Figure 4. Ethernet Router

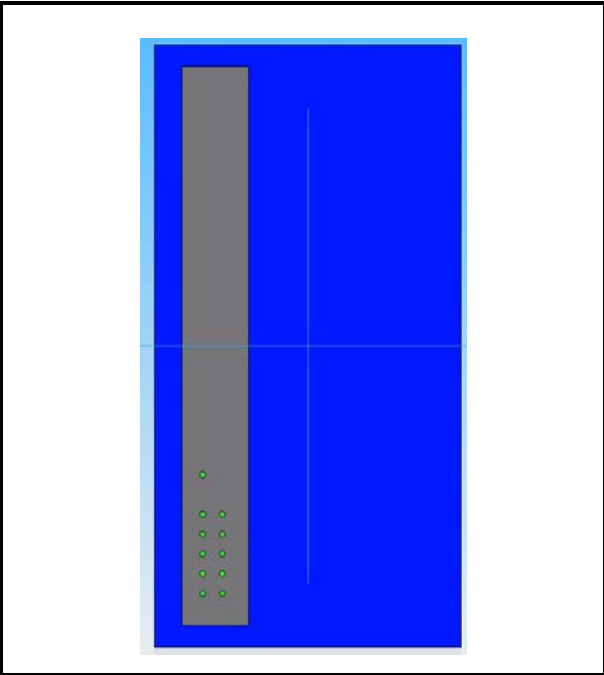
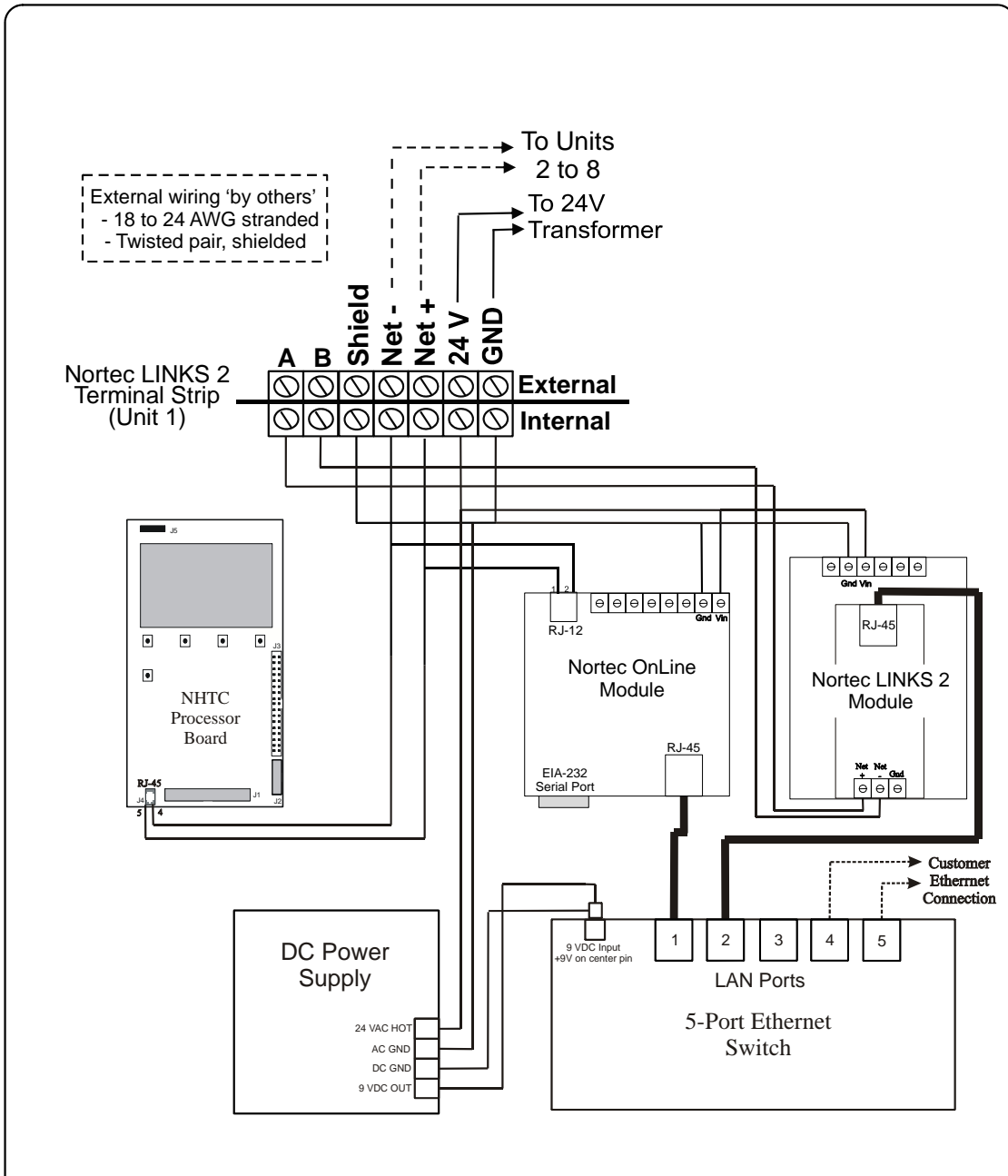

Figure 5. Ethernet Switch

# 10-50 TECHNICAL



**Note:**  
Use open LAN port when employing an internet connection for BACnet/IP and/or Nortec OnLine.

**Figure 1. Wiring Diagram**

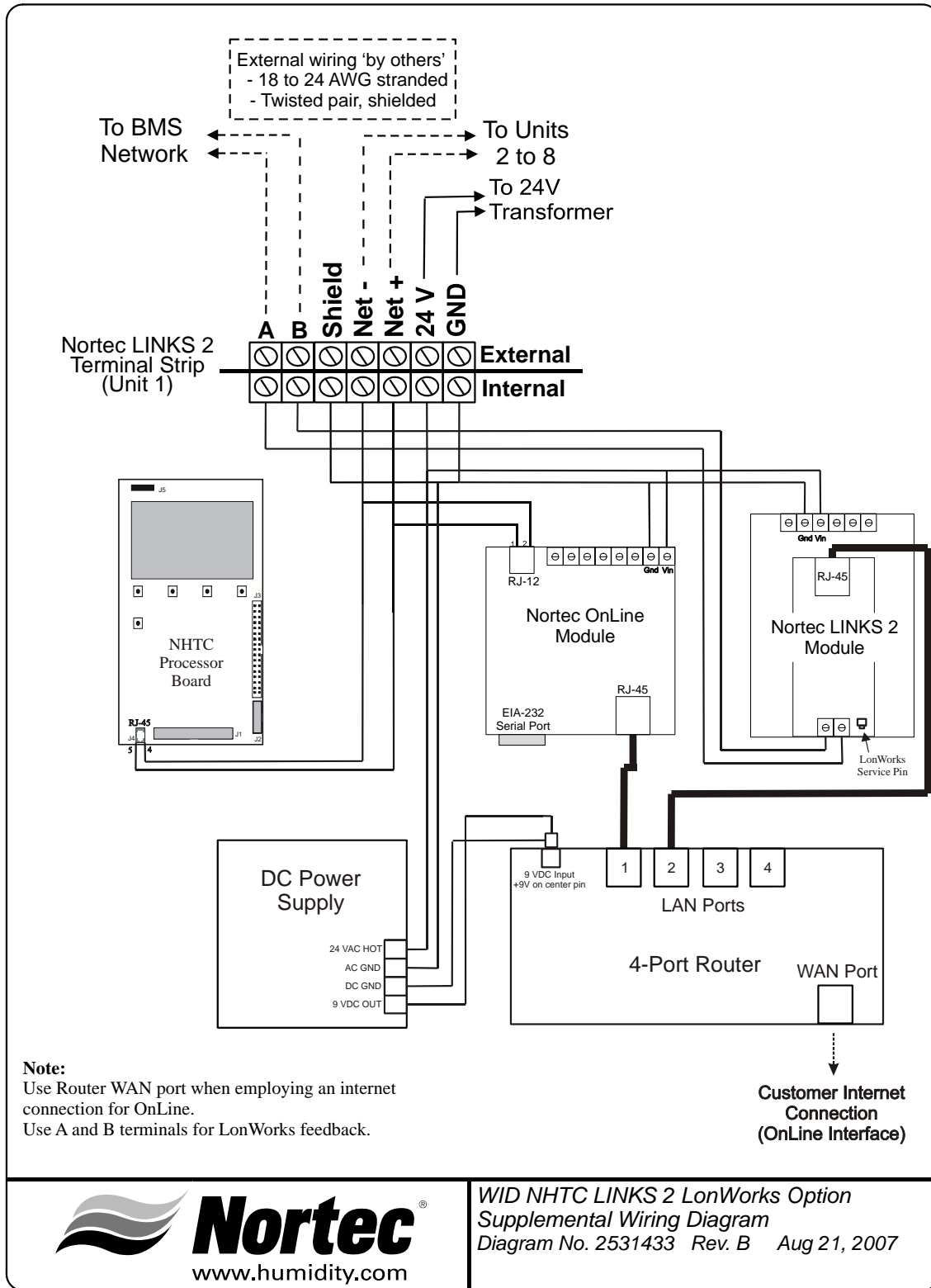

Figure 2. Wiring Diagram



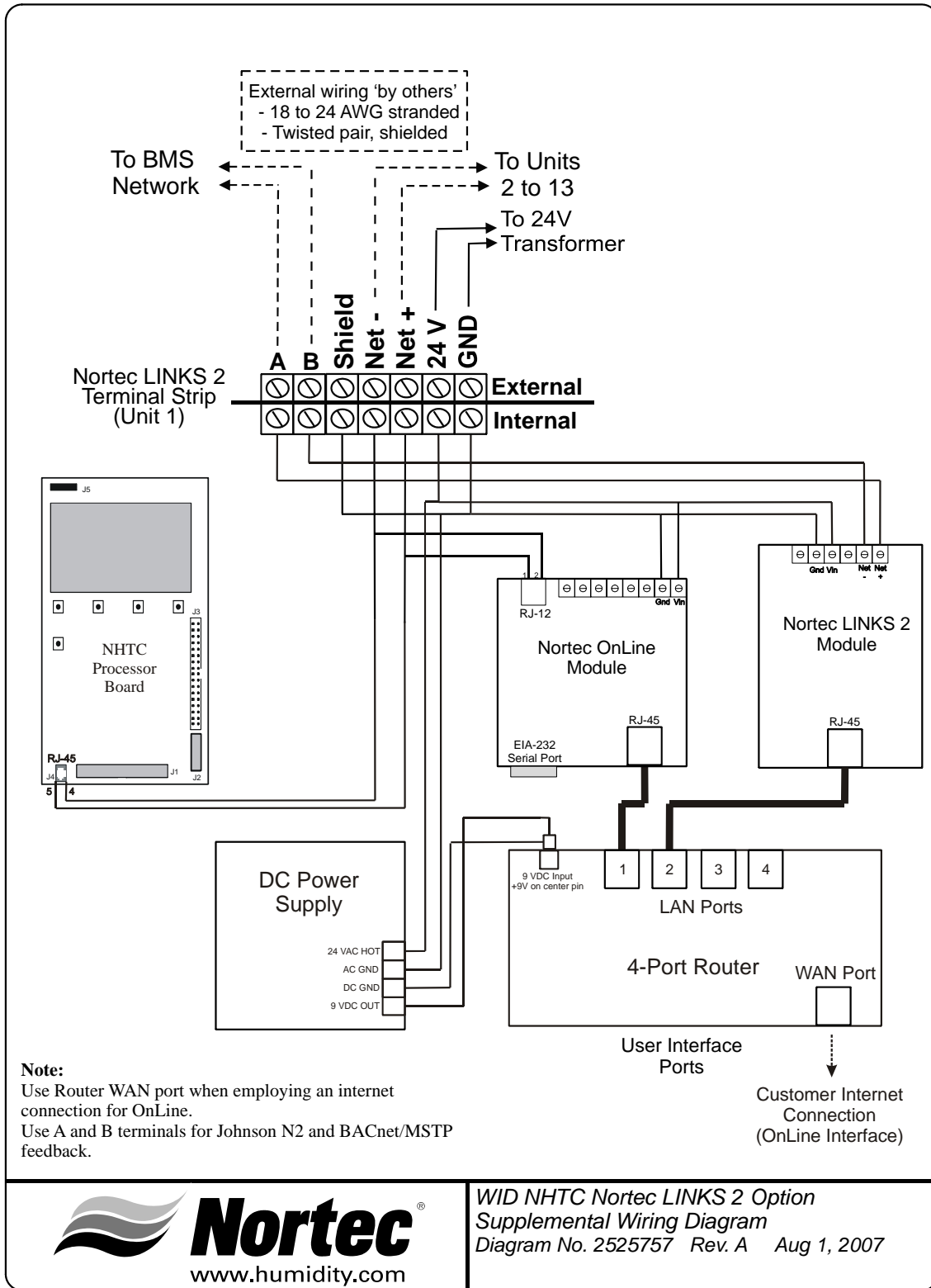

Figure 3. Wiring Diagram

**THIS PAGE INTENTIONALLY LEFT BLANK**

## **WARRANTY**

- (1) WALTER MEIER INC. and/or WALTER MEIER LTD. (hereinafter collectively referred to as THE COMPANY), warrant for a period of two years after installation or 30 months from manufacturer's ship date, whichever date is earlier, that THE COMPANY's manufactured and assembled products, not otherwise expressly warranted (with the exception of the cylinder), are free from defects in material and workmanship. No warranty is made against corrosion, deterioration, or suitability of substituted materials used as a result of compliance with government regulations.
- (2) THE COMPANY's obligations and liabilities under this warranty are limited to furnishing replacement parts to the customer, F.O.B. THE COMPANY's factory, providing the defective part(s) is returned freight prepaid by the customer. Parts used for repairs are warranted for the balance of the term of the warranty on the original humidifier or 90 days, whichever is longer.
- (3) The warranties set forth herein are in lieu of all other warranties expressed or implied by law. No liability whatsoever shall be attached to THE COMPANY until said products have been paid for in full and then said liability shall be limited to the original purchase price for the product. Any further warranty must be in writing, signed by an officer of THE COMPANY.
- (4) THE COMPANY's limited warranty on accessories, not of the companies manufacture, such as controls, humidistats, pumps, etc. is limited to the warranty of the original equipment manufacturer from date of original shipment of humidifier.
- (5) THE COMPANY makes no warranty and assumes no liability unless the equipment is installed in strict accordance with a copy of the catalog and installation manual in effect at the date of purchase and by a contractor approved by THE COMPANY to install such equipment.
- (6) THE COMPANY makes no warranty and assumes no liability whatsoever for consequential damage or damage resulting directly from misapplication, incorrect sizing or lack of proper maintenance of the equipment.
- (7) THE COMPANY retains the right to change the design, specification and performance criteria of its products without notice or obligation.

INSTALLATION DATE (MM/DD/YYYY)

MODEL #

SERIAL #

**walter  
meier**

**U.S.A.**  
**Walter Meier (Climate USA) Inc.**  
826 Proctor Avenue  
Ogdensburg, NY 13669  
TEL: 1-866-NORTEC-1  
EMAIL: northamerica.climate@waltermeier.com  
WEBSITE: www.humidity.com

**CANADA**  
**Walter Meier (Climate Canada) Ltd.**  
2740 Fenton Road  
Ottawa, ON K1T 3T7  
TEL: 1-866-NORTEC-1  
FAX: (613) 822-7964



Certificate No. 002419

**Authorized Agent:**