



STEAM
DISTRIBUTORS
ASD / BSD / CSD

Steam Distribution Installation Manual

IMPORTANT: Read and save this guide for future reference. This guide to be left with equipment owner.

Table Of Contents

INSTALLATION	1
RECEIVING & UNPACKING EQUIPMENT	1
PRE-INSTALLATION.	1
STEAM LINE INSTALLATION	1
GUIDELINES	1
CONDENSATE RETURN GUIDELINES FOR MAIN STEAM LINES	2
DISTRIBUTOR MOUNTING.	3
VERTICAL AIRFLOW	4
HORIZONTAL AIRFLOW	5
VERTICAL AIRFLOW	6
DISTRIBUTOR MOUNTING - HORIZONTAL & VERTICAL FLOW.	7
DISTRIBUTOR MOUNTING.	7
EXPLODED VIEW.	8

INSTALLATION

RECEIVING & UNPACKING EQUIPMENT

1. Check packing slip to ensure ALL material has been delivered.
2. All material shortages are to be reported to Walter Meier (NORTEC) within 48 hours from receipt of goods. Walter Meier (NORTEC) assumes no responsibility for any material shortages beyond this period.
3. Inspect shipping boxes for damage and note on shipping waybill accordingly.
4. After unpacking, inspect equipment for damage and if damage is found, notify the shipper promptly.
5. All NORTEC products are shipped on an F.O.B. factory basis. Any and all damage, breakage or loss claims are to be made directly to the shipping company.
6. Each distributor is provided with: installation manual, one hose cuff, and two hose clamps.

PRE-INSTALLATION CHECK

1. Ensure the total capacity of the humidifier is not higher than the allowable maximum steam capacity of the distributors used.
 ASD 10: 22 lbs/hr (8 kg/hr)
 ASD: 25 lbs/hr (9 kg/hr)
 BSD: 35 lbs/hr (13 kg/hr)
 CSD: 115 lbs/hr (45 kg/hr)

STEAM LINE INSTALLATION

GUIDELINES

1. Nortec steam hose should only be used on short steam runs below 10 feet.
2. Ensure that no condensate produced in the steam line will remain trapped. Steam naturally flows upward and condensate naturally flows downward.
3. See material recommended for use in the chart below. To eliminate the metal corrosion, Nortec does not recommend the use of steel piping.

Chart #1
Steam Line Material

	Steam Hose	Copper Tube	Stainless Steel Tube
Short run < 10 feet (3 m)	✓	✓	✓
Long run > 10 feet (3m)		✓	✓
DI / RO water			✓

4. Consult the following pages for step by step distributor installation starting with Figure #1.
5. Consult the charts below for steam and condensate sizing guidelines when using steam distributors.

Chart #2
Recommended material and size for steam run

Load		Steam Run		Steam Line Material	Steam Line Description
lb/hr	kg/hr	ft	m		
0-30	0-13	0-10	0-3	Copper tube	3/4" MED-L Tubing (7/8" O.D.)
<i>0-30</i>	<i>0-13</i>	<i>10 +</i>	<i>3 +</i>	<i>Copper tube</i>	<i>1" MED-L Tubing (1 1/8" O.D.)</i>
0-30	0-13	0-10	0-3	Stainless Steel tube	7/8" tube x 0.049" thick.
<i>0-30</i>	<i>0-13</i>	<i>10 +</i>	<i>3 +</i>	<i>Stainless Steel tube</i>	<i>1 1/8" tube x 0.049" thick.</i>
30-100	13-45	0-20	0-6	Copper tube	1 1/2" MED-L Tubing (1 5/8" O.D.)
<i>30-100</i>	<i>13-45</i>	<i>20 +</i>	<i>6 +</i>	<i>Copper tube</i>	<i>2" MED-L Tubing (2 1/8" O.D.)</i>
30-100	13-45	0-20	0-6	Stainless Steel tube	1 3/4" tube x 0.065" thick.
<i>30-100</i>	<i>13-45</i>	<i>20 +</i>	<i>6 +</i>	<i>Stainless Steel tube</i>	<i>2" tube x 0.065" thick.</i>

Please note that options shown in ***a bold-italic font*** requires that reducers be used at both ends. These extra large sizes are to allow for better condensation removal in long steam runs. These sizes will not permit you to use hose coupling to connect yourself to either humidifier or distributors.

Chart #3
Recommended Condensate line at distributor(s)

Dispersion Method	Condensate Hose	Copper tube	Stainless Steel tube
1 x Steam distributor	3/8" Nortec 1328840	1/4" MED-L Tubing (3/8" O.D.)	3/8" tube 0.049" thick.
3 x Steam Distributor*	3/8" Nortec 1328840	1/2" MED-L Tubing (7/8" O.D.)	5/8" tube 0.049" thick

*When using more than one distributor, the condensate line should be trapped before joined together.

6. Vertical drop of the drip station should be 1.5 times the diameter of the steam main but no less than 12".
7. At the bottom of this drip station is where the "p-trap" is installed. It is to be 2" larger than the duct static duct pressure.
8. All distributors must be individually trapped.

CONDENSATE RETURN GUIDELINES FOR MAIN STEAM LINES

1. Use vertical condensate leg of distributor only. Do not over-tighten clamp.
2. Drip stations on steam mains must be located at all low points in the system, at each elevation change and or directional change.
3. Horizontal runs of steam must have a 2" rise per foot (10°) when flow is going upwards from drip station and the steam run is to fall 1/2" per foot (2°) when flow is going downwards to drip station.
4. In a horizontal run of the steam main, drip stations must be located at regular intervals of 20 feet.
5. The drip station itself is a section of piping connected to the bottom of the main. A full size tee must be used to create a drip station to allow the condensate to fall in the drip station.

Figure #1
Drain Tee

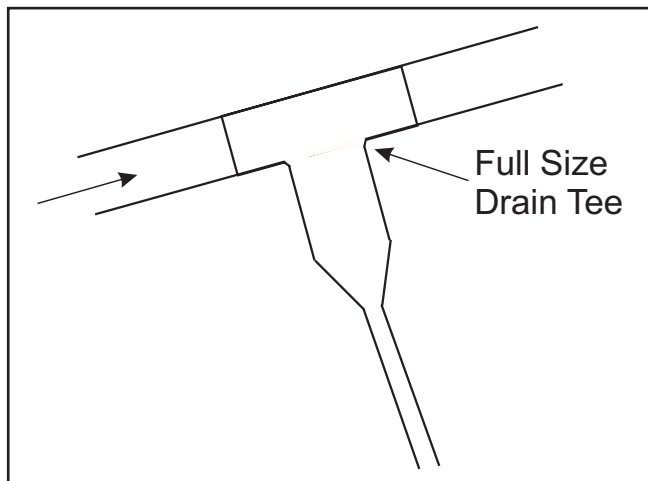
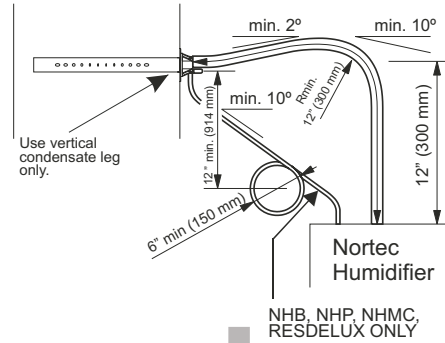
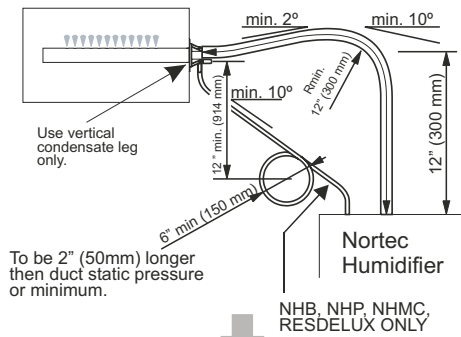

Figure #2
Distributor Mounting

A

HORIZONTAL FLOW

VERTICAL FLOW



GO TO C1

GO TO B

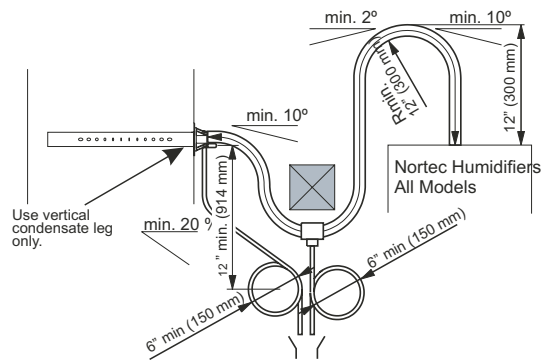
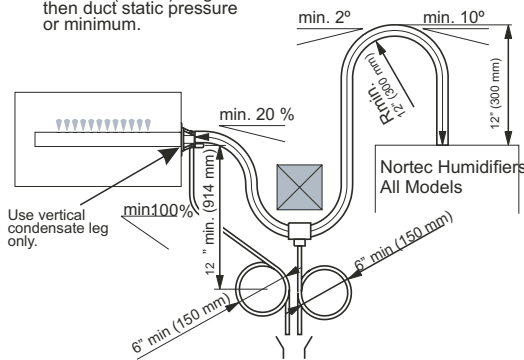
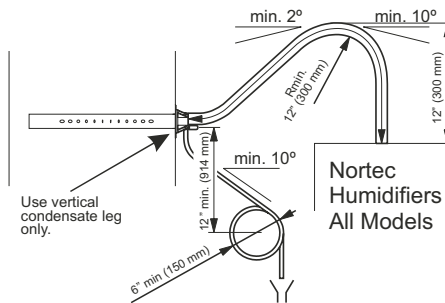
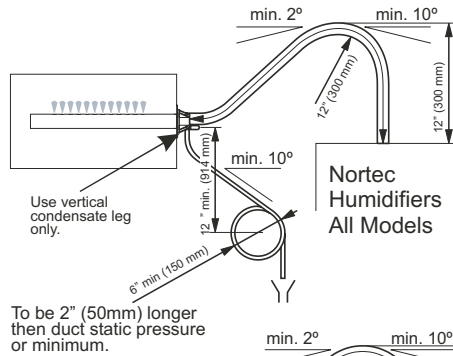

GO TO C1

GO TO B

For long steam runs, condensate trap with full size tee, must be used every 20 feet to eliminate condensate. Follow same rules as above for trap height.

Figure #3
Vertical Airflow

B

Always align distributor holes so that steam is discharged upwards to ensure condensate will remain in the distributor.

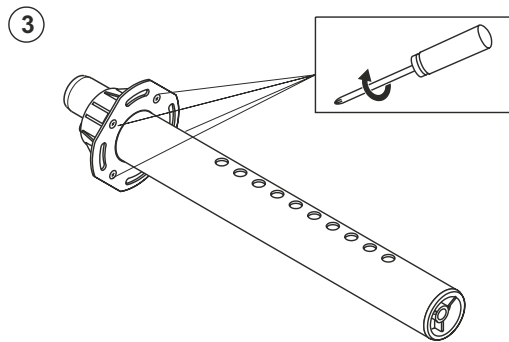
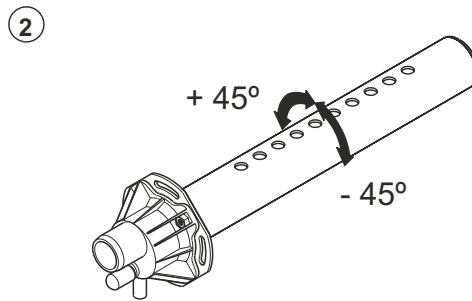
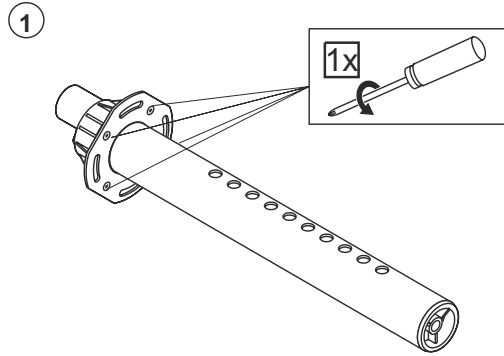

↓
GO TO C2

Figure #4
Horizontal Airflow

C1

Always align distributor holes so that steam is discharged upwards to ensure condensate will remain in the distributor.

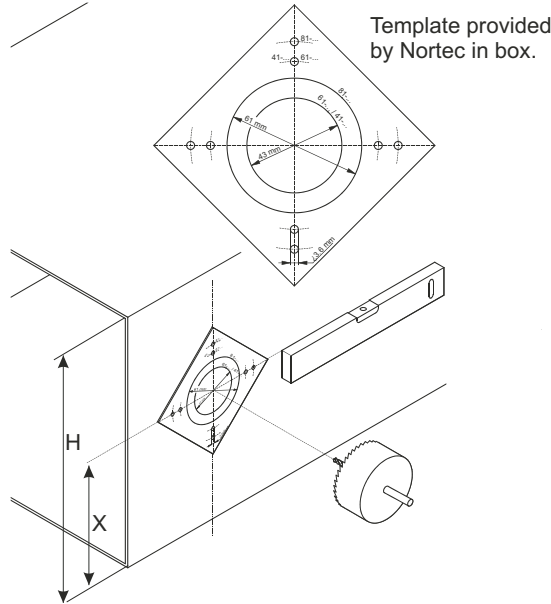

	X Min.	H Min.
ASD	3" (76mm)	8" (203mm)
BSD	4" (102mm)	10" (254 mm)
CSD	5" (127mm)	14" (356mm)

ASD	ø 1.7" (43 mm)
BSD	ø 1.7" (43 mm)
CSD	ø 2.4" (61 mm)

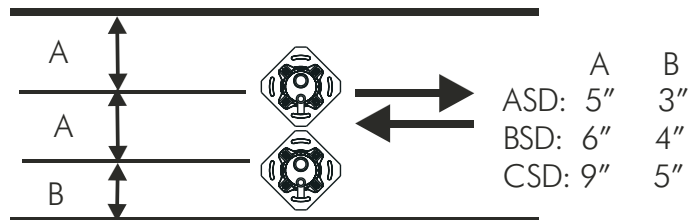
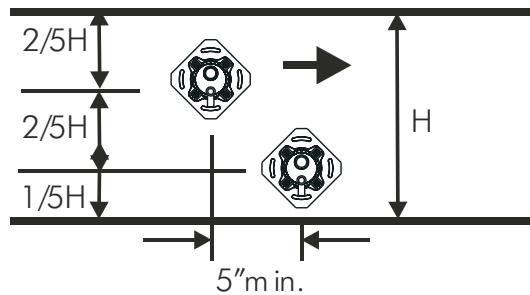
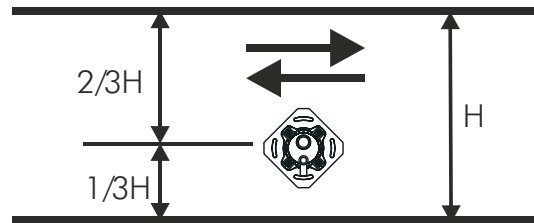

↓
GO TO D

Figure #5
Vertical Airflow

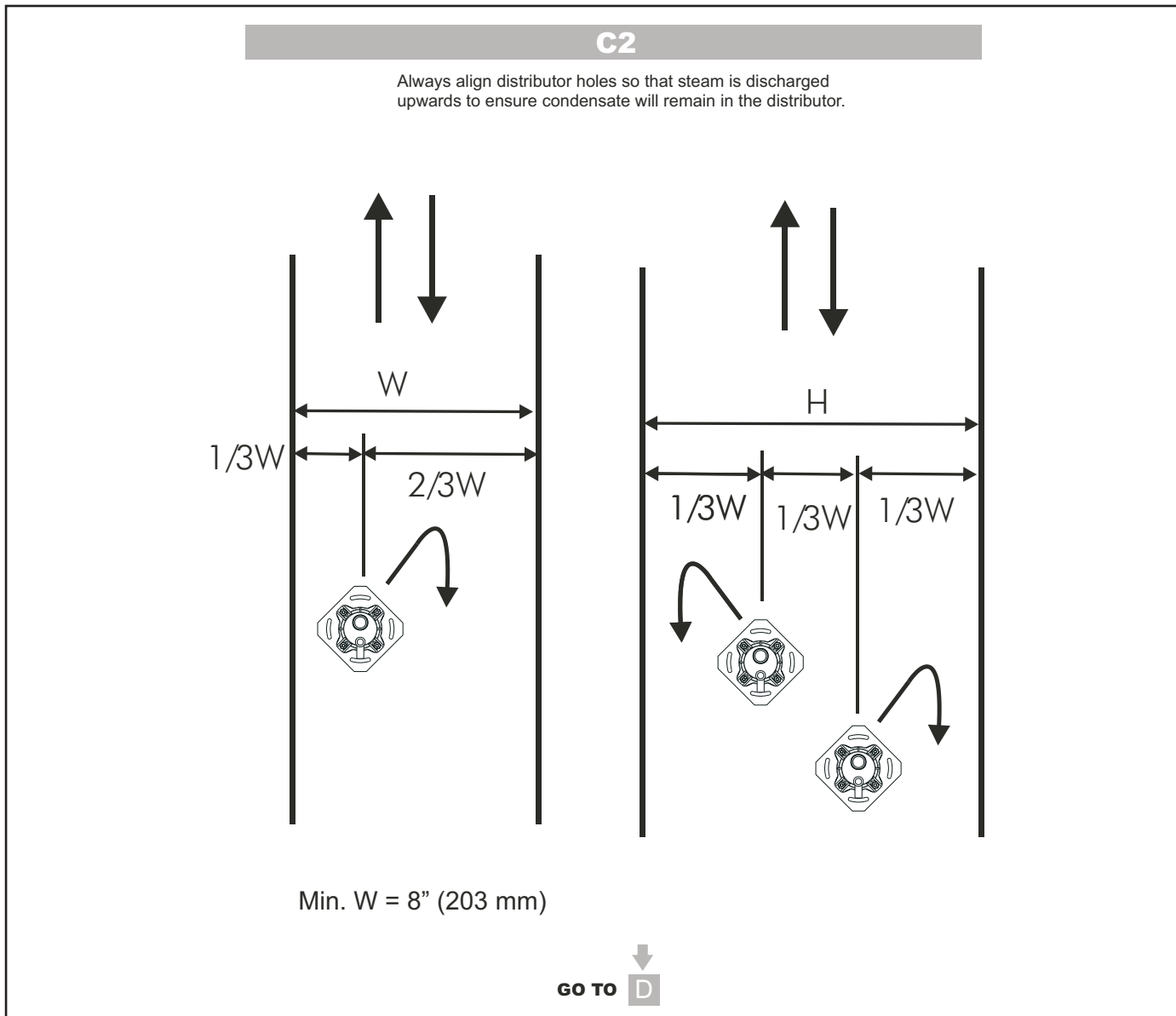

WARNING:

- These installation guidelines apply for duct velocities under 2000 ft/min (610 m/min), please consult factory for higher velocities.
- Please make sure no obstacles (elbow, filter, or diffuser) are located after the distributor in the direction of the airflow closer than the absorption distance calculated for your application.
- Unless you know the exact absorption distance required for the steam absorption into the air stream, the distributor should be located at least 8-10 ft (2-3 m) away from any obstacle it may condense on (elbow, diffuser, filter, etc.).

Figure #6
Distributor Mounting - Horizontal & Vertical Flow

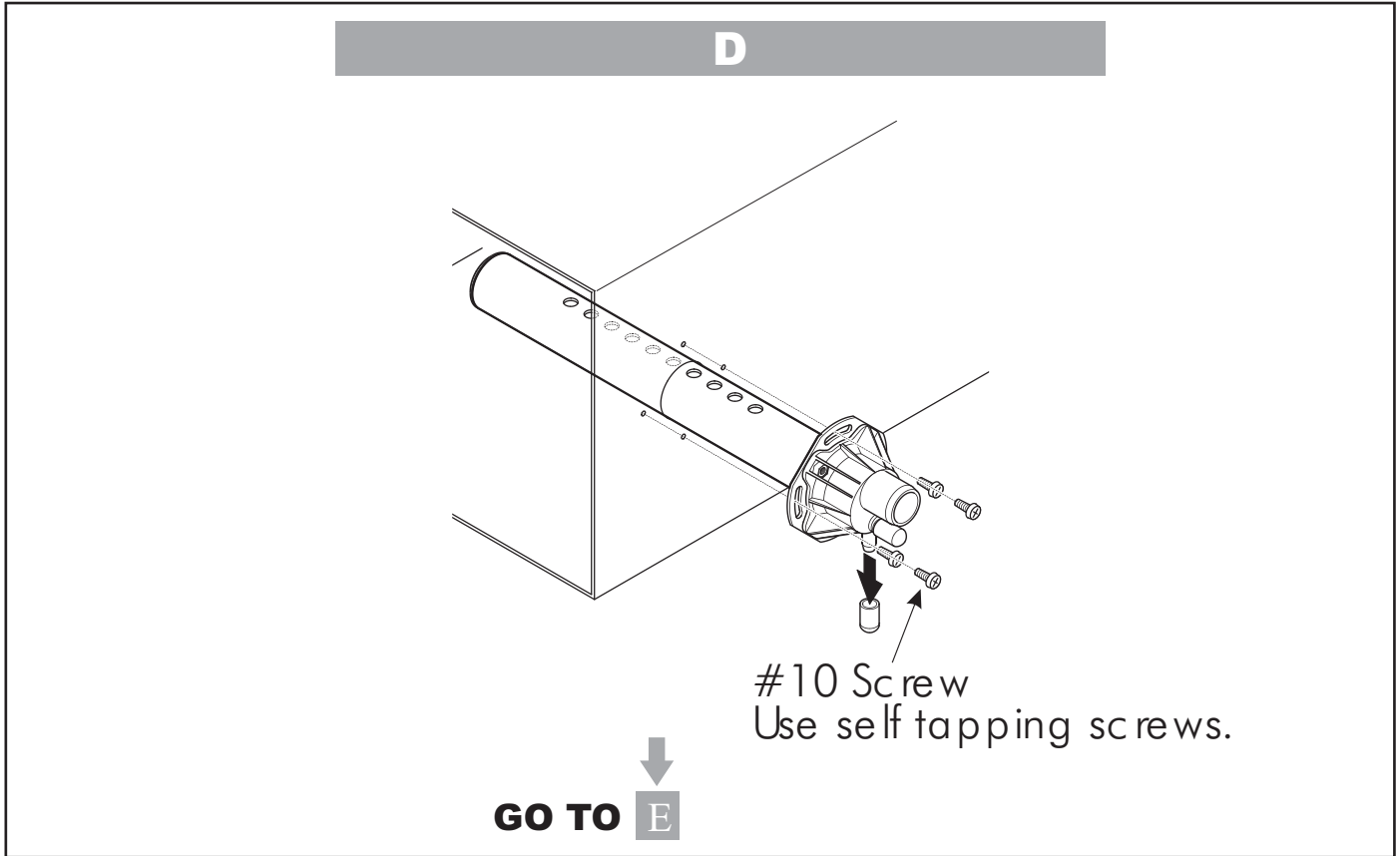
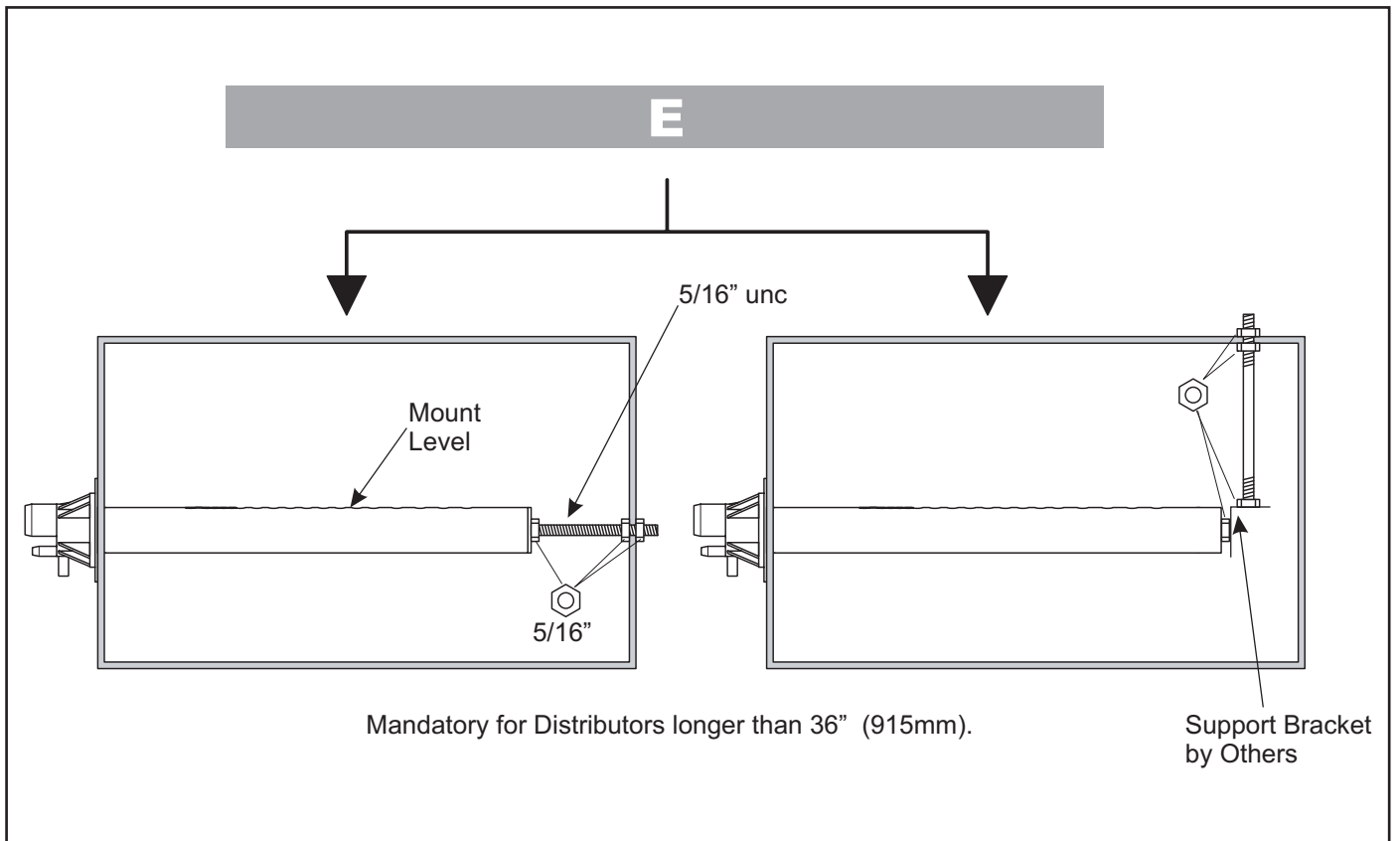

Figure #7
Distributor Mounting



ASD & BSD

1506162- Distributor End Cap Assembly

CSD

1506164 - Distributor End Cap Assembly

Distributor Core

ASD & BSD

1506161- Distributor Inlet Assembly

CSD

1506163 - Distributor Inlet Assembly



Exploded Views
December 18, 2002

LIMITED WARRANTY

Walter Meier Inc. and/or Walter Meier Ltd. (hereinafter collectively referred to as THE COMPANY), warrant for a period of one year from date of shipment, that THE COMPANY's manufactured and assembled products, not otherwise expressly warranted, are free from defects in material and workmanship. No warranty is made against corrosion, deterioration, or suitability of substituted materials used as a result of compliance with government regulations.

THE COMPANY's obligations and liabilities under this warranty are limited to furnishing replacement parts to the customer, F.O.B. THE COMPANY's factory, providing the defective part(s) is returned freight prepaid by the customer. Parts used for repairs are warranted for the balance of the term of the warranty on the original humidifier or 90 days, whichever is longer.

The warranties set forth herein are in lieu of all other warranties expressed or implied by law. No liability whatsoever shall be attached to THE COMPANY until said products have been paid for in full and then said liability shall be limited to the original purchase price for the product. Any further warranty must be in writing, signed by an officer of THE COMPANY.

THE COMPANY's limited warranty on accessories, not of Walter Meier's manufacture, such as controls, humidistats, pumps, etc. is limited to the warranty of the original equipment manufacturer from date of original shipment of humidifier.

THE COMPANY makes no warranty and assumes no liability unless the equipment is installed in strict accordance with a copy of the catalog and installation manual in effect at the date of purchase and by a contractor approved by THE COMPANY to install such equipment.

THE COMPANY makes no warranty and assumes no liability whatsoever for consequential damage or damage resulting directly from misapplication, incorrect sizing or lack of proper maintenance of the equipment.

THE COMPANY retains the right to change the design, specification and performance criteria of its products without notice or obligation.

Walter Meier (Climate USA) Inc.
826 Proctor Avenue, Ogdensburg, New York 13669
Walter Meier (Climate Canada) Ltd.
2740 Fenton Road, Ottawa, Ontario K1T3T7
Tel: 866 NORTEC 1 Fax: 613 822 7964
nortec@humidity.com www.humidity.com

**walter
meier**

PRINTED IN CANADA

