

**Dodge Caliber 2006-
Jeep Compas 2006-
Jeep Patriot 2008-**

Partnr.: CR-034-HH

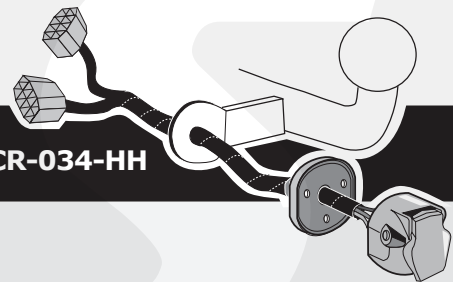

DE Einbauanleitung Elektrosatz Anhängervorrichtung mit 13-P Steckdose lt. DIN/ISO Norm 11446

FR Instructions de montage du faisceau électrique pour crochet d'attelage conforme à la norme DIN/ISO 11446 prise 13-V.

NL Montage-handleiding elektrokabelset voor trekhaak met 13-P contactdoos vlg. DIN/ISO norm 11446.

GB Fitting instructions electric wiring kit tow bar with 13-P socket up to DIN/ISO Norm 11446.

ES Instrucciones de montaje de kit eléctrico para enganche de remolque con caja de conexiones 13-P según norma DIN/ISO 11446.

IT Istruzioni di montaggio di set di cavi elettrici per gancio da traino con zoccolo a 13-P conforme alla norma DIN/ISO 11446.

SE Monteringsanvisningar elkabelsats för dragkrok med 13-P kontaktdosa enligt DIN/ISO norm 11446.

CZ Montážní pokyny: souprava pro elektrické propojení tažné tyče s 13-P zásuvkou do normy DIN/ISO 11446.

DK Monteringsvejledninger for det elektriske ledningsføringssæt for trækstang med 13-N stikdåse, DIN/ISO, norm 11446.

FI Ohjeet vetokoukun sähkökaapelisarjan asentamiseen, jossa on DIN/ISO 11446 mukainen 13-N liitin.

GR Οδηγίες συναρμολόγησης ηλεκτρικού σετ καλωδίων μπάρας ρυμούλκησης με υποδοχή 13-P μέχρι DIN/ISO Κανόνας 11446.

NO Monteringsanviser elkabelsett for trekrok med 13-P koblingsboks ifølge DIN/ISO norm 11446.

PL Instrukcje montażu zestawu okablowania elektrycznego dyszla holowniczego z 13-stykowym gniazdem DIN/ISO 11446.

DE - Wir weisen ausdrücklich darauf hin, dass eine unsachgemäße und nicht in einer Fachwerkstatt durchgeführte Montage einen Verzicht auf Entschädigung jeglicher Art insbesondere bezüglich des Produkthaftpflichtrechts zur Folge hat

FR - Il est expressément prévu qu' on ne saurait se prévaloir d'un quelconque préjudice contractuel ou rédhibitoire si le montage avait été fait en dépit des dites instructions ou dans un garage ne disposant pas des équipements adéquats.

NL - Wij wijzen er met nadruk op, dat ondeskundige en niet door een vakkundige werkplaats uitgevoerde montage tot gevolg heeft dat daardoor ieder recht op schadevergoeding, ook op wettelijke aansprakelijkheid inzake producten, vervalt.

GB - We would expressly point out that assembly not carried out properly by a competent installer will result in cancellation of any right to damage compensation, in particular those arising by virtue of the product liability act.

ES - El montaje inapropiado y efectuado por personal no cualificado originará la pérdida de todo derecho a indemnización o la expiración de toda responsabilidad civil con respecto al producto.

IT - Sottolineiamo espressamente che un montaggio inadeguato ed eseguito da un'officina non specializzata ha come conseguenza il decadere di qualsiasi diritto al risarcimento danni, nonché alla responsabilità legale relativa ai prodotti.

SE - Vi påpekar med eftertryck att all rätt till skadeersättning och all laglig ansvarighet förfaller om monteringen inte har utförts på rätt sätt och av en professionell verkstad.

CZ - Výslovně zdůrazňujeme, že jakákoli montáž, která není provedená ve specializované dílně, má za následek odvolání nároků na kompenzaci jakéhokoliv druhu, obzvláště vyplývajících ze zákona o odpovědnosti za způsobené škody.

DK - Vi ønsker at gøre udtrykkeligt opmærksom på at forkert samling, der ikke er udført af et specialiseret værksted, resulterer i bortfaldelse af kompenseringskrav af alle slags, i særdeles krav der måtte opstå omkring det lovpligtige ansvar.

FI - Korostamme, että kaikki oikeudet vahinkokorvaukseen kuten myös valmistajan laillinen vastuu raukeavatt, mikäli asennusta ei ole toteutettu oikealla tavalla eikä ammattitaitoisen asiantuntijan toimesta.

GR - Επισημαίνουμε κατηγορηματικά ότι οποιαδήποτε εσφαλμένη συναρμολόγηση, η οποία δεν έχει πραγματοποιηθεί ειδικό εργαστήριο θα οδηγήσει σε αποποίηση των αξιώνων επιβολής αποζημιώσεων οποιαδήποτε είδους, ειδικά όσα προκύπτουν από το νόμο ευθύνης προϊόντων.

NO - Vi påpeker ettertrykkelig at all rett til skadeerstatning og rettslig ansvar forfaller dersom monteringen ikke er blitt utført på riktig måte og av et profesjonelt verksted.

PL - Chcielibyśmy wyraźnie zaznaczyć, iż wszelki nieprawidłowy montaż, który nie jest wykonywany w specjalistycznym warsztacie pociąga za sobą utratę możliwości dochodzenia wszelkiego typu roszczeń, w szczególności tych wynikających z odpowiedzialności producenta za swój produkt.

- Technische Änderungen vorbehalten.

- Widerstand nur gemäß der Tabelle auf dem Anhänger verwenden, siehe Seite 13.

- Sous réserve de modifications techniques.

- Ne excédez pas la charge maximale, indiquée dans le tableau sur page 13.

- Technische wijzigingen voorbehouden.

- Gebruik alleen belasting volgens aansluittabel op het getrokken voertuig, zie pagina 13.

- Contents of these kits and their fitting manuals are subject to alteration without notice, please ensure that these instructions are read and fully understood before commencing installation.

- Do not overload circuits; the maximum loads per connection are detailed in this manual.

- Nos reservamos el derecho a efectuar modificaciones técnicas.

- Utilice sólo cargas de acuerdo a la tabla de conexión del vehículo remolcado (ver página 13).

- Ci si riserva il diritto di apportare modifiche tecniche.

- Utilizzare esclusivamente un carico conforme alla tabella degli allacci relativa al veicolo in questione, cfr. pagina 13.

- Tekniska ändringar förbehålles.

- Använd endast belastning enligt anslutningstabellen på det dragna fordonet, se sid. 13.

- Změny mohou být provedeny bez oznámení.

- Používejte pouze při maximálním nabití podle tabulky na tažném vozidle, viz. str. .

- Kan ændres uden varsel.

- Brug kun den maksimale belastning, i overensstemmelse med forbindelsestabelen for bugserede køretøjer, side 13.

- Oikeus teknisiin muutoksiin ilman erillistä huomautusta pidätetään.

- Kuormita työvirtapiiriä ainoastaan hinattavan ajoneuvon kytkentäkaavion mukaisesti, katso sivu 13.

- Μπορεί να τροποποιηθεί χωρίς προηγούμενη ειδοποίηση.

- Χρησιμοποιείτε μόνο μέγιστο ηλεκτρικό φορτίο σύμφωνα με τον πίνακα σύνδεσης στο ρυμούλκούμενο όχημα, δείτε σελίδα 13.

- Tekniske endringer forbeholdes. - Overskrid ikke grensene anviset i tilkoblingstabellen på tilhengeren eller det tilkoblede kjøretøyet, se s. 13.

- Podlega zmianom bez powiadomienia.

- Używać tylko takiego maksymalnego obciążenia które wynika z tabliczki połączeń holowanego pojazdu, patrz strona 13.

Einzelteilliste

Liste de pièces

Onderdelenlijst

Part list

Lista de componentes

Elenco componenti

Dellista

Seznam dílů

Del-liste

Osaluettelo

Κατάλογος εξαρτημάτων

Delliste

Lista części

DE

FR

NL

GB

ES

IT

SE

CZ

DK

FI

GR

NO

PL

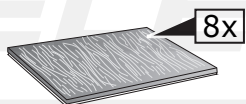
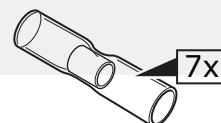
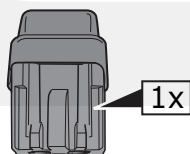
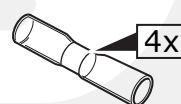
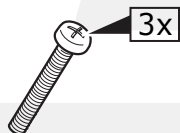
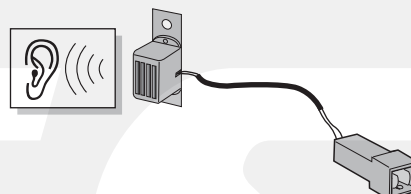
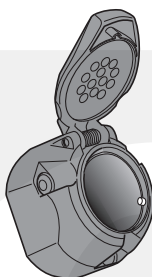
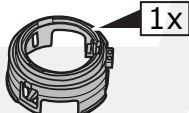
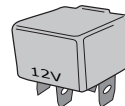
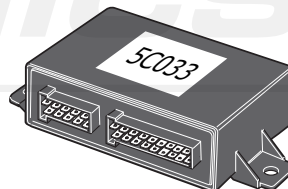
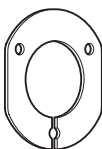
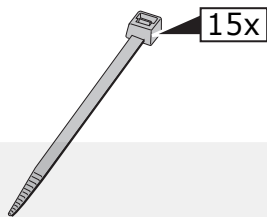
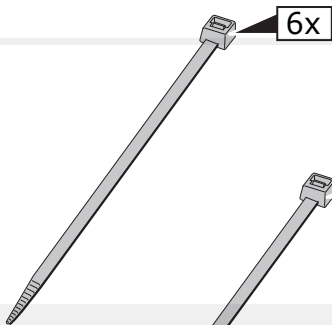
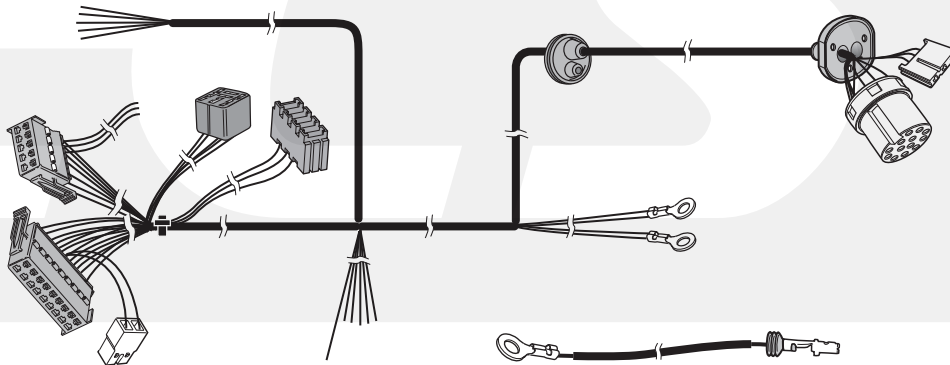
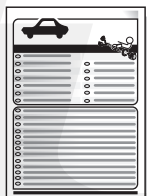
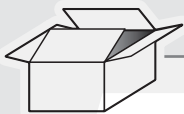

1

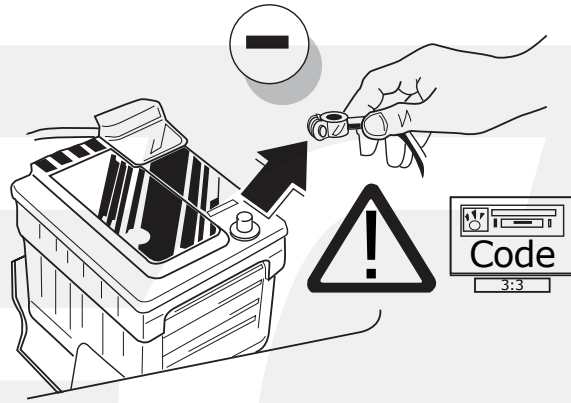

2

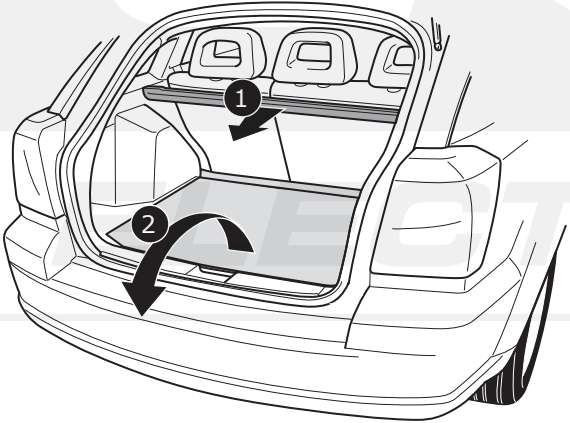

3

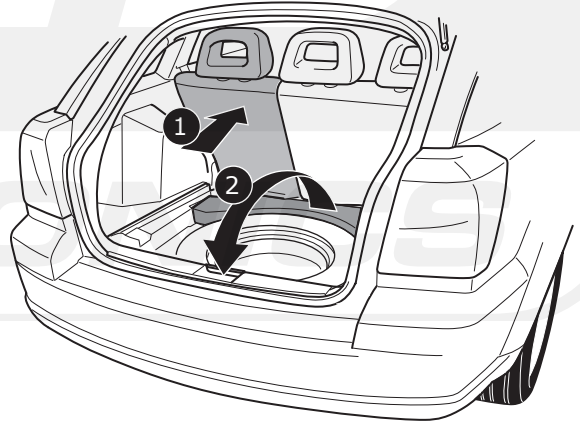

4

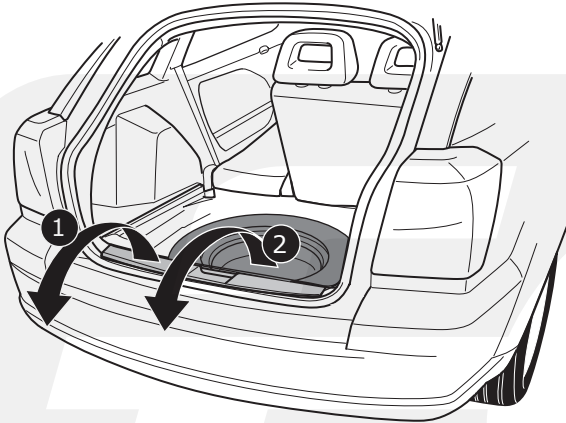

5

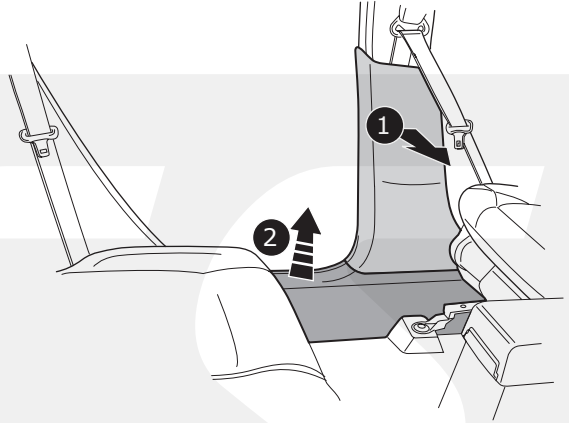

6

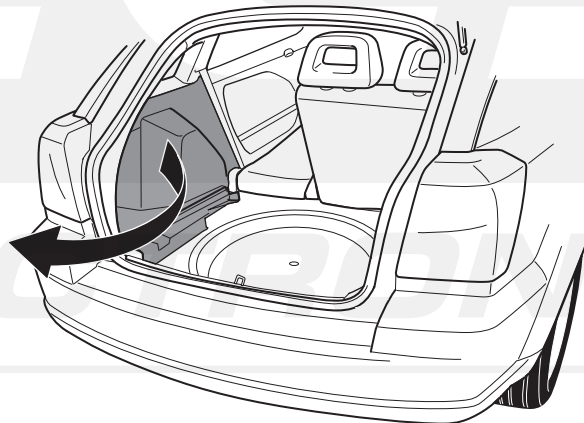

INFO

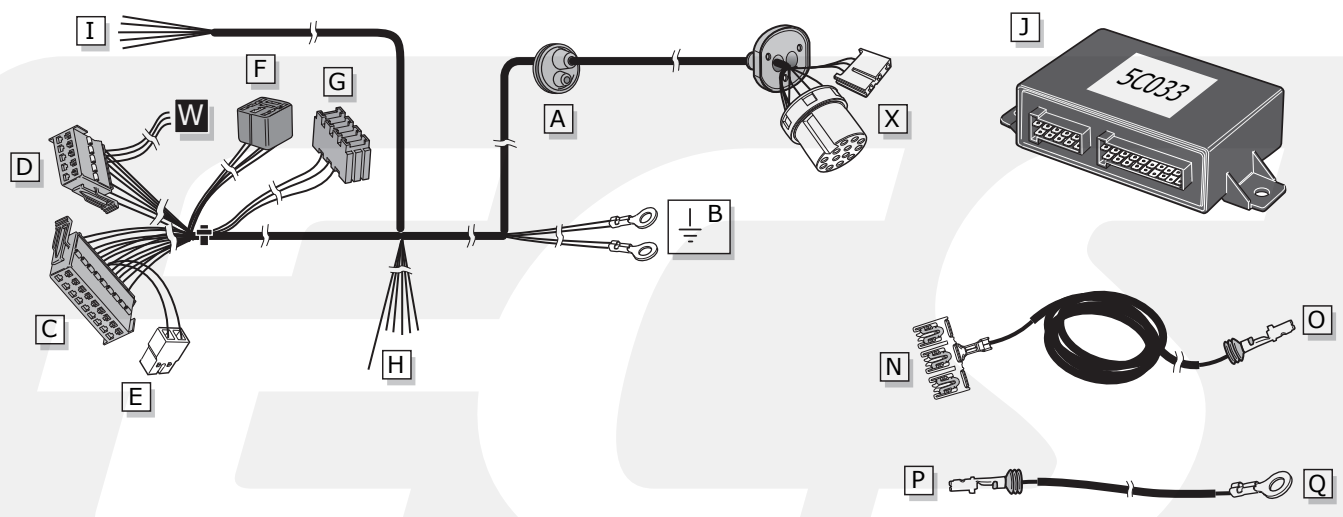

Option! **W**

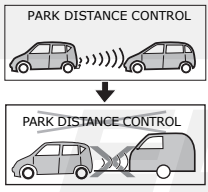

Pag. 12

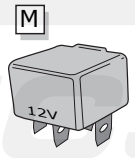
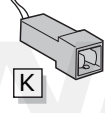

R

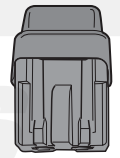

ROUTING

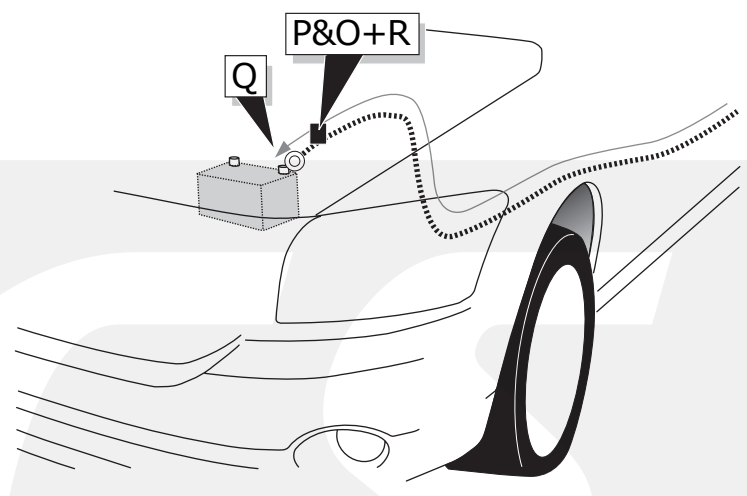
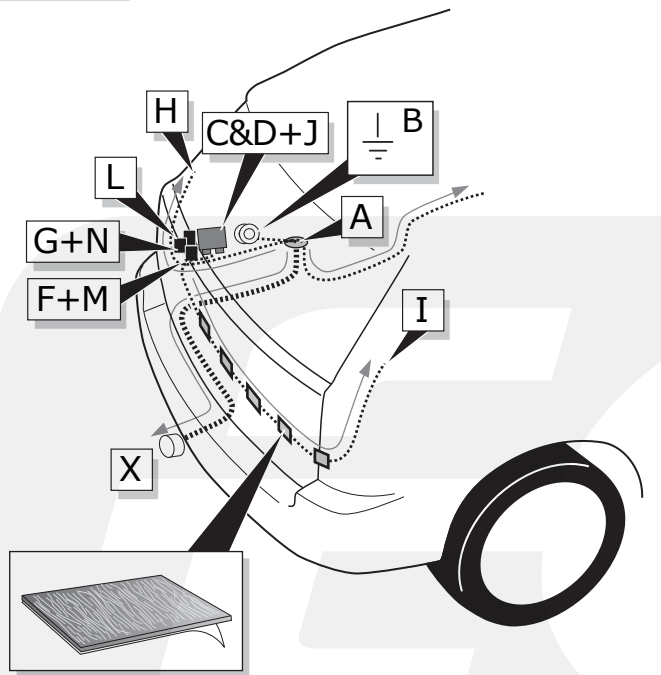

7

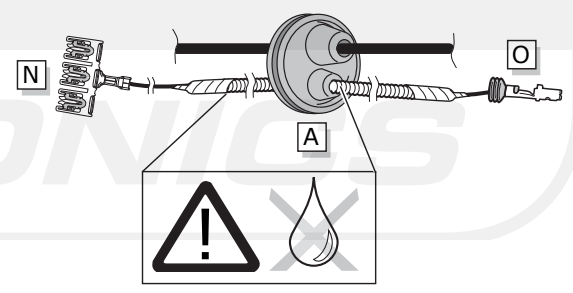
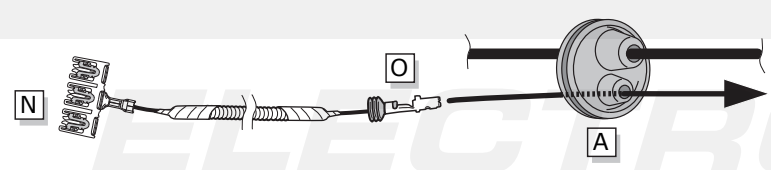

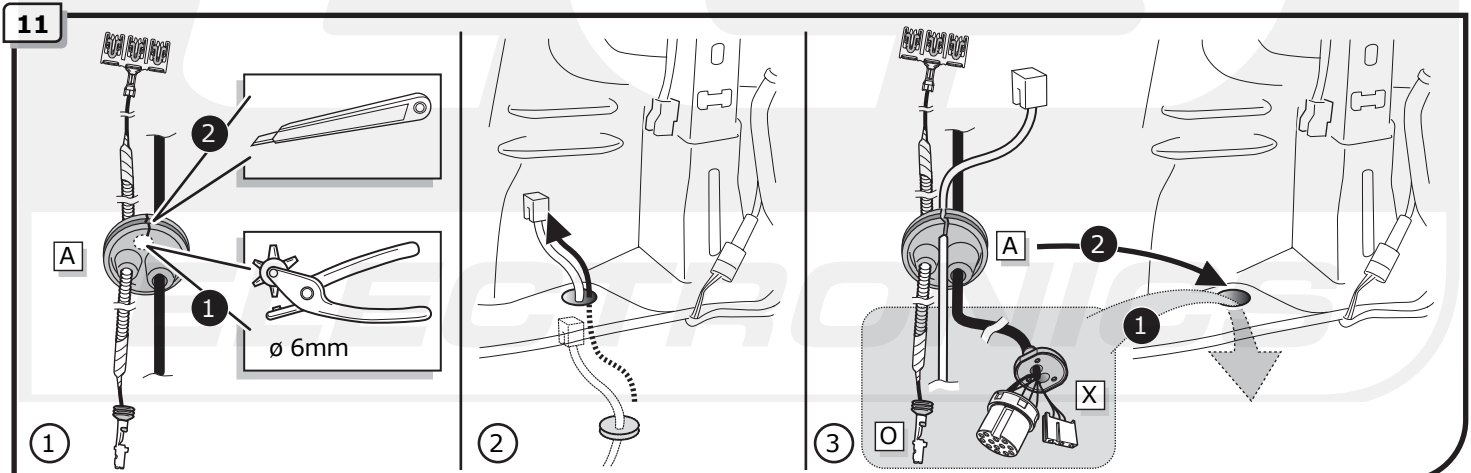
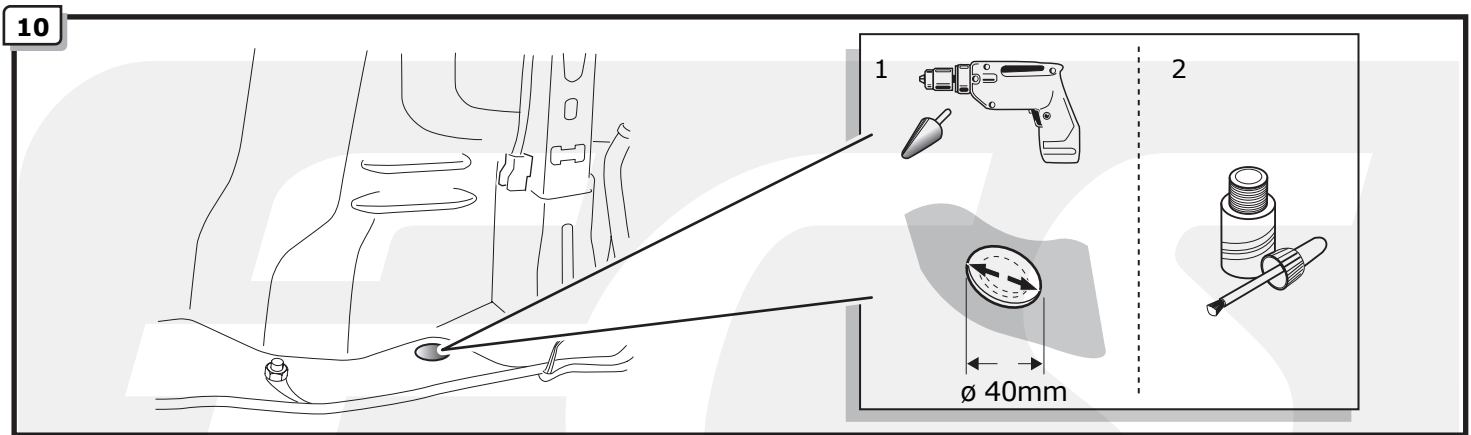
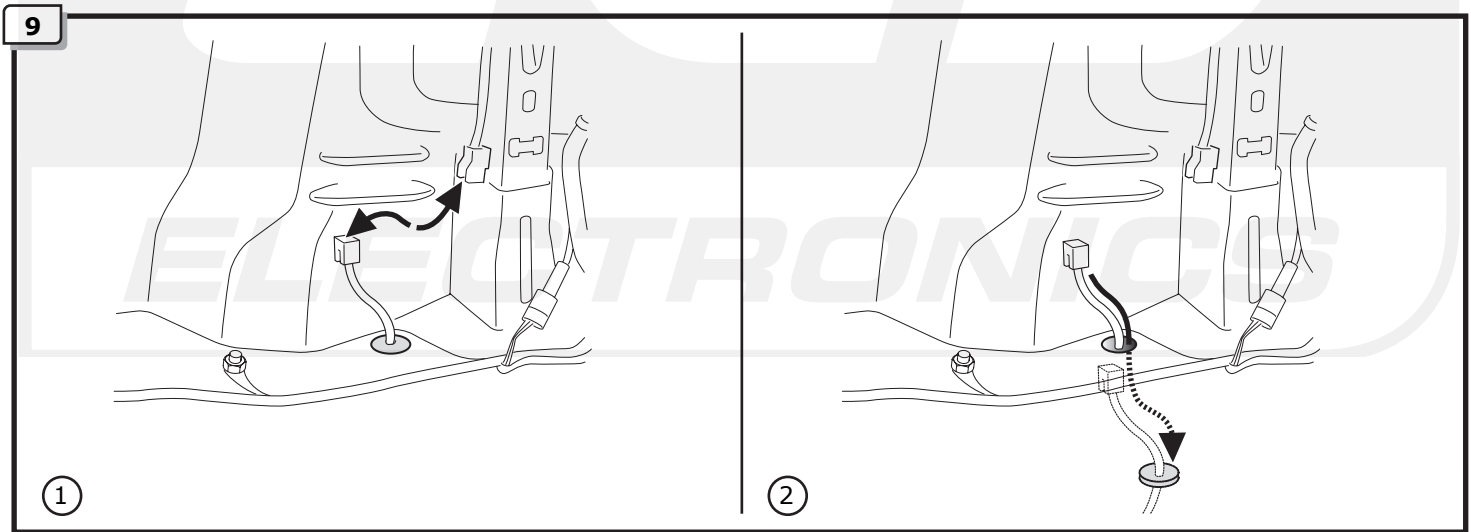
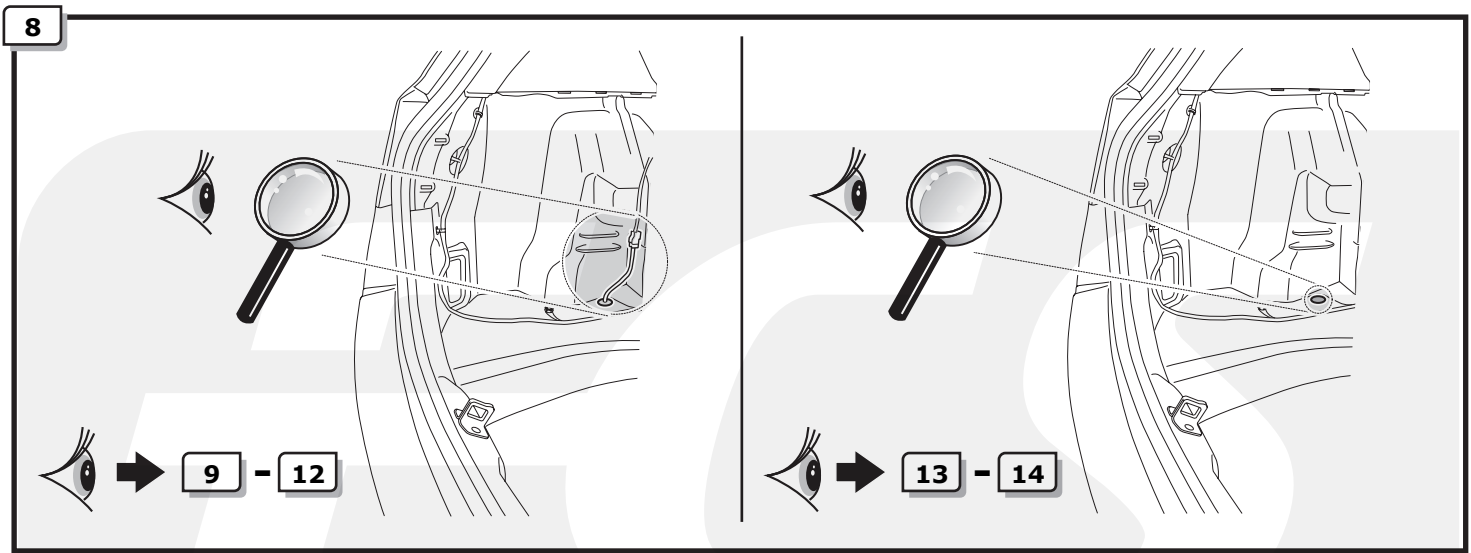

12

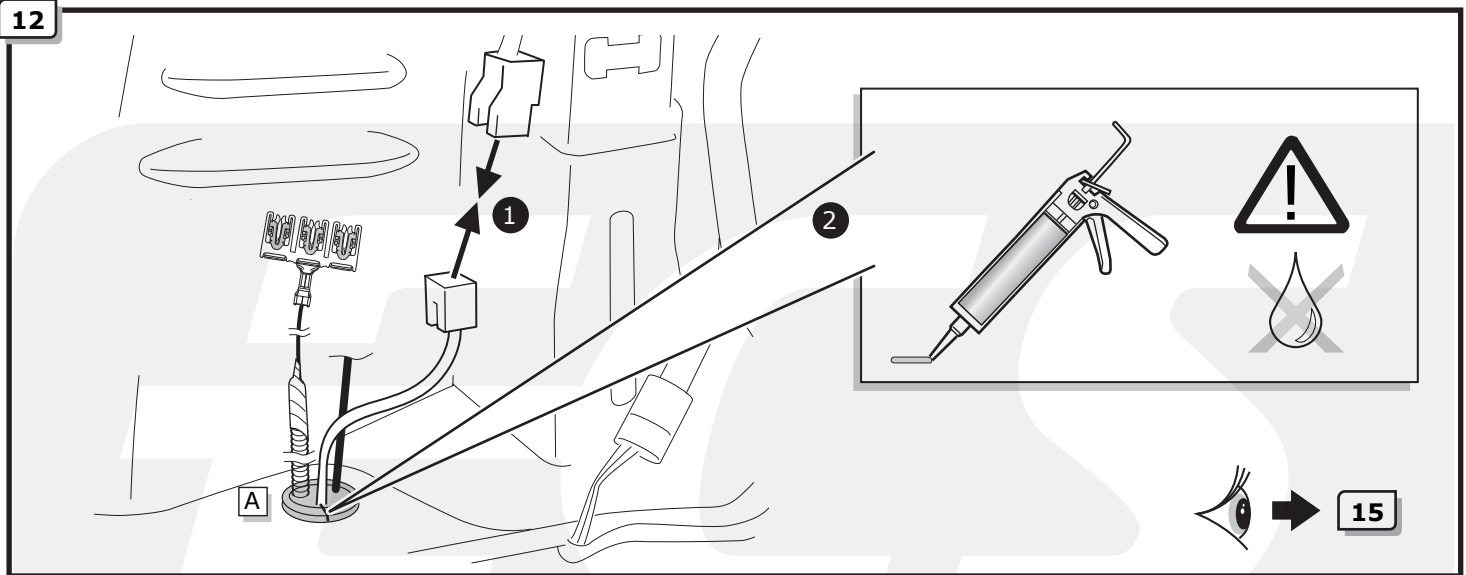

13

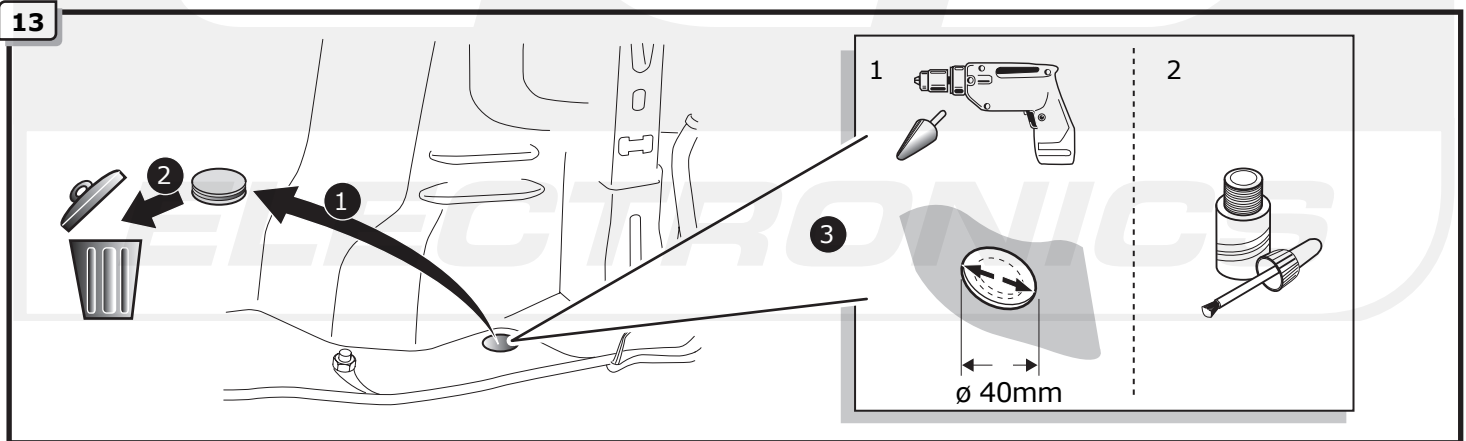

14

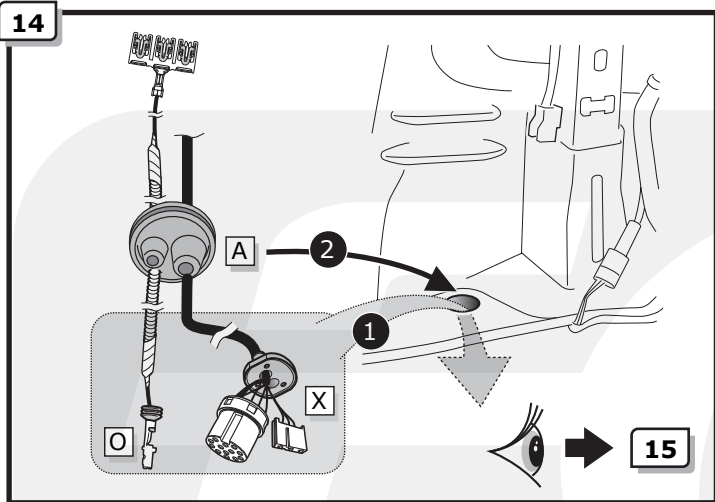

15

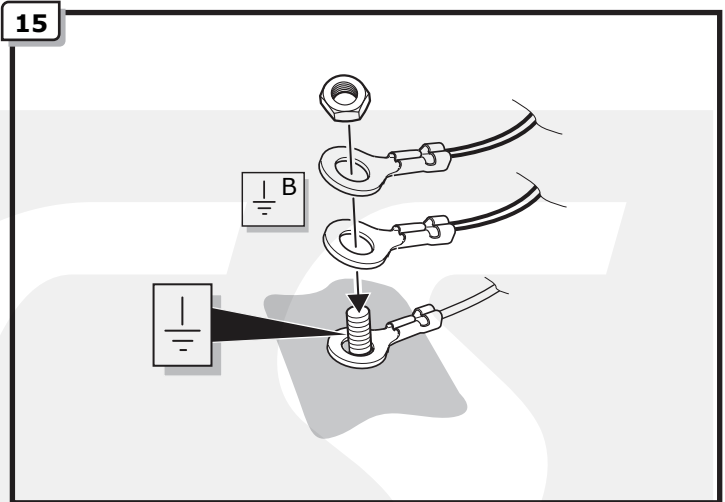

16

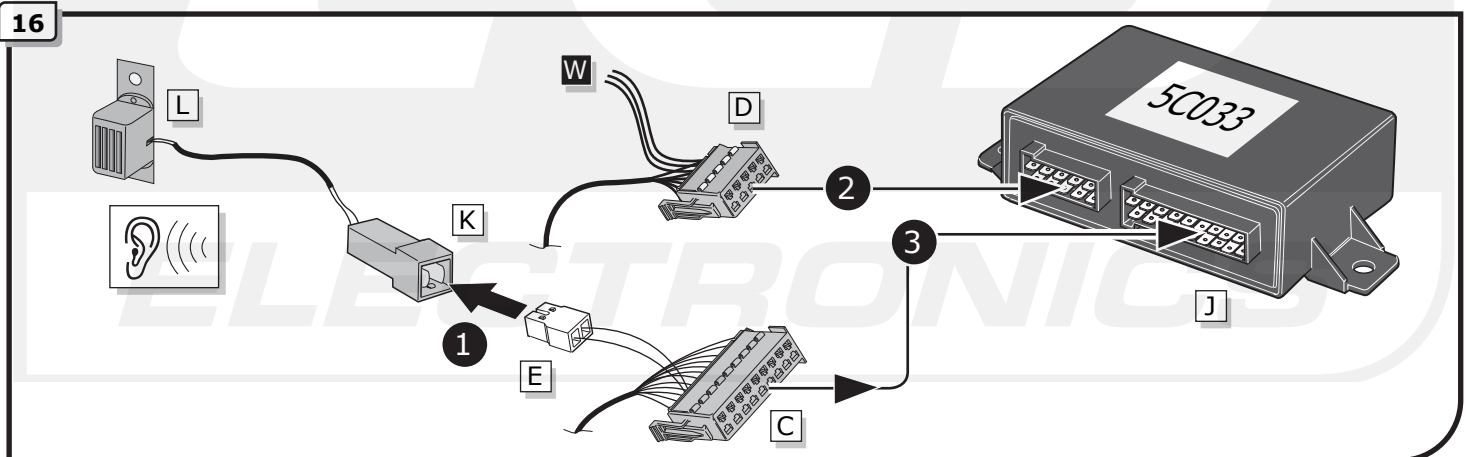

17

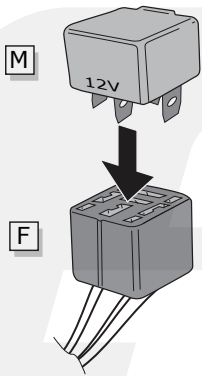

18

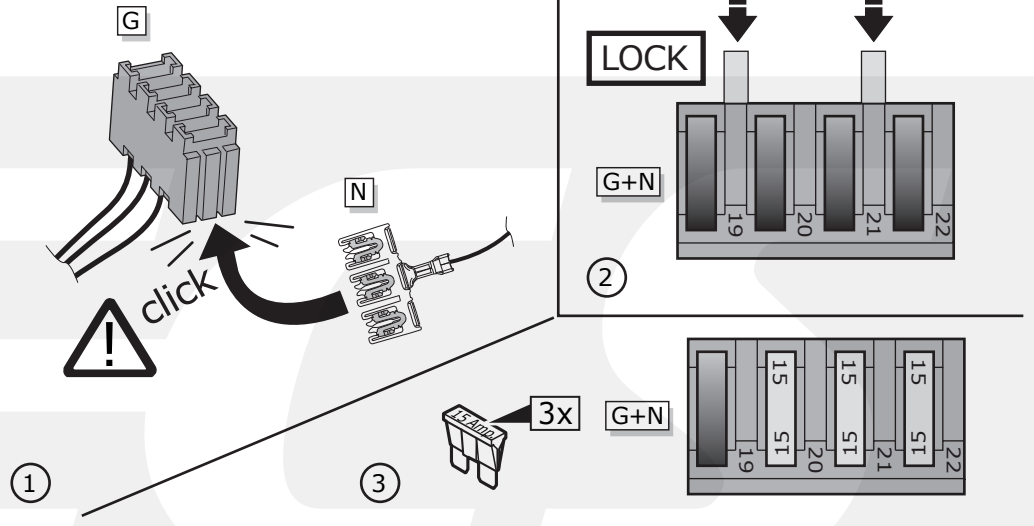

19

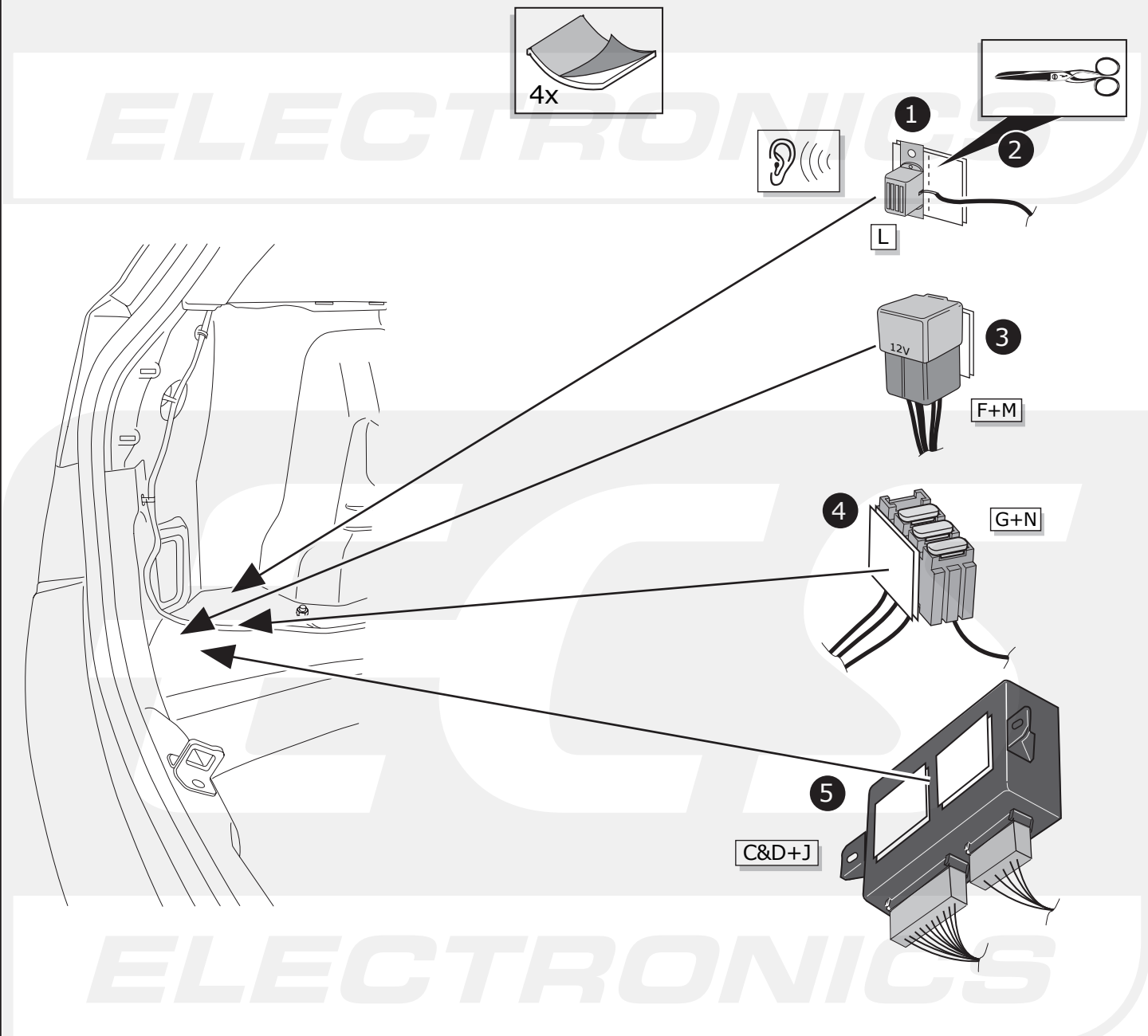

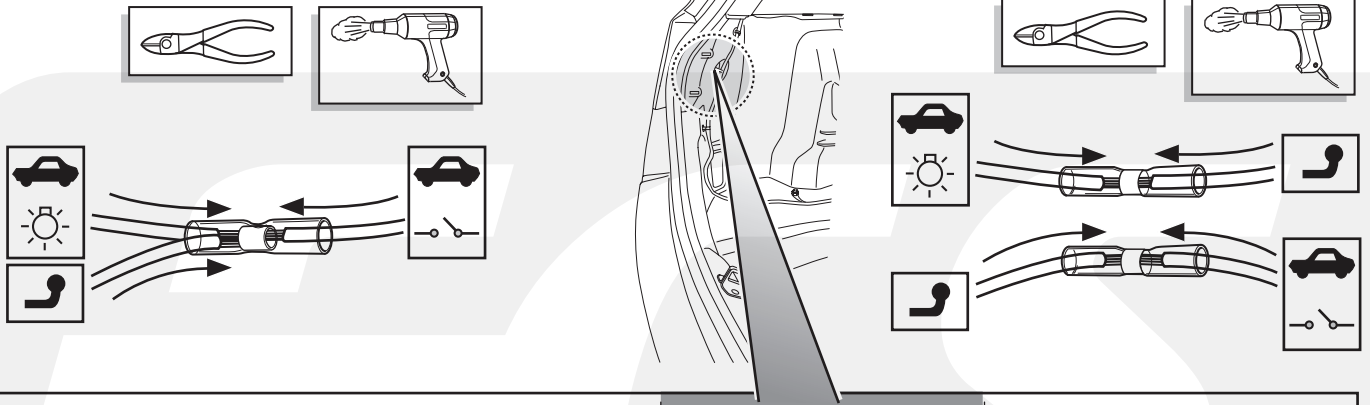

54	L	58-L	15+				
Blau/Rot	Schwarz/Gelb	Violett/Schwarz	Rot	DE	DE	Blau	Grau
Blue/Rouge	Noir/Jaune	Violet/Noir	Rouge	FR	FR	Blue	Gris
Blauw/Rood	Zwart/Geel	Paars/Zwart	Rood	NL	NL	Blauw	Grijs
Blue/Red	Black/Yellow	Purple/Black	Red	GB	GB	Blue	Grey
Azul/Rojo	Negro/Amarillo	Morado/Negro	Rojo	ES	ES	Azul	Gris
Blu/Rosso	Nero/Giallo	Viola/Nero	Rosso	IT	IT	Blu	Grigio
Blå/Röd	Svart/Gul	Lila/Svart	Röd	SE	SE	Blå	Grå
Modro/Červená	Černo/Žlutá	Fialovo/Černá	Červená	CZ	CZ	Modrá	Šedá
Blå/Rød	Sort/Gul	Lilla/Sort	Rød	DK	DK	Blå	Grå
Sininen/Punainen	Musta/Keltainen	Purppura/Musta	Punainen	FI	FI	Sininen	Harmaa
Μπλε/Κόκκινο	Μαύρο/Κίτρινο	Μοβ/Μαύρο	Κόκκινο	GR	GR	Μπλε	Γκρι
Blå/Rød	Svart/Gul	Lilla/Svart	Rød	NO	NO	Blå	Grå
Niebieski/Czerwony	Czarny/Żółty	Purpurowy/Czarny	Czerwony	PL	PL	Niebieski	Szary

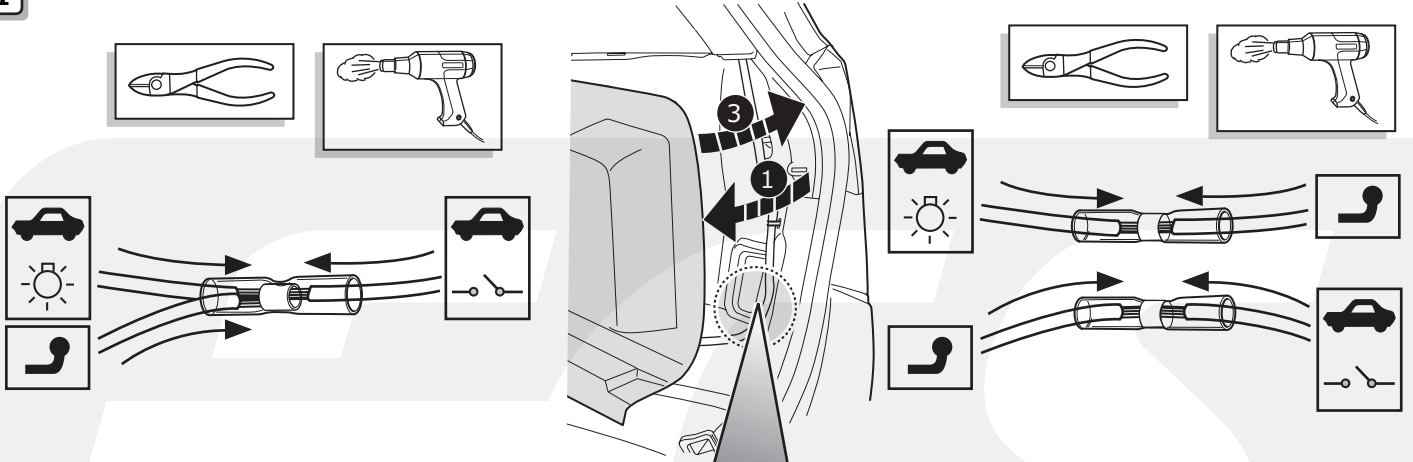

Reverse	R	58-R				
Grün/Rot	Schwarz/Grün	Schwarz/Braun	DE	DE	Blau	Grau
Vert/Rouge	Noir/Vert	Noir/Marron	FR	FR	Blue	Gris
Groen/Rood	Zwart/Groen	Zwart/Bruin	NL	NL	Blauw	Grijs
Green/Red	Black/Green	Black/Brown	GB	GB	Blue	Grey
Verde/Rojo	Negro/Verde	Negro/Marrón	ES	ES	Azul	Gris
Verde/Rosso	Nero/Verde	Nero/Marrone	IT	IT	Blu	Grigio
Grøn/Röd	Svart/Grøn	Svart/Brun	SE	SE	Blå	Grå
Zeleno/Červená	Černo/Zelená	Černo/Hnědá	CZ	CZ	Modrá	Šedá
Grøn/Rød	Sort/Grøn	Sort/Brun	DK	DK	Blå	Grå
Vihreä/Punainen	Musta/Vihreä	Musta/Ruskea	FI	FI	Sininen	Harmaa
Πράσινο/Κόκκινο	Μαύρο/Πράσινο	Μαύρο/Καφέ	GR	GR	Μπλε	Γκρι
Grønn/Rød	Svart/Grønn	Svart/Brun	NO	NO	Blå	Grå
Zielony/Czerwony	Czarny/Zielony	Czarny/Brązowy	PL	PL	Niebieski	Szary

22

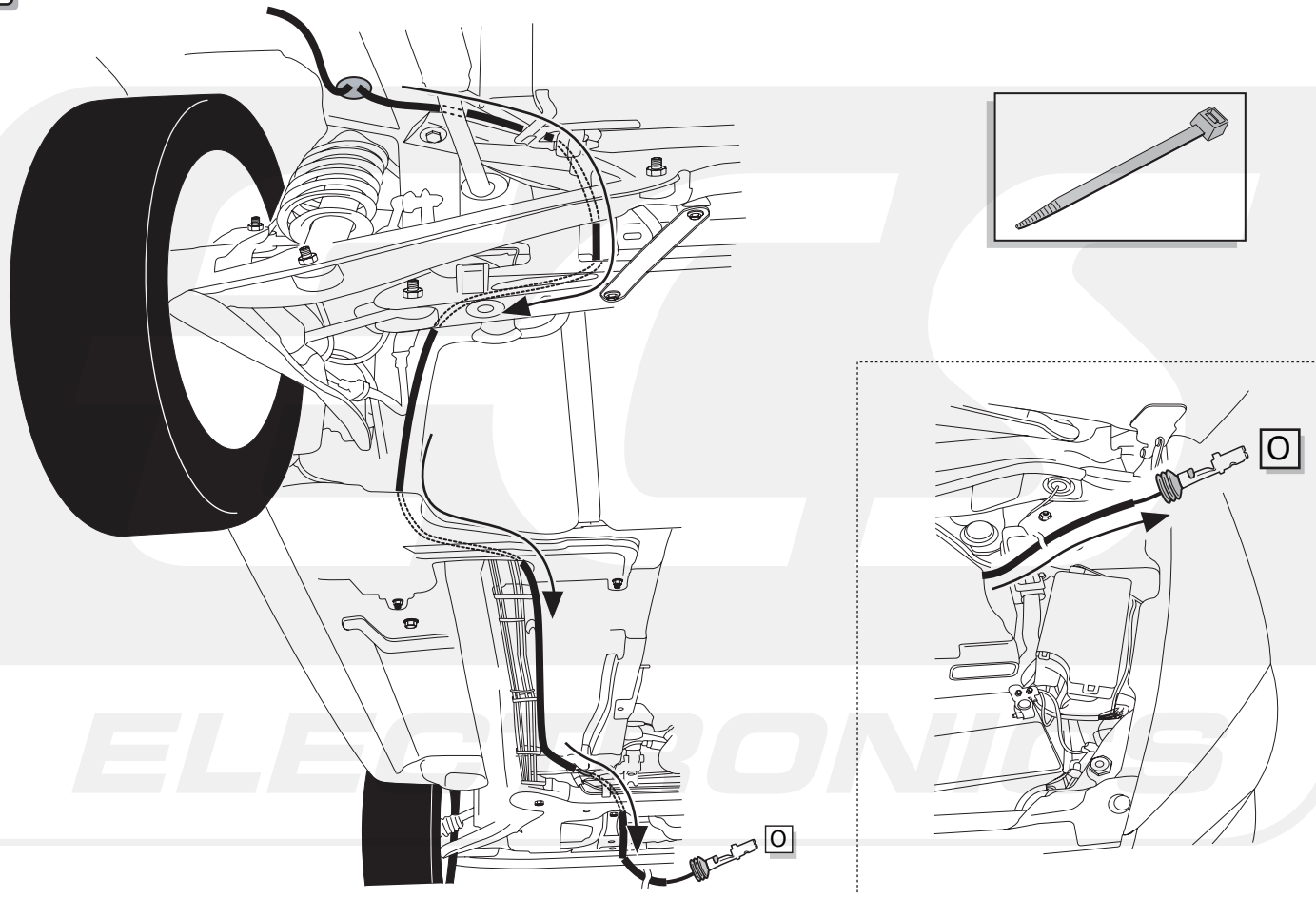

23

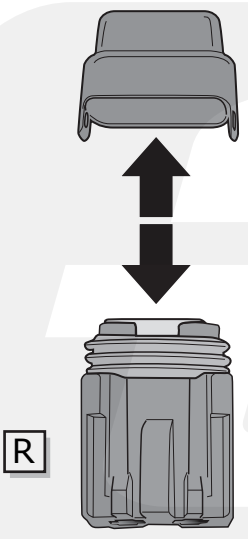

1

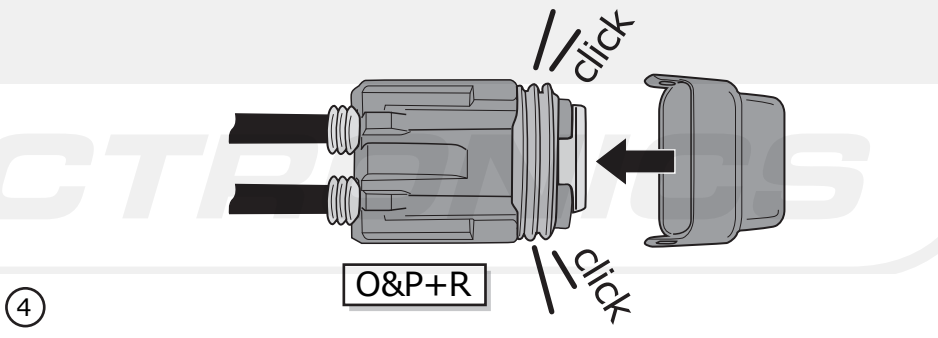
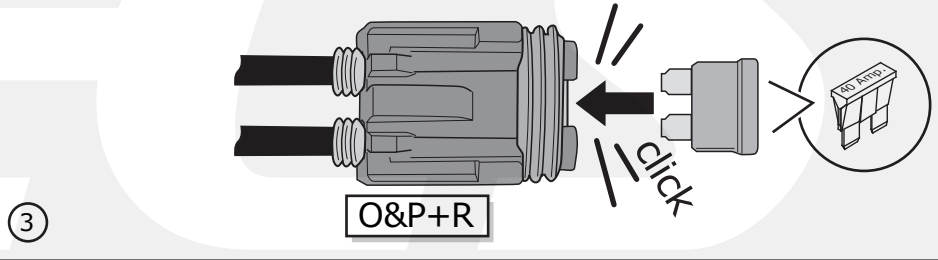
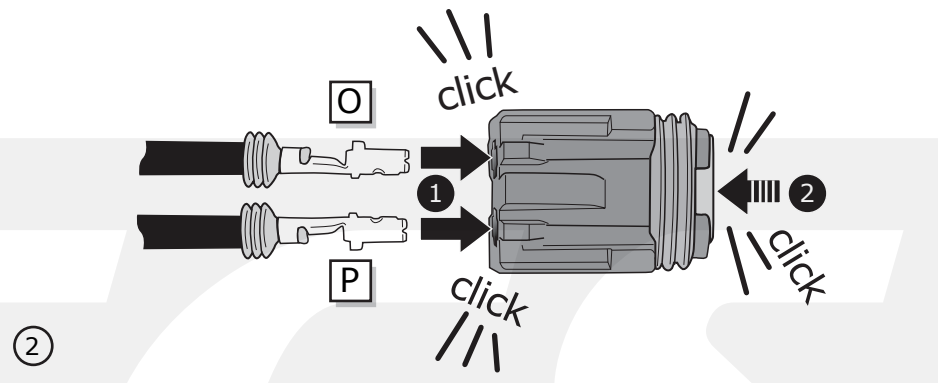

24

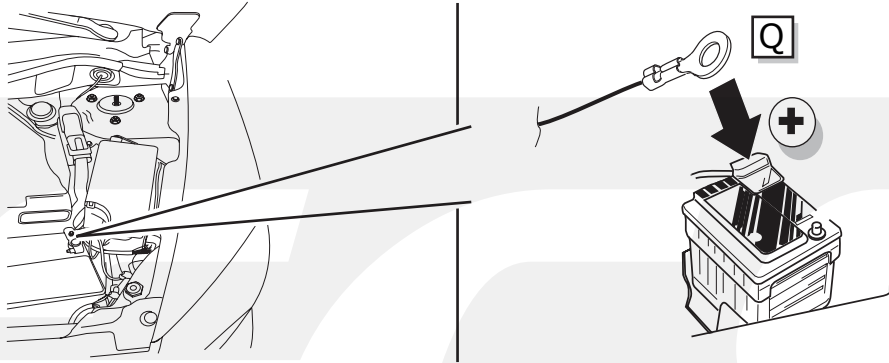

25

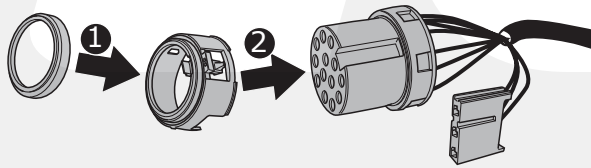

①

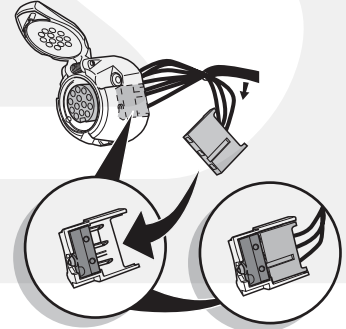

②

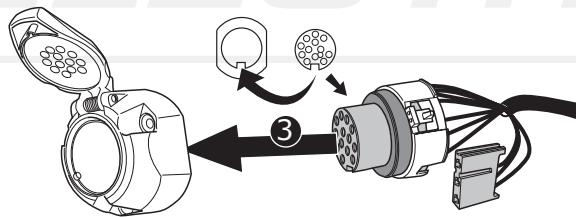

③

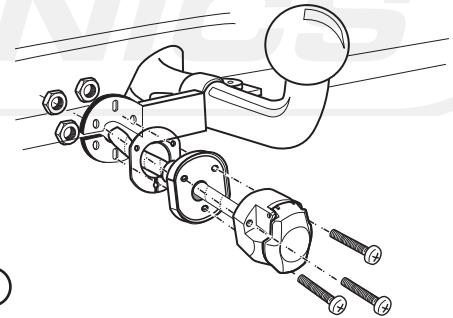

④

26

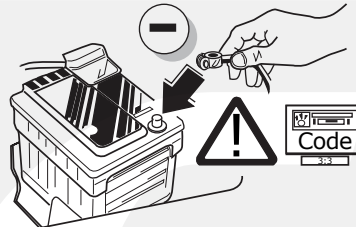

27

DE FUNKTIONEN KONTROLLIEREN MIT EINEM PRÜFGERÄT MIT WIDERSTAND ODER MIT LEUCHTEN MIT DER GENAUEN WATTZAHL!

FR CONTRÔLER LES FONCTIONS AVEC UNE BOÎTE DE TEST AVEC DE LA CHARGE OU DES LAMPES AVEC LA QUANTITÉ CORRECTE DE WATT!

NL CONTROLEER FUNCTIES MET EEN TESTER MET BELASTING OF LAMPEN MET DE JUISTE WATTAGE!

GB TEST ALL CIRCUIT FUNCTIONS WITH A TESTBOX WITH THE CORRECT POWER LOAD FOR EACH UNIT. A TESTBOX ON WHICH ONLY LEDs ARE USED CAN NOT BE USED IN THIS CASE

ES ¡CONTROLAR FUNCIONES CON UN TESTER CON CARGA O LUCES CON EL CORRECTO WATTAJE!

IT CONTROLLA FUNZIONI CON UN TESTER CON CARICO O LAMPADIE DEL GIUSTO WATT-TAGGIO!

SE KONTROLLERA FUNKTIONERNA MED EN TESTARE MED BELASTNING ELLER LAMPOR MED RÄTT WATT-VÄRDE!

CZ OVĚŘTE FUNKCE POMOČÍ TESTOVACÍHO BOXU NEBO SVĚTEL S PŘÍSLUŠNÝM VÝKONEM!

DK CHECK FUNKTIONERNE MED EN TESTBOKS, MED BELASTNING ELLER MED LYGTER MED DET KORREKTE ANTAL WATT!

FI TARKISTA TOIMINNOT KÄYTTÄMÄLLÄ TESTILAITE, JOSSA ON OIKEATEHOINEN KUORMITUS TAI OIKEATEHOISET LAMPUT!

GR ΕΛΕΓΞΤΕ ΤΙΣ ΛΕΙΤΟΥΡΓΙΕΣ ΜΕ ΉΝΑ ΚΙΒΩΤΙΟ ΔΟΚΙΜΗΣ ΜΕ ΦΟΡΤΙΟ Ή ΛΑΜΠΗΤΗΡΕΣ ΣΩΣΤΗΣ ΠΟΣΟΤΗΤΑΣ ΒΑΤ!

NO KONTROLER FUNKSJONENE MED EN TESTER MED BELASTNING ELLER LYSPÆRER MED RIKTIG WATTVERDI!

PL SPRAWDŹ FUNKCJE UŻYWAJĄC SKRZYŃKI TESTOWEJ Z OBCIĄŻENIEM LUB PODŁĄCZONYMI ŻARÓWKAMI O ODPOWIEDNIEJ MOCY!

28

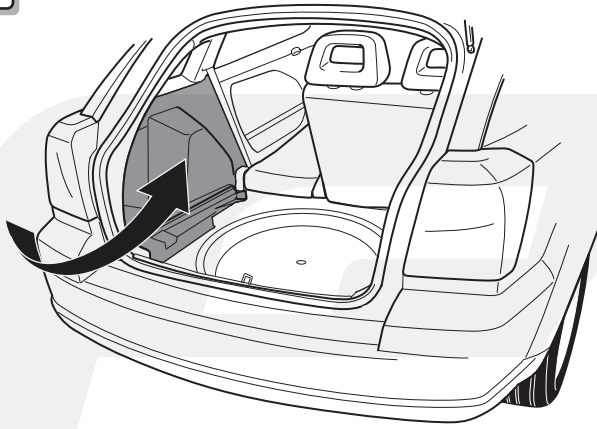

29

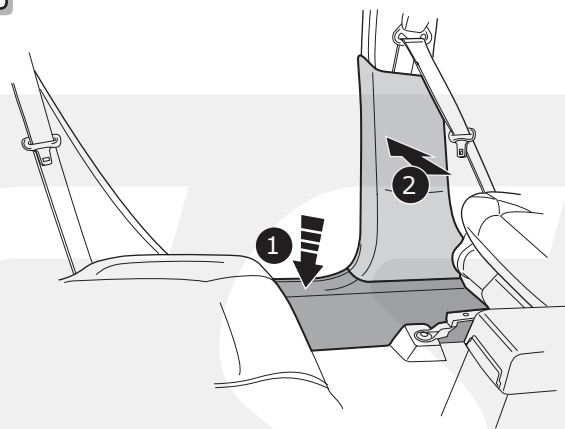

30

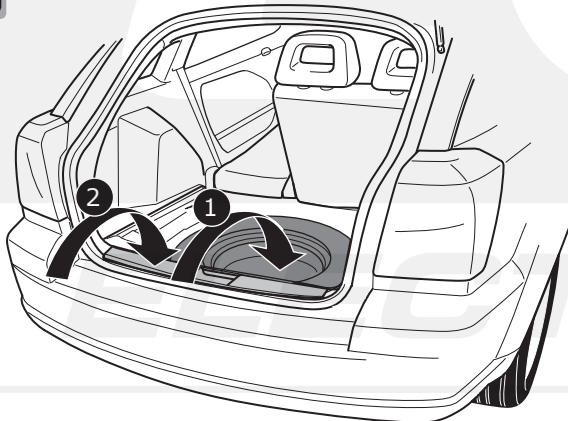

31



32

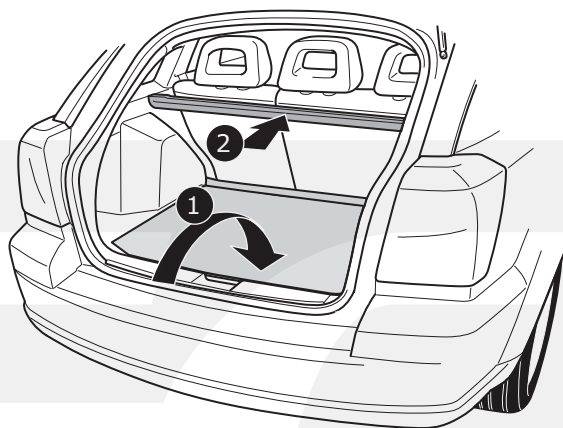

33

- ⓁⒹ Gebrauchsanleitung.
- ⓁⒻⓂ Mode d'emploi.
- ⓁⒶⓂ Gebruikershandleiding.
- ⓁⒼⓁ User guide.
- ⓁⒺⓂ Guía del usuario.
- ⓁⒶⓂ Manuale di istruzioni.
- ⓁⒺⓂ Bruksanvisning.
- ⓁⒸⓂ Uživatelská příručka.
- ⓁⒻⓂ Brugervejledning.
- ⓁⒻⓂ Käyttöohjeet.
- ⓁⒼⓂ Οδηγός χρήστη.
- ⓁⒻⓂ Brukerveiledning.
- ⓁⒶⓂ Instrukcja obsługi.

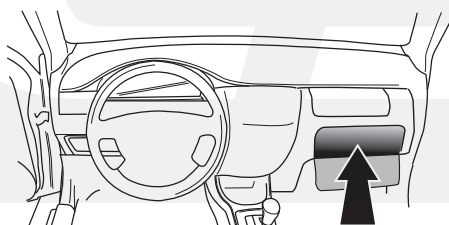

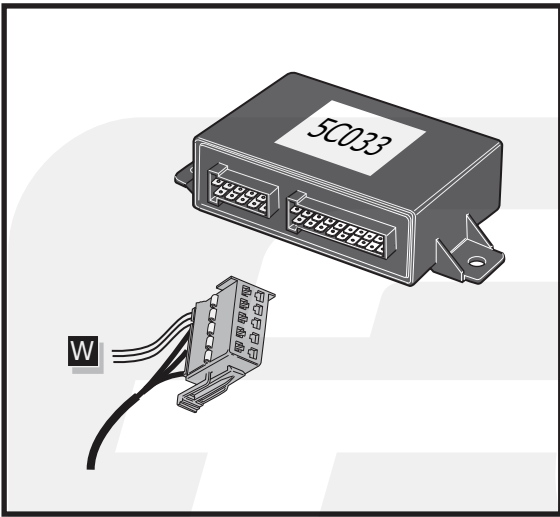

- (DE) Option
- (FR) Option
- (NL) Optie
- (GB) Option
- (ES) Opción
- (IT) Opzione
- (SE) Tillval
- (CZ) Varianta
- (DK) Ekstraudstyr
- (FI) Vaihtoehto
- (GR) Επιλογή
- (NO) Eventuelt
- (PL) Opcja

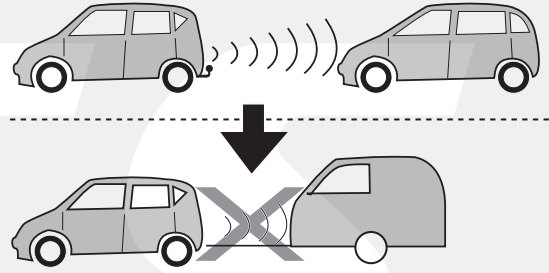

1

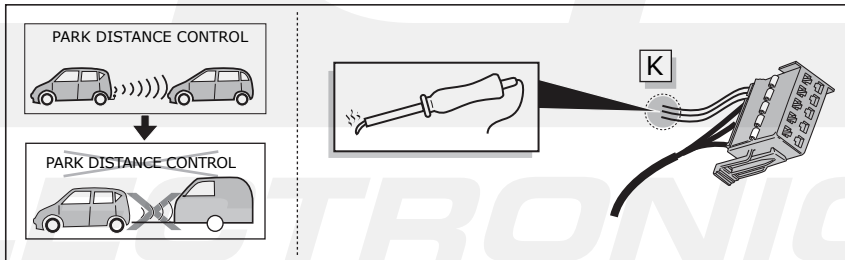

2

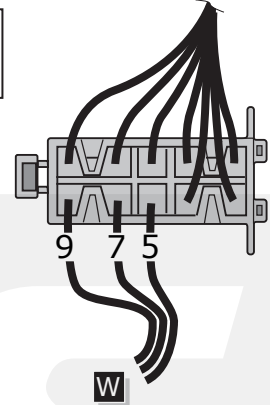
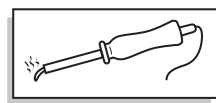
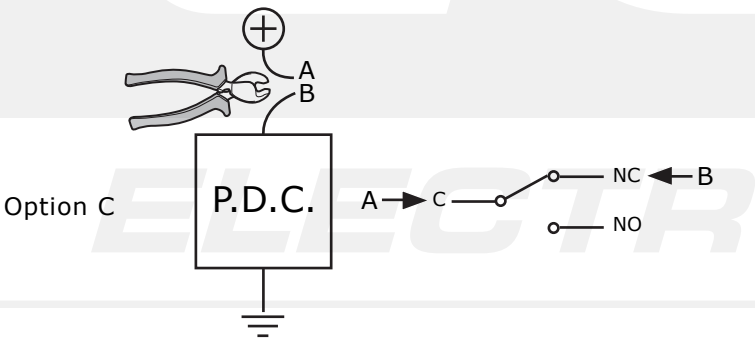
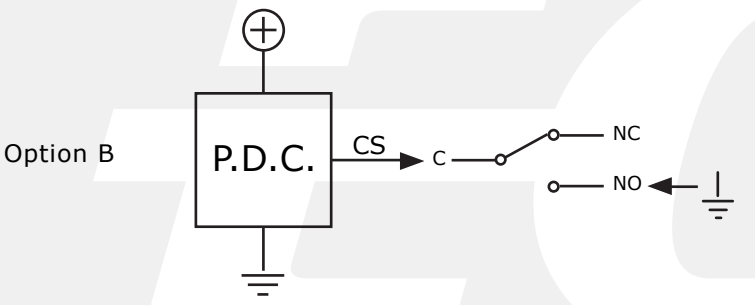
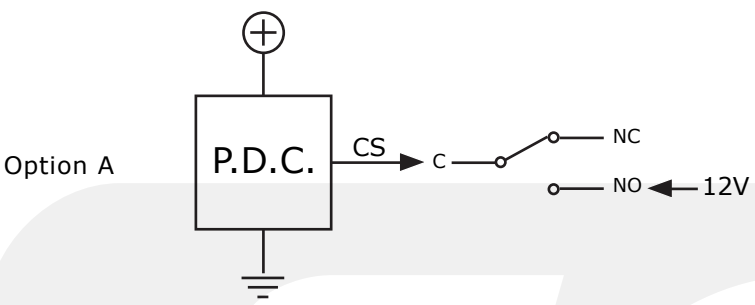

- 9 = C
- (DE) Rot/Schwarz
 - (FR) Rouge/Noir
 - (NL) Rood/Zwart
 - (GB) Red/Black
 - (ES) Rojo/Negro
 - (IT) Rosso/Nero
 - (SE) Röd/Svart
 - (CZ) Červená/Černá
 - (DK) Rød/Sort
 - (FI) Punainen/Musta
 - (GR) Κόκκινο/Μαύρο
 - (NO) Rød/Svart
 - (PL) Czerwony/Czarny

- 7 = NC
- (DE) Blau/Schwarz
 - (FR) Blue/Noir
 - (NL) Blauw/Zwart
 - (GB) Blue/Black
 - (ES) Azul/Negro
 - (IT) Blu/Nero
 - (SE) Blå/Svart
 - (CZ) Modrá/Černá
 - (DK) Blå/Sort
 - (FI) Sininen/Musta
 - (GR) Μπλε/Μαύρο
 - (NO) Blå/Svart
 - (PL) Niebieski/Czarny

- 5 = NO
- (DE) Blau/Weiß
 - (FR) Blue/Blanc
 - (NL) Blauw/Wit
 - (GB) Blue/White
 - (ES) Azul/Blanco
 - (IT) Blu/Bianco
 - (SE) Blå/Vit
 - (CZ) Modrá/Bílá
 - (DK) Blå/Hvid
 - (FI) Sininen/Valkoinen
 - (GR) Μπλε/Λευκό
 - (NO) Blå/Hvit
 - (PL) Niebieski/Biały

- (DE) Anschluss Steckdose (ES) Conexión de la caja de enchufe (CZ) Objímkový konektor (GR) Υποδοχή σύνδεσης
 (FR) Connection de la prise (IT) Allaccio zoccolo (DK) Stikdåse forbindelse (NO) Tilkobling koblingsboks
 (NL) Contactdoos aansluiting (SE) Anslutning kontaktdosa (FI) Pistorasia liitäntä (PL) Połączenie przez gniazdo

DIN/ISO 11446													
1/L	2	3/31	4/R	5/58-R	6/54	7/58-L	8	9	10				
Pmax	2x21W	21W	21W	52W	3x21W	52W	2x21W	180W/15Amp.	180W/15Amp.	180W/15Amp.	180W/15Amp.	180W/15Amp.	180W/15Amp.
(DE)	Blau	Weiß	Grün	Braun	Rot (1,00mm)	Schwarz	Schwarz/ Rot	Braun/ Weiß	Rot (2,50mm)	Weiß	Weiß	Weiß	Weiß
(FR)	Bleu	Blanc	Vert	Marron	Rouge (1,00mm)	Noir	Noir/ Rouge	Marron/ Blanc	Rouge (2,50mm)	Blanc	Blanc	Blanc	Blanc
(NL)	Blauw	Wit	Groen	Bruin	Rood (1,00mm)	Zwart	Zwart/ Rood	Bruin/ Wit	Rood (2,50mm)	Wit	Wit	Wit	Wit
(GB)	Blue	White	Green	Brown	Red (1,00mm)	Black	Black/ Red	Brown/ White	Red (2,50mm)	White	White	White	White
(ES)	Azul	Blanco	Verde	Marrón	Rojo (1,00mm)	Negro	Negro/ Rojo	Marrón/ Blanco	Rojo (2,50mm)	Blanco	Blanco	Blanco	Blanco
(IT)	Blu	Bianco	Verde	Marrone	Rosso (1,00mm)	Nero	Nero/ Rosso	Marrone/ Bianco	Rosso (2,50mm)	Bianco	Bianco	Bianco	Bianco
(SE)	Blå	Vit	Grön	Brun	Röd (1,00mm)	Svart	Svart/ Röd	Brun/ Vit	Röd (2,50mm)	Vit	Vit	Vit	Vit
(CZ)	Modrá	Bílá	Zelená	Hnědá	Červená (1,00mm)	Černá	Černá/ Červená	Hnědá/ Bílá	Červená (2,50mm)	Bílá	Bílá	Bílá	Bílá
(DK)	Blå	Hvid	Grøn	Brun	Rød (1,00mm)	Sort	Sort/ Rød	Brun/ Hvid	Rød (2,50mm)	Hvid	Hvid	Hvid	Hvid
(FI)	Sininen	Valkoinen	Vihreä	Ruskea	Punainen (1,00mm)	Musta	Musta/ Punainen	Ruskea/ Valkoinen	Punainen (2,50mm)	Valkoinen	Valkoinen	Valkoinen	Valkoinen
(GR)	Μπλε	Λευκό	Πράσινο	Καφέ	Κόκκινο (1,00mm)	Μαύο	Μαύο/ Κόκκινο	Καφέ/ Λευκό	Κόκκινο (2,50mm)	Λευκό	Λευκό	Λευκό	Λευκό
(NO)	Blå	Hvit	Grønn	Brun	Rød (1,00mm)	Svart	Svart/ Rød	Brun/ Hvit	Rød (2,50mm)	Hvit	Hvit	Hvit	Hvit
(PL)	Niebieski	Biały	Zielony	Brazowy	Czerwon (1,00mm)	Czarny	Czarny/ Czerwony	Brazowy/ Biały	Czerwony (2,50mm)	Biały	Biały	Biały	Biały