

READ AND SAVE THESE INSTRUCTIONS

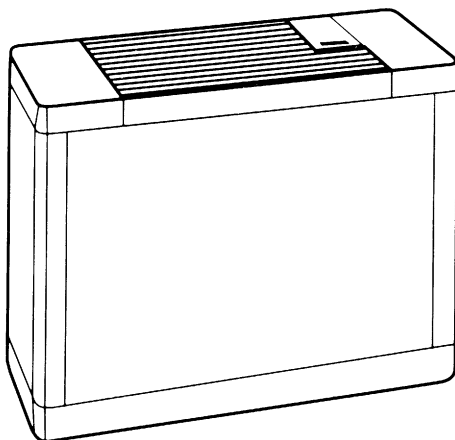

**Evaporative
Humidifier**

OWNERS CARE & USE MANUAL



Models:

- 4D7 800 White, Variable-Speed Digital with Air Care® Filter
- 497 800 White, Variable-Speed with Air Care® Filter
- 497 300 Light Oak, Variable-Speed with Air Care® Filter
- 4D6 800 White, Variable-Speed Digital
- 496 800 White, Variable-Speed
- 447 401 Mahogany Burl, Four-Speed with Air Care® Filter
- 447 301 Mahogany, Four-Speed with Air Care® Filter
- 427 300 Oak Burl, Two-Speed with Air Care® Filter



SAVE THE ENVIRONMENT
RECYCLE APPROPRIATE MATERIALS

Patents: 5,037,583; 5,110,511; 5,133,904
Other Patents Pending

French and Spanish
instructions included.

Se incluyen instrucciones
en Español y Francés.

Directives en français et
en espagnol compris.

Important Safeguards

READ BEFORE USING YOUR HUMIDIFIER

- 1) This appliance has a polarized plug (one blade is wider than the other). To reduce the risk of electric shock, this plug is intended to fit into a polarized 120-volt AC, 15-amp outlet, only one way. If the plug does not fit fully in the outlet, reverse the plug. If it still does not fit, contact a qualified electrician. Do not attempt to defeat this safety feature. If an extension cord must be used, it should also accept the wide blade plug and meet this electrical rating.
- 2) Do not place the cord under rugs, in traffic areas, or near heat sources.
- 3) Do not use the humidifier if the cord is damaged.
- 4) Always unplug the power cord before cleaning, servicing, or when the unit is not in use.**
- 5) Do not place the humidifier near loose drapes, combustible materials, or heat-producing objects.
- 6) This humidifier is UL approved with Bemis by Essick Air brand evaporative wicks in place. To maintain your UL rating, see your service center for all repairs. Use only Bemis by Essick Air brand replacement wicks and chemicals. To order parts, wicks, and chemicals call 1-800-547-3888.
- 7) Regular cleaning is recommended. Refer to the CARE & MAINTENANCE section in this manual.
- 8) It is very important that cleaning solutions and other liquids, such as bleach, which may be used to clean the cabinet are **not sprayed or applied to the power pak/chassis assembly**. These cleaning solutions can cause a serious electrical malfunction of the humidifier.

Introduction

Your Bemis by Essick Air evaporative humidifier adds invisible moisture to your home by moving dry inlet air through a saturated wick. As air moves through the wick, the water evaporates into the air, leaving behind any white dust, minerals or dissolved and suspended solids. Because the water is evaporated, there is no messy mist or spray, and no white dust, just clean and invisible moist air.

As the wick traps accumulated minerals from the water, its ability to absorb and evaporate water decreases. We recommend changing the wick at least once a year, preferably disposing of the used wick at the end of the humidifying season and starting with a new one at the beginning of the next humidifying season. In hard water areas, more frequent replacement may be necessary to maintain your humidifier's efficiency.

NOTICE: We recommend using Bemis by Essick Air Bacteria Treatment, whenever you refill the water bottles to eliminate bacteria growth. Follow the directions to determine the proper amount to be added to the 2.75 gallon water bottles.

The evaporative wick does not require the use of chelating agent type water treatments that are intended for use in Rotobelt or Water Wheel type humidifiers.

Your humidifier is equipped with two water bottles. When both bottles have emptied, the humidifier fan will automatically shut off and the "Refill Water Bottles" message will light. The unit will start again automatically when the water bottles are refilled. The right bottle will empty first. If it does not do so, the humidifier may not be level.

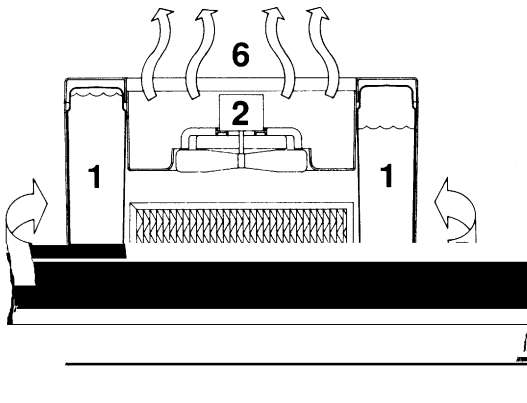

Dry air is drawn into the humidifier through the back and moisturized as it passes through the evaporative wick.

It is then fanned out into the room.

1. Water bottles
2. Chassis/Power pak (motor and fan assembly)
3. Evaporative wick
4. Water channel/tray
5. Dry room air intake
6. Moist air output

Locate your humidifier on an inside wall, near an electrical outlet. The humidifier should be at least 4" away from the wall for best results. Do not position the unit directly in front of a hot air duct or radiator.

Assembly and Operation

- 1) Unpack humidifier from carton.
- 2) Remove all packaging materials. Check to see that you have all of the following items before discarding packaging:

Fill hose

Cord Set

Evaporative wick

Two end covers

Two water bottles with caps

Caster kit

Air Care filter if unit is an Air Care model

NOTICE: The wick and Air Care filter are packaged to prevent breakage in shipping. They must be removed from the unit and correctly installed according to these instructions prior to operation to prevent damage to the unit.

CASTERS

- 3) Remove the water bottles, chassis and evaporative wick from the base of the humidifier. Turn the base of the empty humidifier upside down. Insert the caster stem into the large caster holes in the four corners of the humidifier bottom. The casters should fit snugly and be inserted as far as possible. Do not force. When all four casters are in place, turn the unit right side up.

EVAPORATIVE WICK

- 4) The wick has a mounting rib on the top edge which hooks over a rib at the inside back of the cabinet. This allows the wick to hang in the water channel (see illustration). Hang evaporative wick into cabinet as shown.

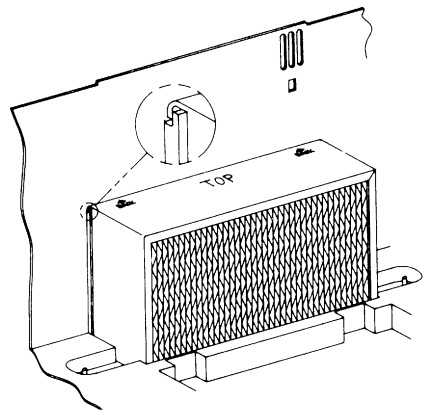

AIR CLEANING FILTER (Models 4D7 800, 497 800, 497 300, 447 401, 447 301 & 427 300)

- 5) The Air Care filter has four tangs that engage into four keyhole slots that mount the Air Care filter onto the outside of the back of the cabinet.

CHASSIS/POWER PAK

- 6) Place the chassis/power pak unit into the cabinet ensuring that chassis/power pak seats correctly onto the front and back edges of the cabinet.

BOTTLES

- 7) Fill the bottles with **cool**, fresh, preferably **unsoftened water**. If you have only softened water available in your home, you may use it, but you will notice a buildup of minerals on the wick much sooner. The bottles hold 2.75 gallons each. When filling the bottles, be careful not to pressurize them by over filling. Bottle damage can result from this. To reduce carrying weight, the bottle may be partially filled and unit will still operate properly. A fill hose is provided with your humidifier which will fit most faucets.

- 8) **We recommend using Bemis by Essick Air Bacteria treatment whenever you refill the water bottles to eliminate bacterial growth.** Add bacteriostat according to the instructions on the bottle and then tighten the valve caps on your water bottles.
- 9) Place water bottles into the humidifier with the **valve cap end down** and to the back of the humidifier so that the valve cap enters the water channel, aligning with the "post" in the cabinet.
- 10) Place the end covers over the water bottles.
- 11) Plug cordset into interlock receptacle on back of unit.
- 12) Plug cordset into wall receptacle. Humidifier is now ready for use.

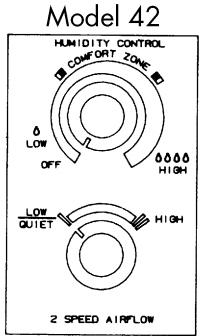

CONTROLS (Models 497 800, 497 300, 496 800, 447 401, 447 301, 427 300)

FAN SPEED

- 13) Open control panel door by lifting with your finger under the finger tab. Depending on which model you have, you will have a choice of two, three, four or variable fan speeds allowing you to use a low setting for the most quiet operation or a high setting for maximum output.

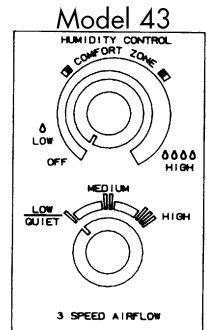

HUMIDITY SETTING

- 14) All models have an automatic humidistat. The humidistat will turn the humidifier on when the relative humidity in your home is below the humidistat setting and will turn the humidifier off when the relative humidity reaches the humidistat setting. For initial operation set the humidistat in the "comfort zone" and adjust up or down from there to achieve the desired humidity level. Turning the variable-speed humidistat all the way counterclockwise will turn the unit off regardless of the relative humidity. This must be turned on again before the unit will work.

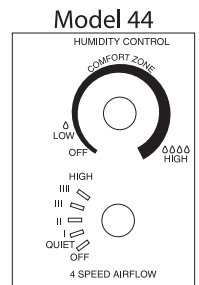

REFILL LIGHTS

- 15) The "Refill Bottles" indicator will light, and the motor will turn off when the bottles are empty. The right bottle will empty first, then the left bottle. If the "Refill Light" comes on, and the right bottle has not emptied, raise the right side of the unit until it is level.

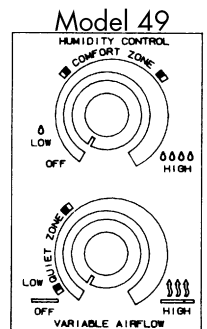

CONTROLS (Model 4D7 800, 4D6 800 Digital Humidistat)

16) Models 4D6 800 and 4D7 800 are equipped with a multi-speed fan control switch. Use the lower settings for quiet operation, and the higher settings for maximum output. These models have a digital humidistat with LCD display. The room's Relative Humidity (% RH) is displayed at the top and the desired humidity level is displayed at the bottom. The desired humidity level can be manually adjusted between 30 and 90%, using the "Set Humidity" button. 45% RH is the suggested initial setting.



- 17) The automatic humidistat will turn the humidifier ON when the relative humidity in your home is below the humidistat setting and will turn the humidifier OFF when the relative humidity in the room exceeds the humidistat setting by 6% R.H. This will reduce rapid cycling. When the humidifier is running, you will feel cool, invisible, humid air exiting from the outlet grill.
- 18) When first plugged in, the display will show the current % Room Humidity and will default to 45% Set Humidity. If there is no water in the cabinet, the red "Refill" indicators will be lit and the fan motor will not run. Fill both water bottles, following the "Filling Water Bottles" instructions. When the bottles have been filled, the LCD display will initiate with a segment display test, the Room and Set humidity % will be displayed, and the fan speed will be shown as OFF.

FAN SPEED

19) The fan speed can be set to the desired airflow level by pressing the "Set Speed", (left), button. The Green power indicator will be lit. To increase fan speed, repeatedly press the "Set Speed" button. A bar segment indicator at the left side of the display will indicate increasing fan speed. After the HIGH fan speed has been reached, the next press of the button will return back to the LOWEST fan speed. To turn the humidifier OFF, press AND HOLD the "Set Speed" button down for two seconds.

HUMIDITY SETTING

20) If the room humidity is lower than the Set Humidity, the fan motor will start and run until the room humidity exceeds the Set Humidity by +6% R.H. If higher than the Set Humidity, the fan motor will not start. The desired humidity level can be changed with the "Set Humidity", (right), button. Press the button once, and the display will flash. Repeatedly pressing the button will increase the Set Humidity in steps of 5% RH. When the desired humidity level is reached, (between 30 – 90 % RH), release the button. If the button is released and then held down while flashing, the display will auto-advance through the range. Release the button to exit the auto-advance mode.

BOTTLE REFILL SYSTEM

- 21) When one bottle empties, one red refill indicator light will light, and the fan will continue to run. When the water bottles are both empty, the two red refill indicator lights will be lit and the fan motor will stop.
- 22) After the "Set Humidity" button has been inactive for three seconds, the control will exit the Set Mode with the last programmed number remaining on the display.

NOTICE: Under certain conditions, cold objects in the room, such as windows and outside walls, may cause moisture to condense. Severe condensation on window sills and walls may result in water damage. When these conditions exist, a lower humidistat setting is recommended.

Air Care® Filter

**MODELS 4D7 800, 497 800, 497 300, 447 401, 447 301
AND 427 300**

Air Care® models feature a two-stage air filter which attaches to the back of the humidifier. The Air Care® filters the air as it humidifies.

The first stage of the air filter is a high-efficiency, electrostatically-charged filter media which traps dust, pollen and airborne pollutants. The second stage of the Air Care® filter is an activated carbon media which absorbs odors from cooking, pets or tobacco smoke.

We recommend replacing the Air Care® filter at least once a year, more often if necessary. When the white filter media is coated with a layer of dust and dirt, it is time to replace the Air Care® filter. The certified water output of your humidifier will be reduced when using the Air Care® filter

Air Care® filters are optional and are not required for normal operation of the humidifier.

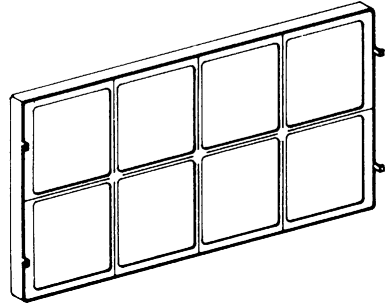

Care and Maintenance

IMPORTANT: We recommend cleaning your humidifier every two weeks.

Follow instructions.

Humidifiers provide comfort by adding moisture to dry, heated indoor air. To get the most benefit from the humidifier and avoid product misuse, follow all instructions carefully, specifically the operation, care and maintenance guidelines. Please note this is an electrical appliance and requires careful attention when in use.

In addition, if you do not follow the recommended care and maintenance guidelines, microorganisms may be able to grow in the water within the humidifier's reservoir.

⚠ CAUTION: Disconnect power before cleaning or servicing unit.

⚠ WARNING: It is very important that cleaning solutions, such as bleach, bacteria treatment, or descaler which could be used to clean the cabinet are not sprayed or applied to the chassis/power pak assembly. Additionally, do not immerse the power pak in water or any other solution. These solutions can cause a serious electrical malfunction of the humidifier.

- 1) Turn unit off by turning humidistat completely counterclockwise. For digital unit, hold speed button down for two seconds.
- 2) Unplug electrical cord from wall outlet.
- 3) Unplug interlock plug from chassis/power pak receptacle.
- 4) Lift off end covers and remove both water bottles.

NOTICE: Water bottles must be removed before chassis/power pak to prevent possible switch lever damage.

- 5) Lift chassis/power pak unit from cabinet.

REMOVING SCALE

- 6) Carefully lift wick from cabinet, allowing any water to drain from it into water channel. Place in sink or tray to finish draining.
- 7) Remove any remaining water in channel with a sponge. Fill water channel with one 8 oz. cup of undiluted white vinegar.

Let solution stay 20 minutes. Remove with a sponge. Clean all interior surfaces with soft brush. Dampen soft cloth with undiluted white vinegar and wipe out water channel to remove scale.

- 8) Rinse water channel thoroughly with fresh water to remove scale and cleaning solution before disinfecting.

DISINFECTING RESERVOIR

- 9) Fill water channel with mixture of one teaspoon chlorine bleach in one gallon water. Let solution stay 20 minutes, swishing every few minutes. Make sure the cleaning solution does not come in contact with the chassis/power pak. Do not attempt to pour liquid directly through the grill into the humidifier cabinet.

- 10) Empty water channel after 20 minutes. Rinse with water until bleach smell is gone. Dry with clean cloth or paper towel.
- 11) Clean all surfaces of the chassis/power pak with a soft dry cloth. **⚠ WARNING**
DO NOT USE LIQUID CLEANING SOLUTIONS, INCLUDING WATER, TO CLEAN THE CHASSIS/ POWER PAK. AN ELECTRIC SHOCK MAY RESULT OR THE HUMIDIFIER MAY BE DAMAGED.
- 12) Remove water bottle cap and empty remaining water into a drain. Pour a mixture of one pint of water and two tablespoons of household bleach into each bottle. Replace caps and shake bottles thoroughly. Remove caps, drain bottle into sink, rinse well with fresh water.
- 13) Replace evaporative wick into water channel, allowing it to hang from the rib on the inside back wall of the cabinet.
- 14) Replace chassis/power pak unit into cabinet, ensuring that the chassis seats correctly on the back edge of the cabinet.

- 15) Replace water bottles into cabinet.
- 16) Replace end covers onto cabinet.
- 17) Plug cord set into interlock receptacle at back of unit. Plug cord set into wall outlet.
- 18) Reset humidistat to desired setting and adjust fan speed.

EVAPORATIVE WICKS

- 19) We recommend replacing the wick at least once a season, more often in hard water areas. When the wick appears excessively clogged with mineral deposits, discard it and restore your humidifier's efficiency with a new wick. Bemis by Essick Air number 1041 fits all console humidifiers.
Call 1-800-547-3888 to order.
Only Bemis by Essick Air evaporative wicks guarantee the certified output of your humidifier.
Use of a wick other than a Bemis by Essick Air will void your warranty as well as the certification of output and may reduce the efficiency and output of your humidifier.

Summer Storage

- 1) Clean unit as outlined in Care & Maintenance section.
- 2) Discard used wick. Install a new Bemis by Essick Air wick at the beginning of the next season. Only Bemis by Essick Air wicks guarantee the rated output of your humidifier.
- 3) Allow humidifier to dry thoroughly before storage. Do not store with water inside unit.

Troubleshooting

ALL MODELS:

- 1) Unit does not operate at any speed setting:
 - Polarized cord must be fully inserted in wall outlet.
 - Check refill switch operation. There are two switches on each side of the Power Pack. Unplug the humidifier, remove the water bottles and manually trip each switch spring lever. You should hear the switch "click". If not, service may be required.
 - Refill with water if necessary.
 - The motor contains a temperature-sensing fuse. If the motor becomes overheated, the fuse may trip. Unplug the unit and contact the nearest authorized service station. **DO NOT ATTEMPT** electrical repairs yourself.
- 2) Not enough humidity:
 - This is an evaporative type humidifier. The humidity output is invisible.
 - Check the condition of the evaporative wick. Replace if clogged or hardened with minerals.
 - Humidistat is not set high enough—increase humidity setting.
- 3) Too much humidity:
 - When condensation becomes heavy on cold surfaces in the room, turn the humidistat setting lower or increase the room temperature.
- 4) Water Leak:
 - Any hole in the water bottle will allow air to enter the bottle and all the water in the bottle to run out. Do not puncture the bottle in an attempt to drain it faster.

5) Odor:

- Bacteria may be present. Clean and disinfect cabinet following CARE AND MAINTENANCE instructions. Use Bemis by Essick Air Bacteria Treatment to help eliminate unpleasant odors. It may be necessary to replace the wick if the odor persists.

6) Right water bottle has water remaining when unit shuts off:

- The unit is designed to empty the right water bottle first, then the left bottle. If the refill light comes on, and the right bottle has not emptied, raise the right side of the unit with spacers until the unit is level.

DIGITAL HUMIDISTAT

MODELS:

7) Rapid cycling humidistat:

- Certain room conditions may result in the humidifier running for short periods of time, turning off, and then restarting in short cycles. Increase the "Set Humidity" to the next higher % setting.
- Move the humidifier to a different location in the room.
- Maintain 4 inches clearance to the wall.

8) Fan motor does not start:

- Bottles must be filled.
- Fan speed must be set, (not OFF), green power light must be ON.
- Set Humidity % must be higher than Room Humidity %.

9) The electronic module is not consumer serviceable – contact an authorized service center for assistance.

Accessories

EVAPORATIVE WICK

Model 1041. Replaceable evaporative wick continuously draws up moisture as it filters out mineral deposits and reduces scale build-up in the unit. Only Bemis by Essick Air wicks are UL and AHAM certified to provide the rated performance from your Bemis by Essick Air Humidifier.

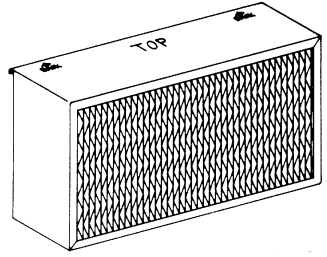

AIR CARE® FILTER

Model 1051. Replaceable two-stage Air Care filter- 3M FILTRETETM removes airborne particles and activated carbon removes odor. This is **not** standard on all units. It can however be added as an accessory to any Bemis by Essick Air Console Humidifier.

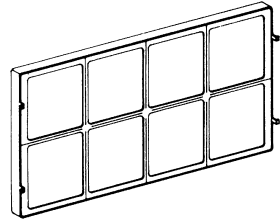

BACTERIA TREATMENT

No.1970-32 oz. Bacteria Treatment. Controls bacteria growth in humidifiers. Helps eliminate unpleasant odors. This solution should not be used to clean the humidifier chassis/power pak. Improper use of this solution can cause a serious electrical malfunction of the humidifier.





**HOME COMFORT DIVISION
ONE-YEAR LIMITED WARRANTY**

The Bemis by Essick Air humidifier warranty covers defects in materials and workmanship for a period of one year from date of retail purchase. This warranty applies only to the original purchaser of the product.

Within the first 12 months from date of purchase, Essick Air will repair or replace, at its discretion, any defective part of the humidifier covered by this warranty.

This warranty gives you specific legal rights, and you may also have other rights which vary from state to state or province to province.

This warranty does not cover damage resulting from misuse or abuse of the humidifier, accidents or alterations to the product, commercial use or damage during shipment. Misuse includes malfunctions caused by negligence in cleaning or parts fouled with mineral deposits due to hard-water conditions. Alterations to the product include the substitution of non-Bemis by Essick Air brand components including, but not limited to, wicks.

If service becomes necessary, take or send the product to any Bemis by Essick Air service center.



Essick Air Products, Inc.
5800 Murray Street
Little Rock, AR 72209
501.562.1094



ACCESSORY ORDER FORM

To keep your humidifier in top working condition, use only Bemis by Essick Air replacement parts. Only Bemis by Essick Air replacement wicks guarantee your humidifier will maintain its original AHAM certified output.

No. 1041
Superwick for 400 & 600 Series
Console & Credenza Humidifiers.
\$15.99

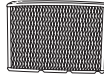
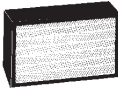

No. 1045
Superwick for H12 Series
Console Humidifiers
\$18.99

No. H4000
Summer Protective
Dust Cover for 400 Series
Console Humidifiers
\$6.99

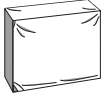

No. 1051
Air Cleaner Filter for 400 & 600 Series
Console & Credenza Tabletop Humidifiers
\$17.99

No. 1043
Superwick for 800 Series
Space Saver Console Humidifiers
\$12.99
• Filter only, frame not included



No. 1970
Bacteria Treatment, 32 oz.
\$5.99

• Helps Eliminate Bacteria & Algae Build-up
• Strongly Recommended for Bemis Humidifiers
& All Other Evaporative Humidifiers

No. 1990
Digital Hygrometer/Comfort Sensor
\$25.99
• Digitally monitors temperature & humidity

Item #	Description	Qty	Unit Price	Amount
1041	Superwick for 400 and 600 Series Console Humidifiers		15.99	
1043	Superwick for 800 Series Space Saver Console Humidifiers		12.99	
1045	Superwick for H12 Series Console Humidifiers		18.99	
1051	Air Cleaner Filter for 400 and 600 Series Console Humidifier		17.99	
1970	Bacteria Treatment, 32 oz.		5.99	
H4000	Summer Protective Cover for 400 Series Console Humidifiers		6.99	
1990	Digital Hygrometer/Comfort Sensor		25.99	

Shipping Schedule	
\$0.00 - 19.99	.. \$4.00
\$20.00 - 49.99	.. \$6.00
\$50.00 - 99.99	.. \$8.00
\$100.00+	... \$10.00

TOTAL MERCHANDISE _____
 CT RESIDENTS ADD 6% TAX _____
 SHIPPING & HANDLING _____
 TOTAL INVOICE AMOUNT _____

Source Code	Revised
BEM 110	05/03/04

Name _____

Address _____

City _____ State _____ Zip Code _____

Phone number _____

Email address _____

Enclosed is my:

Check or Money Order (US Currency) payable to:

BEMIS BY ESSICK AIR

Visa/MasterCard

American Express

Discover

Card #: _____

Signature: _____

Expiration Date: _____

Web Orders: www.bemis-parts-store.com

Telephone Orders: • Call toll free 1-800-547-3888
• \$15.00 minimum telephone orders

Mail Orders: **BEMIS BY ESSICK AIR CONSUMER SERVICES**
20 Constitution Boulevard, South
P.O. Box 884
Shelton, CT 06484-0884

ORDERS ARE SHIPPED WITHIN 24 HOURS.

If outside the continental USA, call for FREIGHT CHARGES.